



Chipsmall Limited consists of a professional team with an average of over 10 year of expertise in the distribution of electronic components. Based in Hongkong, we have already established firm and mutual-benefit business relationships with customers from,Europe,America and south Asia,supplying obsolete and hard-to-find components to meet their specific needs.

With the principle of “Quality Parts,Customers Priority,Honest Operation,and Considerate Service”,our business mainly focus on the distribution of electronic components. Line cards we deal with include Microchip,ALPS,ROHM,Xilinx,Pulse,ON,Everlight and Freescale. Main products comprise IC,Modules,Potentiometer,IC Socket,Relay,Connector.Our parts cover such applications as commercial,industrial, and automotives areas.

We are looking forward to setting up business relationship with you and hope to provide you with the best service and solution. Let us make a better world for our industry!



## Contact us

Tel: +86-755-8981 8866 Fax: +86-755-8427 6832

Email & Skype: info@chipsmall.com Web: www.chipsmall.com

Address: A1208, Overseas Decoration Building, #122 Zhenhua RD., Futian, Shenzhen, China





### Product Description

The RF3021 is a high isolation single-pole double-throw (SPDT) reflective switch designed for general purpose switching applications requiring moderate insertion loss and power handling capability. It features single-bit control with operation as low as 3V. This GaAs pHEMT switch is housed in a compact 3mm, 16-pin, leadless QFN package.

#### Optimum Technology Matching® Applied

- GaAs HBT
- GaAs MESFET
- InGaP HBT
- SiGe BICMOS
- Si BiCMOS
- SiGe HBT
- GaAs pHEMT
- Si CMOS
- Si BJT
- GaN HEMT
- InP HBT
- RF MEMS
- LDMOS

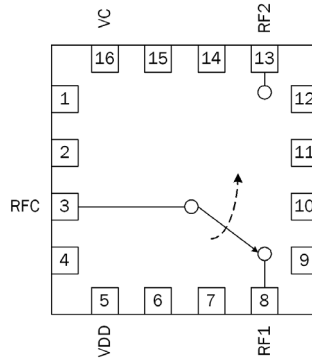

### Features

- 10MHz to 6GHz Operation
- 0.5dB Insertion Loss at 1GHz
- 0.9dB Insertion Loss at 6GHz
- 68dB Isolation at 1GHz
- 40dBm Isolation at 6GHz
- 3V Minimum Voltage
- 50dBm IP3 at 5V

### Applications

- Cellular Handset Applications
- Antenna Tuning Applications
- IEEE802.11b/g WiFi Applications
- Cellular Infrastructure Applications

Parameter	Specification			Unit	Condition
	Min.	Typ.	Max.		
Insertion Loss		0.5		dB	Freq = 10MHz to 1.0GHz
		0.55	0.8	dB	Freq = 1.0GHz to 2.0GHz
		0.6		dB	Freq = 2.0GHz to 3.0GHz
		0.7		dB	Freq = 3.0GHz to 5.0GHz
		0.9		dB	Freq = 5.0GHz to 6.0GHz
Return Loss		18		dB	Freq = 10MHz to 1.0GHz
		18		dB	Freq = 1.0GHz to 3.0GHz
		14		dB	Freq = 3.0GHz to 6.0GHz
Isolation		68		dB	Freq = 0.5GHz to 1.0GHz
	53	58		dB	Freq = 1.0GHz to 2.0GHz
		50		dB	Freq = 2.0GHz to 3.0GHz
		43		dB	Freq = 3.0GHz to 5.0GHz
		40		dB	Freq = 5.0GHz to 6.0GHz
PO.1dB*		30		dBm	Freq = 1.8GHz
IP3*		50		dBm	Freq = 0.5GHz to 2.5GHz, 1MHz spacing, 10 dBm/ tone
I <sub>DD</sub> , Supply Current		200	300	uA	
I <sub>C</sub> , Control Current		20		uA	
T <sub>ON</sub> , T <sub>OFF</sub>		120		nS	50% of V <sub>CTRL</sub> to 10/90% of RF
T <sub>RISE</sub> , T <sub>FALL</sub>		35		nS	10/90% RF

Test Conditions: V<sub>DD</sub> = 5V, 25 °C, 50Ω, with application circuit with 100pF DC blocking capacitors

\*Note: Performance degrades below 50MHz.

## Absolute Maximum Ratings

Parameter	Rating	Unit
Supply Voltage $V_{DD}$	5.5	V
Control Voltage ( $V_C$ )	5.5	V
RF Input Power (on state)	32	dBm
Operating Temp Range ( $T_L$ )	-40 to +85	°C
Storage Temp	-65 to +150	°C
ESD Rating (HBM)	Class 0	
Moisture Sensitivity Level	MSL 2	



Caution! ESD sensitive device.

Exceeding any one or a combination of the Absolute Maximum Rating conditions may cause permanent damage to the device. Extended application of Absolute Maximum Rating conditions to the device may reduce device reliability. Specified typical performance or functional operation of the device under Absolute Maximum Rating conditions is not implied.

The information in this publication is believed to be accurate and reliable. However, no responsibility is assumed by RF Micro Devices, Inc. ("RFMD") for its use, nor for any infringement of patents, or other rights of third parties, resulting from its use. No license is granted by implication or otherwise under any patent or patent rights of RFMD. RFMD reserves the right to change component circuitry, recommended application circuitry and specifications at any time without prior notice.



RFMD Green: RoHS compliant per EU Directive 2002/95/EC, halogen free per IEC 61249-2-21, < 1000ppm each of antimony trioxide in polymeric materials and red phosphorus as a flame retardant, and <2% antimony in solder.

## Evaluation Board Layout

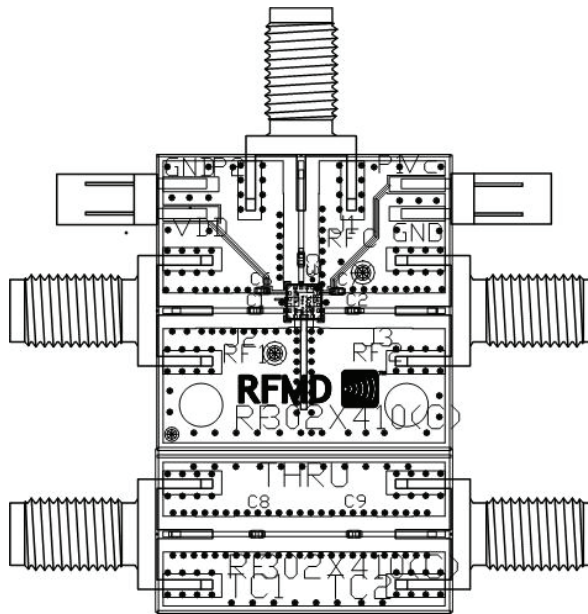

Broadband Application Circuit (500MHz to 4000MHz) - all capacitors are 100pF. Operation outside this band requires re-optimization of the capacitors.

### Truth Table

$V_C$	RFC-RF1	RFC-RF2
0	OFF	ON
1	ON	OFF

Logic '0':  $0V < V_C \leq 1.0V$   
 Logic '1':  $2V < V_C \leq 5V$

Evaluation Board Schematic

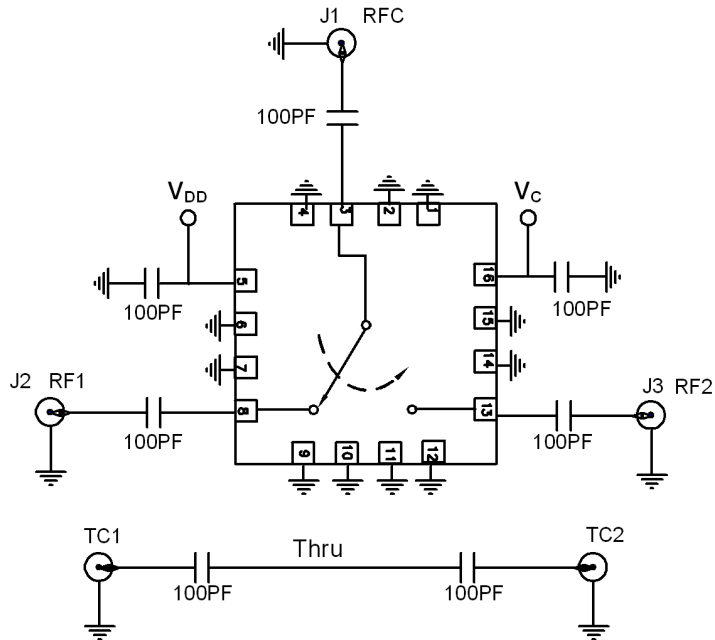

Broadband Application Circuit (500MHz to 4000MHz) - all capacitors are 100pF. Operation outside this band requires re-optimization of the capacitors.



## Pin Names and Descriptions

Pin	Name	Description
1	GND	Ground.
2	GND	Ground.
3	RFC	RF Common. External DC Block required.
4	GND	Ground.
5	VDD	Supply Voltage.
6	GND	Ground.
7	GND	Ground.
8	RF1	RF Port 1. External DC Block required.
9	GND	Ground.
10	GND	Ground.
11	GND	Ground.
12	GND	Ground.
13	RF2	RF Port 2. External DC Block required.
14	GND	Ground.
15	GND	Ground.
16	VC	Control Voltage.
17	Paddle	Ground.

## Package Drawing

Dimensions in millimeters

Refer to drawing posted at [www.rfmd.com](http://www.rfmd.com) for tolerances.

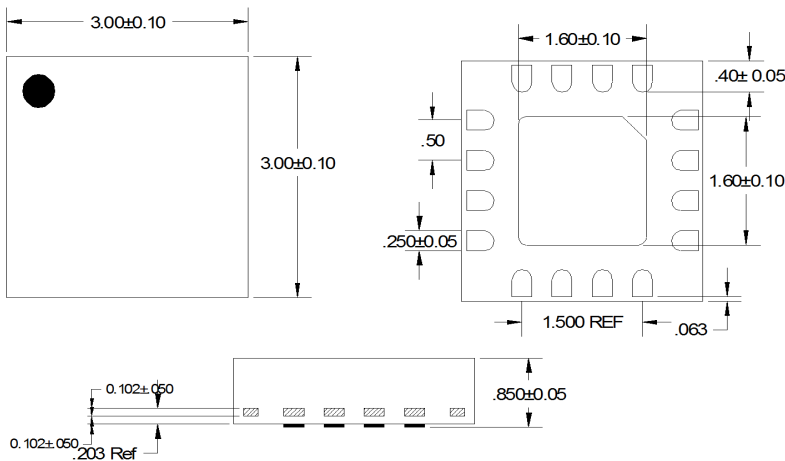

## Typical Performance - Broadband Application Circuit, $V_{DD} = 5V$

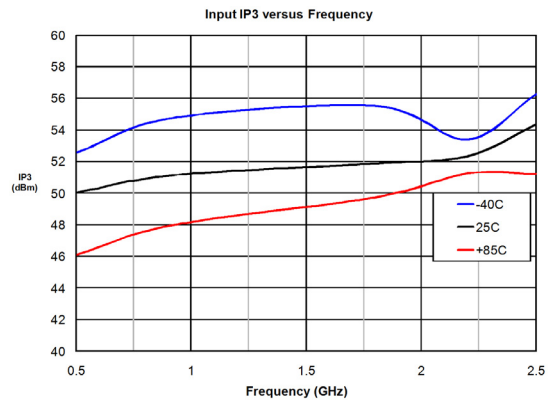
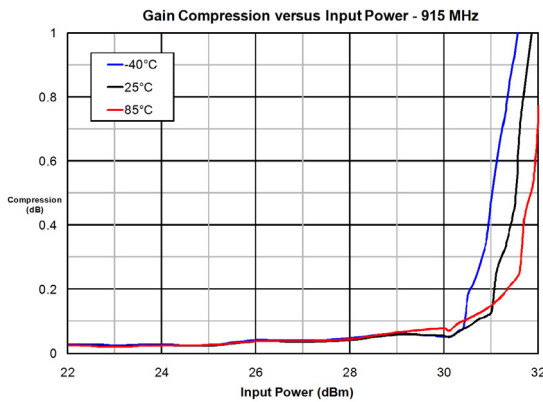
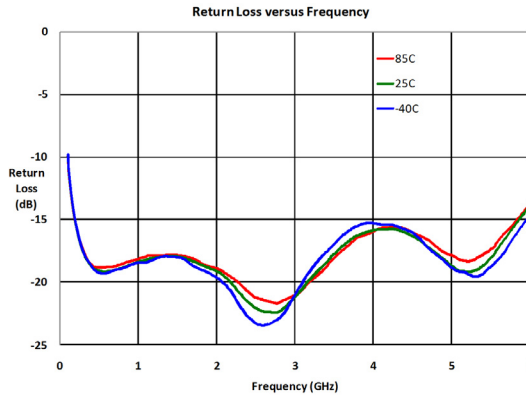
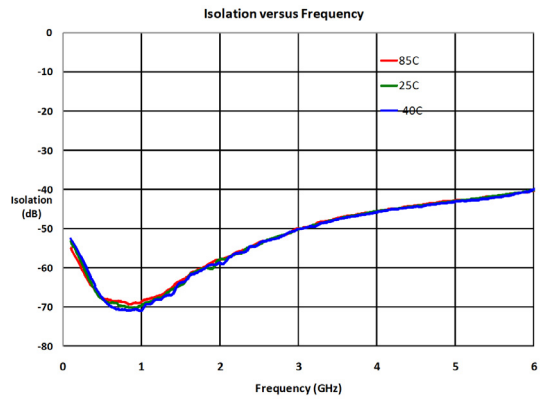
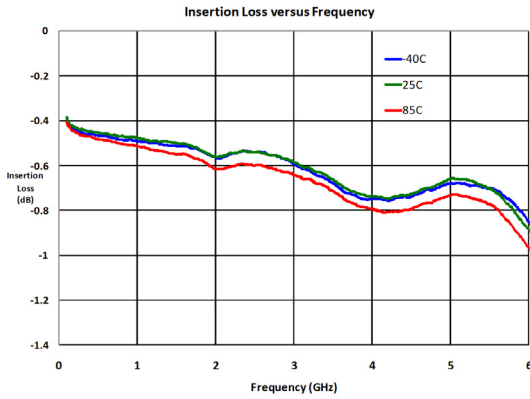

## Ordering Information

Ordering Code	Description
RF3021	Sample bag with 25 pieces
RF3021SR	7" Reel with 100 pieces
RF3021TR7	7" Reel with 2500 pieces
RF3021PCK-410	500MHz to 4000MHz PCBA with 5-piece sample bag