



Chipsmall Limited consists of a professional team with an average of over 10 year of expertise in the distribution of electronic components. Based in Hongkong, we have already established firm and mutual-benefit business relationships with customers from,Europe,America and south Asia,supplying obsolete and hard-to-find components to meet their specific needs.

With the principle of "Quality Parts,Customers Priority,Honest Operation,and Considerate Service",our business mainly focus on the distribution of electronic components. Line cards we deal with include Microchip,ALPS,ROHM,Xilinx,Pulse,ON,Everlight and Freescale. Main products comprise IC,Modules,Potentiometer,IC Socket,Relay,Connector.Our parts cover such applications as commercial,industrial, and automotives areas.

We are looking forward to setting up business relationship with you and hope to provide you with the best service and solution. Let us make a better world for our industry!



Contact us

Tel: +86-755-8981 8866 Fax: +86-755-8427 6832

Email & Skype: info@chipsmall.com Web: www.chipsmall.com

Address: A1208, Overseas Decoration Building, #122 Zhenhua RD., Futian, Shenzhen, China





Features

- Single Power Supply 3.0V to 3.6V
- 24.5 dB Minimum Gain
- Input and Output Matched to 50Ω
- 2400MHz to 2500MHz Frequency Range
- +18dBm @ <2.5% typ EVM, 120mA @ 3.3V_{CC}

Applications

- IEEE802.11b/g/n WiFi Applications
- 2.5GHz ISM Band Applications
- Commercial and Consumer Systems
- Portable Battery-Powered Equipment
- Spread-Spectrum and MMDS Systems

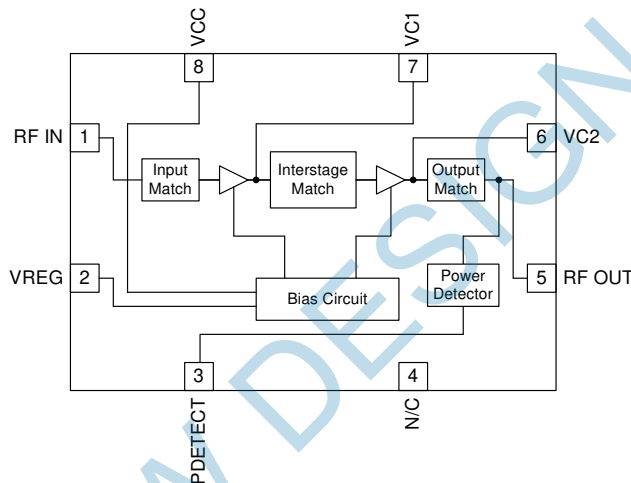

Functional Block Diagram

Product Description

The RF5122 is a linear, medium-power, high-efficiency, two-stage amplifier IC designed specifically for battery-powered WiFi applications such as PC cards, mini PCI, and compact flash applications. The device is manufactured on an advanced InGaP Gallium Arsenide Heterojunction Bipolar Transistor (HBT) process, and has been designed for use as the final RF amplifier in 2.5GHz OFDM and other spread-spectrum transmitters. The device is provided in a 2.2mmx2.2mm, 8-pin, QFN with a backside ground. The RF5122 is designed to maintain linearity over a wide range of supply voltages and power outputs. The RF5122 also has built-in power detector and incorporates the input, interstage, and output matching components internally which reduces the component count used externally and makes it easier to incorporate on any design.

Ordering Information

RF5122	Standard 25 piece bag
RF5122SR	Standard 100 piece reel
RF5122TR7	Standard 2500 piece reel
RF5122PCK-410	Fully assembled evaluation board tuned for 2.4GHz to 2.5GHz and 5 loose sample pieces

Optimum Technology Matching® Applied

- | | | | |
|---|--------------------------------------|-------------------------------------|-----------------------------------|
| <input type="checkbox"/> GaAs HBT | <input type="checkbox"/> SiGe BiCMOS | <input type="checkbox"/> GaAs pHEMT | <input type="checkbox"/> GaN HEMT |
| <input type="checkbox"/> GaAs MESFET | <input type="checkbox"/> Si BiCMOS | <input type="checkbox"/> Si CMOS | <input type="checkbox"/> RF MEMS |
| <input checked="" type="checkbox"/> InGaP HBT | <input type="checkbox"/> SiGe HBT | <input type="checkbox"/> Si BJT | <input type="checkbox"/> LDMS |

RF MICRO DEVICES®, RFMD®, Optimum Technology Matching®, Enabling Wireless Connectivity™, PowerStar®, POLARIS™ TOTAL RADIO™ and UltimateBlue™ are trademarks of RFMD, LLC. BLUETOOTH is a trademark owned by Bluetooth SIG, Inc., U.S.A. and licensed for use by RFMD. All other trade names, trademarks and registered trademarks are the property of their respective owners. ©2006, RF Micro Devices, Inc.

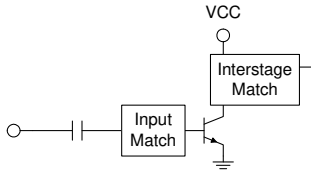
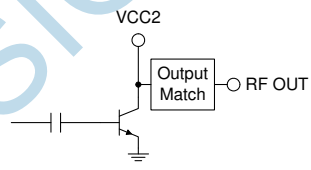
Pin	Function	Description	Interface Schematic
1	RF IN	RF input. Input is matched to 50Ω and DC block is provided internally.	
2	VREG	Bias current control voltage for the first and second amplifier stage.	
3	PDETECT	Power detector which provides an output voltage proportional to the RF output power level. May need external decoupling capacitor for stability. May need external circuitry to bring output voltage to desired level.	
4	N/C	Must be left as no connect, not grounded.	
5	RF OUT	RF output. Output is matched to 50Ω and DC block is provided internally.	
6	VC2	Voltage supply for the second amplifier stage.	
7	VC1	Voltage supply for the first amplifier stage.	
8	VCC	Supply voltage for the bias reference and control circuit. May be connected with VC1 and VC2 (with a single supply voltage) as long as VCC does not exceed +4.5V _{DC} in this configuration.	
Pkg Base	GND	The center metal base of the QFN package provides DC and RF ground as well as heat sink for the amplifier.	

Package Drawing

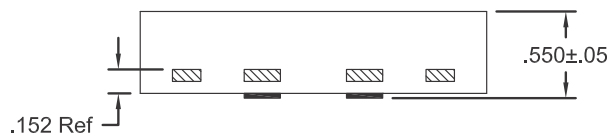
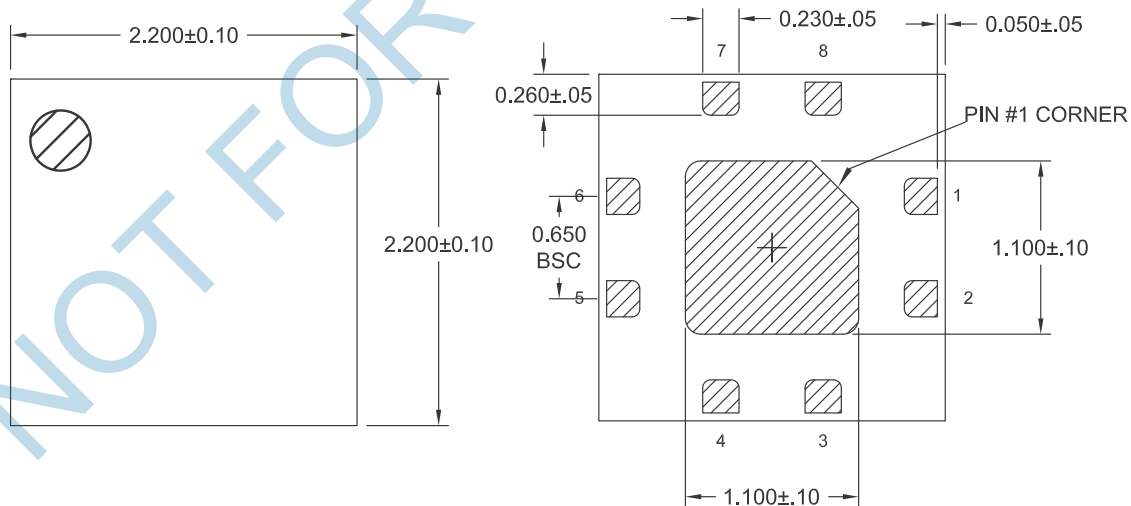

Pin Out

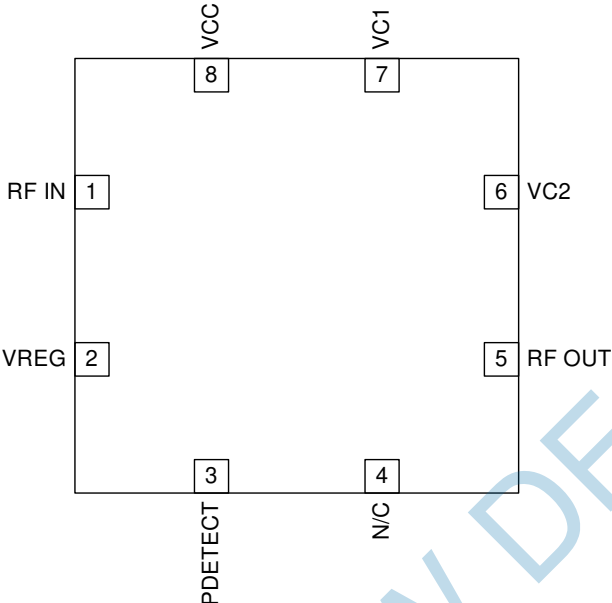

NOT FOR NEW DESIGN

Theory of Operation and Application Information

The RF5122 is a two-stage power amplifier (PA) with a minimum gain of 24.5dB minimum gain in the 2.4GHz to 2.5GHz ISM band. The RF5122 has integrated input, interstage and output matching components thus allowing minimal bill of material (BOM) parts count in end applications. The RF5122 is designed primarily for IEEE802.11b/g/n WiFi applications where the available supply voltage and current are limited. This amplifier will operate to (and below) the lowest expected voltage made available by a typical PCMCIA slot in a laptop PC, and will maintain required linearity at decreased supply voltages.

The RF5122 requires only a single positive supply of 3.3V nominal (or greater) to operate to full specifications. Power control is provided through one bias control input pin (V_{REG}). DC blocking caps are provided internally and the evaluation board circuit (available from RF Micro Devices, Inc. (RFMD)) is optimized for 3.3V_{DC} applications.

For best results, the PA circuit layout from the evaluation board should be copied as closely as possible, particularly the ground layout and ground vias. Pin 4 *must* be left as a no-connect on the PCB in order for the PA to work properly. Other configurations may also work, but the design process is much easier and quicker if the layout is copied from the RF5122 evaluation board. Gerber files of RFMD PCBA designs can be provided on request. The RF5122 is a very easy part to implement, but care in circuit layout and component selection is always advisable when designing circuits to operate at 2.5GHz. The RF5122 evaluation board layout and schematic are available using 0201 (US) size components which will help shrink the overall size of the total area of the PA and components of the intended design. Please contact RFMD Sales or Application Engineering for additional data and guidance.

For best performance, it is important to duplicate (as closely as possible) the layout of the evaluation board. The RF5122 has primarily been characterized with a voltage on V_{REG} of 2.8V_{DC}. If you prefer to use a control voltage that is significantly different than 2.8V_{DC}, or a different frequency than the recommended frequency range, contact RFMD Sales or Applications Engineering for additional data and guidance.

QFN8 Package Area versus Other Small Form Factor Package Areas

Package Type	Length (mm)	Width (mm)	Area (mm ²)	Delta (Δ) (mm ²) to QFN8
SOT 23-6	3.1	3.0	9.30	4.46
QFN12	3.0	3.0	9.00	4.16
SOT 23-5	2.9	2.8	8.12	3.28
QFN8	2.2	2.2	4.84	0.00

An application schematic for 2.5GHz operation is included that has two additional components, one shunt inductor, and one shunt capacitor, on the output for improved second harmonic rejection. This layout provides ~20dB rejection at 5GHz with a minimal BOM count.

Application Schematic for Improved Second Harmonic Performance

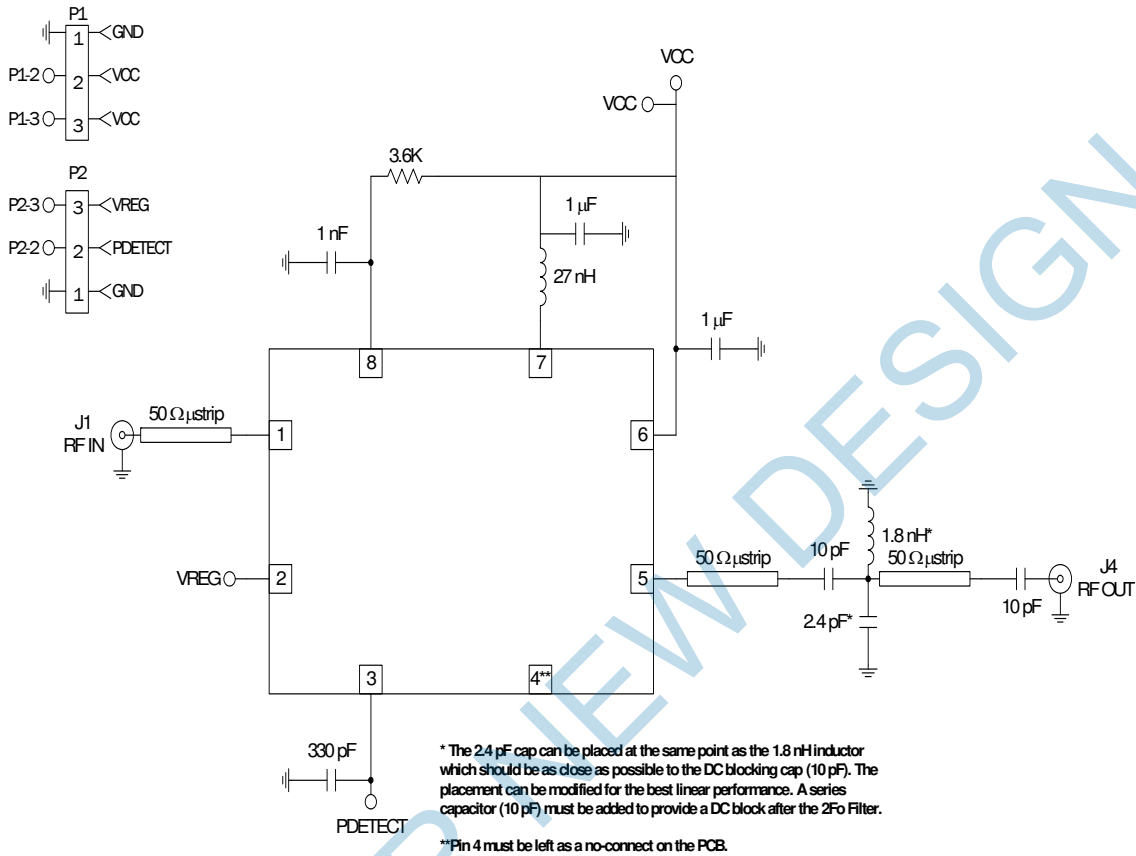

Evaluation Board Schematic

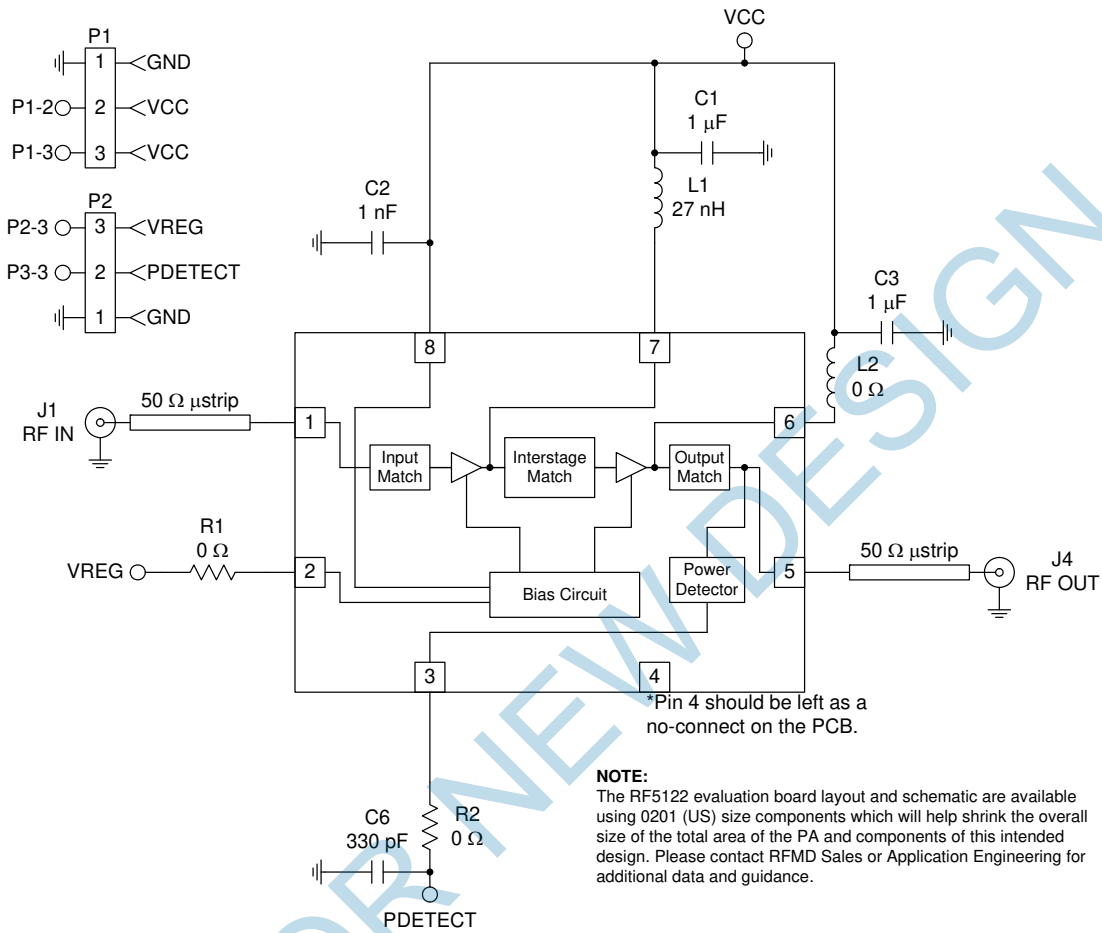

NOT FOR NEW DESIGN

Evaluation Board Layout
Board Size 1.0" x 1.0"
Board Thickness 0.031"; Board Material FR-4; Multi-Layer

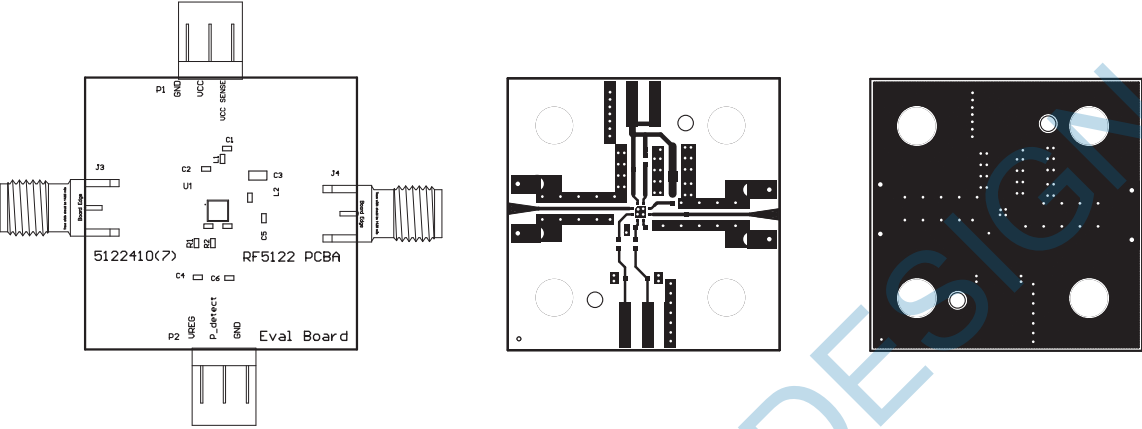

ACP versus P_{OUT}

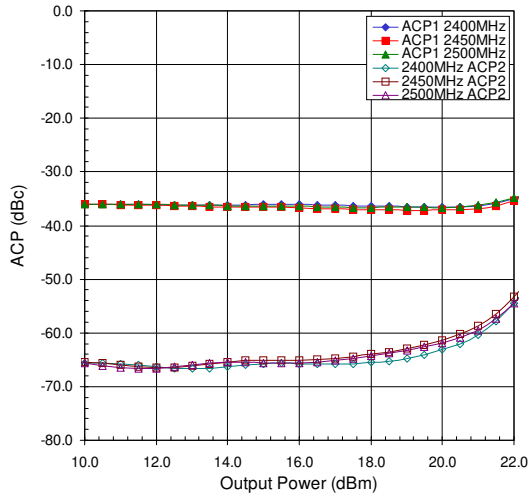

EVM versus P_{OUT}

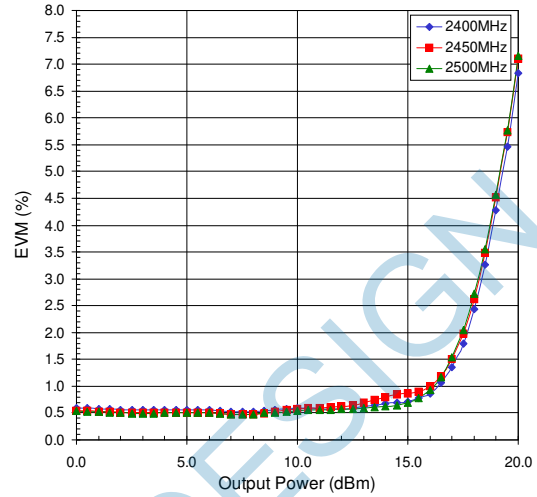

Gain versus P_{OUT}

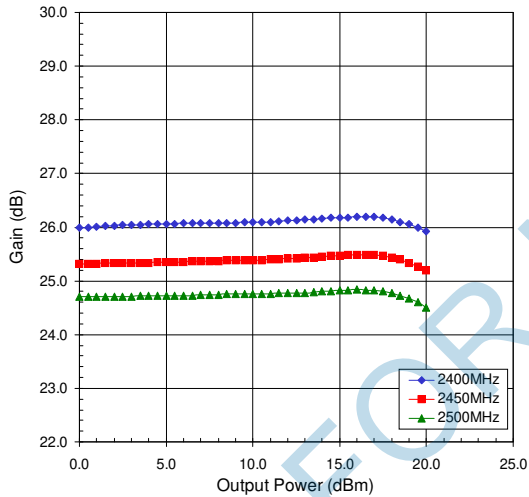

Operating Current versus P_{OUT}

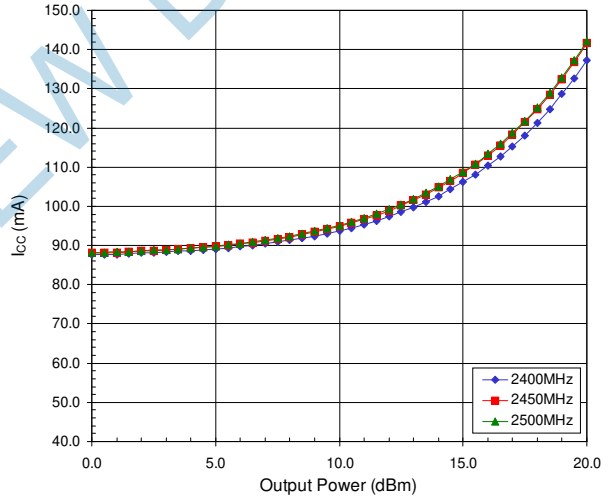

P_{DETECT} versus P_{OUT}

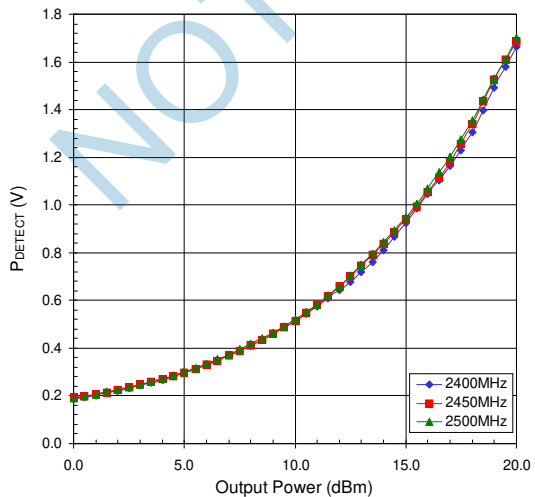

PCB Design Requirements

PCB Surface Finish

The PCB surface finish used for RFMD's qualification process is electroless nickel, immersion gold. Typical thickness is 3µinch to 8µinch gold over 180µinch nickel.

PCB Land Pattern Recommendation

PCB land patterns are based on IPC-SM-782 standards when possible. The pad pattern shown has been developed and tested for optimized assembly at RFMD; however, it may require some modifications to address company specific assembly processes. The PCB land pattern has been developed to accommodate lead and package tolerances.

PCB Solder Mask Pattern

Liquid Photo-Imageable (LPI) solder mask is recommended. The solder mask footprint will match what is shown for the PCB metal land pattern with a 2mil to 3mil expansion to accommodate solder mask registration clearance around all pads. The center-grounding pad shall also have a solder mask clearance. Expansion of the pads to create solder mask clearance can be provided in the master data or requested from the PCB fabrication supplier.

PCB Metal Land and Solder Pattern

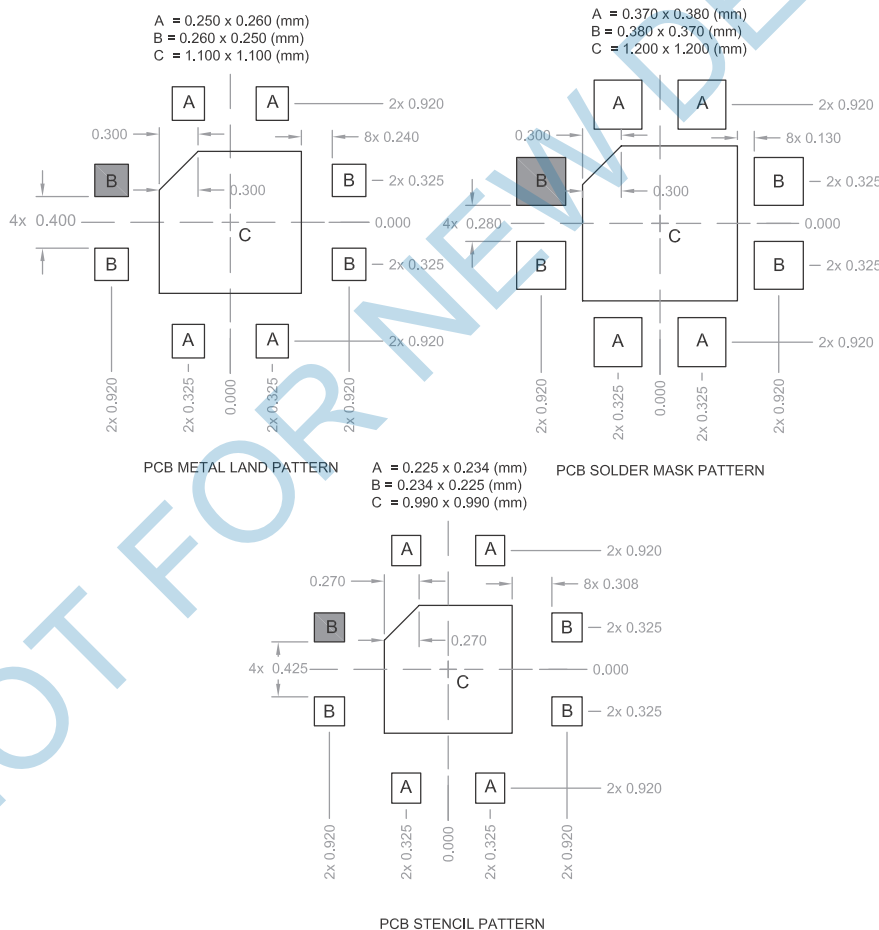

Note:
 Shaded area represents Pin 1.

Thermal vias for center slug "C" should be incorporated into the PCB design. The number and size of thermal vias will depend on the application, the power dissipation, and this electrical requirements. Example of the number and size of vias can be found on the RFMD evaluation board layout.

RoHS* Banned Material Content

RoHS Compliant: Yes
 Package total weight in grams (g): 0.008
 Compliance Date Code: N/A
 Bill of Materials Revision: -
 Pb Free Category: e3

Bill of Materials	Parts Per Million (PPM)					
	Pb	Cd	Hg	Cr VI	PBB	PB
Die	0	0	0	0	0	
Molding Compound	0	0	0	0	0	
Lead Frame	0	0	0	0	0	
Die Attach Epoxy	0	0	0	0	0	
Wire	0	0	0	0	0	
Solder Plating	0	0	0	0	0	

This RoHS banned material content declaration was prepared solely on information, including ana data, provided to RFMD by its suppliers, and applies to the Bill of Materials (BOM) revision no

* DIRECTIVE 2002/95/EC OF THE EUROPEAN PARLIAMENT AND OF THE COUNCIL of 27 January 2003 on the restriction c use of certain hazardous substances in electrical and electronic equipment

NOT FOR NEW DESIGN