



Chipsmall Limited consists of a professional team with an average of over 10 year of expertise in the distribution of electronic components. Based in Hongkong, we have already established firm and mutual-benefit business relationships with customers from,Europe,America and south Asia,supplying obsolete and hard-to-find components to meet their specific needs.

With the principle of “Quality Parts,Customers Priority,Honest Operation,and Considerate Service”,our business mainly focus on the distribution of electronic components. Line cards we deal with include Microchip,ALPS,ROHM,Xilinx,Pulse,ON,Everlight and Freescale. Main products comprise IC,Modules,Potentiometer,IC Socket,Relay,Connector.Our parts cover such applications as commercial,industrial, and automotives areas.

We are looking forward to setting up business relationship with you and hope to provide you with the best service and solution. Let us make a better world for our industry!



Contact us

Tel: +86-755-8981 8866 Fax: +86-755-8427 6832

Email & Skype: info@chipsmall.com Web: www.chipsmall.com

Address: A1208, Overseas Decoration Building, #122 Zhenhua RD., Futian, Shenzhen, China



RF6504

3.3V to 4.0V, 433MHz to 470MHz
Transmit/Receive Front End Module

RF6504 is a front end module (FEM) intended for 433MHz to 470MHz AMI/AMR systems. This module provides separate ports for Rx and Tx paths. The Tx section provides a PA with nominal output power of 30dBm and gain of 15dB. The Rx is a pass through. Both are combined to a single antenna port with a SP2T switch. The device is provided in a 5.5mm x 5.0mm, 28-pin package.



Package: LGA, 28-pin,
5.5mm x 5.0mm

Features

- Tx Output Power: 30dBm
- Separate 50Ω Tx/Rx Transceiver Interface
- Rx Insertion Loss: 1dB

Applications

- Wireless Automated Metering
- Wireless Alarm Systems
- Portable Battery Powered Equipment
- Smart Energy
- 433MHz/450MHz to 470MHz ISM Band Application
- Single Chip RF Front End Module

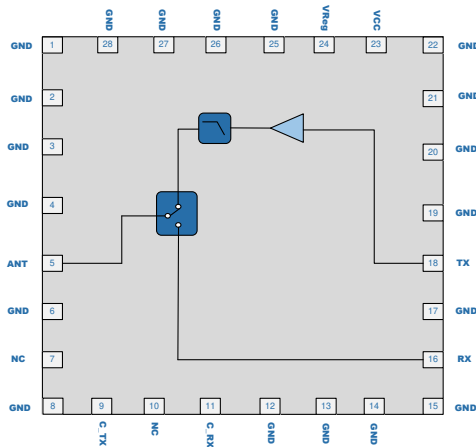

Functional Block Diagram

Ordering Information

RF6504SB	Standard 5 piece bag
RF6504SQ	Standard 25 piece bag
RF6504SR	Standard 100 piece reel
RF6504TR7	Standard 750 piece reel
RF6504TR13	Standard 2500 piece reel
RF6504PCK-410	Fully assembled evaluation board w/5 piece bag

Absolute Maximum Ratings

Parameter	Rating	Unit
Battery Voltage	5	V
RF Port Impedance	50	Ω
Operating Temperature	-40 to +70C 100% Duty Cycle	$^{\circ}\text{C}$
	+70 to +85C \leq 90% Duty Cycle	
Storage Temperature	-40 to 85	$^{\circ}\text{C}$
ESD, HBM (RF pins)	500	V
ESD, HBM (All pins)	500	V
ESD, CDN (RF pins)	500	V
ESD, CDM (all pins)	500	V
MSL	MSL 3	
Maximum Input Power to PA	+20	dBm



Caution! ESD sensitive device.



RFMD Green: RoHS status based on EU Directive 2011/65/EU (at time of this document revision), halogen free per IEC 61249-2-21, < 1000ppm each of antimony trioxide in polymeric materials and red phosphorus as a flame retardant, and <2% antimony in solder.

Exceeding any one or a combination of the Absolute Maximum Rating conditions may cause permanent damage to the device. Extended application of Absolute Maximum Rating conditions to the device may reduce device reliability. Specified typical performance or functional operation of the device under Absolute Maximum Rating conditions is not implied.

Nominal Operating Parameters

Parameter	Specification			Unit	Condition
	Min	Typ	Max		
					Specifications are at nominal supply voltage, control voltage, and temperature. Characterization will be done over full voltage and temperature range specified
Frequency	433	450 to 470		MHz	
RF Port Impedance		50		W	
Total Leakage Current		4	5	mA	$V_{\text{REG}} = 0\text{V}$
ESD, HBM	500			V	RF pins
	500			V	All other pins
ESD, CDM	500			V	RF pins
	500			V	All other pins
PA Section					
CW P_{OUT} Saturation	30			dBm	PA $P_{\text{SAT}} - \text{Sw}(1\text{dB}) - \text{Filt}(1\text{dB})$
Large Signal Gain	13	15		dB	Input PA to Output of Switch
Input Power	17			dBm	
2Fo to 10Fo	-54	-60		dBc	
Input Return Loss	10			dB	
Battery Voltage	3.3	3.6	4.0	V	V_{CC}
Battery Current		700	800	mA	$V_{\text{CC}} = 3.6\text{V}$, PA PAE 55%
Power Down Current		0.3	2	mA	$V_{\text{CC}} = 3.6\text{V}$, $V_{\text{REG}} = 0\text{V}$
V_{REG}	3.1	3.4	$V_{\text{CC}} - 0.2$	V	
V_{REG} Current		3	4	mA	
RX Section					
Noise Figure		0.7	1	dB	
Input IP3	12	18		dBm	
Input Return Loss	10			dB	
Output Return Loss	10			dB	

Parameter	Specification			Unit	Condition
	Min	Typ	Max		

Switch Section					
Isolation	20			dB	Any used port to any unused port
Logic Voltage, High	3.1	3.4	$V_{CC}-0.2$	V	All Logic I/O's
Logic Voltage, Low	0.0	0.2	0.4	V	All Logic I/O's
Logic Current, High		5	10	mA	All Logic I/O's
Logic Current, Low		0.4		mA	All Logic I/O's

Module Logic Truth Table

Operating Mode	C_TX	C_RX	Typ. Battery Current at POUT = 30dBm
TX-ANT	1	0	850mA
RX-ANT	0	1	0.3mA

Typical Performance

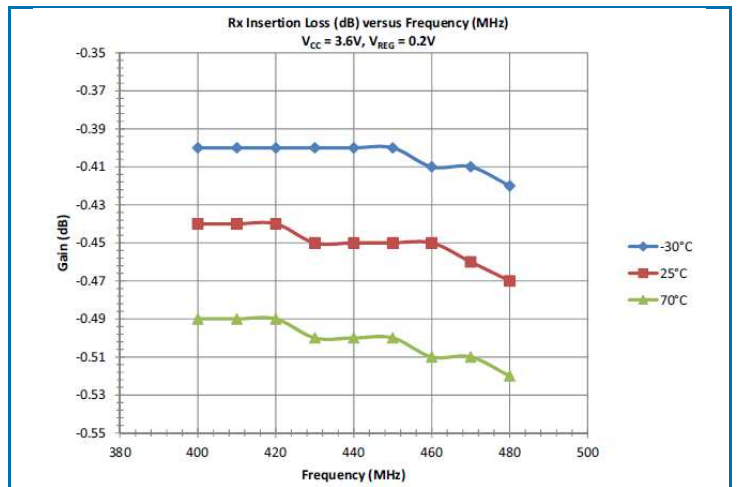
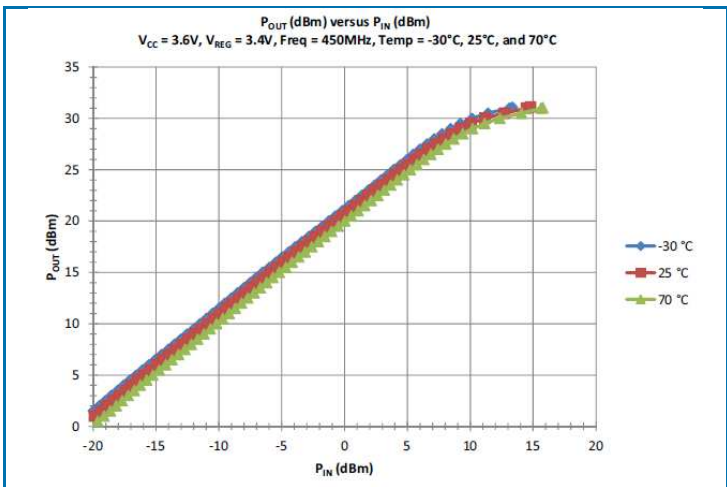
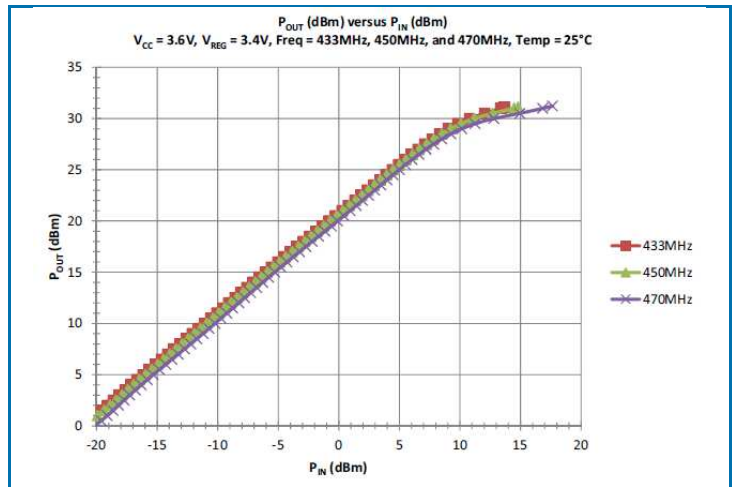
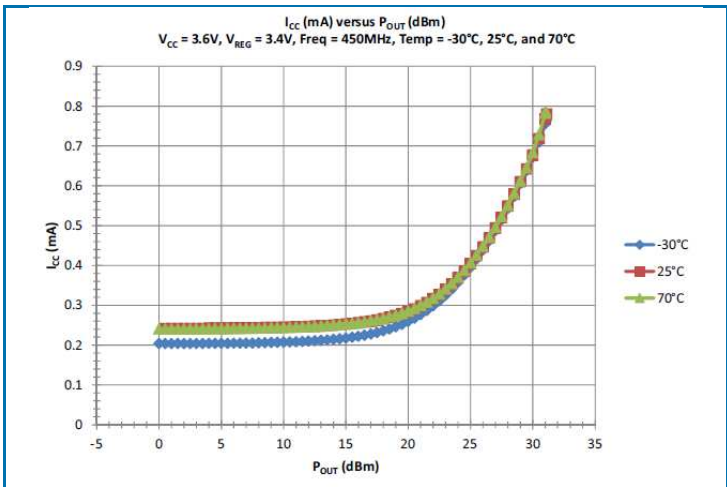
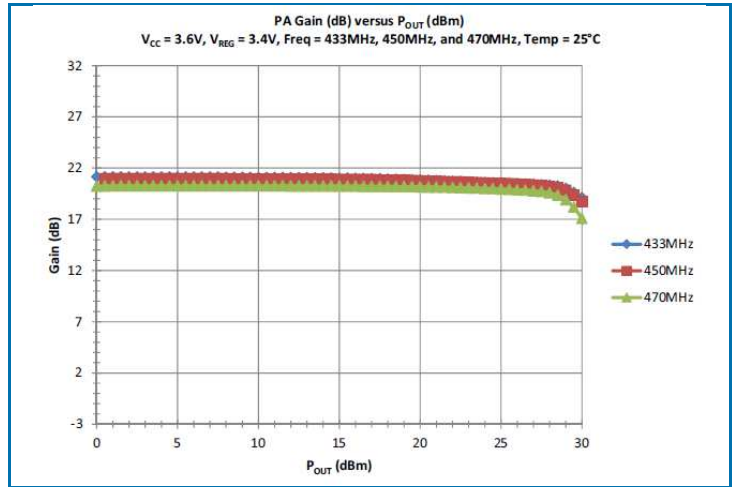
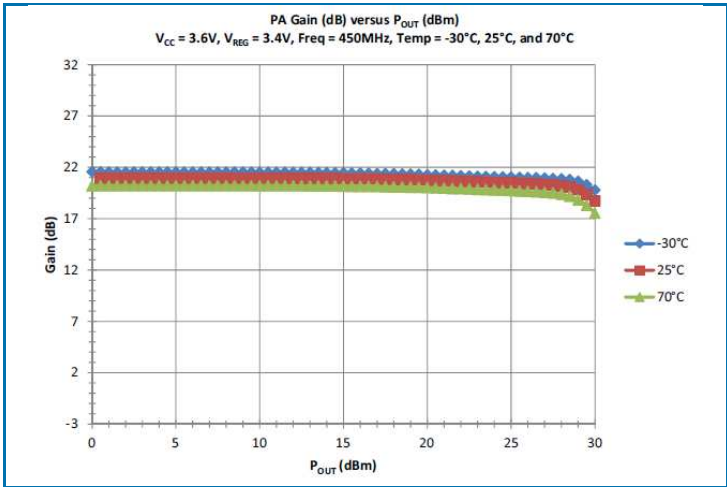

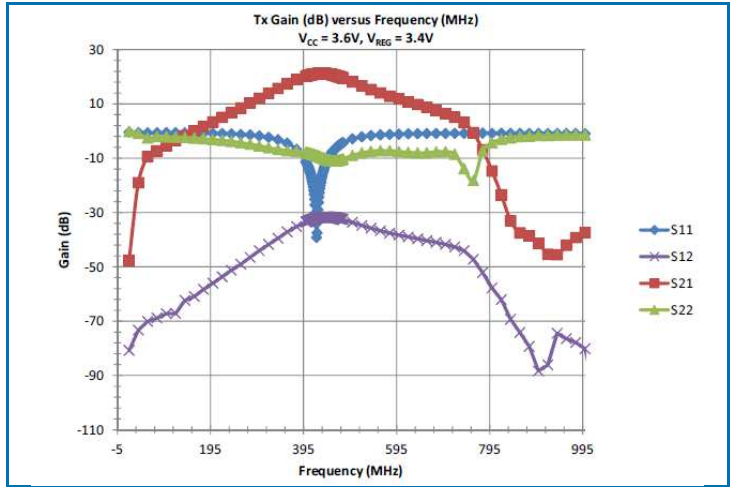
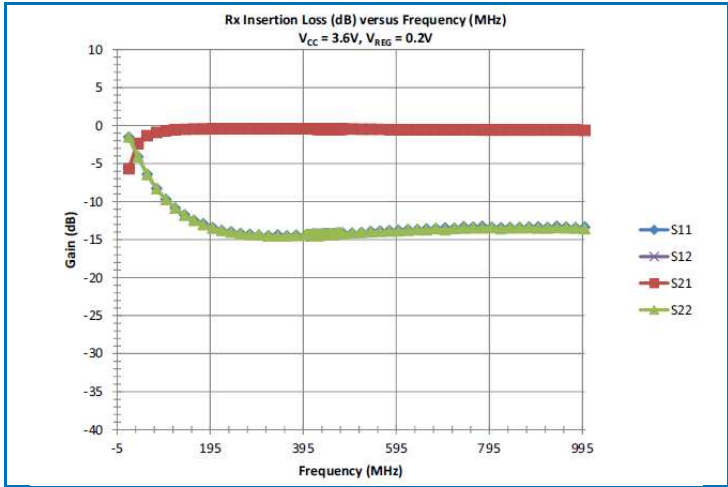

Application Schematic

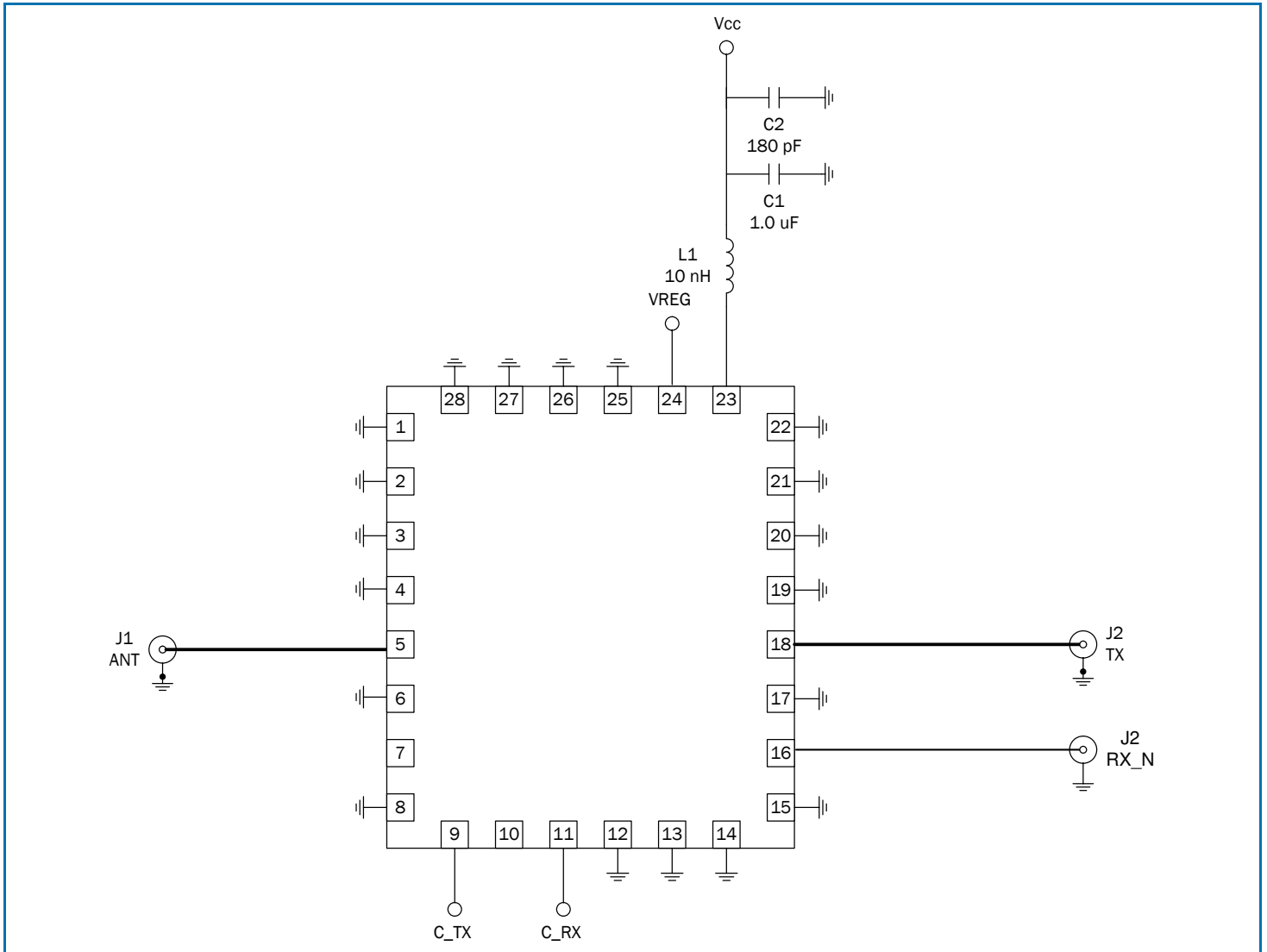

Pin Out

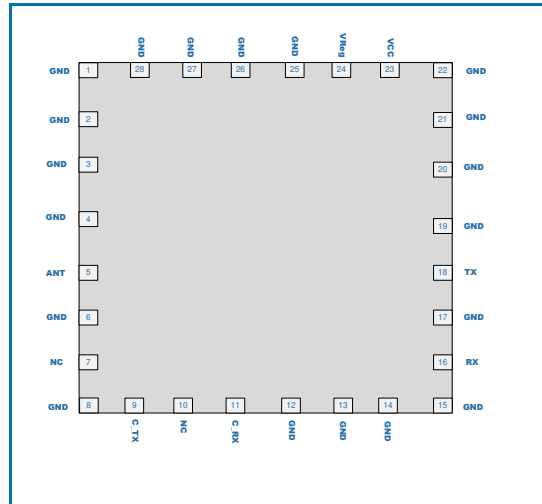

Package Drawing

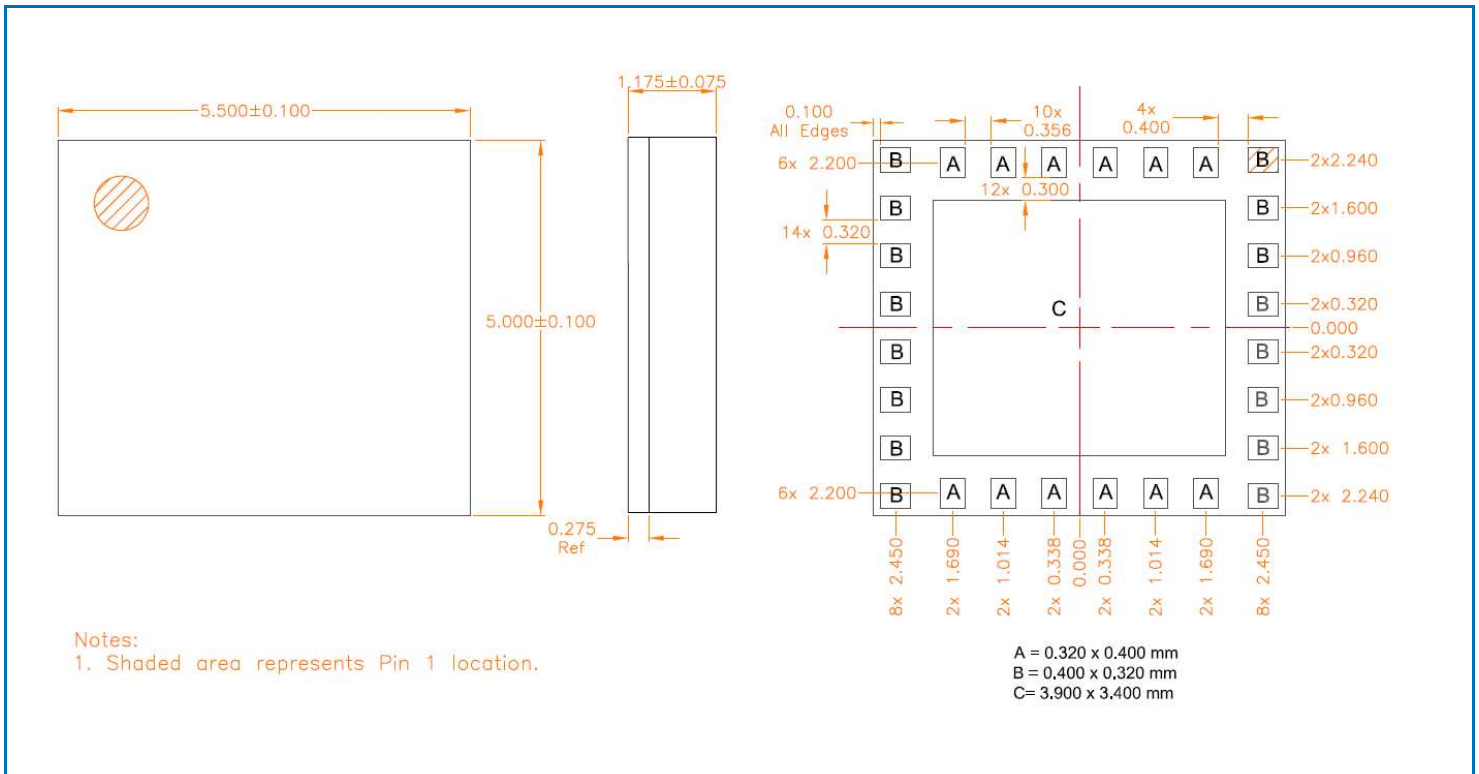

All units in μm .

PCB Patterns

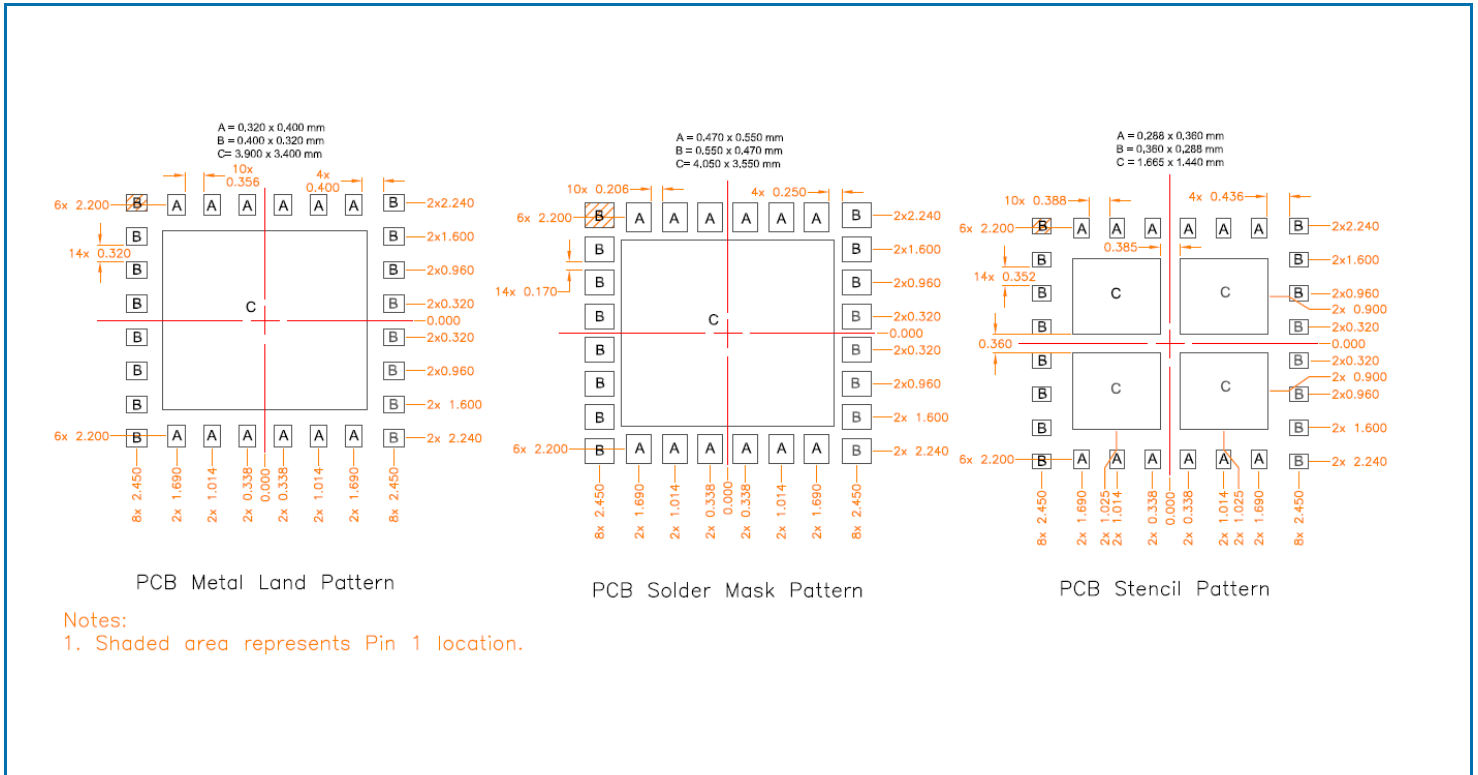

Pin Names and Descriptions

Pin	Name	Description
5	ANT	Antenna Connect Port.
9	C_TX	Transmit Selection Control Line.
11	C_RX	Receive Selection Control Line.
16	RX	Receive Port.
18	TX	Transmit Port.
23	VCC	Power Amplifier Supply Voltage.
24	VREG	Power Amplifier Bias Control. V_{CC} to 0.2V = ON, 0V = OFF.
7, 10	NC	
1, 2, 3, 4, 6, 8, 12, 13, 14, 15, 17, 19, 20, 21, 22, 25, 26, 27, 28	GND	Ground.