



Chipsmall Limited consists of a professional team with an average of over 10 year of expertise in the distribution of electronic components. Based in Hongkong, we have already established firm and mutual-benefit business relationships with customers from,Europe,America and south Asia,supplying obsolete and hard-to-find components to meet their specific needs.

With the principle of “Quality Parts,Customers Priority,Honest Operation,and Considerate Service”,our business mainly focus on the distribution of electronic components. Line cards we deal with include Microchip,ALPS,ROHM,Xilinx,Pulse,ON,Everlight and Freescale. Main products comprise IC,Modules,Potentiometer,IC Socket,Relay,Connector.Our parts cover such applications as commercial,industrial, and automotives areas.

We are looking forward to setting up business relationship with you and hope to provide you with the best service and solution. Let us make a better world for our industry!



Contact us

Tel: +86-755-8981 8866 Fax: +86-755-8427 6832

Email & Skype: info@chipsmall.com Web: www.chipsmall.com

Address: A1208, Overseas Decoration Building, #122 Zhenhua RD., Futian, Shenzhen, China





Features

- TD-SCDMA Compliant B34/39
- TD-HSDPA and TD-HSPA+ Compliant
- +25 dBm Output Power TD-SCDMA
- Low Gain Mode for reduced I_{CQ}
- High Efficiency at Rated P_{OUT}
 - $V_{BATT}=3.5V$
 - GSM850/EGSM900=41/40%
 - DCS1800/PCS1900=38/36%
- Integrated Power Flattening Circuit for Lower Power Variation Under Mismatch Conditions
- Integrated V_{BATT} Tracking Circuit for improved Switching Spectrum under low V_{BATT} Conditions
- Symmetrical RX Ports
- Robust 8kV ESD Protection at Antenna Port
- Pin Compatible with RF9810

Applications

- 3.2V Quad-Band GSM/GPRS/EDGE and Dual-Band TD-SCDMA Handsets
- Mobile GPRS/EDGE/TD-SCDMA Data Products
- GPRS Class 12 Compliant Products

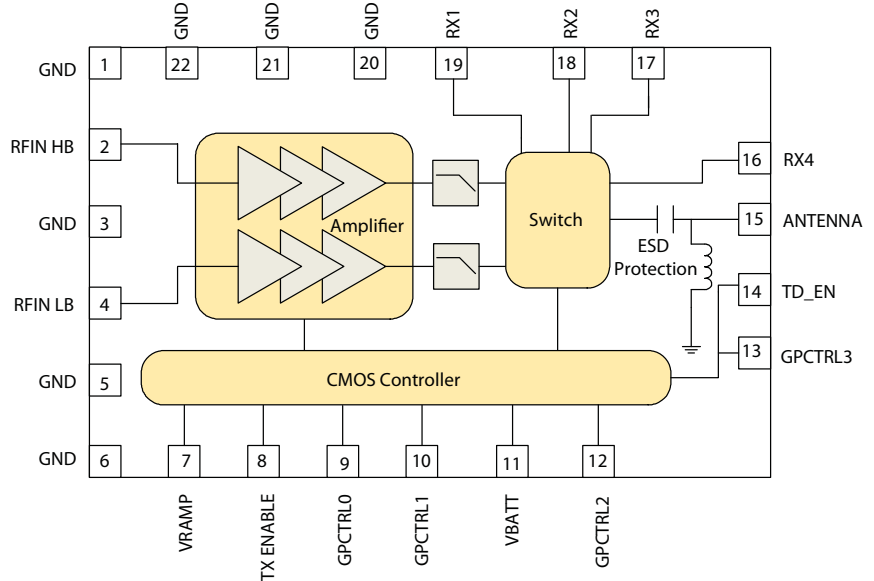

Functional Block Diagram

Product Description

The RF9812 is a Quad Band EDGE+TD-SCDMA Multi-Mode Transmit Module with the capability to support both GSM/GPRS/Linear EDGE (GSM850/EGSM900/DCS1800/PCS1900) and TDSCDMA (1880MHz to 1920MHz and 2010MHz to 2025MHz) B34/39 frequency bands. The RF9812 continues to build upon RFMD's leading patented PowerStar® Architecture to include such features as a Power Flattening Circuit, V_{RAMP} Filtering, V_{BATT} Tracking, EDGE Low Power Mode. RFMD has integrated TD-SCDMA functionality into the RF9812, so it can be used as the transmit module in 3.2V, 50Ω GSM/EDGE/TD-SCDMA dual-mode cellular equipment.

The RF9812 module includes a multi-function CMOS controller, GaAs HBT power amplifier, and pHEMT front end antenna switch. The amplifier devices are manufactured on RFMD's Advance Gallium Arsenide Heterojunction Bipolar Transistor (GaAs HBT) Process, which is designed to operate either in saturated mode for GMSK or linear mode for EDGE 8PSK and TD-SCDMA signaling. The highly integrated EDGE+TD-SCDMA transmit module simplifies GSM/TD-SCDMA dual-mode handset and data card design by eliminating the need for complicated control loop design, output RF spectrum (ORFS) optimization, harmonic filtering, and component matching, all of which combine to provide best in class RF performance, solution size, and ease of implementation for GSM/EDGE/TD-SCDMA dual-mode cellular phone and data card systems. The RF ports are 50Ω matched and the antenna port includes ESD protection circuitry which meets the stringent 8kV industry standards requiring no additional components. All of these eliminated factors help to improve the customer's product time to market.

Optimum Technology Matching® Applied

- | | | | |
|--|--------------------------------------|--|-----------------------------------|
| <input checked="" type="checkbox"/> GaAs HBT | <input type="checkbox"/> SiGe BiCMOS | <input checked="" type="checkbox"/> GaAs pHEMT | <input type="checkbox"/> GaN HEMT |
| <input type="checkbox"/> GaAs MESFET | <input type="checkbox"/> Si BiCMOS | <input checked="" type="checkbox"/> Si CMOS | <input type="checkbox"/> RF MEMS |
| <input type="checkbox"/> InGaP HBT | <input type="checkbox"/> SiGe HBT | <input type="checkbox"/> Si BJT | <input type="checkbox"/> LD MOS |

RF MICRO DEVICES®, RFMD®, Optimum Technology Matching®, Enabling Wireless Connectivity™, PowerStar®, POLARIS™ TOTAL RADIO™ and UltimateBlue™ are trademarks of RFMD, LLC. BLUETOOTH is a trademark owned by Bluetooth SIG, Inc., U.S.A. and licensed for use by RFMD. All other trade names, trademarks and registered trademarks are the property of their respective owners. ©2012, RF Micro Devices, Inc.

RF9812



rfmd.com

**Please contact
RFMD Technical Support
at (336) 678-5570
for more information.**