



Chipsmall Limited consists of a professional team with an average of over 10 year of expertise in the distribution of electronic components. Based in Hongkong, we have already established firm and mutual-benefit business relationships with customers from,Europe,America and south Asia,supplying obsolete and hard-to-find components to meet their specific needs.

With the principle of "Quality Parts,Customers Priority,Honest Operation,and Considerate Service",our business mainly focus on the distribution of electronic components. Line cards we deal with include Microchip,ALPS,ROHM,Xilinx,Pulse,ON,Everlight and Freescale. Main products comprise IC,Modules,Potentiometer,IC Socket,Relay,Connector.Our parts cover such applications as commercial,industrial, and automotives areas.

We are looking forward to setting up business relationship with you and hope to provide you with the best service and solution. Let us make a better world for our industry!



## Contact us

Tel: +86-755-8981 8866 Fax: +86-755-8427 6832

Email & Skype: info@chipsmall.com Web: www.chipsmall.com

Address: A1208, Overseas Decoration Building, #122 Zhenhua RD., Futian, Shenzhen, China



# APPROVAL SHEET

## **MULTILAYER CERAMIC NOTCH FILTER**

### **RFDIP Series – 1608(0603)- RoHS Compliance**

Halogens Free Product

2.4 GHz & 5 GHz ISM Band Working Frequency

**P/N: RFDIP1608060L3T**

\*Contents in this sheet are subject to change without prior notice.

**Approval sheet**

**FEATURES**

- Miniature footprint: 1.6 X 0.8X 0.6 mm<sup>3</sup>
- Low Insertion Loss
- High attenuation on 2<sup>nd</sup> harmonic suppressed
- LTCC process

**APPLICATIONS**

- ISM 2.4/ 5GHz band RF application
- Wi-Fi 802.11a/b/g/n application

**CONSTRUCTION**

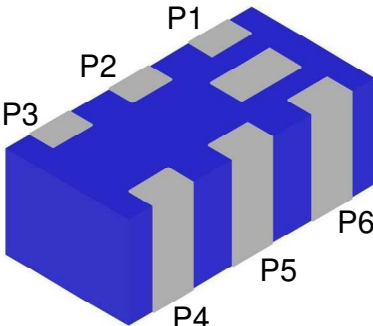
Figure	PIN	Connection
	1	2.4GHz Port
	2	GND
	3	5GHz Port
	4	GND
	5	ANT
	6	GND

**DIMENSIONS**

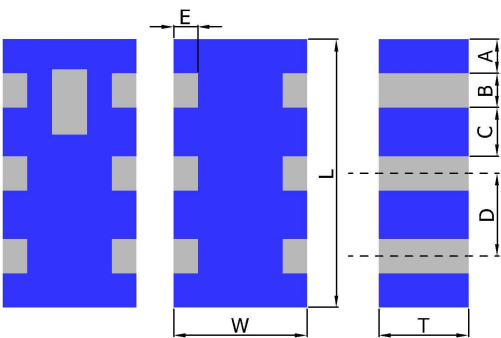
Figure	Symbol	Dimension (mm)
	L	1.60 ± 0.15
	W	0.80 ± 0.15
	T	0.60 ± 0.10
	A	0.175 ± 0.15
	B	0.25 ± 0.15
	C	0.25 ± 0.15
	D	0.50 ± 0.15
	E	0.20 ± 0.15

**ELECTRICAL CHARACTERISTICS**

Item	Specification	
Frequency range (MHz)	2400-2500	4900-5900
VSWR	2.0 max	2.0 max
Insertion Loss (dB)	0.8 dB max.	1.2 dB max
Attenuation (dB min.)	18 min. @4.8~5.0GHz 20 min. @7.2~7.5GHz	20 min. @3.7~3.9GHz 20 min. @1.8~2.5GHz 20 min. @9.8~11.8GHz

**TYPICAL ELECTRICAL PERFORMANCE**

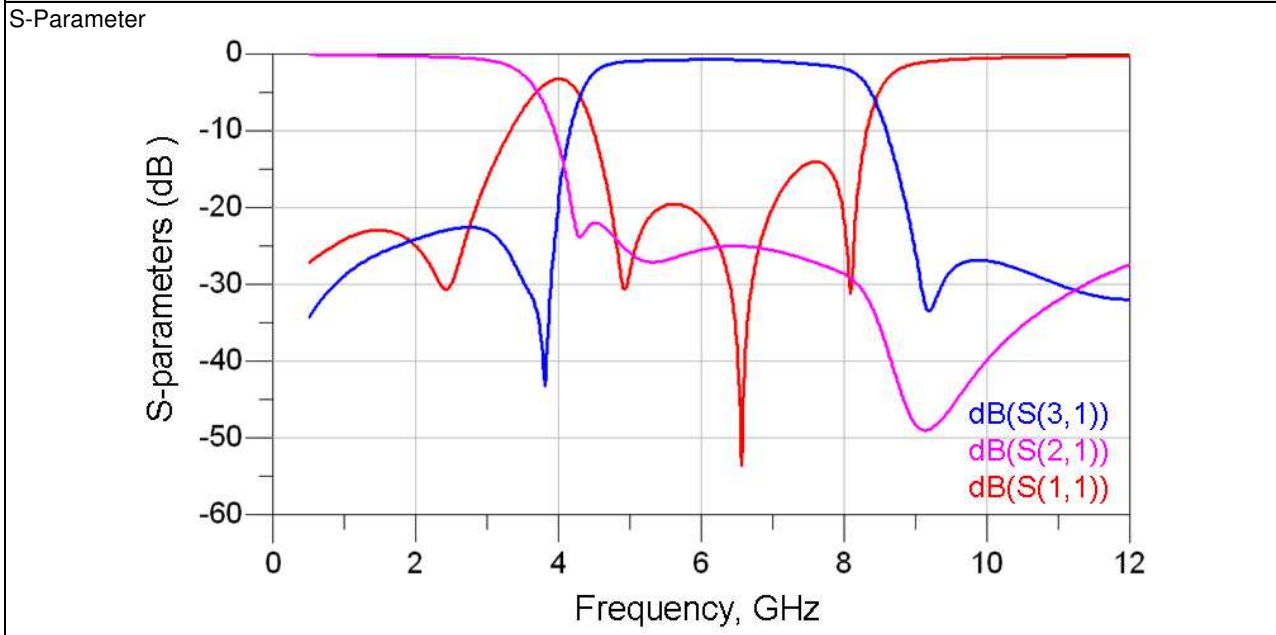

**SOLDER LAND PATTERN**

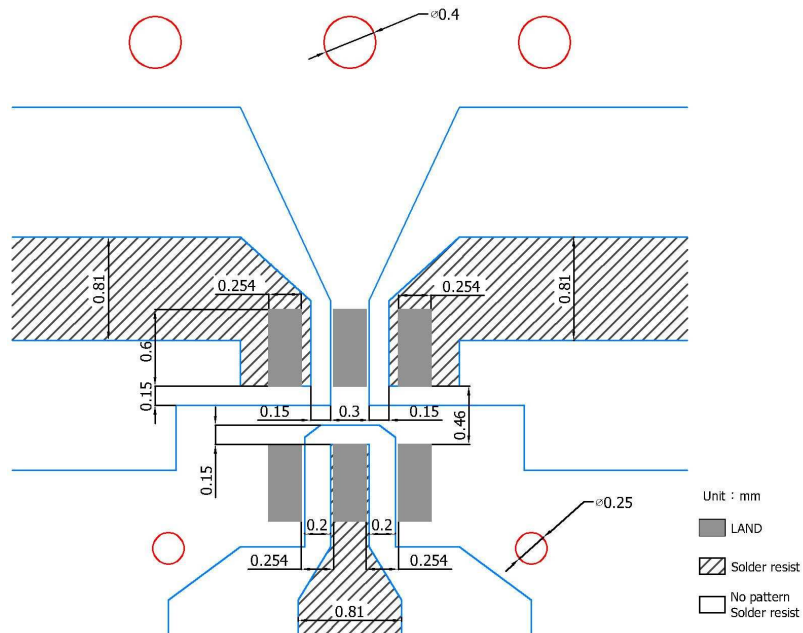

Line width to be designed to match 50 Ω characteristic impedance, depending on PCB material and thickness. Grounding through holes is 0.3 mm

## RELIABILITY TEST

Test item	Test condition / Test method	Specification
Solderability JIS C 0050-4.6 JESD22-B102D	*Solder bath temperature : $235 \pm 5^{\circ}\text{C}$ *Immersion time : $2 \pm 0.5$ sec *Solder : Sn3Ag0.5Cu for lead-free	At least 95% of a surface of each terminal electrode must be covered by fresh solder.
Leaching (Resistance to dissolution of metallization) IEC 60068-2-58	*Solder bath temperature : $260 \pm 5^{\circ}\text{C}$ *Leaching immersion time : $30 \pm 0.5$ sec *Solder : SN63A	Loss of metallization on the edges of each electrode shall not exceed 25%.
Resistance to soldering heat JIS C 0050-5.4	*Preheating temperature : $120\sim 150^{\circ}\text{C}$ , 1 minute. *Solder temperature : $270\pm 5^{\circ}\text{C}$ *Immersion time : $10\pm 1$ sec *Solder : Sn3Ag0.5Cu for lead-free Measurement to be made after keeping at room temperature for $24\pm 2$ hrs	No mechanical damage. Samples shall satisfy electrical specification after test. Loss of metallization on the edges of each electrode shall not exceed 25%.
Drop Test JIS C 0044	*Height : 75 cm *Test Surface : Rigid surface of concrete or steel. *Times : 6 surfaces for each units ; 2 times for each side.	No mechanical damage. Samples shall satisfy electrical specification after test.
Adhesive Strength of Termination JIS C 0051- 7.4.3	*Pressurizing force : $5\text{N}(\leq 0603)$ ; $10\text{N}(>0603)$ *Test time : $10\pm 1$ sec	No remarkable damage or removal of the termination.
Bending test JIS C 0051- 7.4.1	The middle part of substrate shall be pressurized by means of the pressurizing rod at a rate of about 1 mm/s per second until the deflection becomes 1mm/s and then pressure shall be maintained for $5\pm 1$ sec. Measurement to be made after keeping at room temperature for $24\pm 2$ hours	No mechanical damage. Samples shall satisfy electrical specification after test.

Approval sheet

<p>Temperature cycle JIS C 0025</p>	<p>1. 30±3 minutes at -40°C±3°C, 2. 10~15 minutes at room temperature, 3. 30±3 minutes at +85°C±3°C, 4. 10~15 minutes at room temperature, Total 100 continuous cycles Measurement to be made after keeping at room temperature for 24±2 hrs</p>	<p>No mechanical damage. Samples shall satisfy electrical specification after test.</p>
<p>Vibration JIS C 0040</p>	<p>*Frequency : 10Hz~55Hz~10Hz(1min) *Total amplitude : 1.5mm *Test times : 6hrs.(Two hrs each in three mutually perpendicular directions)</p>	<p>No mechanical damage. Samples shall satisfy electrical specification after test.</p>
<p>High temperature JIS C 0021</p>	<p>*Temperature : 85°C±2°C *Test duration : 1000+24/-0 hours Measurement to be made after keeping at room temperature for 24±2 hrs</p>	<p>No mechanical damage. Samples shall satisfy electrical specification after test.</p>
<p>Humidity (steady conditions) JIS C 0022</p>	<p>*Humidity : 90% to 95% R.H. *Temperature : 40±2°C *Time : 1000+24/-0 hrs. Measurement to be made after keeping at room temperature for 24±2 hrs ※ 500hrs measuring the first data then 1000hrs data</p>	<p>No mechanical damage. Samples shall satisfy electrical specification after test.</p>
<p>Low temperature JIS C 0020</p>	<p>*Temperature : -40°C±2°C *Test duration : 1000+24/-0 hours Measurement to be made after keeping at room temperature for 24±2 hrs</p>	<p>No mechanical damage. Samples shall satisfy electrical specification after test.</p>

**SOLDERING CONDITION**

Typical examples of soldering processes that provide reliable joints without any damage are given in Fig 2,

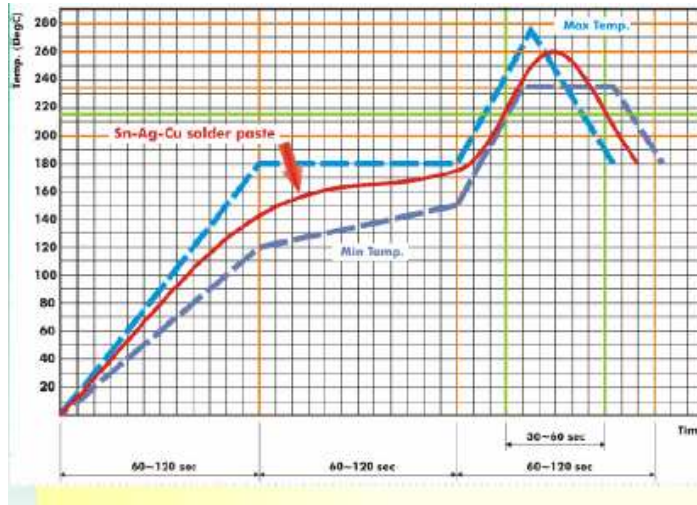

Fig 2. Infrared soldering profile

**ORDERING CODE**

<b>RF</b> Walsin RF device	<b>DIP</b> Product Code DIP : Diplexer	<b>160806</b> Dimension code Per 2 digits of Length, Width, Thickness : e.g. : 1608 = Length 16, Width 08, Thickness 06	<b>0</b> Unit of dimension 0 : 0.1 mm 1 : 1.0 mm	<b>L</b> Application L : 2.4GHz/5GHz	<b>3</b> Specification Design code	<b>T</b> Packing T : Reeled
----------------------------------	--	--	---	---	--	-----------------------------------

Minimum Ordering Quantity: 4000 pcs per reel.

**PACKAGING**

Paper Tape specifications (unit :mm)

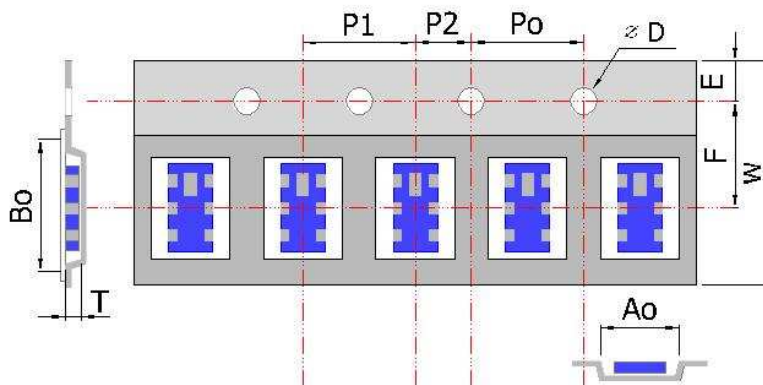

Index	Ao	Bo	ϕD	T	W
Dimension (mm)	0.975± 0.05	1.76 ±0.05	1.55 + 0.05	0.75± 0.03	8.0 ± 0.10
Index	E	F	Po	P1	P2
Dimension (mm)	1.75 ± 0.10	3.50 ± 0.05	4.00 ± 0.10	4.00 ± 0.10	2.00 ± 0.05

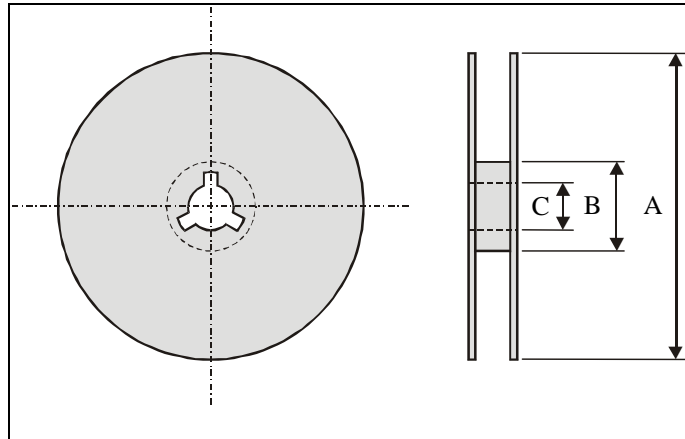
**Reel dimensions**

Index	A	B	C
Dimension (mm)	Φ178.0	Φ60.0	Φ13.0

Taping Quantity:4000 pieces per 7" reel

**CAUTION OF HANDLING****Limitation of Applications**

Please contact us before using our products for the applications listed below which require especially high reliability for the prevention of defects, which might directly cause damage to the third party's life, body or property.

- (1) Aircraft equipment
- (2) Aerospace equipment
- (3) Undersea equipment
- (4) Medical equipment
- (5) Disaster prevention / crime prevention equipment
- (6) Traffic signal equipment
- (7) Transportation equipment (vehicles, trains, ships, etc.)
- (8) Applications of similar complexity and /or reliability requirements to the applications listed in the above.

**Storage condition**

- (1) Products should be used in 6 months from the day of WALSIN outgoing inspection, which can be confirmed.
- (2) Storage environment condition.
  - Products should be storage in the warehouse on the following conditions.
  - Temperature : -10 to +40℃
  - Humidity : 30 to 70% relative humidity
  - Don't keep products in corrosive gases such as sulfur. Chlorine gas or acid or it may cause oxidization of electrode, resulting in poor solderability.
  - Products should be storage on the palette for the prevention of the influence from humidity, dust and son on.
  - Products should be storage in the warehouse without heat shock, vibration, direct sunlight and so on.
  - Products should be storage under the airtight packaged condition.