



Chipsmall Limited consists of a professional team with an average of over 10 year of expertise in the distribution of electronic components. Based in Hongkong, we have already established firm and mutual-benefit business relationships with customers from,Europe,America and south Asia,supplying obsolete and hard-to-find components to meet their specific needs.

With the principle of “Quality Parts,Customers Priority,Honest Operation,and Considerate Service”,our business mainly focus on the distribution of electronic components. Line cards we deal with include Microchip,ALPS,ROHM,Xilinx,Pulse,ON,Everlight and Freescale. Main products comprise IC,Modules,Potentiometer,IC Socket,Relay,Connector.Our parts cover such applications as commercial,industrial, and automotives areas.

We are looking forward to setting up business relationship with you and hope to provide you with the best service and solution. Let us make a better world for our industry!



Contact us

Tel: +86-755-8981 8866 Fax: +86-755-8427 6832

Email & Skype: info@chipsmall.com Web: www.chipsmall.com

Address: A1208, Overseas Decoration Building, #122 Zhenhua RD., Futian, Shenzhen, China



GEAR SPECIFICATIONS	
GEAR TYPE	SPUR
TOOTH STYLE	INVOLUTE
PRESSURE ANGLE	20°
NUMBER OF TEETH	12
PITCH CIRCLE DIAMETER	Ø.47 [Ø12]

Ø.165±.004 [4.2±0.1] TYP.

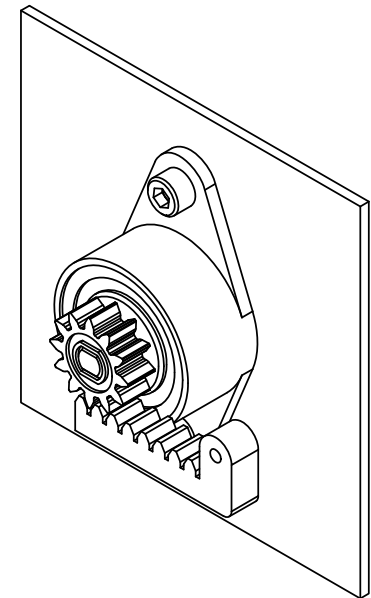
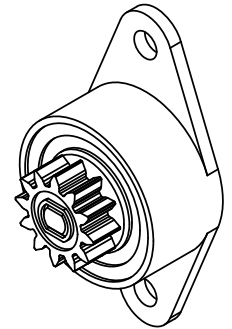
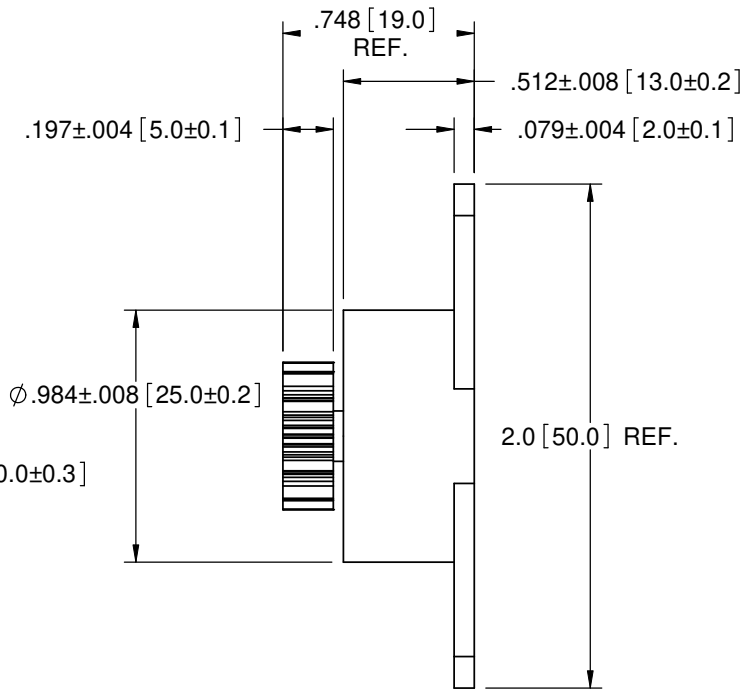
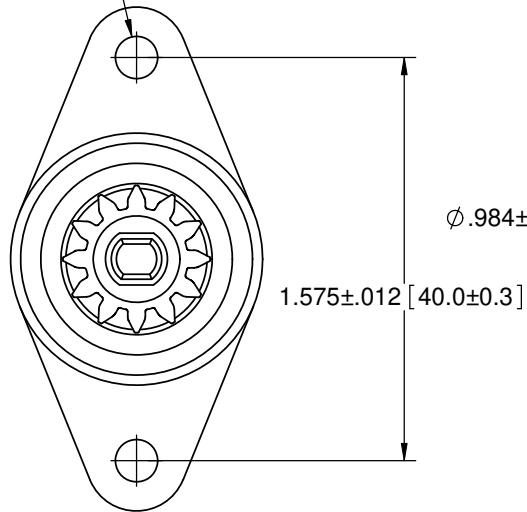

NOTES:

1. HOUSING MATERIAL: POLYCARBONATE (RMS-161).
2. COLOR: BLACK.
3. GEAR AND SHAFT MATERIAL: ACETAL (RMS-160).
4. GEAR COLOR: BLUE.
5. COMPONENTS (INSIDE HOUSING):
 - A) SILICONE OIL (RMS-209)
 - B) O-RING: SILICONE RUBBER (RMS-210)

PART NUMBER	TORQUE (gf.cm)
RFRT-D2-102-G2	1000±200
RFRT-D2-152-G2	1500±300

TITLE: TWO WAY ROTARY DAMPER							
CREATED USING SOLIDWORKS		FILE #: RFRT-D2	DWN: R.D.G.	APP: R.D.G		FINAL	
TOLERANCES UNLESS NOTED .X=±.25 .XX=±.13 ANG.=±1°		SHEET: 1 OF 1	SHEET SIZE: A	DT: 10/15/04	CHKD: S.J.	PART #	PRINT TYPE
RE: RICHCO, INC.		RICHCO, INC. ENG@RICHCO-INC.COM (773) 539-4060		SEE TABLE		CA	

REV.	DESCRIPTION	ENGR.	DATE
C	SEE CO 200131 FOR CHANGES	SK	02/20/08
B	SEE ECN #1289 FOR CHANGES	SK	02/15/07
A	RELEASED FOR PRODUCTION	SM	10/21/04