



Chipsmall Limited consists of a professional team with an average of over 10 year of expertise in the distribution of electronic components. Based in Hongkong, we have already established firm and mutual-benefit business relationships with customers from,Europe,America and south Asia,supplying obsolete and hard-to-find components to meet their specific needs.

With the principle of “Quality Parts,Customers Priority,Honest Operation,and Considerate Service”,our business mainly focus on the distribution of electronic components. Line cards we deal with include Microchip,ALPS,ROHM,Xilinx,Pulse,ON,Everlight and Freescale. Main products comprise IC,Modules,Potentiometer,IC Socket,Relay,Connector.Our parts cover such applications as commercial,industrial, and automotives areas.

We are looking forward to setting up business relationship with you and hope to provide you with the best service and solution. Let us make a better world for our industry!



Contact us

Tel: +86-755-8981 8866 Fax: +86-755-8427 6832

Email & Skype: info@chipsmall.com Web: www.chipsmall.com

Address: A1208, Overseas Decoration Building, #122 Zhenhua RD., Futian, Shenzhen, China



APPROVAL SHEET

RGCM Series – 2010(0804)- RoHS Compliance

MULTILAYER CERAMIC
COMMON MODE FILTER ARRAY

Halogens Free Product

P/N: RGCM2010090V4T

*Contents in this sheet are subject to change without prior notice.

FEATURES

1. Miniature footprint: 2.00 X 1.05 mm²
2. Multilayer Low Temperature Ceramic Co-fired Technology.
3. Reflow solderable SMD Devices
4. Wide Pass Band (Cut-Off Frequency: -3dB@ 3.0GHz Typical)
5. Characteristic Impedance (Differential) : 100 Ω(Typical)
6. High Attenuation for common mode noise
7. Special 3D layout design to minimize phase shifting

APPLICATIONS

1. High Speed Transmission Lines.
2. DVI/ LVDS/ HDMI/ S-ATA/ PCI-E/ D-Port

CONSTRUCTION

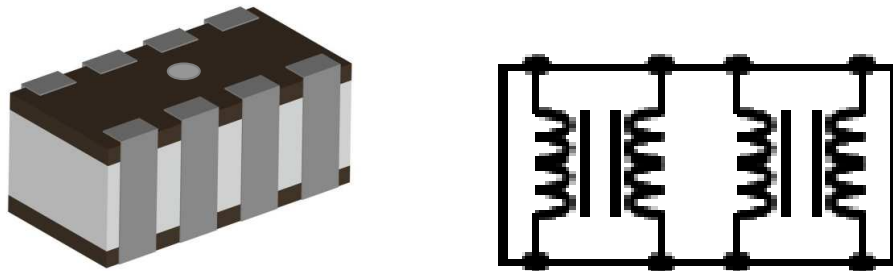

Fig 1. Outline of 2010 size Common Mode Filter and Schematics

DIMENSIONS

Figure	Symbol	Dimension
	L	2.00 ± 0.15mm
	W	1.05 ± 0.15mm
	T	0.90 ± 0.10mm
	A	0.25 ± 0.15mm
	B	0.25 ± 0.10mm
	C	0.35 ± 0.15mm
	D	0.30 ± 0.10mm
E	0.50 ± 0.15mm	

ELECTRICAL CHARACTERISTICS

RGCA2010090V4T	Specification
Cut-off Frequency	3 GHz (Typical)
Common Mode Impedance	120 ohm±25% @ 100MHz
DC Resistance	Max. 1.3 Ω
Rated Current	300 mA
Characteristic Impedance (Differential)	100 Ω(Typical)
Operating Temperature	- 40 °C ~ +85 °C

Typical Electrical Chart

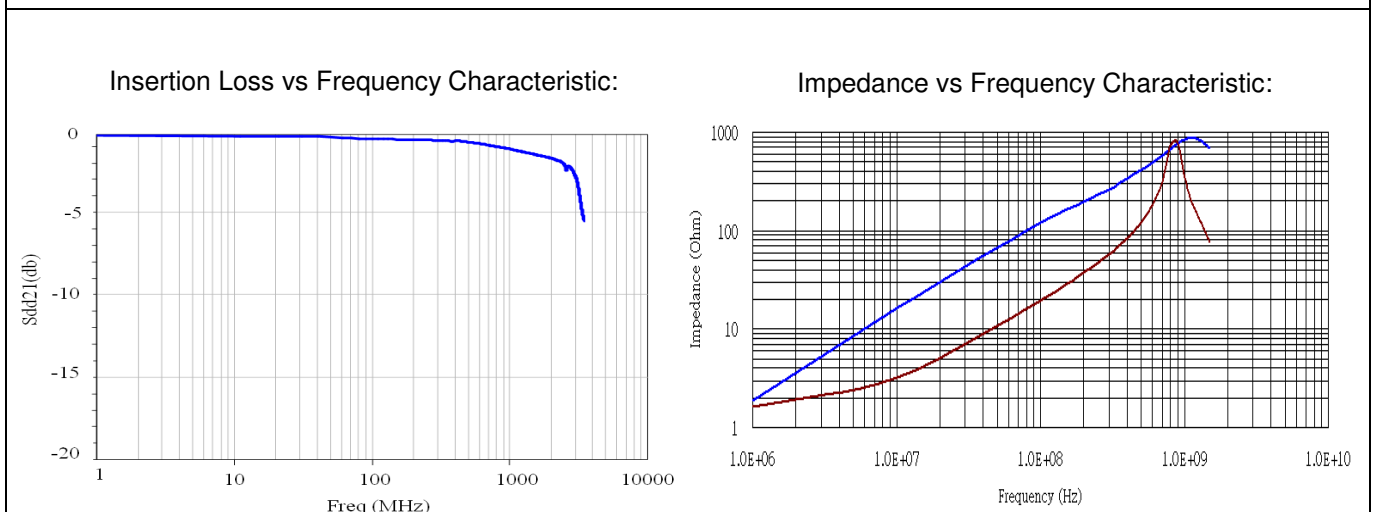

SOLDER LAND PATTERN

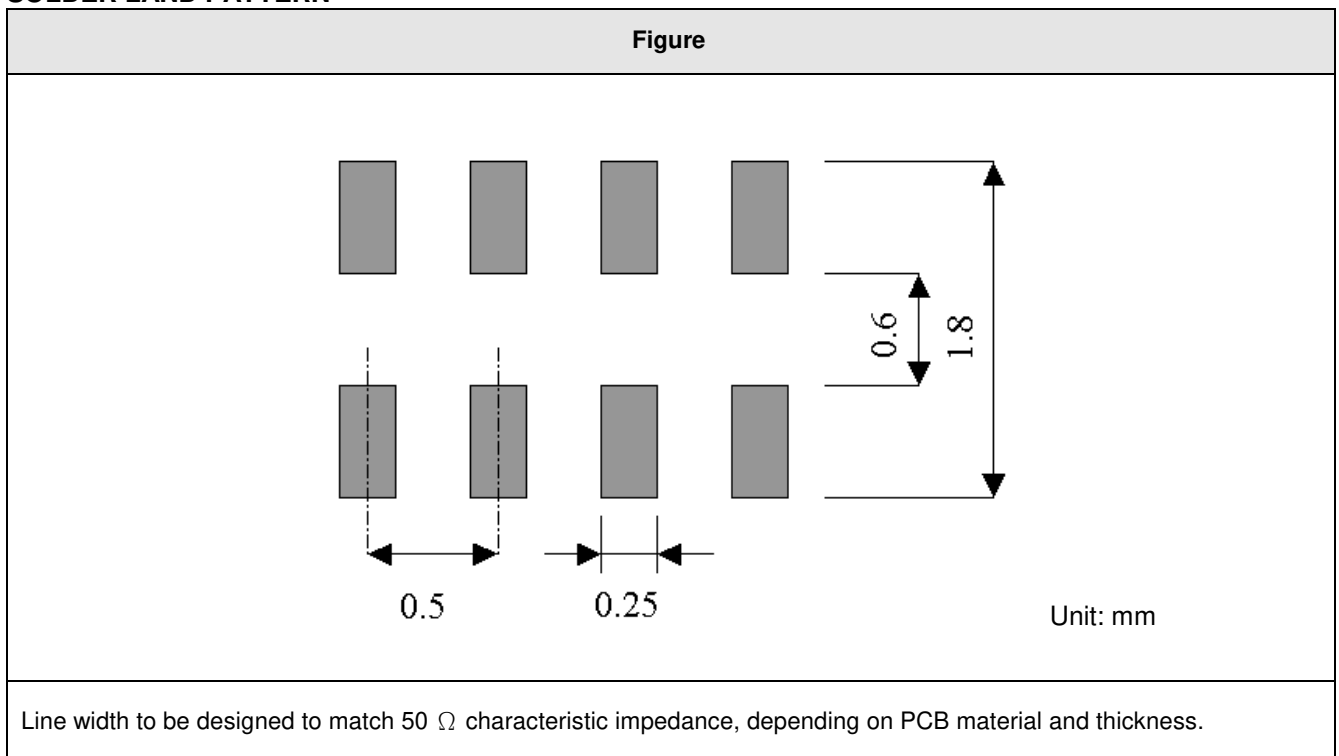

RELIABILITY TEST

Test item	Test condition / Test method	Specification
Solderability JIS C 0050-4.6 JESD22-B102D	*Solder bath temperature : $235 \pm 5^{\circ}\text{C}$ *Immersion time : 2 ± 0.5 sec *Solder : Sn3Ag0.5Cu for lead-free	At least 95% of a surface of each terminal electrode must be covered by fresh solder.
Leaching (Resistance to dissolution of metallization) IEC 60068-2-58	*Solder bath temperature : $260 \pm 5^{\circ}\text{C}$ *Leaching immersion time : 30 ± 0.5 sec *Solder : SN63A	Loss of metallization on the edges of each electrode shall not exceed 25%.
Resistance to soldering heat JIS C 0050-5.4	*Preheating temperature : $120\sim 150^{\circ}\text{C}$, 1 minute. *Solder temperature : $270\pm 5^{\circ}\text{C}$ *Immersion time : 10 ± 1 sec *Solder : Sn3Ag0.5Cu for lead-free Measurement to be made after keeping at room temperature for 24 ± 2 hrs	No mechanical damage. Samples shall satisfy electrical specification after test. Loss of metallization on the edges of each electrode shall not exceed 25%.
Drop Test JIS C 0044	*Height : 75 cm *Test Surface : Rigid surface of concrete or steel. *Times : 6 surfaces for each units ; 2 times for each side.	No mechanical damage. Samples shall satisfy electrical specification after test.
Adhesive Strength of Termination JIS C 0051- 7.4.3	*Pressurizing force : $5\text{N}(\leq 0603)$; $10\text{N}(>0603)$ *Test time : 10 ± 1 sec	No remarkable damage or removal of the termination.
Bending test JIS C 0051- 7.4.1	The middle part of substrate shall be pressurized by means of the pressurizing rod at a rate of about 1 mm/s per second until the deflection becomes 1mm/s and then pressure shall be maintained for 5 ± 1 sec. Measurement to be made after keeping at room temperature for 24 ± 2 hours	No mechanical damage. Samples shall satisfy electrical specification after test.

Temperature cycle JIS C 0025	<ol style="list-style-type: none"> 1. 30±3 minutes at -40°C±3°C, 2. 10~15 minutes at room temperature, 3. 30±3 minutes at +85°C±3°C, 4. 10~15 minutes at room temperature, Total 100 continuous cycles Measurement to be made after keeping at room temperature for 24±2 hrs	No mechanical damage. Samples shall satisfy electrical specification after test.
Vibration JIS C 0040	*Frequency : 10Hz~55Hz~10Hz(1min) *Total amplitude : 1.5mm *Test times : 6hrs.(Two hrs each in three mutually perpendicular directions)	No mechanical damage. Samples shall satisfy electrical specification after test.
High temperature JIS C 0021	*Temperature : 85°C±2°C *Test duration : 1000+24/-0 hours Measurement to be made after keeping at room temperature for 24±2 hrs	No mechanical damage. Samples shall satisfy electrical specification after test.
Humidity (steady conditions) JIS C 0022	*Humidity : 90% to 95% R.H. *Temperature : 40±2°C *Time : 1000+24/-0 hrs. Measurement to be made after keeping at room temperature for 24±2 hrs ※ 500hrs measuring the first data then 1000hrs data	No mechanical damage. Samples shall satisfy electrical specification after test.
Low temperature JIS C 0020	*Temperature : -40°C±2°C *Test duration : 1000+24/-0 hours Measurement to be made after keeping at room temperature for 24±2 hrs	No mechanical damage. Samples shall satisfy electrical specification after test.

Typical examples of soldering processes that provide reliable joints without any damage are given in Fig 2,

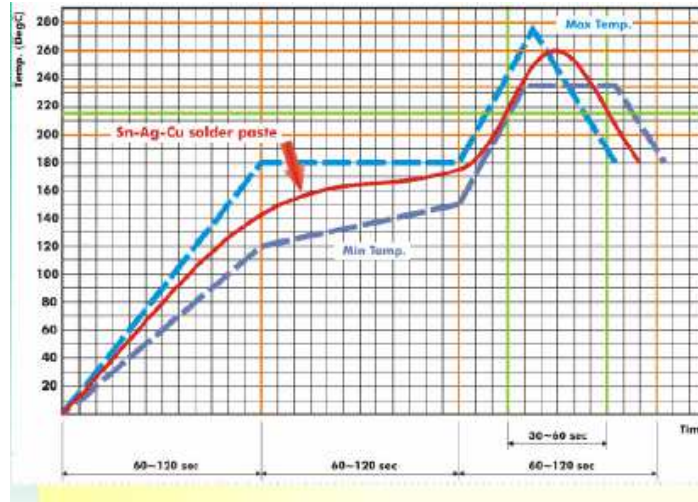

Fig 2. Infrared soldering profile

ORDERING CODE

RG Walsin RF device	CMA Product Code CMA : Common Mode Filter Array	201009 Dimension code 201009 = Width 20, Length 10, Thickness 9	0 Unit of dimension 0: 0.1 mm 1: 1.0 mm	V Application V: High Speed Transmission Lines HDMI/ LVDS/ DVI/ PCI-E/ Display Port/ SATA	4 Specification Code from 0 ~ 9 dependent on different electrical specification	T Packing T: Reeled
----------------------------------	--	---	--	--	---	----------------------------------

Minimum Ordering Quantity: 2000 pcs per reel.

PACKAGING

Paper Tape specifications (unit :mm)

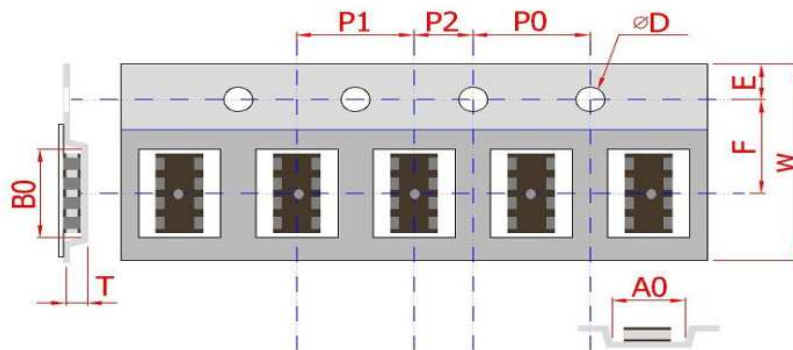

Index	A ₀	B ₀	ΦD	T	W
Dimension(mm)	1.30±0.10	2.25±0.10	1.00±0.10	1.10±0.10	8.00±0.20
Index	E	F	P ₀	P ₁	P ₂
Dimension(mm)	1.75±0.10	3.50±0.05	4.00±0.10	4.00±0.10	2.00±0.05

Reel dimensions

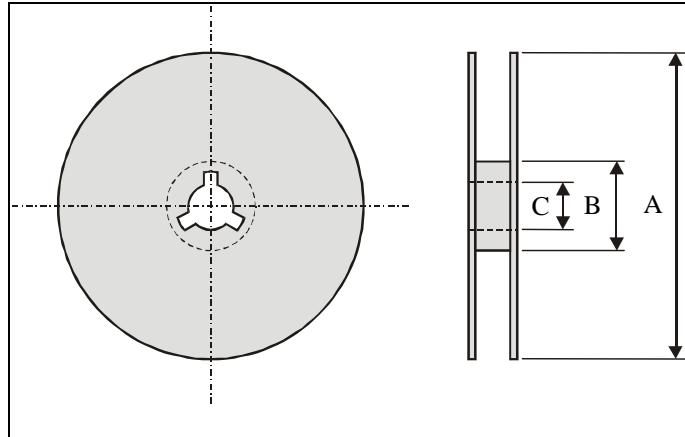

Index	A	B	C
Dimension (mm)	Φ178.0	Φ60.0	Φ13.0

Taping Quantity:2000 pieces per 7" reel

CAUTION OF HANDLING

Limitation of Applications

Please contact us before using our products for the applications listed below which require especially high reliability for the prevention of defects, which might directly cause damage to the third party's life, body or property.

- (1) Aircraft equipment
- (2) Aerospace equipment
- (3) Undersea equipment
- (4) Medical equipment
- (5) Disaster prevention / crime prevention equipment
- (6) Traffic signal equipment
- (7) Transportation equipment (vehicles, trains, ships, etc.)
- (8) Applications of similar complexity and /or reliability requirements to the applications listed in the above.

Storage condition

- (1) Products in N₂ gas sealed bag should be used in 6 months from the day of WALSIN outgoing inspection and 1 month after open, which can be confirmed the quality.



- (2) Storage environment condition.

- Products should be storage in the warehouse on the following conditions.
- Temperature : -10 to +40°C
- Humidity : 30 to 70% relative humidity
- Don't keep products in corrosive gases such as sulfur. Chlorine gas or acid or it may cause oxidization of electrode, resulting in poor solderability.
- Products should be storage on the palette for the prevention of the influence from humidity, dust and son on.
- Products should be storage in the warehouse without heat shock, vibration, direct sunlight and so on.
- Products should be storage under the airtight packaged condition.