



Chipsmall Limited consists of a professional team with an average of over 10 year of expertise in the distribution of electronic components. Based in Hongkong, we have already established firm and mutual-benefit business relationships with customers from,Europe,America and south Asia,supplying obsolete and hard-to-find components to meet their specific needs.

With the principle of “Quality Parts,Customers Priority,Honest Operation,and Considerate Service”,our business mainly focus on the distribution of electronic components. Line cards we deal with include Microchip,ALPS,ROHM,Xilinx,Pulse,ON,Everlight and Freescale. Main products comprise IC,Modules,Potentiometer,IC Socket,Relay,Connector.Our parts cover such applications as commercial,industrial, and automotives areas.

We are looking forward to setting up business relationship with you and hope to provide you with the best service and solution. Let us make a better world for our industry!



Contact us

Tel: +86-755-8981 8866 Fax: +86-755-8427 6832

Email & Skype: info@chipsmall.com Web: www.chipsmall.com

Address: A1208, Overseas Decoration Building, #122 Zhenhua RD., Futian, Shenzhen, China



Photon Detection Solutions

For Consumer, Health, Safety
and Security Applications - 3.0

Photon detection for tomorrow's cutting-edge applications.

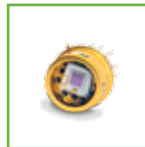

EXCELITAS
TECHNOLOGIES®

Making Your World Smarter, Healthier, Safer & More Secure.

At Excelitas, we're sensing what you need for a healthier, safer and innovative tomorrow. From Photon Counting Modules to Silicon Detectors, InGaAs Detectors, smoke and particle detection modules and Pulsed Laser Diodes, our Photon Detection technologies are addressing your high-performance and high-volume applications. We have the detection technologies and capabilities to enhance and accelerate your OEM designs. You can depend on our five world-class design, manufacturing and R&D facilities including: Montreal, Canada; Wiesbaden, Germany; Singapore; Manila, Philippines; and Batam, Indonesia.

Our Photon Detection Solutions contribute to enabling:

Next generation smart consumer electronics.

- LIDAR for autonomous vehicles and drones
- Vital sign monitoring sensors for wearables
- Gesture recognition

Longer, healthier lives.

- Luminescence and fluorescence for analytical and clinical diagnostics
- Photon counting, particle sizing
- PET, CT, and MRI scanning

Enhanced safety and security.

- X-ray scanning of luggage, cargo and food
- Laser range finding – industrial and consumer
- Smoke & particle detection
- Safety curtains

SECTION 1 • AVALANCHE PHOTODIODES

- Silicon APDs
- InGaAs APDs

SECTION 2 • PIN PHOTODIODES

- Silicon PIN Photodiodes
- InGaAs PIN Photodiodes

SECTION 3 • OPTICAL RECEIVERS

- Silicon Optical Receivers
- InGaAs Optical Receivers

SECTION 4 • LOW LIGHT LEVEL (L³D) DETECTORS & MODULES

- Single Photon Counting Modules (SPCM)
- Lynx SiPM Module
- Helix APD Module
- Coherent InGaAs PIN Balanced Receiver Module

SECTION 5 • PULSED LASER DIODES

- 905 nm Pulsed Laser Diodes

SECTION 6 • SMOKE DETECTION MODULES

- Components for Smoke Detection

SECTION 7 • SILICON PHOTODIODE ARRAYS

- VTA Series

SECTION 8 • SILICON PIN PHOTODIODES

- Blue-enhanced VTB Series
- High-Speed VTP Series
- Industry Standard VTD Series

SECTION 9 • INFRARED EMITTING DIODES

- 880 nm IREDS
- 940 nm IREDS

SECTION 10 • SILICON PHOTOTRANSISTORS

- VTT Series

SECTION 11 • CCD

- CCD Linear Sensors
- CCD Linear Cameras

SECTION 1	
Avalanche Photodiodes	4
SECTION 2	
PIN Photodiodes	11
SECTION 3	
Optical Receivers	13
SECTION 4	
Low Light Level (L ³ D) Detectors & Modules	15
SECTION 5	
Pulsed Laser Diodes	19
SECTION 6	
Smoke Detection Modules	22
SECTION 7	
Silicon Photodiode Arrays	24
SECTION 8	
Silicon PIN Photodiodes	26
SECTION 9	
Infrared Emitting Diodes	34
SECTION 10	
Silicon Phototransistors	36
SECTION 11	
CCD	39

Avalanche Photodiodes

For Industrial & Analytical Applications

AVALANCHE PHOTODIODES ■

Avalanche Photodiodes
Silicon APDs



Avalanche Photodiodes – Silicon APDs

Applications

- Laser range finder
- Scanning video imager
- Confocal microscope
- Free space communication
- Spectrophotometers
- Fluorescence detection
- Luminometer
- DNA sequencer
- Particle sizing

Features and Benefits

- Low noise
- High gain
- High quantum efficiency
- Built-in TE-cooler option
- Various optical input options
- Customization available upon request

Product Description

These rear entry "reach-through" silicon APDs offer the best compromise in terms of cost and performance for applications requiring high speed and low noise photon detection from 400 nm up to 1100 nm. They feature low noise, high quantum efficiency and high gain while maintaining reasonably low operating voltage. The active area varies from 0.5 mm to 3 mm to accommodate a large variety of applications.

The "S" series of the C30902 family of APDs can be used in either their normal linear mode ($V_R < V_{BR}$) or for photon counter in the Geiger mode ($V_R > V_{BR}$). This series is particularly well-suited for ultra-sensitive photon measurements in biomedical and analytical instruments. Precise temperature control can be achieved with a thermo-electric cooler which can be used to improve noise and responsivity or to maintain constant responsivity over a wide range of ambient temperature.

These APDs can also be incorporated into a hermetically-sealed TO-8 package with ultra-low noise preamplifier (C30659 series APD receivers) and thermo-electric cooler (LLAM series receivers) for optimum signal to noise performance.

Technical Specification

Avalanche Photodiodes – Silicon APDs

Unit	Active Diameter mm	Capacitance pF	Rise/Fall Time ns	Dark Current nA	Breakdown Voltage min V	Breakdown Voltage max V	Temp. Coefficient V/°C	Typical Gain	Responsivity 830 nm A/W	Responsivity 900 nm A/W	Responsivity 1060 nm A/W	NEP fW/√Hz	Package
C30817EH	0.8	2	2	50	300	475	2.2	120	-	75	-	1	TO-5
C30884E	0.8	4	1	100	190	290	1.1	100	-	63	8	13	TO-5
C30902BH	0.5	1.6	0.5	15	185	265	0.7	150	77	60	-	3	Ball lens TO-18
C30902BSTH	0.5	1.6	0.5	15	185	265	0.7	150	77	60	-	3	ST receptacle
C30902EH	0.5	1.6	0.5	15	185	265	0.7	150	77	60	-	3	TO-18, flat window
C30902EH-2	0.5	1.6	0.5	15	185	265	0.7	150	77	60	-	3	TO-18, built-in 905 nm filter
C30902SH	0.5	1.6	0.5	15	185	265	0.7	250	128	108	-	0.9	TO-18, flat window
C30902SH-2	0.5	1.6	0.5	15	185	265	0.7	250	128	108	-	0.9	TO-18, built-in 905 nm filter
C30916EH	1.5	3	3	100	315	490	2.2	80	-	50	12	20	TO-5
C30921EH	0.25	1.6	0.5	15	185	265	0.7	150	77	60	-	3	TO-18, flat window
C30921SH	0.25	1.6	0.5	15	185	265	0.7	250	128	108	-	0.9	TO-18, light pipe
C30954EH	0.8	2	2	50	300	475	2.4	120	-	75	36	13	TO-5
C30955EH	1.5	3	2	100	315	490	2.4	100	-	70	34	14	TO-5
C30956EH	3	10	2	100	325	500	2.4	75	-	45	25	25	TO-8

Product Table

Silicon APD – TE-Cooled

Unit	Active Diameter	Active Area	Total Capacitance	Rise/Fall Time	Dark Current	Breakdown Voltage min	Breakdown Voltage max	Temperature Coefficient	Typical Gain	Responsivity 830 nm	Responsivity 900 nm	Responsivity 1060 nm	Noise Current	Package
	mm	mm ²	pF	ns	nA	V	V			A/W	A/W	A/W	pA/sqrt(Hz)	
C30902SH-TC	0.5	0.2	1.6	0.5	2	225	-	0.7	250	128	108	-	0.04	TO-8 flange
C30902SH-DTC	0.5	0.2	1.6	0.5	1	225	-	0.7	250	128	108	-	0.02	TO-8 flange
C30954E-TC	0.8	0.5	2	2	50	300	475	2.4	120	-	75	-	0.2	TO-8 flange
C30955E-TC	1.5	1.8	3	2	100	315	490	2.4	100	-	70	-	0.2	TO-8 flange
C30956E-TC	3	7	10	2	100	325	500	2.4	75	-	45	-	0.2	TO-8 flange

TC stands for single stage cooler, operating temperature 0° C
DTC stands for double stage cooler, operating temperature -20° C

Graph 1

Typical Spectral Responsivity @ 22° C

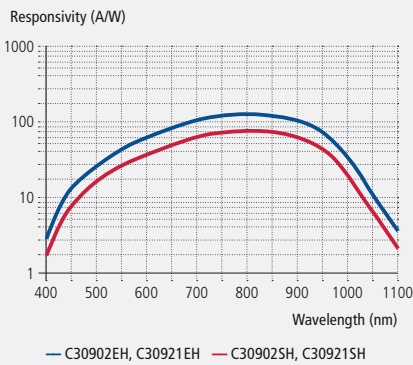

Figure 1

Package Drawing – TO-8 Flange

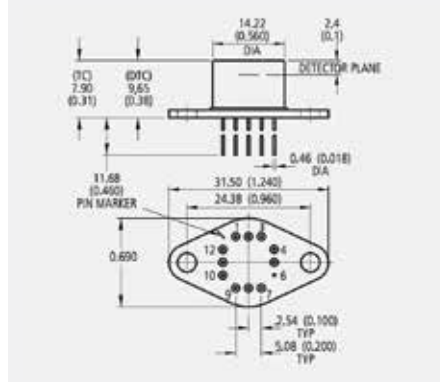

Figure 2

Typical TO-5 Package*

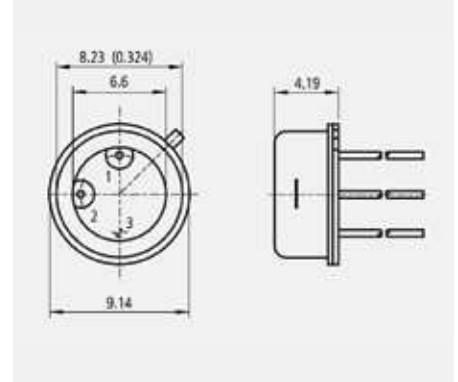

Figure 3

Typical TO-8 Package*

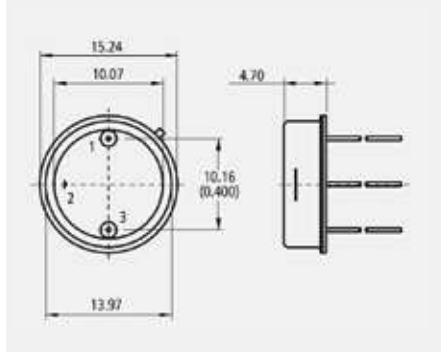
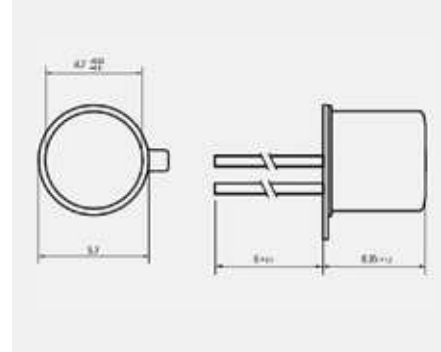

Figure 4

Typical TO-18 Package*



*Note: Package dimensions for indication only. Exact package dimensions can be found on products datasheets.

Avalanche Photodiodes For Analytical Applications

AVALANCHE PHOTODIODES ■

Avalanche Photodiodes Si APD Arrays

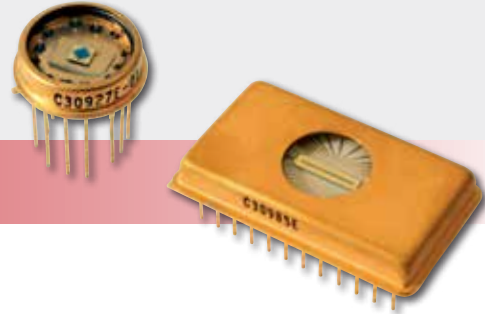

Avalanche Photodiodes – Si APD Arrays

Applications

- Spectroscopy
- Particle detection
- Spot tracking and alignment systems
- Adaptive optics
- LIDAR (Light Detection And Ranging)

Features and Benefits

- High quantum efficiency
- Hermetically-sealed packages
- Monolithic chip with minimal dead space between elements
- Specific tailored wavelength response
- RoHS compliant
- Customization available upon request

Product Description

The C30927 series of quadrant Si Avalanche Photodiode and the C30985E multi-element APD array utilize the double-diffused "reach-through" structure. This structure provides ultra high sensitivity at 400-1000 nm.

The C30927 quadrant structure has a common avalanche junction, with separation of the quadrants achieved by segmentation of the light entry p+ surface opposite the junction. With this design, there is no dead space between the elements and therefore no loss of response at boresight.

The C30927EH-01, -02 and -03 are optimized for use at wavelengths of 1060, 900, and 800 nm respectively. Each device type will provide high responsivity and excellent performance when operated within about 50 nm of the specified wavelength.

The C30985E is a 25 element monolithic linear APD array having a high inter-electrode resistance with a 75 μm dead space between the elements. Packages have a common ground and bias with a separate lead for each element output.

Product Table

Avalanche Photodiodes – Si APD Arrays

Part Number	Number of Elements	Photo Sensitive Diameter	Responsivity	Dark Current per Element	Spectral Noise Current	Capacitance @ 100 KHz	Response Time	NEP	
								FW/Hz	V
C30927EH-01	4	1.5	15(@ 1060 nm)	25	0.5	1	3	33(@ 1060 nm)	275-425
C30927EH-02	4	1.5	62(@ 900 nm)	25	0.5	1	3	16(@ 900 nm)	275-425
C30927EH-03	4	1.5	55(@ 800 nm)	25	0.5	1	3	9(@ 800 nm)	275-425
C30985E	25	0.3	31(@ 900 nm)	1	0.1	0.5	2	3(@ 900 nm)	250-425

Figure 1

Package Drawing – C30927 Series

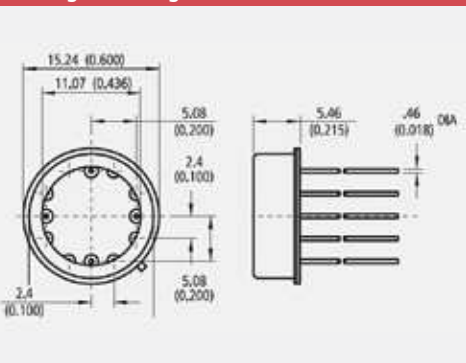
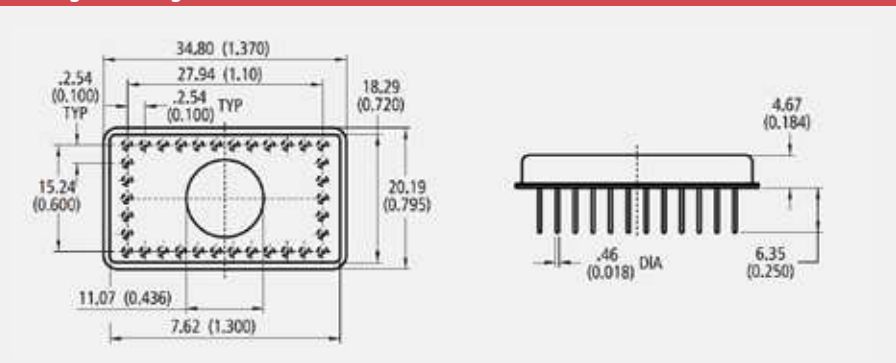

Figure 2

Package Drawing – C30985E



Avalanche Photodiodes

For Analytical Applications

AVALANCHE PHOTODIODES ■

Avalanche Photodiodes
1060 nm NIR Enhanced Si APDs

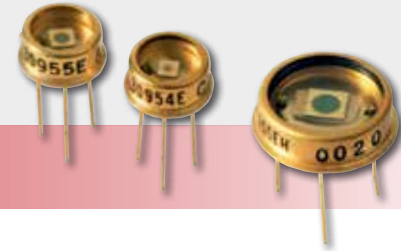

1060 nm NIR Enhanced Si APDs

Applications

- Range finding
- LIDAR (Light Detection And Ranging)
- YAG laser detection

Features and Benefits

- High quantum efficiency at 1060 nm
- Fast response time
- Wide operating temperature range
- Low capacitance
- Hermetically-sealed packages
- RoHS compliant
- Customization available upon request

Product Description

The C30954EH, C30955EH, and C30956EH are general purpose silicon avalanche photodiodes made using a double-diffused "reach-through" structure. The design of these photodiodes are such that their long wave response (i.e. >900 nm) has been enhanced without introducing any undesirable properties.

These APDs have quantum efficiency of up to 40% at 1060 nm. At the same time, the diodes retain the low noise, low capacitance, and fast rise and fall times characteristics.

To help simplify many design needs, these APDs are also available in Excelitas' high-performance hybrid preamplifier module type C30659 series, as well as the preamplifier and TE cooler incorporated module type LLAM series. In addition, these APDs are also available with built-in thermo-electric cooler for easier temperature control. Please refer to the respective sections in this catalog.

Graph 1

Spectral Responsivity Characteristics

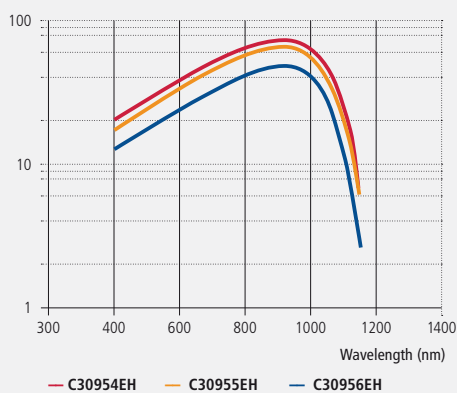

Product Table

Si APDs – NIR Enhanced

Part Number	Photo Sensitive Diameter	Respon-sivity @ 1060 nm	Dark Current	Spectral Noise Current	Capacitance @ 100 KHz	Response Time	NEP @ 1060 nm	Vop Range
Unit	mm	A/W	nA	pA/√Hz	pF	ns	fW/√Hz	V
C30954EH	0.8	36	50	0.5	2	2	14	275 - 425
C30955EH	1.5	34	100	0.5	3	2	15	275 - 425
C30956EH	3.0	25	100	0.5	10	2	20	275 - 425

Figure 1

Package Drawing – C30954EH, C30955EH

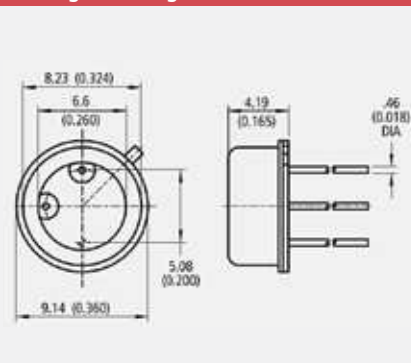
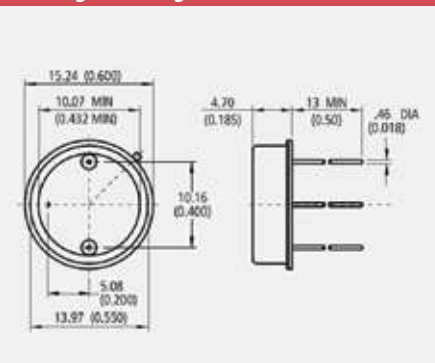

Figure 2

Package Drawing – C30956EH



Avalanche Photodiode

For High Energy Radiation Detection Applications, Molecular Imaging

AVALANCHE PHOTODIODES ■

Large Area Si-APDs – UV-Enhanced APDs

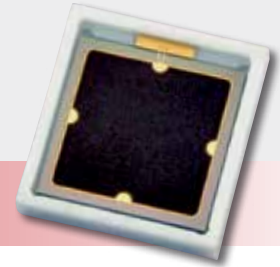

Large Area Si-APDs – UV-Enhanced APDs

Applications

- Nuclear medicine
- Fluorescence detection
- High energy physics
- Medical imaging
- Radiation detection
- Particle physics
- Instrumentation
- Environmental monitoring

Features and Benefits

- High quantum efficiency
- Low dark currents
- Easy coupling to scintillator crystals
- Immunity to electromagnetic fields
- Custom packaging available
- Excellent timing resolution
- RoHS compliant
- Customization available upon request

Product Description

The C30739ECERH Silicon Avalanche Photodiode (APD) is intended for use in a wide variety of broadband low light level applications covering the spectral range from below 400 to over 700 nanometers. It has low noise, low capacitance and high gain. It is designed to have an enhanced short wavelength sensitivity, with quantum efficiency of 60 % at 430 nm.

The standard ceramic carrier package allows for easy handling and coupling to scintillating crystals such as LSO and BGO. Combined with the superior short wavelength responsivity, it makes this APD ideal in demanding applications such as Positron Emission Tomography (PET).

The C30626FH and C30703FH series are large area Si APDs in flat pack packages for either direct detection or easy coupling to scintillator crystals.

The C30626 uses a standard reach through structure and has peak detection at about 900 nm. The C30703 is enhanced for blue wavelength response and has peak quantum efficiency at ~ 530 nm. These APDs are packaged in a square flat pack with or without windows or on ceramics. The no-window devices can detect direct radiation of X-rays and electrons at the energies listed, and the windowed packages are best for easy scintillator coupling.

Graph 1

Quantum Efficiency vs. Wavelength

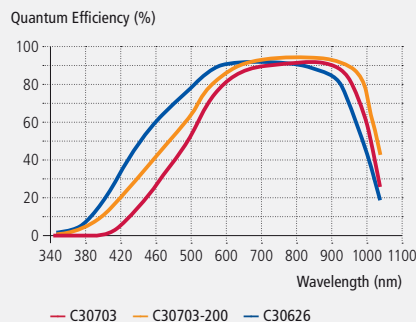

Graph 2

Quantum Efficiency vs. Wavelength

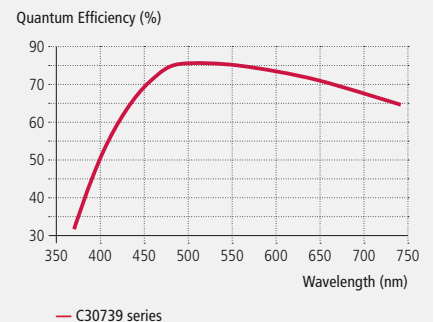

Product Table

Large Area Si-APDs – UV-Enhanced APDs

Part Number	Photo Sensitive Diameter	Responsivity	Dark Current	Spectral Noise Current	Capacitance @ 100 KHz	Response Time	NEP	Vop Range
Unit	mm	A/W	nA	pA/√Hz	pF	ns	fW/√Hz	V
C30626FH	5 x 5	22 (@900 nm)	250	0.5	30	5	23(@900 nm)	275 - 425
C30703FH	10 x 10	16 (@530 nm)	10	0.7	100	5	40(@530 nm)	275 - 425
C30703FH-200	10 x 10	16 (@530 nm)	10	0.7	60	5	40(@530 nm)	275 - 425
C30739ECERH	5.6 x 5.6	20 (@430 nm)	50	1.4	60	2	-	275 - 425
C30739ECERH-2	5.6 x 5.6	52(@430 nm)	50	2	60	2	-	275 - 425

Avalanche Photodiodes

For Range Finding Applications

AVALANCHE PHOTODIODES ■

Right: TO-C30737PH Series
T-1¼ (TO-like) Through-Hole
Package (4.9 mm Diameter)

Left: C30737LH Series
Leadless Ceramic Carrier
Package (3 x 3 mm²)

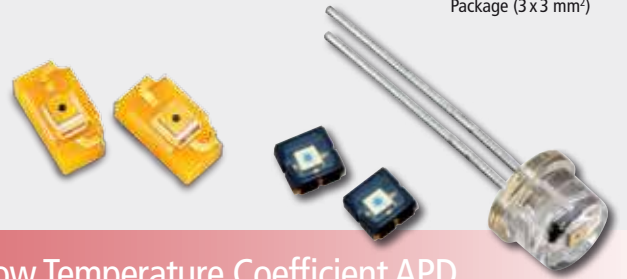

C30737 High Speed, Low Voltage APD – C30724 Low Temperature Coefficient APD

Applications

- Laser range finding for 600 to 950 nm range
- Optical communication
- Analytical Instrumentation

Features and Benefits

- Optimized versions for peak responsivity at 900 nm or high bandwidth operation
- Standard versions with 500 and 230 µm active diameter
- Various package types: hermetic TO, plastic TO, SMD top-and side-looking
- High gain at low bias voltage
- Low breakdown voltage
- Fast response, $t_R \sim 300$ ps
- Low noise, in ~ 0.2 pA/√Hz
- RoHS compliant
- Customization available upon request

Product Description

The Excelitas C30737 series silicon APDs provide high responsivity between 500 nm and 1000 nm as well as extremely fast rise times at all wavelengths, with a frequency response above 1 GHz for bandwidth-optimised versions. The C30724, as a low gain APD, can be operated at a fixed voltage without the need for temperature compensation.

Standard versions of the 737 are available in three active area sizes: 0.23, 0.3 and 0.5 mm diameter. They are offered in the traditional hermetic TO housing ("E"), in cost-effective plastic through-hole T-1¼ (TO-like, "P") packages, in leadless ceramic carrier (LCC, "L") top-looking package and laminated leadless ceramic (LLC, "C") side-looking package for surface mount use. All listed varieties are ideally suited for high-volume, low cost applications.

Customization of these APDs is offered to meet your design challenges. Operating voltage selection and binning or specific wavelength filtering options are among many of the application-specific solutions available.

Product Table

C30737 Epitaxial Silicon APD – C30724 Low-Gain APD

Part Number	Package	Optical Bandpass Filter	Active Area Diam.	Peak Sensitivity Wavelength	Breakdown Voltage		Temp. Coeff. Of V_{OP} , for Constant M	Gain@ λ_{peak}	Responsivity @ λ_{peak}	Total Dark Current (Bulk + Surface)		Noise Current, (f = 10 kHz, $\Delta f = 1$ Hz)	Capacitance	Rise & Fall Time, (RL = 50 Ω , 10% - 90% - 10% Points)
		design	design	typ	min	max	typ	typ	typ	typ	typ		typ	
Unit		nm	μ m	λ_{peak}	V_{BR}	V_{BR}	V/°C	M	M	I_D	I_D	pA/√Hz	C_D	ns
C30737EH-230-80	TO	-	230	800	120	200	0.5	100	50	0.05	0.5	0.1	1.0	0.2
C30737PH-230-80	T-1¼	-	230	800	120	200	0.5	100	50	0.05	0.5	0.1	1.0	0.2
C30737LH-230-80	LCC	-	230	800	120	200	0.5	100	50	0.05	0.5	0.1	1.0	0.2
C30737LH-230-81	LCC	635	230	635	120	200	0.5	100	35	0.05	0.5	0.1	1.0	0.2
C30737LH-230-83	LCC	650	230	650	120	200	0.5	100	35	0.05	0.5	0.1	1.0	0.2
C30737CH-230-80	LLC	-	230	800	120	200	0.5	100	50	0.05	0.5	0.1	1.0	0.2
For the remaining 737 family APDs only a generic package and filter part number will be shown, just to show the different APD chip characteristics														
C30737XH-300-7X	LLC, LCC	635, 650	300	800	110	160	-	100	50	0.1	1	0.1	0.7	0.5
C30737XH-500-8X	all	635, 650	500	800	120	200	0.5	100	50	0.1	1	0.1	2.0	0.9
C30737XH-230-9X	all	905	230	900	180	260	1.3	100	60	0.05	0.5	0.1	0.6	0.9
C30737XH-500-9X	all	905	500	900	180	260	1.3	100	60	0.1	1	0.1	1.0	0.9
C30724EH	TO	-	500	920	-	350	-	15	8.5	20	40	0.1	1.0	5
C30724PH	T-1¼	-	500	920	-	350	-	15	8.5	20	40	0.1	1.0	5

Electrical Characteristics at $T_{Ambient} = 22$ °C; at operating voltage, V_{OP}

Avalanche Photodiodes

For Industrial & Analytical Applications

AVALANCHE PHOTODIODES ■

Avalanche Photodiodes
Silicon InGaAs APDs



Avalanche Photodiodes – InGaAs APDs

Applications

- Laser range finder
- Scanning video imager
- Confocal microscope
- Free space communication
- Spectrophotometers
- Fluorescence detection
- Luminometer
- DNA sequencer
- Particle sizing

Features and Benefits

- Low noise
- High gain
- High quantum efficiency
- Built-in TE-cooler option
- Various optical input options
- Customization available upon request

Product Description

The C30644, C30645 and C30662 Series APDs are high speed, large area InGaAs/InP avalanche photodiodes. These devices provide large quantum efficiency, (QE), high responsivity and low noise in the spectral range between 1100 nm and 1700 nm, with standard active areas up to 200 μm in diameter. They are optimized for use at a wavelength of 1550 nm, ideally suitable for use in eye-safe laser range finding systems.

These APDs are supplied in a hermetically-sealed TO-18 package, with the chip mounted close to the window to allow easy interfacing with the optical system, or on a ceramic carrier. The C30645 and C30662 series APD are offered in the C30659 series of APD receivers with low noise transimpedance amplifier, as well as built-in thermo-electric cooler (the LLAM series). For these modules, refer to page 13 of this catalogue. Other custom package are also available on request.

Product Table

InGaAs APD

Unit	Active Diameter μm	Capacitance pF	Bw MHz	Dark Current nA	Breakdown Voltage min V	Breakdown Voltage max V	Temperature Coefficient V/ $^{\circ}\text{C}$	Typical Gain	Responsivity 1550 nm A/W	NEP fW/sqrt(Hz)	Package
C30662EH	200	2.5	800	70	40	90	0.14	10	9.3	100	TO-18
C30662EH-1	200	2.5	800	70	40	90	0.14	10	9.3	100	TO-18
C30662ECERH	200	2.5	800	70	40	90	0.14	10	9.3	100	Ceramic carrier
C30662ECERH-1	200	2.5	800	70	40	90	0.14	10	9.3	100	Ceramic carrier
C30645EH	80	1.25	1000	35	40	90	0.14	10	9.3	25	TO-18
C30645ECERH	80	1.25	1000	35	40	90	0.14	10	9.3	25	Ceramic carrier
C30644EH	50	0.6	2000	25	40	90	0.14	10	9.3	15	TO-18
C30644ECERH	50	0.6	2000	25	40	90	0.14	10	9.3	15	Ceramic carrier

NOTE: The "-1" version of the C30662 series have a Vbr-Vop of >4V.

PIN Photodiodes

For Industrial Applications

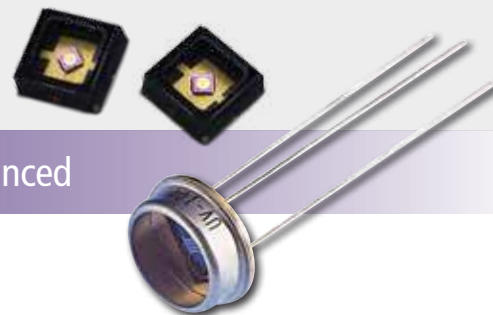

InGaAs and Si PIN Diodes – Quadrant Detectors – UV-Enhanced

Applications

- Telecom
- Instrumentation
- Photometry
- Laser power monitoring
- Fiber optic test equipment
- High speed switching
- Spot tracking
- Laser range finders
- Missile guidance
- Laser warning system

Features and Benefits

- High speed
- High responsivity
- Hermetically-sealed
- Large area available
- High shunt resistance, low dark current
- Customization available upon request

Product Description

Silicon PIN photodiodes are available in a wide variety of active areas to accommodate a large range of applications. The PIN structure allows high quantum efficiency and fast response for detection of photons in the 400 nm to 1100 nm range.

The YAG series offers an exceptional 0.4 A/W at 1060 nm by using a thick silicon material. Designed with a guard ring to collect current generated outside of the active area, they are the detectors of choice when the entire chip is illuminated by reducing unwanted carriers responsible for noise. Precise beam positioning can be achieved by using our quadrant detectors. They are designed with 4 pie-shaped quadrant sections created via the doping process, thus reducing the "dead" space between each quadrant to almost zero. Each quadrant is then connected to an isolated lead.

The C30741 provides fast response and good quantum efficiency in the spectral range between 300 nm to 1100 nm. Designed for high-speed, high-volume production and cost-sensitive applications, these photodiodes are offered in plastic TO-style packages with a visible blocking filter option.

Our UV series are high quality Si PIN photodiodes in hermetically-sealed TO packages designed for the 220 nm to 1100 nm wavelength region with enhanced operation in the UV range. Low noise detection is achieved by operating the UV series in photovoltaic mode (0 V bias).

The InGaAs PIN detectors provide high quantum efficiency from 800 nm to 1700 nm. They feature low capacitance for extended bandwidth, high resistance for high sensitivity, high linearity, and uniformity within 2 % across the detector active area.

Product Table

InGaAs PIN, High Speed, Peak Wavelength at 1550 nm

Unit	Active Diameter	Responsivity Peak	Capacitance	Bw	Dark Current	Breakdown Voltage	Operating Voltage	Package
	µm	A/W	pF	GHz	nA	V	V	
C30617BH	100	0.95	0.8	3.5	<1	100	5	TO-18, ball lens
C30617BFCH	100	0.95	0.8	3.5	<1	100	5	TO-18, FC receptacle
C30617BSCH	100	0.95	0.8	3.5	<1	100	5	TO-18, SC receptacle
C30617BQC-04-XX	100	0.95	0.8	3.5	<1	100	5	TO-18 ST receptacle
C30617ECERH	100	0.95	0.6	3.5	<1	100	5	Ceramic carrier
C30617L-100	100	0.95	0.6	3.5	<1	100	5	SMT
C30618BFCH	350	0.95	4	0.75	1	100	5	TO-18, FC receptacle
C30618GH	350	0.95	4	0.75	1	100	5	TO-18
C30618ECERH	350	0.95	4	0.75	1	100	5	Ceramic carrier
C30618L-350	350	0.95	4	0.75	1	100	5	SMT

Product Table

InGaAs PIN, Large Area, Peak Wavelength at 1550 nm

Unit	Active Diameter mm	Responsivity Peak A/W	Capacitance pF	Shunt Resistance Mega Ohm	B _w MHz	Dark Current nA	Breakdown Voltage V	Operating Voltage V	Package
C30619GH	0.5	0.95	40	250	75	5	80	0-10	TO-18
C30641EH-TC	1	0.95	8	50	350	1	80	0-5	TO-8, flange, TE-cooled
C30641EH-DTC	1	0.95	40	50	75	5	80	0-5	TO-8, flange, dual TE
C30641GH	1	0.95	40	50	75	5	80	0-5	TO-18
C30642GH	2	0.95	150	25	20	10	50	0-5	TO-5
C30665GH	3	0.95	200	10	3	25	50	0-5	TO-5
C30723GH	5	0.95	950	5	3	-	50	0-5	TO-5

Product Table

Silicon PIN

Unit	Active Diameter mm	Active Area mm ²	Responsivity Peak A/W	Peak Wavelength nm	Capacitance pF	Rise/Fall Time ns	Dark Current nA	Shunt Resistance MΩ	Breakdown Voltage V	Operating Voltage V	Package
C30741PH-15S	1.5 x 1.5	2.25	0.47	800	11	2	0.05	-	300	10	Plastic T-1¾ through-hole
C30741PFH-15S	1.5 x 1.5	2.25	0.47	800	11	2	0.05	-	300	10	T-1¾ visible blocking
C30807EH	1	0.8	0.6	900	2.5	5	10	-	>100	45	TO-18
C30808EH	2.5	5	0.6	900	6	8	30	-	>100	45	TO-5
C30822EH	5	20	0.6	900	17	10	50	-	>100	45	TO-8
C30809EH	8	50	0.6	900	35	15	70	-	>100	45	TO-8
C30810EH	11	100	0.6	900	70	20	300	-	>100	45	TO-36
C30971EH	0.5	0.2	0.5	830	1.6	0.5	10	-	>200	100	TO-18
FFD-100H	2.5	5.1	0.6	850	8.5	3.5	5	-	>125	15	TO-5
FFD-200H	5	20	0.6	850	30	5	10	-	>125	15	3 pin, 0.6 inch dia.
FND-100GH	2.5	5.1	0.64	920	8.5	<1n	10	-	150	100	TO-5
FND-100QH	2.5	5.1	0.64	920	8.5	<1n	10	-	150	100	TO-5, response down to 200 nm
UV-040BQH	1	0.81	0.62	900	25	-	-	>500	-	0	TO-5, response down to 200 nm
UV-100BQH	2.5	5.1	0.62	900	150	-	-	>100	-	0	TO-5, response down to 200 nm
UV-215BGH/340	0	-	-	-	-	-	-	-	-	0	TO-5, response down to 250 nm
UV-215BQH	5.5	23.4	0.62	900	700	-	-	>50	-	0	TO-5, response down to 200 nm
UV-245BGH	5	18.5	0.62	900	630	-	-	>75	-	0	TO-5, response down to 250 nm
UV-245BQH	5	18.5	0.62	900	630	-	-	>75	-	0	TO-5, response down to 200 nm
YAG-100AH	2.5	5.1	0.7	1000	2.5	5	<20	-	>200	180	TO-5
YAG-200H	5	20	0.7	1000	6	5	<100	-	>200	180	TO-8
YAG-444AH	11.3	100	0.7	1000	35	5	<200	-	>200	180	TO-36
SR10DE	-	0.56 x 0.56	-	-	4	150	10	-	170	-	SMT
SR10DE-B	-	6.71	-	-	4	150	10	-	170	-	SMT

Product Table

Specialty Silicon Detectors

Unit	Description	Active Diameter mm	Active Area mm ²	Capacitance pF	Rise/Fall Time ns	Dark Current nA	Breakdown Voltage min V	Responsivity 900 nm A/W	Responsivity 1060 nm A/W	Noise Current pA/sqrt(Hz)	Package
C30845EH	900 nm Quadrant PIN	8	50	8	6	70 nA	100	0.6	0.17	0.26	TO-8
YAG-444-4AH**	1064 nm Quadrant PIN	11.5	100	9	12	30	200	0.6	0.5	0.2	Custom
YAG-444N-4AH	1064 nm Quadrant PIN	11.5	100	9	12	30	200	0.6	0.5	0.1	Custom
YAG-555-4AH	1064 nm Quadrant PIN	14.1	156	12	12	50	200	0.6	0.5	0.2	Custom
YAG-555N-4AH	1064 nm Quadrant PIN	14.1	156	12	12	50	200	0.6	0.5	0.1	Custom
C30665GH-4A	1550 nm Quadrant PIN	3	7	115	14	2	50	0.8	1.05	0.08	TO-5
DTC-140H	Dual wavelength detector Si-Si (Top/Bottom)	3.5	9.9	300/300	-	50 / 50 MΩ	-	0.6/0	0.25 / 0.15	0.033 / 0.133	Custom

* Responsivity is measured at 900 and 1064 nm for 1064 nm quadrant PINs, and 1064 and 1550 nm for 1550 nm quadrant PINs.

** The YAG series of quadrant PIN photodiodes are available with built-in heater package, upon request.

PIN and APD Hybrid Receivers

For Analytical and Industrial Applications

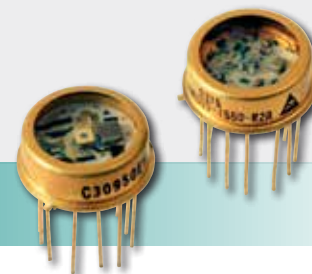

Si PIN and APD Modules – InGaAs APD Modules

Applications

- Laser range finder
- Video scanning imager
- High speed analytical instrumentation
- Free space communication
- UV-VIS-NIR light sensing
- Distributed temperature sensing

Features and Benefits

- Ultra low noise
- High speed
- High transimpedance gain
- Customization available upon request

Product Description

These hybrid receivers comprise of a photodetector (PIN or APD) and a transimpedance amplifier in the same hermetically-sealed package. Having both amplifier and photodetector in the same package allows low noise pickup from the surrounding environment and reduces parasitic capacitances from interconnect allowing lower noise operation.

The C30659 series includes an APD connected to a low noise transimpedance amplifier. 4 models are offered with a Silicon APD and 2 models offered with an InGaAs APD. Standard band-width of 50 MHz and 200 MHz can accommodate a wide range of applications. The C30659 models are offered with the APD mounted on a thermo-electric cooler (the LLAM series) to help improve noise or to keep the APD at constant temperature regardless of the ambient temperature.

The C30659 can be customized to meet application specific requirements by using one of the Excelitas rear entry APDs, by choosing a custom bandwidth or by qualifying it to your environmental conditions. Pigtailed versions are also available in a 14 pins DIL package allowing nearly 100% coupling efficiency.

Both the C30659 and LLAM series have options for enhanced higher damage thresholds, thus providing greater resilience when exposed to high optical power densities. The C30950EH offers a low cost alternative to the C30659. The amplifier is designed to neutralize the input capacitance of a unity voltage gain amplifier. The C30919E uses the same architecture of the C30950EH with the addition of a high voltage temperature compensation circuit which maintain module responsivity constant over a wide temperature range.

The HUV modules are offered with a PIN detector for low frequency high gain application, covering a broad spectrum range from the UV to the near IR. All optical receiver products can be qualified to meet the most demanding environmental specification as described in MIL-PRF-38534.

Figure 1

APD Receiver Responsivity vs. Wavelength

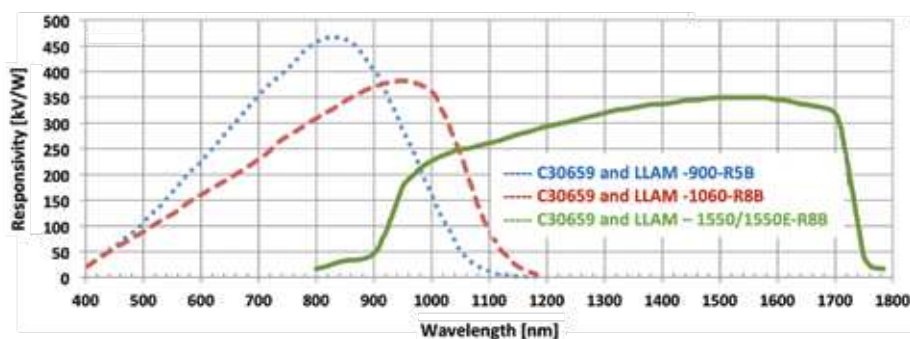

Si PIN and APD Modules – InGaAs APD Modules

Unit	Detector	Active Diameter	Bandwidth	Responsivity, 900 nm	Responsivity, 1060 nm	Responsivity, 1550 nm	NEP	Output Voltage Swing, 50 Ohm	Package
		mm	MHz	kV/W	kV/W	kV/W	fW/Hz	V	
C30659-900-R5BH	C30902	0.5	200	400	-	-	40	0.9	TO-8
C30659-900-R8AH	C30817	0.8	50	3000	-	-	12	0.9	TO-8
C30659-1060-R8BH	C30954	0.8	200	370	200	-	100	0.9	TO-8
C30659-1060-3AH	C30956	3	50	450	280	-	90	0.9	TO-8
C30659-1550-R08BH	C30645	0.08	200	-	-	90	220	0.9	TO-8
C30659-1550E-R08BH*	C30645	0.08	200	-	-	90	220	0.9	TO-8
C30659-1550-R2AH	C30662	0.2	50	-	-	340	130	0.9	TO-8
C30659-1550E-R2AH	C30662	0.2	50	-	-	340	130	0.9	TO-8
C30919E	C30817	0.8	40	1000	250	-	20	0.7	TO, 1 in
C30950EH	C30817	0.8	50	560	140	-	27	0.7	TO-8
LLAM-1550-R08BH	C30645	0.08	200	-	-	90	220	0.9	TO-8 FLANGE
LLAM-1550E-R08BH	C30645	0.08	200	-	-	90	220	0.9	TO-8 FLANGE
LLAM-1550-R2AH	C30662	0.2	50	-	-	340	130	0.9	TO-8 FLANGE
LLAM-1550E-R2AH	C30662	0.2	50	-	-	340	130	0.9	TO-8 FLANGE
LLAM-1060-R8BH	C30954	0.8	200	370	200	-	55	0.9	TO-8 FLANGE
LLAM-1060-R8BH-FC	C30954	0.8	200	370	200	-	55	0.9	TO-8 FLANGE+FC
HUV-1100BGH	UV-100	2.5	0.001	130 MV/W	-	-	30	5 min	CUSTOM
HUV-2000BH	UV-215	5.4	0.001	130 MV/W	-	-	70	6 min	CUSTOM
Helix-902-200	C30902	0.5	200	1300	-	-	50	1	CUSTOM

* "E" versions of the receivers are with enhanced damage threshold over exposure protection feature.

Figure 1

C30659

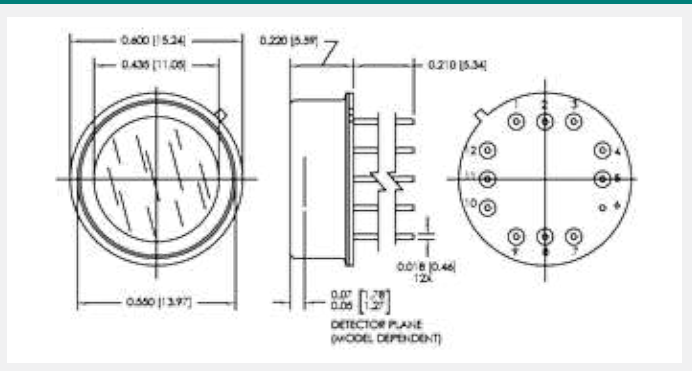

Figure 2

C30659 Series Field of View

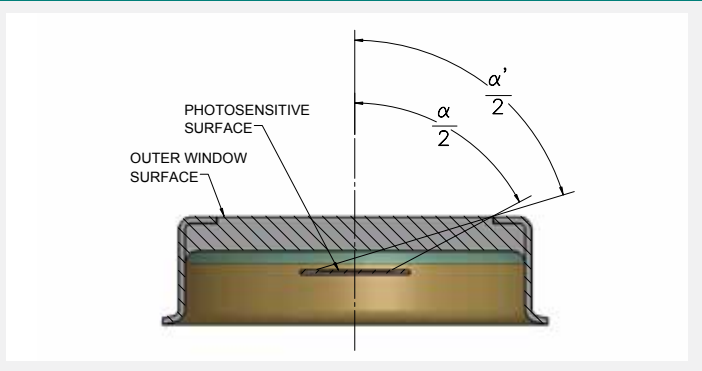

Figure 3

To Flange package for TEC Devices

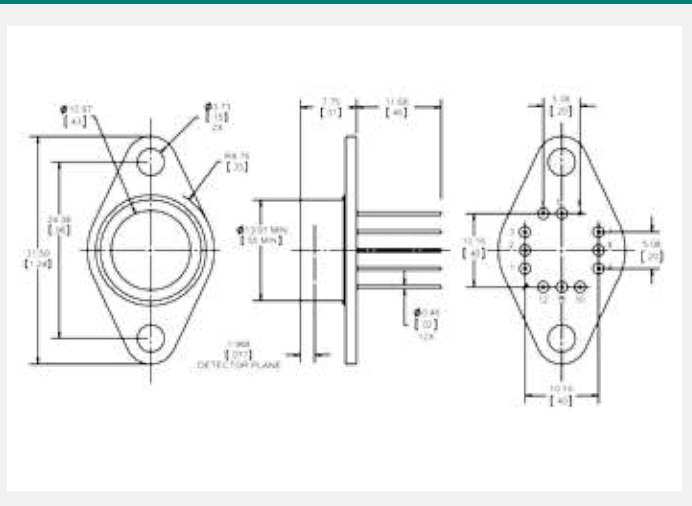
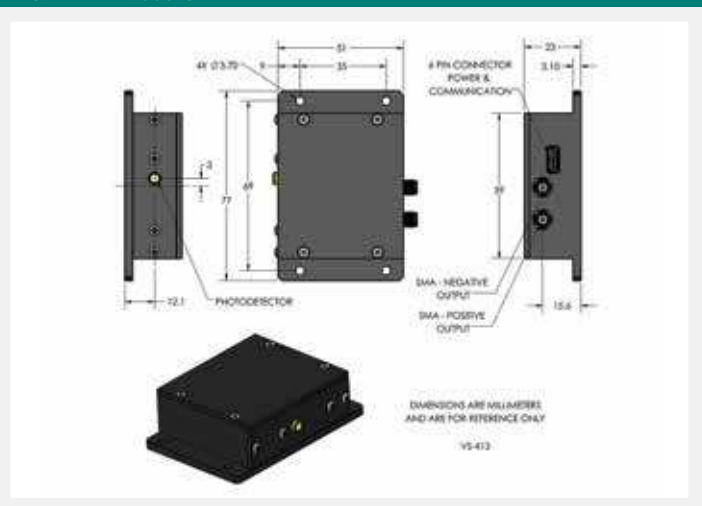

Figure 4

Helix APD Module



Low Light Level (L³D) Detectors & Modules

For Analytical, Life science & Biomedical Applications

LOW LIGHT LEVEL (L³D) DETECTORS & MODULES ■

Single Photon Counting Modules (SPCM)



Single Photon Counting Modules – SPCM

Applications

- Particle sizing
- Confocal microscopy
- Photon correlation spectroscopy
- Quantum cryptography
- Astronomical observation
- Optical range finding
- Adaptive optics
- Ultra sensitive fluorescence

Features and Benefits

- Peak photon detection efficiency at 650 nm: 70 % typical
- Active area: 180 μm diameter
- Gated output
- Single +5V supply
- FC receptacle option for fiber coupling
- EU RoHS compliant
- Array of 4 channels available
- Customization available upon request

Product Description

The SPCM-AQRH is a self-contained module that detects single photons of light over the 400 nm to 1100 nm wavelength range - a range and sensitivity that often outperforms a photomultiplier tube. The SPCM-AQRH uses a unique silicon avalanche photodiode (SLiK) with a circular active area that achieves a peak photon detection efficiency of more than 65 % at 650 nm over a 180 μm diameter. The photodiode is both thermoelectrically cooled and temperature controlled, ensuring stabilized performance despite ambient temperature changes. Circuit improvements have reduced the overall power consumption.

Count speeds exceeding 40 million counts per second (Mc/s) are achieved by the SPCM-AQRH-WX module. There is a "dead time" of 22 ns between pulses.

As each photon is detected, a TTL pulse of 2.2 Volts (minimum) high into a 50 Ohm load and 10ns wide is output at the rear BNC connector. Other values for the dead time and pulse width are available as indicated on product data sheet.

The module is designed to give a linear performance at a case temperature between 5° C and 40° C.

The SPCM is also available in the following formats:

- 4 channel array SPCM-AQ4C,
- Timing resolution enhanced SPCM-AQRH-XX-TR,
- NIR optimized SPCM-NIR-XX.

This series of photon counting modules are designed and built to be fully compliant with the EMC Directive 2014/30/ZU, and restriction of the use of certain Hazardous Substances in electrical and electronic equipment (RoHS).

Graph 1

Characteristics SPCM Series

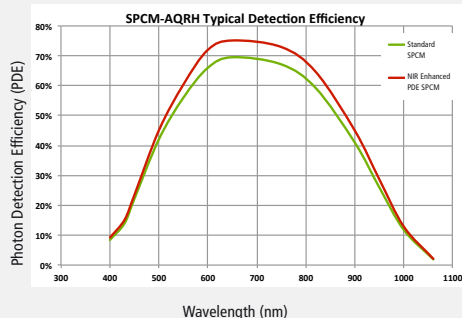

Product Table

Single Photon Counting Modules – SPCM

Part Number	Photo Sensitive Diameter	Maximum Dark Count Rate	Photon Detection Efficiency @ 650 nm	Max. Count Rate before Saturation	Dead Time ⁴	Pulse Width ⁵
Unit	mm	c/s	%	c/s	ns	ns
SPCM-AQRH-10	0.18	1500	65	40M	22	10
SPCM-AQRH-11	0.18	1000	65	40M	22	10
SPCM-AQRH-12	0.18	500	65	40M	22	10
SPCM-AQRH-13	0.18	250	65	40M	22	10
SPCM-AQRH-14	0.18	100	65	40M	22	10
SPCM-AQRH-15	0.18	50	65	40M	22	10
SPCM-AQRH-16	0.18	25	65	40M	22	10
SPCM-AQRH-XX-TR ¹	0.18	100-1500	65	40M	22	10
SPCM-NIR-XX ¹	0.18	100-1500	75	40M	22	10
SPCM-AQ4C	fibered	500	60	>2M/channel	50	30
C30902SH-TC ²	0.475	2500	>5	-	-	-
C30902SH-DTC ³	0.475	350	>5	-	-	-

1. XX=dark count rates as per standard AQRH series above

2. C30902SH-TC @ 0°C operation

3. C30902SH-DTC @ -20°C operation

4. Option for 28ns & 35ns dead time available

5. Option for 18ns & 28ns pulse width available

Figure 1

Mechanical Dimensions of the SPCM-AQRH Series

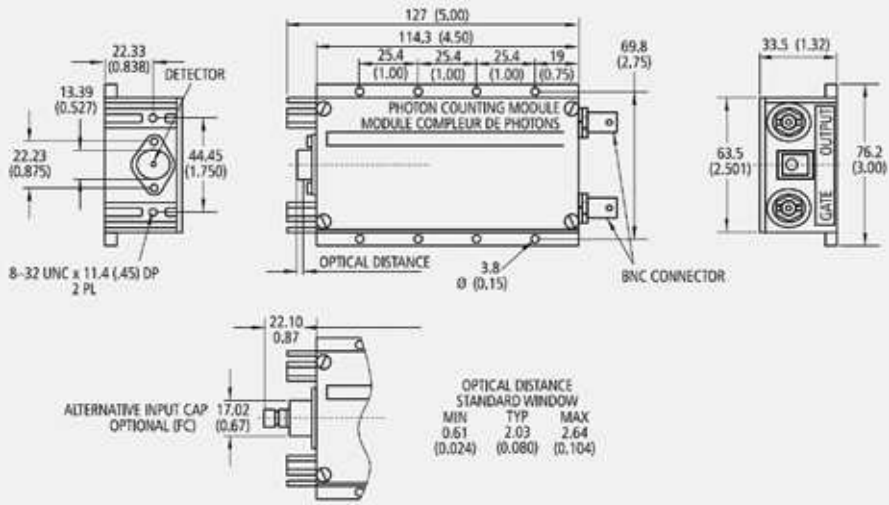

Figure 2

Mechanical Dimensions of the SPCM-AQ4C

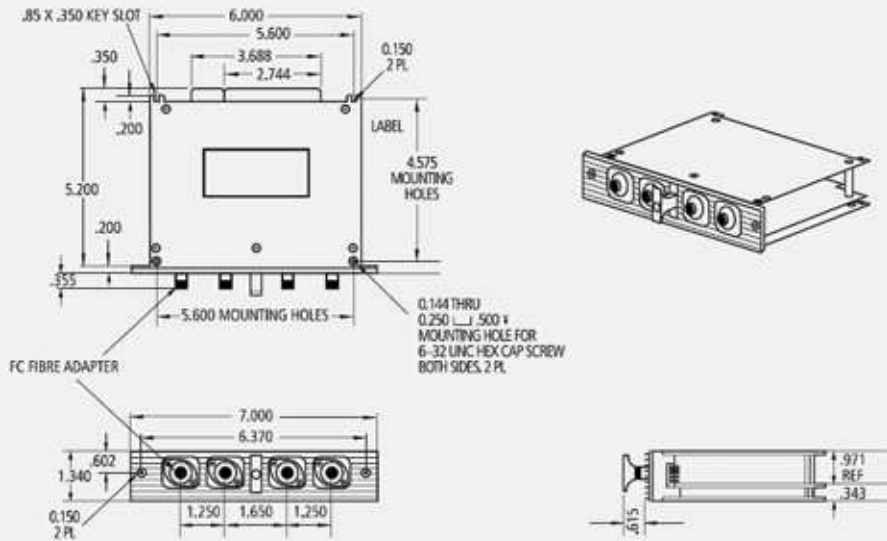
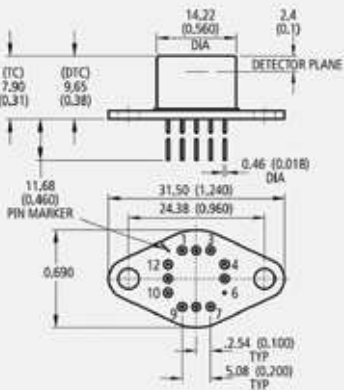

Figure 3

Package Drawing – TO-8 Flange



Low Light Level (L³D) Detectors & Modules

For Analytical, Life science & Biomedical Applications

Lynx SiPM & Helix APD Module



Lynx SiPM module – Applications

- Fluorescence measurement
- Analytical instrumentation
- Flow cytometry

Features and Benefits

- High responsivity:
 - 0.75 V/nW @ 525 nm (typ.)
 - 0.4 V/nW @ 700 nm (typ.)
- Excellent signal to noise ratio as compared to traditional PMTs
- High dynamic range and linearity
- Low NEP
- Built-in TE cooler
- Compact and user-friendly
- RoHS-compliant

Helix APD module – Applications

- Particle sizing
- Confocal microscopy
- Photon correlation spectroscopy
- Quantum cryptography
- Astronomical observation
- Optical range finding
- Adaptive optics
- Ultra sensitive fluorescence

Features and Benefits

- High responsivity: 1300KV/W @ 900 nm
- Transimpedance amplifier
- 50Ω SMA output connector
- Temperature compensation to stabilize gain and responsivity
- User controllable gain and responsivity
- Single + 5V operating voltage at input provides HV and LV internal biases for APD and TIA
- Front plate can accommodate various APDs
- User-friendly compact footprint
- RoHS Compliant
- Customization available upon request

Product Description

The HeliX™ Silicon Avalanche Photodiode (APD) Module and LynX™ Silicon Photomultiplier Module series are compact, easy-to-use, analogue low-light-level detection (L³D) modules employing Excelsitas' leading-edge Si APD and SiPM chips.

The Helix APD module is in a hermetic TO package, mounted on a practical OEM based PCB which includes high-voltage power supply, temperature compensation, a low-noise transimpedance amplifier, APD bias monitor and micro-controller. With this compact voltage-output module, the preamplifier gain is optimized to obtain maximum dynamic range and linearity with the APD at gain adjustable operating voltage. It optimizes APD operation in key performance parameters such as higher sensitivity, and better signal-to-noise ratio across the 400 nm - 1100 nm wavelength range. Standard modules available with the C30902EH or the C30954EH APDs.

The Lynx SiPM module is in a hermetic TO-8 package with thermoelectric cooler, a stable voltage power supply circuit, and a low noise transimpedance amplifier. This compact voltage output module has the preamplifier gain optimized to obtain maximum dynamic range and linearity with the SiPM at pre-set operating voltage. It outperforms other SiPM solutions in key performance parameters such as higher photon detection efficiency (PDE) and better signal-to-noise ratio across the full 400 nm - 900 nm wavelength spectrums.

Both of these user-friendly full modules are offered as a standard, commercial-off-the-shelf (COTS) product. Excelsitas also offer customized modules tailored to the needs of the customer. Depending upon customer requirements, modifications can include a different APD, optional calibration, bandwidth optimization, FC-connectorized packaging, and customized testing.

Product Table				
Lynx Module				
Parameter	Min.	Type	Max.	Unit
Effective Active Area		3 x 3		mm
Microcell Size		50 x 50		µm
Spectral Bandwidth	350		950	nm
Peak Wavelength		500		nm
Positive Supply Voltage	4.5	5	5.5	V
Positive Supply Current		350	1000	mA
Power Up Settling Time		15		s
Output Voltage Swing			5	V
			1	V
Responsivity		0.75		V/nW
Bandwidth	1	1.5		MHz
NEP		1		fW/(Hz) ^{1/2}
Output Offset Voltage		1.5		mV
Storage Temperature	-10		50	°C
Operating Temperature	5		50	°C

Product Table				
Helix module -Silicon reach-through APD C30902EH				
Parameter	Min.	Type	Max.	Unit
Active Area Chip Diameter		0.5		mm
Peak Wavelength (λ)		900		nm
Module Responsivity (differential)				KV/W
at 830 nm		1540		
at 900 nm		1300		
-3dB Electrical Bandwidth		200		MHz
Low Frequency Cut-off		1.5		kHz
Noise Equivalent Power (NEP)				fW/√Hz
at 830nm		42		
at 900nm		50		
Rise Time ⁽¹⁾		1.5		ns
Positive Supply Voltage	4.5	5	5.5	V
Positive Supply Current		350	1000	mA
Storage Temperature	-10		70	°C
Operating Temperature	5		60	°C

Low Light Level (L³D) Detectors & Modules

For Analytical, Life science & Biomedical Applications



Coherent InGaAs PIN Balanced Receiver Module

Applications

- Spectroscopy
- Optical delay measurement
- Heterodyne detection
- Optical coherent tomography
- Ellipsometry
- Ultra low signal detection

Features and Benefits

- Spectral range — 800-1650 nm
- 200 MHz bandwidth
- High performance InGaAs photodiode and TIA
- Matching responsivity
- Photo-current monitor outputs
- Rugged and robust
- RoHS compliant
- Customization available upon request

Product Description

In the CIPRM-1 series balanced optical receiver Excelitas has the best features of high performance InGaAs photodiodes and low noise, high gain transimpedance amplifier to offer a practical solution to detect small changes above the interfering noise floor of incoming signal. The advantage is that the common optical noise is cancelled out.

This receiver incorporates two low-noise photodiodes with well-matched responsivity in order to ensure a high common mode rejection ratio (CMRR). It has two single mode fiber optic inputs, an RF output, electrical supply inputs, and two photo-current monitor outputs. Module is also available with two FC receptacle inputs.

The CIPRM modules come in a robust casing with flange mounting holes for securing the module to working surfaces or platforms. Combined with a wide operating temperature range, the CIPRM can work in some of the toughest and harshest environments.

Excelitas' series of optical balanced receiver modules are designed and built to be fully compliant with the European Union's RoHS Directive 2011/65/EU.

Product Table

CIPRM-110 & CIPRM-210 MODULE

Parameter	Typical Specification	Notes
Wavelength Range	800-1700 nm	
Detector Material	InGaAs	
Detector Diameter	0.1 mm	
Detector Responsivity (Peak)	0.95 (A/W)	@1550 nm + fiber
Optical Input	FC/APC	9/125 with 900 µm buffer
Photo-current Monitoring Coefficient	10 V/mW	
Transimpedance Gain	32x10 ³ V/A	
Conversion Gain, Maximum	30x10 ³ V/W	
Integrated Noise	100 nW	NEP*√BW (at input)
Bandwidth (-3 dB)	2.5kHz - 200MHz	
Rise Time	2ns	
Common Mode Rejection	30 dB	
NEP	5 pW/√Hz	
Overall Output Voltage Noise	3 mV	Measured
Output Impedance	50 Ω	
Saturation Optical Power CW	200 µW	CW unbalanced
Maximum Input Power	0.35 mW	Balanced, differential signal
Saturation Optical Power	10 mW	Balanced, max
Output Connector	SMA	
Maximum RF Power	+11dBm in 50Ω	
Power Requirements	±12V DC	Supply voltage
	I _{+12V} = 32 mA	
	I _{-12V} = 5 mA	Supply current

Figure 1

CIPRM Module

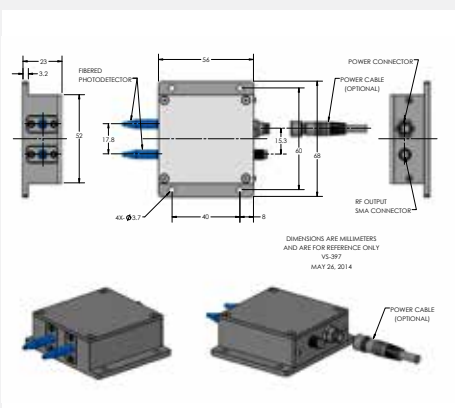

High Power Laser Diode

For Range Finding

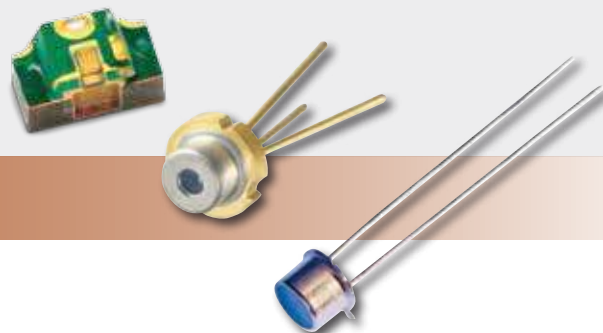

Pulsed Laser Diodes – PGA – PGEW Series

Applications

- Range finders
- Safety light curtains
- Adaptive cruise control
- Autonomous vehicles
- LIDAR
- Laser therapy

Features and Benefits

- Multi-cavity lasers concentrate emitting source size
- Quantum well structure
- High peak pulsed power into aperture
- Excellent power stability with temperature
- Customization available upon request

Product Description

Pulsed semiconductor lasers in the near IR are commonly used for long-distance time-of-flight or phase-shift range-finder or LIDAR systems. Excelitas offers a broad range of ideally-suited pulsed 905 nm laser designs including multi-cavity monolithic structures with up to 4 active areas per chip resulting in up to 100 W of peak optical output power. Physical stacking of laser chips is also possible, resulting in up to 300 W of peak optical output power.

Chip-on-board assemblies are available for hybrid integration. A selection of 6 metal, hermetically-sealed package types are available for harsh environment applications. A molded epoxy resin TO-18 type package and a surface-mount overmoulded chip-on-ceramic package are available for high-volume applications.

Critical parameters are pulse-width and rise/fall times. The pulse width may be reduced allowing for increased current drive and resulting in higher peak optical power. Quantum-well laser design offers rise and fall times of <1ns but the drive circuit lay-out and package inductance play the greater role in determining rise/fall times, and should be designed accordingly. Excelitas offers a variety of package types with different inductance values to assist to this end.

Our core competencies include: MOVPE wafer growth; wafer processing of the grown GaAs wafers; assembly using either epoxy or solder die attach; epoxy encapsulation of lasers mounted on lead frame; hermetically-sealed product qualification to MIL STD and custom requirements.

Product Table

PGA Pulsed Laser Family Selection Table, Typ. Wavelength 905 nm, 5 nm Spectral Width

Device (X = pkg) (H = RoHS Compliance)	Description		Emitting Area		Typical Peak Power at 10A, 100 ns	Typical Peak Power at 30A, 100 ns	Beam Spread Parallel to Junction (FWHM)	Beam Spread Perpendicular to Junction (FWHM)	Typical Temperature Coefficient nm / °C	Preferred Packages		
	# of Chips	Total # of Emitting Stripes	Width µm	Height µm	75 µm (3 mils) Stripe Width	225 µm (9 mils) Stripe Width	Θ	Θ _⊥		"S" Metal Can TO-18	"LU" High Volume Metal TO-56	"D" Epoxy Encapsulated SMT
					8 W	25 W	10	25		✓	✓	✓
PGAx1S03H	1	1	75	1	8 W		10	25	0.25	✓		✓
PGAx1S09H	1	1	225	1		25 W	10	25	0.25	✓		✓
DPGAx1S03H	1	2	75	5	16 W		10	25	0.25	✓	✓	✓
DPGAx1S09H	1	2	225	5		50 W	10	25	0.25	✓		✓
TPGAx1S03H	1	3	75	10	23 W		10	25	0.25	✓	✓	✓
TPGAx1S09H	1	3	225	10		75 W	10	25	0.25	✓	✓	✓
QPGAx1S03H	1	4	75	15	30 W		10	25	0.25	✓	✓	✓
QPGAx1S09H	1	4	225	15		90 W	10	25	0.25	✓		✓
TPGAx2S03H	2	6	75	175	45 W		10	25	0.25	✓		
TPGAx2S09H	2	6	225	175		150 W	10	25	0.25	✓		
QPGAx2S03H	2	8	75	225	58 W		10	25	0.25	✓		
QPGAx2S09H	2	8	225	225		175 W	10	25	0.25	✓		
QPGAx3S03H	3	12	75	450	85 W		10	25	0.25	✓		
QPGAx3S09H	3	12	225	450		255 W	10	25	0.25	✓		

Graph 1

Peak Radiant Intensity vs. Temperature

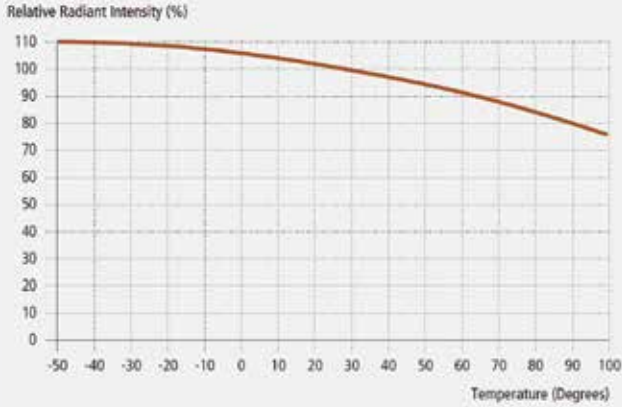

Graph 4

Radiant Intensity vs. Pulse Width for Safe Operation

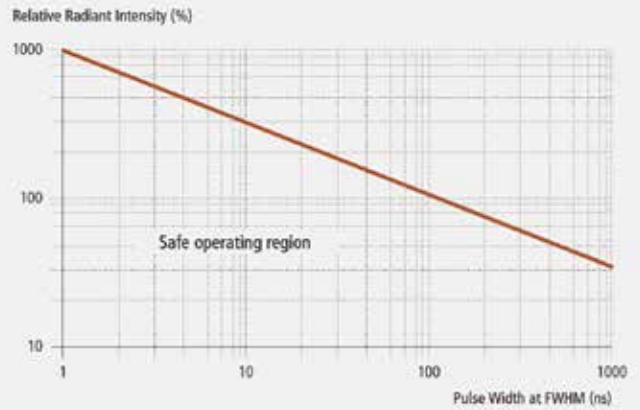

Graph 3

Spectral Plot Distribution

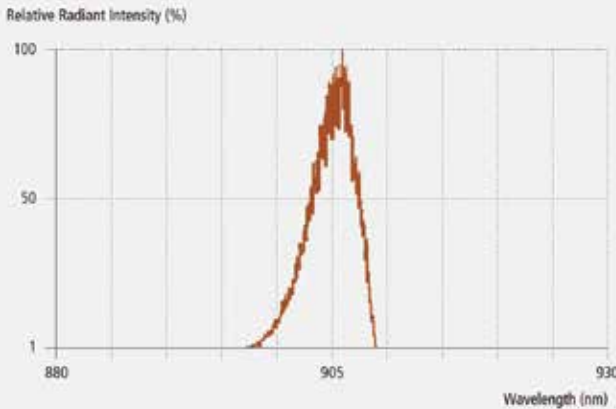

Graph 6

Center Wavelength vs. Temperature

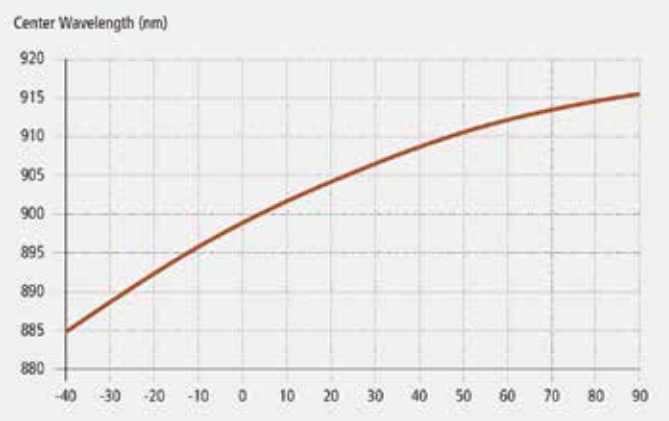
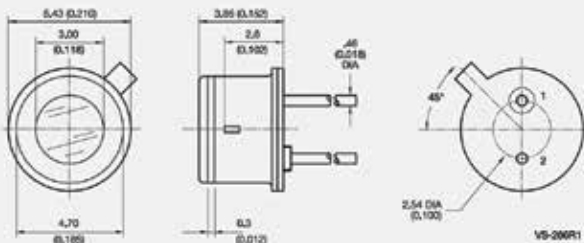

Figure 1

Package Drawing



Package S (TO-18)



Pin out
 1. LD Anode (+),
 2. LD Cathode (-) Case,
 Inductance 5.2 nH

Figure 2

Package Drawing

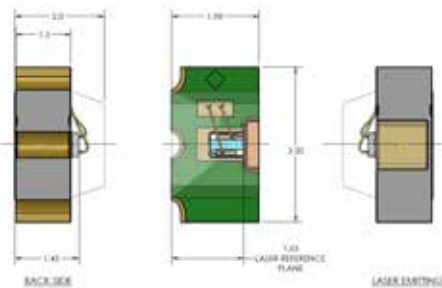

Package D (Surface Mount)



Inductance 1.6 nH

Figure 2

Package Drawing

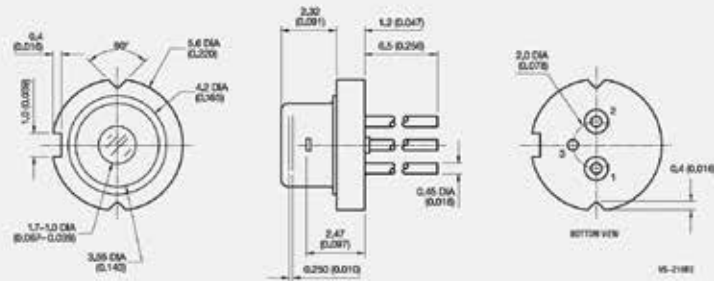

Package U (5 mm CD)



Pin out
 1. LD Anode (+),
 2. NC,
 3. LD Cathode (-) Case,
 Inductance 5.0 nH

Figure 3

Housing/Package Drawing • Laser Chip on Board

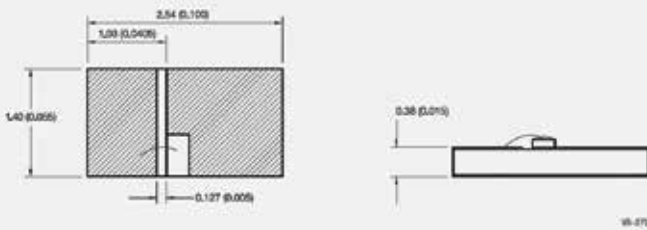

Package Y (Chip on Carrier)



Pin out
 1. LD Cathode (-) chip bottom,
 2. LD Anode (+) chip top,
 Inductance 1.6 nH

Figure 4

Package Drawing

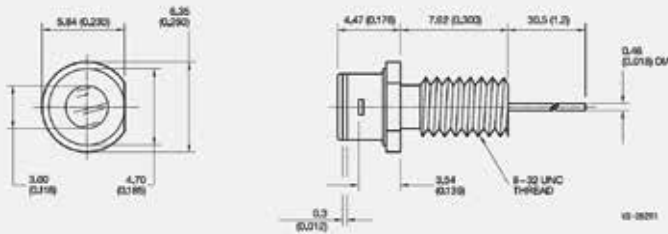

Package C (8-32 Coax)



Pin out
 1. LD Anode (+),
 2. LD Cathode (-) Case,
 Inductance 12 nH

Figure 5

Package Drawing

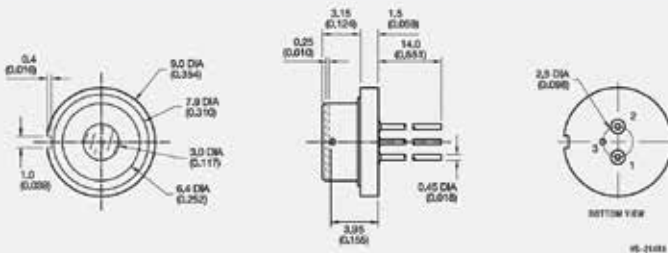

Package R (9 mm CD)

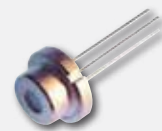

Pin out
 1. LD Anode (+),
 2. NC,
 3. LD Cathode (-) Case,
 Inductance 6.8 nH

Figure 6

Housing/Package Drawing • TO-18-“W” Plastic Package (1S Devices Only)

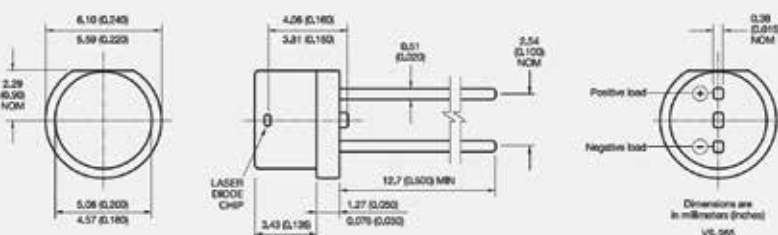

Package W (TO-18 Plastic)



Pin out
 1. (Pkg Flat) LD Anode (+),
 2. LD Cathode (-),
 Inductance 5.0 nH

Optoelectronic Components

For Smoke Detector Applications

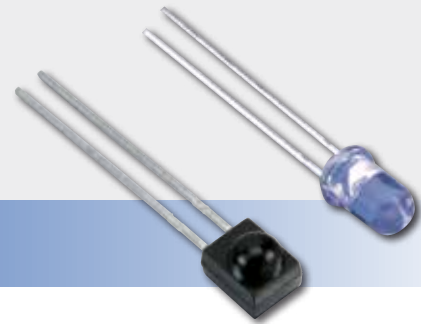

Selected Photodiodes and Infrared Emitting Diodes (IREDs)

Applications

- Electro-optical smoke detection

Features and Benefits

- High quality components: photodiodes, IREDs (UL- listed)
- Binning for optimized transfer function
- Customized optical block (PD+IRED) assemblies
- Smoke chamber assemblies according specified transfer function

Product Description

An electro-optical smoke detector consists of an Infrared LED (IRED) and Photodiode (PD) assembly, which exhibits a signal under the presence of smoke in the detection volume (smoke chamber). Signal range under smoke and clean-air conditions and their long term stability are key features of a smoke detector module. Excelitas offers IRED and PD components as well as customized assemblies with specified signal level range. Such an assembly can be an optical block containing an IRED and PD for (SMD) board soldering or the complete smoke chamber, which are produced in high-volumes. Please contact Excelitas to discuss your requirements.

In addition to the components presented in the table below, Excelitas can provide higher value-add assemblies, including the following for smoke detection applications:

- 1) An optics block which consists in a Photodiode-IRED pair selected, assembled into a plastic housing and tested to have a controlled range of transfer function between the IRED to photodiode signal under given smoke conditions.
- 2) A smoke chamber with base which can be easily integrated on a PCB for use with the optics block.

For further details on these or other sub-assemblies, including readout ICs, please contact Excelitas.

Product Table

Selected Photodiodes Used in Smoke Detection Applications

Symbol	Package	Active Area (mm ²)	Minimum Short Circuit Current @ 100fc, 2850K	Maximum Dark Current @ VR = 10V	Maximum Junction Capacitance	Radiometric Sensitivity @ λ _p typ	Spectral Range λ _{RANGE}	Peak Wavelength λ _p	Noise Equivalent Power typ
Unit		mm	μA	nA	(pF)	S _R	nm	nm	W/Hz
VTP7840H	Lensed Sidelooker IRT	5.27	50	20	40 @V _R = 3V	0.55	725-1150	925	5.3 X 10-14
VTP413H	Lensed Sidelooker IRT	7.45	120 (Typical)	20	50 @V _R = 0V	0.55	725-1150	925	2.3 X 10-14
VTP100H	Flat Sidelooker IRT	7.45	35	30	50 @V _R = 3V	0.5	725-1150	925	2.5 X 10-14
VTP1188SH	Lensed Ceramic	11	200 (Typical)	30 @V _R = 10mV	300 @V _R = 0V	0.55	400-1100	925	-
VTP1232H	T-1 3/4 lensed	2.326	100	25	100 @V _R = 0V	0.6	400-1100	920	-
VTP3410LAH	T-1 lensed IRT	0.684	15	35 @V _R = 50V	25 @V _R = 3V	0.55	700-1150	925	1.9 X 10-13
VTP3420LA	T-1 lensed IRT	1.64	34	35	150 @V _R = 0V	0.55	700-1150	925	-

Product Table

Selected Infrared LEDs (IREDs) Used in Smoke Detection Applications

Symbol	Package	Typical Total Power (mW)	Typical Irradiance (mW/cm ²)	Test Current/ Pulsed (mA)	Typical Forward Voltage Drop (V)	Wavelength (nm)	Half Power Beam Angle
VTE1291-1H	T-1 3/4 lensed	20	3.3 ⁽¹⁾	100	1.5	880	±12°
VTE1291-2H	T-1 3/4 lensed	25	6.5 ⁽¹⁾	100	1.5	880	±12°
VTE1295H	T-1 3/4 lensed	20	5.5 ⁽¹⁾	100	1.5	895	±8°
VTE3374LAH	T-1 lensed	5	5.2 ⁽²⁾	20	1.3	880	±10°
VTE3375LA	T-1 lensed	3	2 ⁽²⁾ (Min.)	20	1.3	880	±12.5°
VTE3310	T-1 lensed	1	0.5 (Min.)	20	3.2	460	±5°

(1): Tested at 36mm on a 6.4mm diameter.

(2): Tested at 10.16mm on a 2.1mm diameter.

Ambient Light Sensors

Left: Spectrally Adapted Photodiodes and Phototransistors

Right: C30737PH Series T-1 3/4 (TO-like) Through-Hole Package (4.9 mm Diameter)

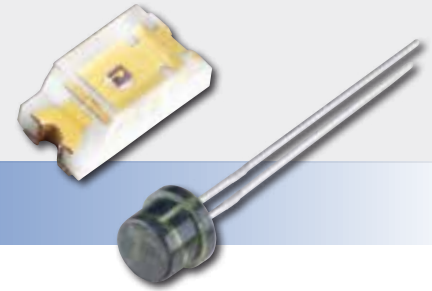

Spectrally Adapted Photodiodes and Phototransistors

Applications

- Interior and exterior light switching (dusk/dawn switch)
- Interior and exterior light control (dimming)
- Automotive headlight dimmer
- Display contrast control
- Energy conservation

Features and Benefits

- Response approaching human eye using Excelitas' IR-BLOC™ technology
- Perfect light sensor in conjunction with Excelitas' pyroelectric detectors for motion controlled light switches
- RoHS compliant
- Selectable wavelength detection range
- Small footprint
- Surface mount packages

Product Description

Ambient light sensors from Excelitas provide an easy solution for applications that require a response similar to the human eye, making it ideal when the response should only be influenced by visible light. These devices contribute in various applications to energy conservation in both fixed and portable devices. There are three main device types, one being filtered photodiodes, the second filtered phototransistors and finally wavelength selective devices based on III-V material. They are available in a number of standard packages, including surface mount for automated assembly.

Product Table

Spectrally Adapted Photodiodes and Phototransistors											
Symbol	Package	Active Area mm ²	Min. Short Circuit Current @ H=100fc, 2850K		Maximum Dark Current (nA)	Maximum Junction Capacitance (nF)	Typical Radio-metric Sensitivity @ λ _p		Spectral Range λ _{RANGE} nm	Typical Peak Wavelength λ _p nm	Typical Noise Equivalent Power (W/Hz)
			min I _{sc} μA	Maximum			typ S _r A/W	λ _p			
VTP9812FH	T-1 3/4 flat	1.548	0.7	10 @ V _R = 10V	0.15 @ V _R = 10V	0.15 @ V _R = 10V	0.034	400-700	580	-	
VTB1012BH	TO-46	1.6	0.8	0.1 @ V _R = 2V	0.31 @ V _R = 0V	0.31 @ V _R = 0V	0.3	330-720	580	5.3 X 10 ⁻¹⁴	
VTB1013BH	TO-46	1.6	0.8	0.02 @ V _R = 2V	0.31 @ V _R = 0V	0.31 @ V _R = 0V	0.3	330-720	580	1.1 X 10 ⁻¹⁴	
VTB6061CIEH	TO-8	37.7	-	2 @ V _R = 2V	11 @ V _R = 0V	11 @ V _R = 0V	-	475-650	555	1.3 X 10 ⁻¹³	
VTT9812FH	T-1 3/4 flat	0.192	60	50 @ V _{CE} = 5V	-	-	0.7	450-700	585	-	
VTT9814FH	T-1 3/4 flat	0.192	80 (min) 120 (max)	50 @ V _{CE} = 5V	-	-	0.7	450-700	585	-	

Electrical characteristics at T_{Ambient} = 25 °C

Graph 1

VTT9812FH Typical Spectral Sensitivity @ 25° C

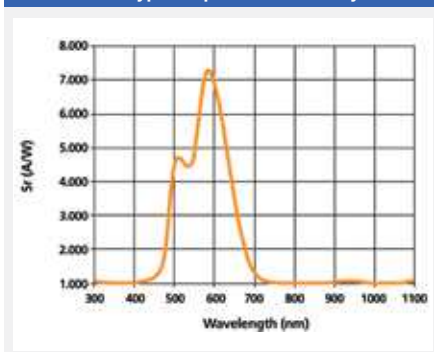

Graph 2

VTT9812FH Output Versus Low Light Levels

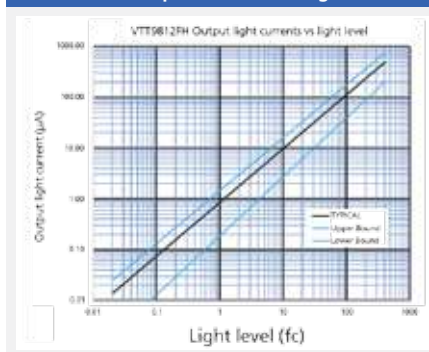

Graph 3

VTT9814FH Output Versus Low Light Levels

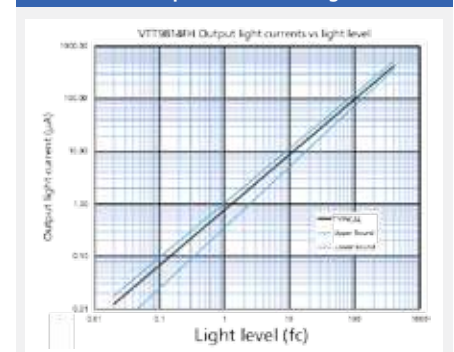

Photodiode Arrays

For X-ray Security Applications

SILICON PHOTODIODE ARRAYS ■

Left: 16 Element, 1.6 mm Pitch Photodiode Array With Segmented Csi Scintillator.

Right: 16 Element, 2.5 mm Pitch Photodiode Array With GOS Low Energy Screen Scintillator.

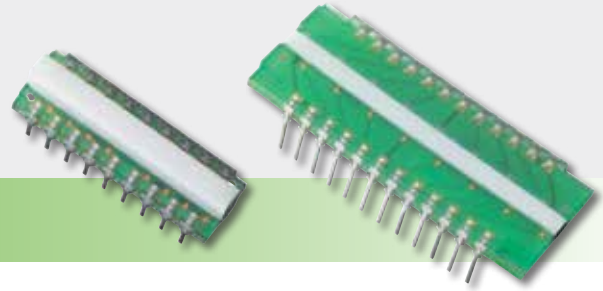

Photodiode Arrays – VTA Series

Applications

- Luggage scanning
- Cargo & container scanning
- Food inspection
- Non-destructive testing

Features and Benefits

- Various crystal types available (Csl, GOS, etc.)
- Custom chip geometry & pitch
- Single or dual-sided assemblies
- High responsivity and low capacitance
- Onboard electronics available on a custom basis
- Multiple photodiode rows

Product Description

These photodiode arrays are used to generate an X-ray image by scanning an object line by line. The X-rays are converted into light through the attached scintillator crystal. The light intensity is then measured by the photodiodes. The boards are employing chip-on-board technology with optically adapted scintillator crystals. The listed designs can be ordered as a standard part, but can also be customized to meet the needs of a wide variety of applications. Excelitas custom photodiode arrays give customers the option to choose the:

- active photodiode area
- total number of elements
- overall PCB and photodiode chip dimensions
- photodiode chip geometry and orientation
- electro-optical specifications
- single sided vs. double sided PCB
- alternative substrate materials (e.g. ceramic)
- electrical interface (e.g. connector)

First stage amplification electronics can also be added to the custom board design to convert the current generated by the photodiode into an easy to measure voltage.

Product Table

Photodiode Arrays • VTA Series

Symbol	Substrate		Active Area	Photodiode Chip Dimensions		Pitch	Number of Elements	Scintillator Crystal Type	Light Current Uniformity @ 540 nm, 30 nW/cm ²	Dark Current @ H=0, VR=10 mV		Junction Capacitance @ H=0, VR=0V		Radiometric Sensitivity @ 540 nm
	Material	Dimensions		Design	Design					typ	max	typ	max	min
			mm			mm ²	mm	mm						
Unit								%	pA	pA	pF	pF	A/W	
VTA2164H-D-NC-00-0	FR4	43.2x67.7	1.41	1.40x3.50	2.1	64	Custom	±5	<10	90	<100	200	0.30	
VTA1616H-H-SC-01-0	FR4	8.0x25.4	2.58	1.51x3.25	1.6	16	Csl	±5	-	50	-	350	0.30	
VTA1616H-L-SC-02-0	FR4	16.0x25.4	2.58	1.51x3.25	1.6	16	GOS	±5	-	50	-	350	0.30	
VTA2516H-H-SC-01-0	FR4	8.0x40.0	5.20	2.45x3.15	2.5	16	Csl	±5	-	50	-	600	0.30	
VTA2516H-L-SC-02-0	FR4	16.0x40.0	5.20	2.45x3.15	2.5	16	GOS	±5	-	50	-	600	0.30	
VTA1216H-H-NC-00-0	FR4	10.2x19.0	3.44	2.30x4.95 (dual cell)	1.2	16	Custom	±5	-	100	-	300	0.30	
VTA1216H-L-NC-00-0	FR4	17.8x19.0	3.44	2.30x4.95 (dual cell)	1.2	16	Custom	±5	-	100	-	300	0.30	
VTA0832H-H-NC-00-0	FR4	17.8x25.4	0.50	1.59x2.34 (dual cell)	0.8	32	Custom	±5	-	100	-	100	0.30	

Electrical characteristics at T_{Ambient} = 25 °C

Figure 1

Side 1 Detail VTA2164H-D

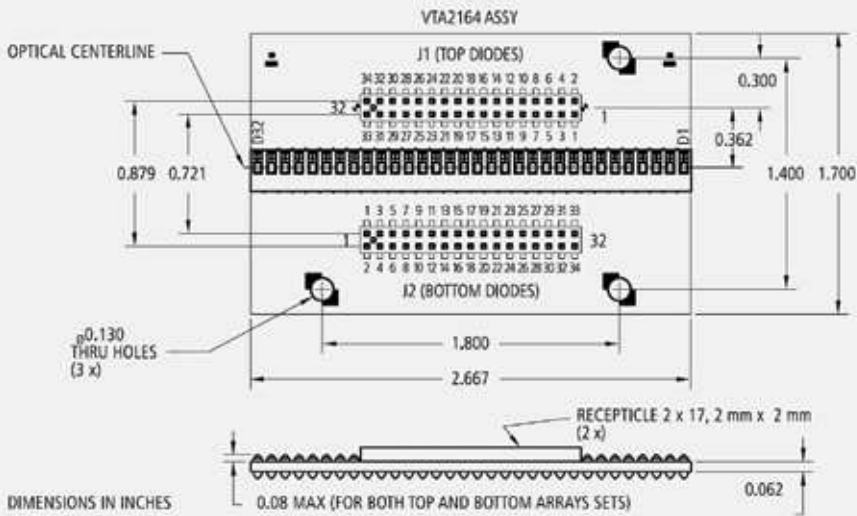

Figure 2

Side 2 Detail VTA2164H-D

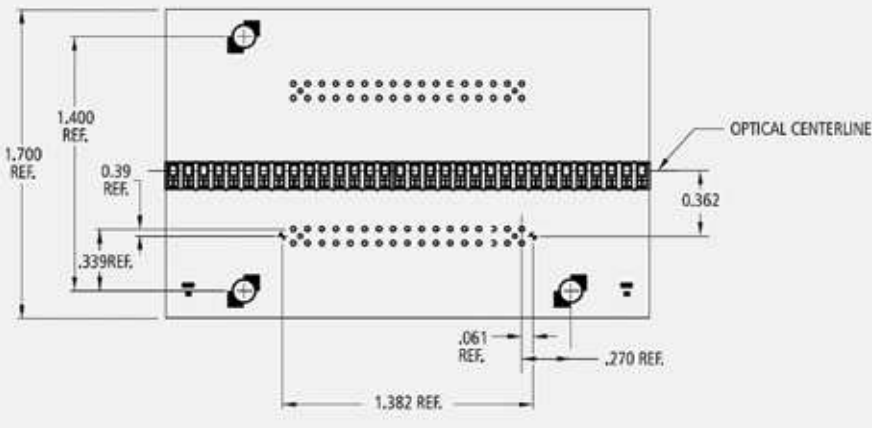
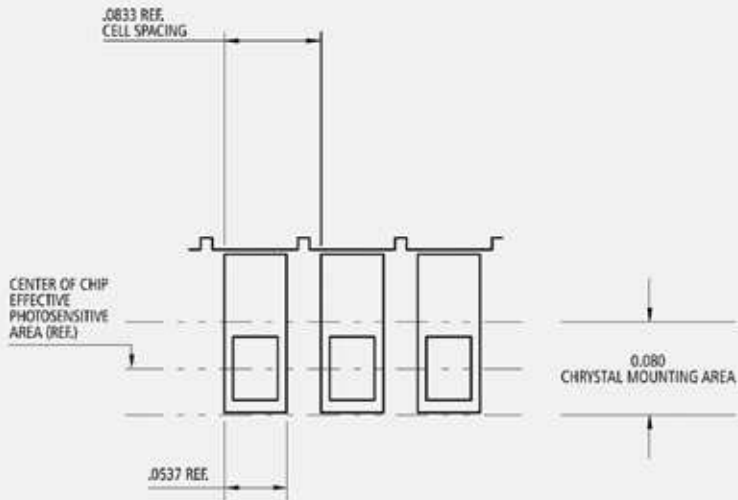

Figure 3

Chip Spacing Details, Side 1 (Typ) VTA2164H-D

Photosensitive Area 0.0545" x 0.0385 (Typ.) or 0.0021 SQ. IN.



Pin Out VTA2164H-D

Connector J1 (Top Diodes)		Connector J2 (Bottom Diodes)	
Pin	Connection	Pin	Connection
1	D1	1	D1
2	D2	2	D2
3	D3	3	D3
4	D4	4	D4
5	D5	5	D5
6	D6	6	D6
7	D7	7	D7
8	D8	8	D8
9	D9	9	D9
10	D10	10	D10
11	D11	11	D11
12	D12	12	D12
13	D13	13	D13
14	D14	14	D14
15	D15	15	D15
16	D16	16	D16
17	D17	17	D17
18	D18	18	D18
19	D19	19	D19
20	D20	20	D20
21	D21	21	D21
22	D22	22	D22
23	D23	23	D23
24	D24	24	D24
25	D25	25	D25
26	D26	26	D26
27	D27	27	D27
28	D28	28	D28
29	D29	29	D29
30	D30	30	D30
31	D31	31	D31
32	D32	32	D32
33	N/C	33	N/C
34	Common	34	Common

Figure 4

Pos. of Top Diodes Rel. to Bottom Diodes VTA2164H-D

(Optical Center Line to Optical Center Line)

