



Chipsmall Limited consists of a professional team with an average of over 10 year of expertise in the distribution of electronic components. Based in Hongkong, we have already established firm and mutual-benefit business relationships with customers from,Europe,America and south Asia,supplying obsolete and hard-to-find components to meet their specific needs.

With the principle of “Quality Parts,Customers Priority,Honest Operation,and Considerate Service”,our business mainly focus on the distribution of electronic components. Line cards we deal with include Microchip,ALPS,ROHM,Xilinx,Pulse,ON,Everlight and Freescale. Main products comprise IC,Modules,Potentiometer,IC Socket,Relay,Connector.Our parts cover such applications as commercial,industrial, and automotives areas.

We are looking forward to setting up business relationship with you and hope to provide you with the best service and solution. Let us make a better world for our industry!



## Contact us

Tel: +86-755-8981 8866 Fax: +86-755-8427 6832

Email & Skype: info@chipsmall.com Web: www.chipsmall.com

Address: A1208, Overseas Decoration Building, #122 Zhenhua RD., Futian, Shenzhen, China



# RMPA5255

## 4.9–5.9 GHz WLAN Linear Power Amplifier Module

### Features

- Full 4.9 to 5.9 GHz operation
- 34 dB small signal gain
- 230 mA total current at 18 dBm modulated power out
- 2.3% EVM at 18 dBm modulated power out
- 3.3 V collector supply voltage
- Integrated power detector with 20 dB dynamic range
- RoHS compliant 5 x 5 x 1.5 mm leadless package
- Internally matched to 50Ω and DC blocked RF input/output
- Internal DC bias de-coupling
- Optimized for use in 802.11a applications

### Description

The RMPA5255 power amplifier module is designed for high performance WLAN applications in the 4.9–5.9 GHz frequency band. The 10 pin, 5 x 5 x 1.5 mm package with internal matching on both input and output to 50Ω, and internal bias network components, allow for extremely simplified integration. An on-chip detector provides power sensing capability. The PA's low power consumption and excellent linearity are achieved using our InGaP Heterojunction Bipolar Transistor (HBT) technology.

### Device



### Electrical Characteristics<sup>1</sup> 802.11a OFDM Modulation

(176 μs burst time, 100 μs idle time) 54 Mbps Data Rate, 16.7 MHz Bandwidth

Parameter	Min	Typ	Max	Units
Frequency	4.9		5.9	GHz
Collector Supply Voltage	3.0	3.3	3.6	V
Mirror Supply Voltage		2.9		V
Mirror Supply Current		26		mA
Gain		33		dB
Total Current @ 18dBm Pout		230		mA
EVM @ 18dBm Pout <sup>2</sup>		2.3		%
Detector Output @ 18dBm Pout		450		mV
Detector Threshold <sup>3</sup>		5		dBm

#### Notes:

1. VCC = 3.3V, VPC = 2.9V, T<sub>A</sub> = 25°C, PA is constantly biased, 50Ω system.
2. Percentage includes system noise floor of EVM = 0.8%.
3. P<sub>OUT</sub> measured at P<sub>IN</sub> corresponding to power detection threshold.

### Electrical Characteristics<sup>1</sup> Single Tone

Parameter	Min	Typ	Max	Units
Frequency	4.9		5.9	GHz
Supply Voltage (VCC)	3.0	3.3	3.6	V
Power Control Voltage (VPC)	2.6	2.9	3.1	V
Gain		33.5		dB
Total Quiescent Current		160		mA
Bias Current at pin VPC <sup>2</sup>		26		mA
P1dB Compression		26		dBm
Current @ P1dB Compression		508		mA
Shutdown Current (VPC = 0V)		<1.0		μA
Input Return Loss		12		dB
Output Return Loss		20		dB
Detector Output at P1dB Compression		1.1		V
Detector Pout Threshold <sup>4</sup>		5		V
Turn-On Time <sup>3</sup>		<1.0		μS

**Notes:**

1. VCC = 3.3V, VPC = 2.9V, T<sub>A</sub> = 25°C, PA is constantly biased, 50Ω system.
2. Power Control bias current is included in the total quiescent current.
3. Measured from Device On signal turn on, (Logic Low) to the point where RF P<sub>OUT</sub> stabilizes to 0.5dB.
4. P<sub>OUT</sub> measured at P<sub>IN</sub> corresponding to power detection threshold.

### Functional Block Diagram

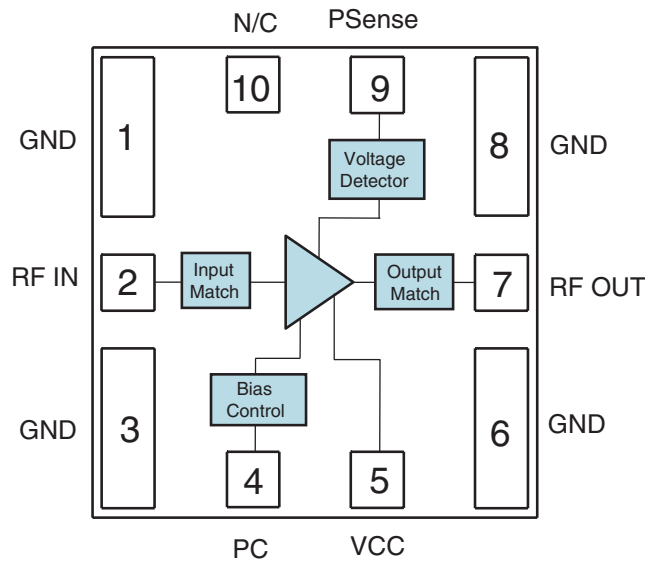



## Performance Data

### 802.11a OFDM Modulation

(176 ms burst time, 100 ms idle time) 54 Mbps Data Rate, 16.7 MHz Bandwidth

**RMPA5255 EVM vs. Modulated Pout**  
VCC=3.3V, VPC=2.9V, T=25°C

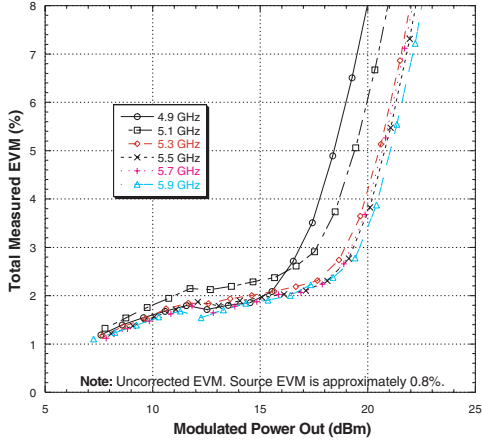

**RMPA5255 Gain vs. Modulated Pout**  
VCC=3.3V, VPC=2.9V, T=25°C

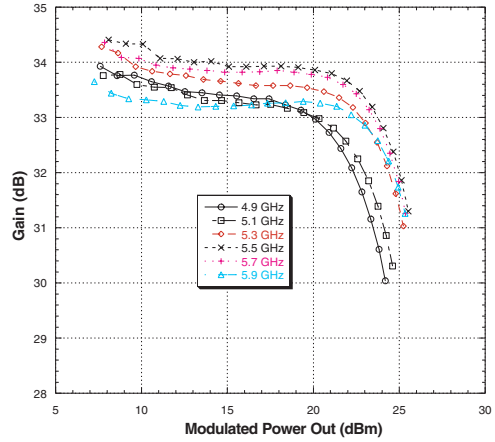

**RMPA5255 Total Current vs. Modulated Pout**  
VCC=3.3V, VPC=2.9V, T=25°C

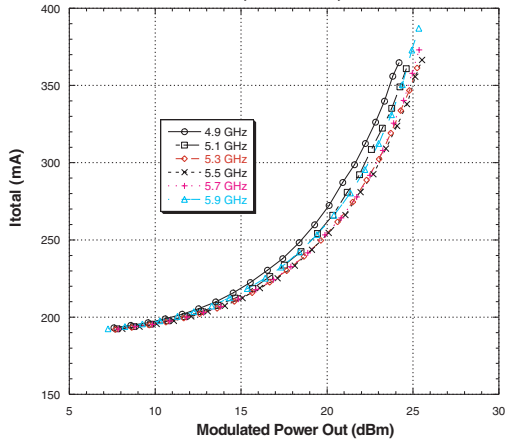

**RMPA5255 Detector Voltage vs. Modulated Pout**  
VCC=3.3V, VPC=2.9V, T=25°C

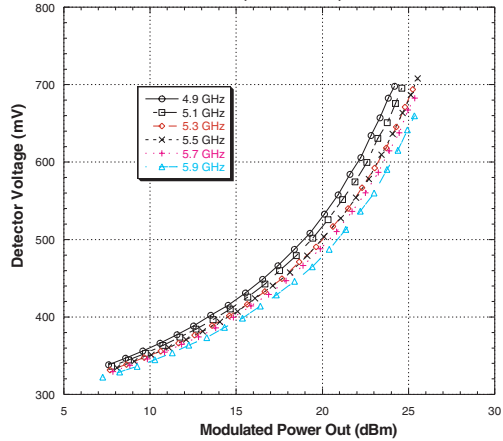

## Performance Data

### Single Tone

**RMPA5255 Gain vs. Single Tone Pout**  
VCC=3.3V, VPC=2.9V, T=25°C

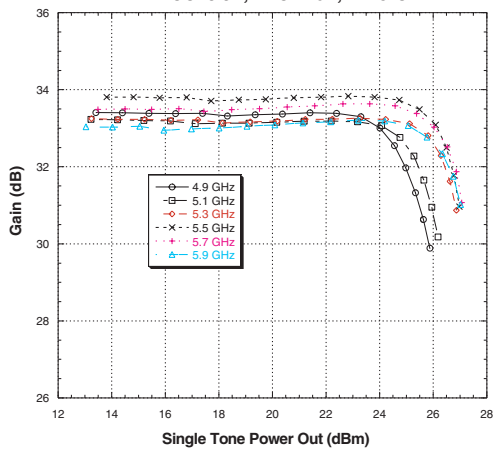

**RMPA5255 S-Parameters vs. Frequency**  
VCC=3.3V, VPC=2.9V, T=25°C

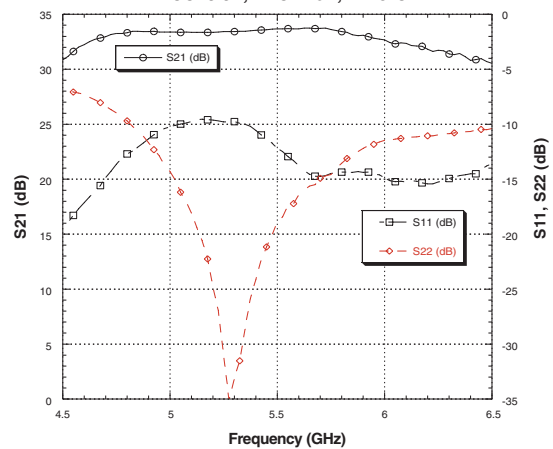

### Schematic

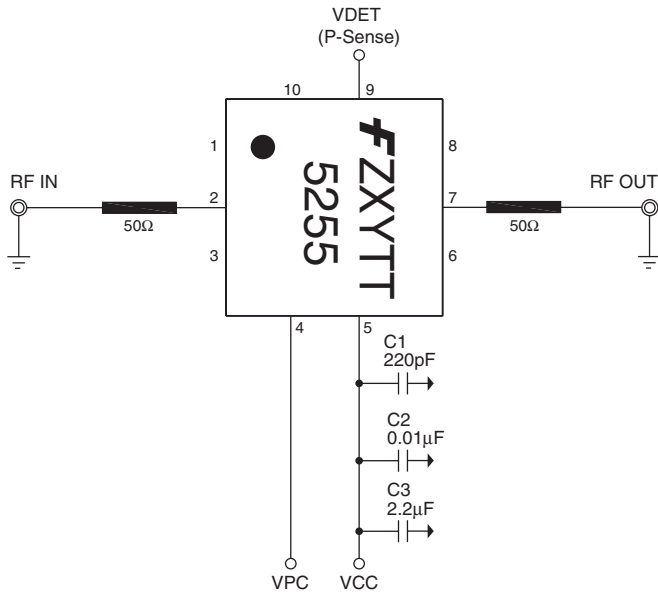

Pin	Description
1	GND
2	RF IN
3	GND
4	VPC
5	VCC
6	GND
7	RF OUT
8	GND
9	VDET (P-Sense)
10	N/C
11	CENTER GND

### Package Outline

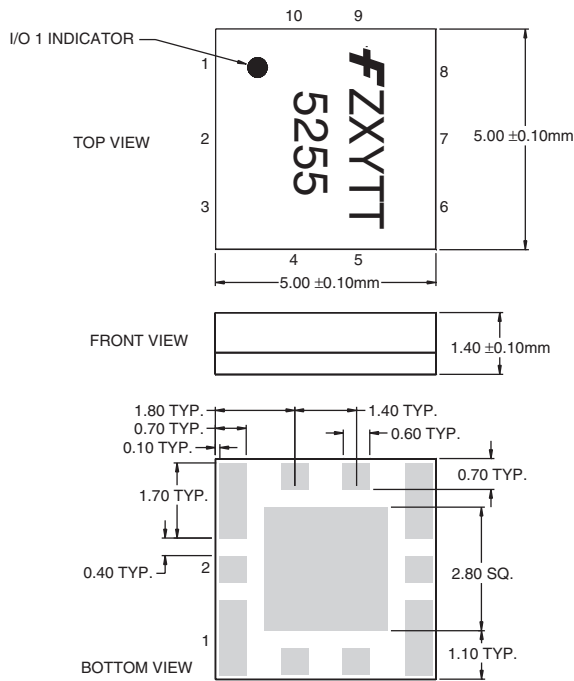

**NOTES:**

1. PACKAGE BASE MATERIAL AND INTERCONNECT METALLIZATION: BT GRADE CCL-HL832, AuNiCu, Au 0.38 MICROMETERS MINIMUM.
2. SMT EXPOSURE: THIS DEVICE WILL WITHSTAND EXPOSURE TO TEMPERATURES OF 240°C MAXIMUM FOR DWELL TIME OF 10 SECONDS MAXIMUM.

= EXPOSED METAL CONTACT PADS

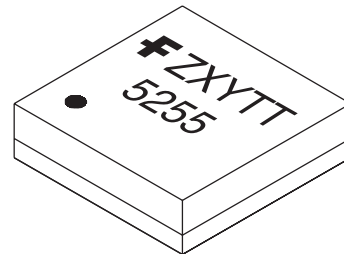

Dimensions in mm

## Evaluation Board Bill of Materials

### MATERIALS LIST

QTY	ITEM NO.	PART NUMBER	DESCRIPTION	VENDOR
1	1	F100035	PC, BOARD	FAIRCHILD
2	2	#142-0701-841	SMA CONNECTOR	JOHNSON
6	3	#2340-5211TN	TERMINALS	3M
REF	4	F100058	ASSEMBLY, RMPA5255	FAIRCHILD
1	5 (C1)	GRM1885C1H221JA01D	220 pF CAPACITOR (0603)	MURATA
1	6 (C2)	GMC10X7R103M25NT	0.01 uF CAPACITOR (0603)	MURATA
1	7 (C3)	GRM188R60J225KE01D	2.2 uF CAPACITOR (0603)	MURATA
A/R	8	SN63	SOLDER PASTE	INDIUM CORP
A/R	9	SN96	SOLDER PASTE	INDIUM CORP

## Evaluation Board Layout

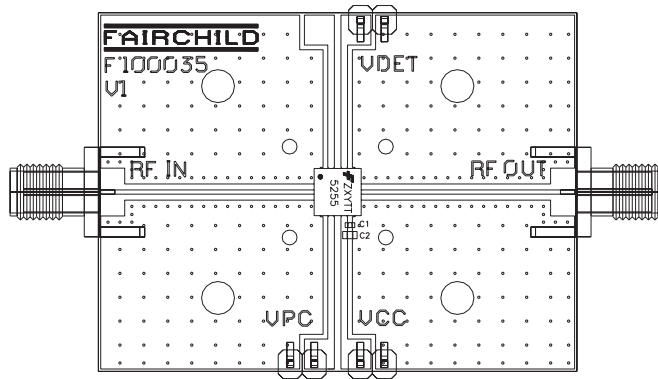

Actual Board Size = 2.0" X 1.5"

## Evaluation Board Turn-On Sequence<sup>1</sup>

### Recommended turn-on sequence:

- 1) Connect common ground terminal to the Ground (GND) pin on the board.
- 2) Connect voltmeter to VDET (P-Sense).
- 3) Apply positive supply voltage (3.3 V) to pin VCC (Collector voltage).
- 4) Apply positive bias voltage (2.9 V) to pin VPC (Power Control voltage).
- 5) At this point, you should expect to observe the following positive currents flowing into the pins:

Pin	Current
VCC	150 – 170 mA
VPC	21 – 31 mA

- 6) Apply input RF power to SMA connector pin RFIN. Current for pin VCC will vary depending on the input drive level.
- 7) Vary positive voltage VPC from +2.9 V to +0 V to shut down the amplifier or alter the power level. Shut down current flow into the pins:

Pin	Current
VCC	<1 nA

### Recommended turn-off sequence:

Use reverse order described in the turn-on sequence above.

#### Note:

1. Turn on sequence is not critical and it is not necessary to sequence power supplies in actual system level design.

## Applications Information

**CAUTION: THIS IS AN ESD SENSITIVE DEVICE.**

### Precautions to Avoid Permanent Device Damage:

- Cleanliness: Observe proper handling procedures to ensure clean devices and PCBs. Devices should remain in their original packaging until component placement to ensure no contamination or damage to RF, DC and ground contact areas.
- Device Cleaning: Standard board cleaning techniques should not present device problems provided that the boards are properly dried to remove solvents or water residues.
- Static Sensitivity: Follow ESD precautions to protect against ESD damage:
  - A properly grounded static-dissipative surface on which to place devices.
  - Static-dissipative floor or mat.
  - A properly grounded conductive wrist strap for each person to wear while handling devices.
- General Handling: Handle the package on the top with a vacuum collet or along the edges with a sharp pair of bent tweezers. Avoiding damaging the RF, DC, and ground contacts on the package bottom. Do not apply excessive pressure to the top of the lid.
- Device Storage: Devices are supplied in heat-sealed, moisture-barrier bags. In this condition, devices are protected and require no special storage conditions. Once the sealed bag has been opened, devices should be stored in a dry nitrogen environment.

### Device Usage:

Fairchild recommends the following procedures prior to assembly.

- Assemble the devices within 7 days of removal from the dry pack.
- During the 7-day period, the devices must be stored in an environment of less than 60% relative humidity and a maximum temperature of 30°C
- If the 7-day period or the environmental conditions have been exceeded, then the dry-bake procedure, at 125°C for 24 hours minimum, must be performed.

### Solder Materials & Temperature Profile:

Reflow soldering is the preferred method of SMT attachment. Hand soldering is not recommended.

### Reflow Profile

- Ramp-up: During this stage the solvents are evaporated from the solder paste. Care should be taken to prevent rapid oxidation (or paste slump) and solder bursts caused by violent solvent out-gassing. A maximum heating rate is 3°C/sec.
- Pre-heat/soak: The soak temperature stage serves two purposes; the flux is activated and the board and devices achieve a uniform temperature. The recommended soak condition is: 60-180 seconds at 150-200°C.
- Reflow Zone: If the temperature is too high, then devices may be damaged by mechanical stress due to thermal mismatch or there may be problems due to excessive solder oxidation. Excessive time at temperature can enhance the formation of inter-metallic compounds at the lead/board interface and may lead to early mechanical failure of the joint. Reflow must occur prior to the flux being completely driven off. The duration of peak reflow temperature should not exceed 20 seconds. Soldering temperatures should be in the range 255–260°C, with a maximum limit of 260°C.
- Cooling Zone: Steep thermal gradients may give rise to excessive thermal shock. However, rapid cooling promotes a finer grain structure and a more crack-resistant solder joint. The illustration below indicates the recommended soldering profile.

### Solder Joint Characteristics:

Proper operation of this device depends on a reliable void-free attachment of the heat sink to the PWB. The solder joint should be 95% void-free and be a consistent thickness.

### Rework Considerations:

Rework of a device attached to a board is limited to reflow of the solder with a heat gun. The device should be subjected to no more than 15°C above the solder melting temperature for no more than 5 seconds. No more than 2 rework operations should be performed.

## Recommended Solder Reflow Profile

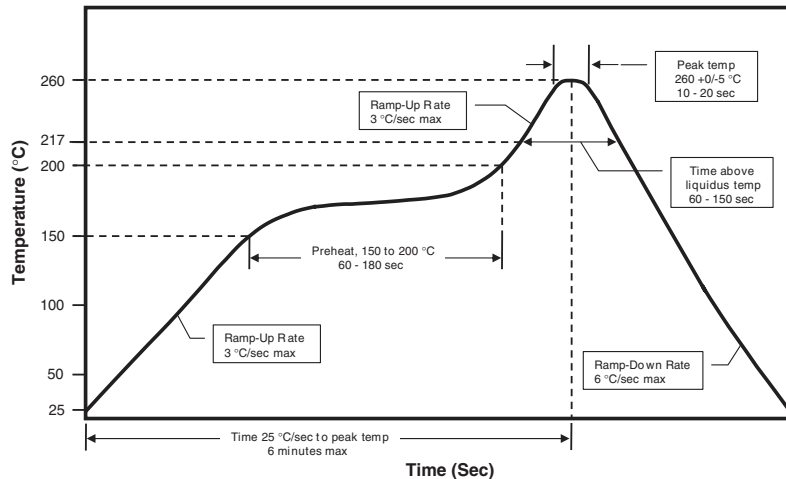

**TRADEMARKS**

The following are registered and unregistered trademarks Fairchild Semiconductor owns or is authorized to use and is not intended to be an exhaustive list of all such trademarks.

ACEx™	FAST®	ISOPLANAR™	PowerSaver™	SuperSOT™-8
ActiveArray™	FASTr™	LittleFET™	PowerTrench®	SyncFET™
Bottomless™	FPS™	MICROCOUPLER™	QFET®	TinyLogic®
Build it Now™	FRFET™	MicroFET™	QST™	TINYOPTO™
CoolFET™	GlobalOptoisolator™	MicroPak™	QT Optoelectronics™	TruTranslation™
CROSSVOLT™	GTO™	MICROWIRE™	Quiet Series™	UHC™
DOMET™	HiSeC™	MSX™	RapidConfigure™	UltraFET®
EcoSPARK™	I <sup>2</sup> C™	MSXPro™	RapidConnect™	UniFET™
E <sup>2</sup> CMOS™	i-Lo™	OCX™	µSerDes™	VCX™
EnSigna™	ImpliedDisconnect™	OCXPro™	SILENT SWITCHER®	Wire™
FACT™	IntelliMAX™	OPTOLOGIC®	SMART START™	
FACT Quiet Series™		OPTOPLANAR™	SPM™	
Across the board. Around the world.™		PACMAN™	Stealth™	
The Power Franchise®		POP™	SuperFET™	
Programmable Active Droop™		Power247™	SuperSOT™-3	
		PowerEdge™	SuperSOT™-6	

**DISCLAIMER**

FAIRCHILD SEMICONDUCTOR RESERVES THE RIGHT TO MAKE CHANGES WITHOUT FURTHER NOTICE TO ANY PRODUCTS HEREIN TO IMPROVE RELIABILITY, FUNCTION OR DESIGN. FAIRCHILD DOES NOT ASSUME ANY LIABILITY ARISING OUT OF THE APPLICATION OR USE OF ANY PRODUCT OR CIRCUIT DESCRIBED HEREIN; NEITHER DOES IT CONVEY ANY LICENSE UNDER ITS PATENT RIGHTS, NOR THE RIGHTS OF OTHERS.

**LIFE SUPPORT POLICY**

FAIRCHILD'S PRODUCTS ARE NOT AUTHORIZED FOR USE AS CRITICAL COMPONENTS IN LIFE SUPPORT DEVICES OR SYSTEMS WITHOUT THE EXPRESS WRITTEN APPROVAL OF FAIRCHILD SEMICONDUCTOR CORPORATION. As used herein:

- |                                                                                                                                                                                                                                                                                                                                                           |                                                                                                                                                                                                                                             |
|-----------------------------------------------------------------------------------------------------------------------------------------------------------------------------------------------------------------------------------------------------------------------------------------------------------------------------------------------------------|---------------------------------------------------------------------------------------------------------------------------------------------------------------------------------------------------------------------------------------------|
| <p>1. Life support devices or systems are devices or systems which, (a) are intended for surgical implant into the body, or (b) support or sustain life, or (c) whose failure to perform when properly used in accordance with instructions for use provided in the labeling, can be reasonably expected to result in significant injury to the user.</p> | <p>2. A critical component is any component of a life support device or system whose failure to perform can be reasonably expected to cause the failure of the life support device or system, or to affect its safety or effectiveness.</p> |
|-----------------------------------------------------------------------------------------------------------------------------------------------------------------------------------------------------------------------------------------------------------------------------------------------------------------------------------------------------------|---------------------------------------------------------------------------------------------------------------------------------------------------------------------------------------------------------------------------------------------|

**PRODUCT STATUS DEFINITIONS**

**Definition of Terms**

Datasheet Identification	Product Status	Definition
Advance Information	Formative or In Design	This datasheet contains the design specifications for product development. Specifications may change in any manner without notice.
Preliminary	First Production	This datasheet contains preliminary data, and supplementary data will be published at a later date. Fairchild Semiconductor reserves the right to make changes at any time without notice in order to improve design.
No Identification Needed	Full Production	This datasheet contains final specifications. Fairchild Semiconductor reserves the right to make changes at any time without notice in order to improve design.
Obsolete	Not In Production	This datasheet contains specifications on a product that has been discontinued by Fairchild semiconductor. The datasheet is printed for reference information only.

Rev. 116