



Chipsmall Limited consists of a professional team with an average of over 10 year of expertise in the distribution of electronic components. Based in Hongkong, we have already established firm and mutual-benefit business relationships with customers from,Europe,America and south Asia,supplying obsolete and hard-to-find components to meet their specific needs.

With the principle of "Quality Parts,Customers Priority,Honest Operation,and Considerate Service",our business mainly focus on the distribution of electronic components. Line cards we deal with include Microchip,ALPS,ROHM,Xilinx,Pulse,ON,Everlight and Freescale. Main products comprise IC,Modules,Potentiometer,IC Socket,Relay,Connector.Our parts cover such applications as commercial,industrial, and automotives areas.

We are looking forward to setting up business relationship with you and hope to provide you with the best service and solution. Let us make a better world for our industry!



Contact us

Tel: +86-755-8981 8866 Fax: +86-755-8427 6832

Email & Skype: info@chipsmall.com Web: www.chipsmall.com

Address: A1208, Overseas Decoration Building, #122 Zhenhua RD., Futian, Shenzhen, China





WiFLy RN-111B

802.11b “wifi” wireless LAN – OEM Module

Integration Guide and Users Manual

Version 1.25

June 19, 2009

Copyright © 2008 Roving Networks, Inc. All Rights Reserved.

The contents of this document can be changed by Roving networks without prior notice and do not constitute any binding undertakings from Roving networks. Roving networks is not responsible under any circumstances for direct, indirect, unexpected damage or consequent damage that is caused by this document.

Printed in the United States of America.

1. Contents

| | | |
|------|---|----|
| 2. | RN-111B Overview..... | 3 |
| 2.1. | RN-111B Features | 3 |
| 2.2. | RN-111B Options | 3 |
| 2.3. | RN-111B Specifications | 4 |
| 2.4. | RN-111B Block Diagram | 4 |
| 2.5. | RN-111B Electrical Characteristics..... | 5 |
| 2.6. | RN-111B Operating and Environmental Conditions..... | 5 |
| 2.7. | RN-111B Dimensions..... | 6 |
| 2.8. | RN-111B Pin Description..... | 6 |
| 3. | Introduction | 7 |
| 3.1. | Hardware Interface | 7 |
| 3.2. | Configuration..... | 8 |
| 3.3. | LED indications | 8 |
| 4. | WiFLY Command Reference..... | 9 |
| 4.1. | SET COMMANDS..... | 10 |
| 4.2. | GET COMMANDS..... | 13 |
| 4.3. | STATUS COMMANDS..... | 13 |
| 4.4. | ACTION COMMANDS..... | 14 |
| 4.5. | FILE IO COMMANDS | 14 |
| 5. | System timers and other features..... | 15 |
| 5.1. | Wake on Sensor INPUTs..... | 15 |
| 5.2. | Wake on UART | 16 |
| 5.3. | Uart Receiver, RTS/CTS Hardware Flow Control | 16 |
| 5.4. | Setting PIO directions, Disabling LED drivers | 16 |
| 5.5. | Alternate IO functions | 17 |
| 5.6. | 4.6 Setting Print levels..... | 17 |
| 6. | Making an Outbound Connection | 18 |
| 7. | FTP Upgrade and Image Storage | 19 |
| 8. | Security and Authentication Modes | 20 |
| 9. | Factory Default Power up Settings..... | 21 |

2. RN-111B Overview

The RN-111b “WiFly” radio module is a complete, stand alone, embedded wireless LAN access device. The device has on board TCP/IP stack and applications. Requiring only 4 pins (POWER, TX, RX, GND) to design in. Once initial configuration is set, the radio can automatically access the WiFi network and send/receive serial data over UART.

- Fully Qualified 2.4GHz IEEE 802.11b Wireless LAN radio module.
- 32bit CPU, 230K ROM, 80KRAM, 4MB on board flash.
- On board ECOS -OS, TCP/IP stacks.
- 3.3V UART and SPI interfaces available to various applications.
- Accepts wide voltage range input 3.3V – 12VDC.
- Multiple Antennae options, SMA, U.FL, ceramic Chip, ¼ wave wire.
- Conforms to FCC, CE and the EMI standard of each country.
- Modular Approval: FCC ID: T9J-RN111b, ICS: 6514A-RN111b, CE: 0681
- RoHS compliance.

2.1. RN-111B Features

- Baud rate speeds: 1200bps up to 921.6Kbps and non-standard baudrates.
- Ultra low power consumption (110mA TX, 40ma RX, 12uA deep sleep).
- Real time clock for timestamping, auto-sleep and auto-wake modes.
- UART local configuration using simple ASCII commands.
- Over the air firmware upgrade (FTP), and data file upload.
- 3 on board LEDs for status.
- 6 Programmable IO pins, 8 analog sensor inputs.
- On board flash can be used for secondary applications,data logging, and stored data forwarding at intervals to the network.
- Small-form factor low profile radio modem 25mm x 36mm x 5mm.
- 32 pin Standard 2mm DIP socket pin spacing.

2.2. RN-111B Options

- Larger flash memory (up to 16Mb) for data logging.
- On board boost regulator can power from low voltage 2-3V battery source.
- SMA, Chip, U.FL or wire ANT.

2.3. RN-111B Specifications

| Item | Specifications |
|----------------------------------|---|
| Frequency | 2402 ~ 2480MHz |
| Modulation | DSSS(CCK-11, CCK-5.5, DQPSK-2, DBPSK-1) |
| Channel intervals | 5MHz |
| Number of channels | 13CH |
| Transmission rate (over the air) | 11/5.5/2/1 Mbps |
| Receive sensitivity | -85dBm typ. |
| Output level (Class1) | 12dBm max. |
| Dimensions | |
| | With antenna |

2.4. RN-111B Block Diagram

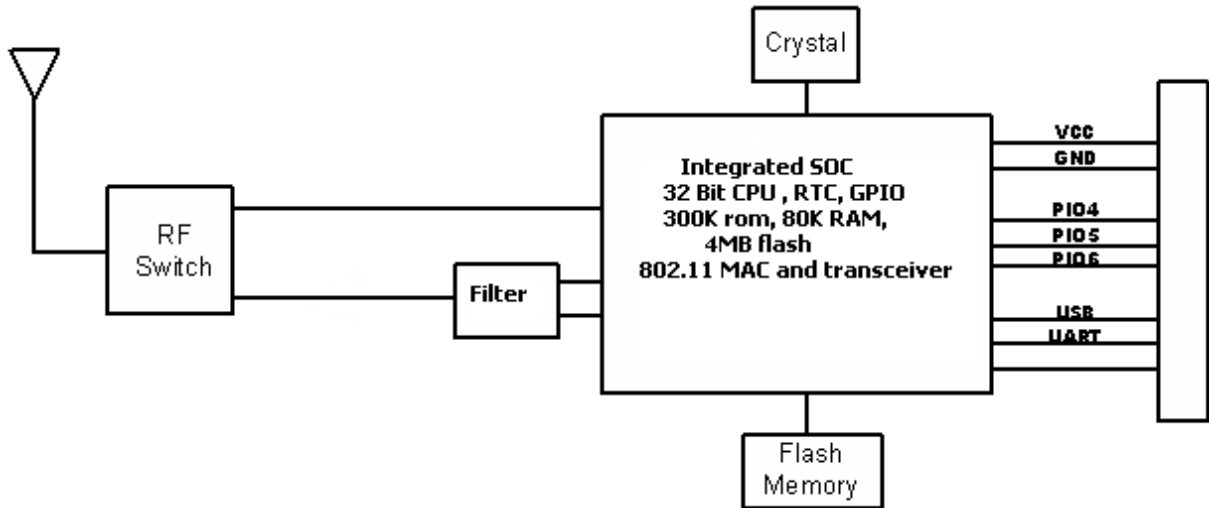

2.5. RN-111B Electrical Characteristics

| | Min | Typ. | Max. | Unit |
|----------------------------------|-----|------|------|------------|
| Supply Voltage VIN | 4.0 | 5.0 | 12 | VDC |
| Supply Voltage VDD | 3.0 | 3.3 | 3.6 | VDC |
| Supply Voltage (VBATT option) | 2.0 | 3.0 | 3.3 | VDC |
| Average power consumption | | | | |
| Standby/Idle (default settings) | - | 35 | - | mA |
| Sleep | 10 | 12 | 15 | uA (micro) |
| Connected(idle, RX) | | 40 | | mA |
| Connected(TX) | | 110 | 180 | mA |

2.6. RN-111B Operating and Environmental Conditions

| | |
|-------------------------------|----------------|
| Operating Temperature Range | -40 °C ~ 85 °C |
| Storage Temperature Range | -40 °C ~ 85 °C |
| Relative Humidity (Operating) | ≤90% |
| Relative Humidity (Storage) | ≤90% |

2.7. RN-111B Dimensions

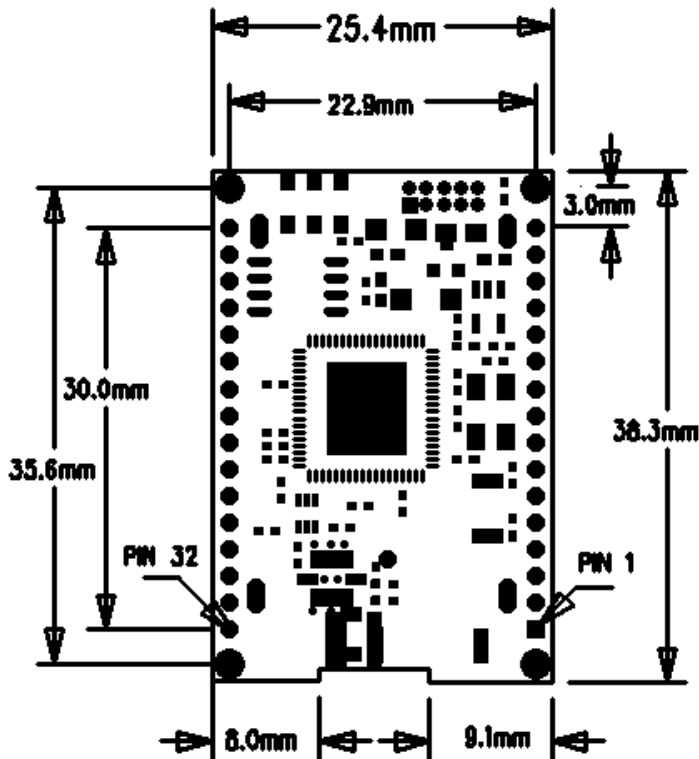

2.8. RN-111B Pin Description

| Pin | Pin Name | Pin | Pin Name |
|-----|------------------------|-----|---------------------|
| 1 | NO CONNECT | 32 | GND |
| 2 | VDD_SW (NO CONNECT) | 31 | SENSE-1 (WAKE GPIO) |
| 3 | SENSE-5 | 30 | SENSE-2 (WAKE GPIO) |
| 4 | SENSE-6 | 29 | SENSE-3 (WAKE GPIO) |
| 5 | SENSE-7 | 28 | SENSE-4 (WAKE GPIO) |
| 6 | SENSE-8 | 27 | TX – data output |
| 7 | PIO6 (RED LED) | 26 | RX – data input |
| 8 | PIO9 (factory reset) | 25 | CTS (PIO2) input |
| 9 | NO CONNECT | 24 | RTS (PIO3) output |
| 10 | NO CONNECT | 23 | PIO4 (GREEN LED) |
| 11 | RESET* (active LOW) | 22 | PIO5 (YELLOW LED) |
| 12 | SHUTDOWN (NO CONNECT) | 21 | SPI_MI |
| 13 | VIN (3.6-16VDC) | 20 | SPI_CS |
| 14 | VREG (3.3V LDO output) | 19 | SPI_CK |
| 15 | VBATT (TIE to VREG) | 18 | SPI_MO |
| 16 | GND | 17 | VDD (3.3V) |

*** NOTE: Any unused pins should be left floating.

3. Introduction

Scope

This Integration and Users Guide, along with the [RN-111b](#) module have been developed to assist users in embedding Wifi technology into their serial, SPI, and sensor devices. The goal is to make the implementation of embedded Wifi wireless networks as seamless and easy as possible. This document will explain how to setup and establish communications between the [RN-111b](#) and Wifi enabled networks for data applications.

3.1. Hardware Interface

There are 3 options to power the RN-111b.

1. Supply 3.6 to 16VDC power to VIN (pin 13). Tie VREG (pin 14) to VBATT(pin 15).
2. Apply 3.3VDC regulated power to VDD (pin 17).
3. Apply battery = 2.0 to 3.0Vdc to VBATT (pin 15).

If VIN is powered, VREG will supply 3.3VDC output and can be used for other circuits, with a current limitation of 50 ma.

Reset is active LOW, is optional and does not need to be connected. There is a built in voltage monitor that will pull Reset LOW (open drain FET) if the input voltage drops below 2.7VDC. If external reset is desired, use an OPEN DRAIN driver and do not drive the Reset pin to any voltage > 1.0 Vdc.

Warning: Do NOT exceed the voltage ratings on the 3.3V pins, damage to the module will result.

Important Notes:

#1: RESET input is a low voltage (1.2VDC) input, with a 10K pullup and built in power monitor circuits. If external reset is desired, use pull down (open drain or collector) only.

#2: The Sensor inputs SENS1-7 are extremely sensitive to over voltage. Under no conditions should these pins be pulled high above 1.2VDC. Placing any voltage above this will permanently damage the radio module and render it useless.

#3: Placing 5VDC or any voltage above 3.3Vdc into the VDD pins of the module will permanently damage the radio module. Be sure to use the VIN = pin 13 power pin for any power supplied that is > 3.3VDC.

#4: Placing 3.3Vdc into the PIO's while they are set as outputs will permanently damage the radio modules. The failure mode is a short across GND and VCC. Use a 10KΩ resistor in series or a 10KΩ pull up resistor for input and output PIO's respectively.

- Connect a common ground when using the external TX, RX inputs.
- For a 3 wire DB-9 interface (tx, rx, gnd only) connect/short CTS to RTS, Factory default is hardware flow control disabled, CTS and RTS not connected.
- When using a 5.0Vdc Input, PIO's require a 10K ohm series resistor. PIO's are 0-3.3Vdc not 5 volt tolerant.

3.2. Configuration

Command Mode (vs Normal Data mode)- Upon powerup, the device will be in data mode. To enter command mode, The characters "\$\$\$" must be sent. The device will respond with "CMD". To exit command mode, send "exit<cr>". The device will respond with "EXIT". Parameters, such as the SSid, Channel, IP address, Serial Port settings, and all other settings can be viewed and configured. While in command mode, the device will accept ASCII bytes as commands.

When passing ASCII characters through UART interface of the **RN-111b**, The communications settings of your device or terminal should match the settings of the **RN-111b** which default to 9600bps, 8 bits, No Parity, 1 stop bit, and hardware flow control disabled.

Run your favorite terminal emulator, Roving Networks provides a free one, Teraterm, at <http://www.rovingnetworks.com/support/teraterm.zip>.

Type "\$\$\$" on your emulator. You should see "CMD" returned to you. This will verify that your cable and comm. settings are correct. Most valid commands will return an "AOK", response, and invalid ones will return an Error description.

Commands that are not recognized will return a "ERROR: Unknown Cmd".

To exit command mode, type "exit"<cr>.

NOTE1 :

You can enter command mode locally over the serial port at any time when not connected, and also when connected if the appropriate settings are enabled.

3.3. LED indications

| Condition | GREEN | YELLOW | RED LED |
|------------|--------------------|---------------------|-----------------------------|
| ON Solid | CONNECTED over TCP | | NOT ASSOCIATED |
| Fast BLink | NO IP ADDRESS | WiFi Receive Packet | |
| Slow Blink | IP ADDRESS OK | | ASSOCIATED, but no Internet |
| OFF | NO power | | ASSOCIATED and Internet OK |

4. WiFLY Command Reference

The commands begin with a keyword, and have optional additional parameters, generally space delimited. Commands and options **are** case sensitive. hex input data can be upper or lower case. String text data, such as SSID, are also case sensitive.

The first keyword is fully decoded, and the optional parameters can be short-formed.

For example,

set uart baudrate 115200 is valid,

set uart b 115200 is also valid,

set u b 115200 is also valid, however,

s uart baudrate 115200 is NOT valid.

ENTERING VALUES

Numbers can be entered as either decimal, (like 115200 above) or HEX. To enter HEX, use **0x<value>**. For example, the HEX value FF would be entered as 0xFF.

Commands fall into 5 general categories:

SET COMMANDS -Take effect immediately, permanently (save command issued).

GET COMMANDS -Retrieve the permanently stored information for display to user.

STATUS COMMANDS -See what is going on with the interface, IP status, etc.

ACTION COMMANDS- Perform action such as scan, connect, disconnect, etc.

FILE IO COMMANDS - Upgrade, load and save configuration, delete files, etc.

IMPORTANT: HOW CONFIGURATION WORKS

When the system boots, all configuration data is loaded into RAM variables from the file called "config". The set commands actually only modify the RAM copy of variables in the system. This allows temporary change of parameters "on the fly" to test features, minimizes power usage and saves on flash re-write cycles.

Once all configuration is complete, the user should be sure to use the [save](#) command to store the configuration data, otherwise it will not take effect upon reboot or reset. Multiple configurations can be stored by using the [save <filename>](#) command, and these configurations can be loaded using the [load <filename>](#) command. These files can be upload to remote FTP site, such that once a desired configuration is created, it can quickly be copied into additional devices (cloning).

4.1. SET COMMANDS

These commands begin with "set". There are 6 major categories.

1. **COMM** - communication and data transfer, timers, matching chars.
2. **IP** - IP settings.
3. **SYS** - system settings such as sleep and wake timers.
4. **TIME** - timer server settings.
5. **UART** - serial port settings such as baudrate and parity.
6. **WLAN** - wireless interface settings, such as ssid, chan, and security options.

COMM PARAMETERS – TCP connection status strings

set comm close <string> sets the string to send locally when the port is closed.

If no string is desired, use the command **set comm close** (without the parameter)

set comm open <string> sets the string to send locally when the port is opened.

set comm remote <string> sets the number of bytes to receive before forwarding.

COMM PARAMETERS – receive data forwarding

set comm idle <secs> sets the idle disconnect timer in seconds, causes disconnect if no transmit or receive data is seen.

set comm match <value> sets the decimal value of the matching character to search for to initiate forwarding. 0 disables.

set comm size <value> sets the number of bytes to receive before forwarding
0-1 forwards immediately. maximum value = 255 bytes.

set comm time <num *10ms> sets the number of 10 millisecond intervals after a byte is received to begin forwarding data. 0 disables.

IP PARAMETERS

set ip address <addr> sets the IP address. Numbers are SPACE delimited.

Example : "set ip a 10 10 10 2"

set ip dhcp <0,1> Enable or disable DHCP client.

set ip gateway <addr> sets the gateway address.

set ip host <addr> sets the remote host address.

set ip backup <addr> sets a secondary host address.

set ip localport <num> sets the local port number.

set ip netmask <value> sets the netmask.

set ip protocol <0,1,2,3> sets the protocol. 0=UDP, 1=TCP client, 2=TCP server, 3=UDP server.

set ip remote <value> sets the remote host port number.

set ip ftp <addr> sets the ftp server address.

set ip uport <num> sets the ftp server port number.

SYSTEM PARAMETERS

set sys autoconn <secs> TCP mode: sets the auto-connect TCP timer. 0 disables.

set sys autosleep <num *10ms> UDP mode: sets the auto-sleep timer. 0 disables.

set sys iofunc <value> sets the IO port alternate functions. Bit-mapped value.

set sys mask <mask> sets the IO port direction mask. Bit-mapped value.

set sys printlvl <value> sets numerous print functions. Bit-mapped value.

set sys output <value> <mask> sets output PIO pins to HIGH or LOW.
Bit-mapped value. Optional mask only sets a subset of pins.

set sys sleep <secs> sets the sleep timer. 0 disables.

set sys trigger <value> sets the sensor input to wake on (1-4). 0 disables.

set sys wake <secs> sets the auto wake timer. 0 disables.

TIME SERVER PARAMETERS

set time address <addr> sets the time server address. This is also the server address for UDP packet mode.

set time port <num> sets the time server port number.

set time enable <0,1,2> Enable or disable time server. 1= get time on powerup. 2=get time continuously every 60 seconds.

UART PARAMETERS

set uart parity <n,e,o> sets the UART parity.

Example : "set u p e" sets even parity

set uart baud <rate> {1200, 2400, 4800, 9600, 19200, 38400, 57600, 115200, 230400, 460800, 921600 }.

Example : "set u b 9600" sets the baudrate to 9600 baud.

set uart raw <rate> sets a RAW uart value. Used to set non-standard rates.

www.rovingnetworks.com

support@rovingnetworks.com
Phone 408-395-6539

Example : "set u r 760" sets the baudrate to 7200 baud.

set uart flow <0,1> sets the flow control mode. 0=off, 1= hardware RTS/CTS.

set uart tx <0, 1> Disables or enables the TX pin= PIO0 of the UART. Disable will set PIO0 to an INPUT with weak pulldown.

WLAN PARAMETERS

set wlan auth <value> sets the authentication level. 0= disabled, 1=WPA-PSK, 2=WPA2-PSK, 3=WEP-128.

set wlan channel <value> sets the wlan channel, 1-13 is the valid range for a fixed channel. If 0 is set, then a probe scan is performed, using the ssid, for all the channels set in the channel mask.

set wlan key <num> <value> sets the WEP key. key must be

EXACTLY 13 bytes (26 ASCII chars). Data is expected in HEX format, "0x" should NOT be used here.

Example : "set w k 112233445566778899AABBCCDD"

Hex digits > 9 can be either upper or lower case.

set wlan mask <value> sets the wlan channel mask, bit-mapped value. Bit 0 = ch 1.

set wlan num <value> sets the default WEP key to use. 1-4 is the valid range.

Example : "set w n 2" sets the default key to 2.

set wlan phrase <string> sets the passphrase for WPA security modes. 1-64 chars. The passphrase can be alpha and numeric, and is used along with the ssid to generate a unique 32 byte Pre-shared key (PSK), which is then hashed into a 256 bit number.

However, if exactly 64 chars are entered, it is assumed that this entry is already an ASCII HEX representation of the 32 byte PSK and no such processing is done.

Example : "set w p password" sets the phrase.

set wlan ssid <string> sets the wlan ssid to associate with. 1-32 chars.

set wlan rate <value> sets the preferred wlan data rate. Default = 1. Valid settings are: 1 = 1Mbit, 2 = 2Mbit, 4=5Mbit, 8 = 11Mbit. Note that the effective range will be reduced as the datarate is increased.

set wlan window <value> sets the TCP max. buffer size. Default is 1460 bytes.

4.2. GET COMMANDS

These commands begin with "get". They represent the stored values as configured.

- get com** display comm. settings.
- get ip** display IP address and port number settings.
- get mac** display the device MAC address.
- get port** return current value of the PIO pins in hex format.
- get sys** display system settings, sleep, wake timers, etc.
- get time** display the time server UDP address and port number.
- get wlan** display the ssid, chan, and other wlan settings.
- get uart** display the UART settings.

In addition to the above, there are a few other useful commands available.

- ver** return the software release version

4.3. STATUS COMMANDS

These commands begin with "show", and they return the current values of variables in the system. In some cases, for example IP addresses, the current values are received from the network, and may not match the stored values.

- show net** Displays current network status, association, authentication, etc.
- show rssi** Displays current last received signal strength.
- show stats** Displays current statistics, packet rx/tx counters, etc.
- show time** Displays number of seconds since last powerup or reboot
- show i** Displays IO pin levels status in this HEX format: 8ABC

Example: show I returns 8103 indicates pins 0, 1 and 9 high level.

- show c** Displays connection status in this HEX format: 8XYZ

| | | | | | | | |
|----------|-------|---------|------------|--------------|--------|-------|---|
| Bit loc | 13-16 | 9-12 | 7 | 6 | 5 | 4 | 0-3 |
| function | fixed | channel | DNS found | DNS server | Authen | Assoc | TCP status |
| value | 8 | 1-13 | 1=resolved | 1= contacted | 1= OK | 1=OK | 0= Idle, 1=Connected 3= NOIP 4= Connecting |

4.4. ACTION COMMANDS

- \$\$\$** Enter command mode Characters are PASSED until this exact sequence is seen. If any bytes are seen before these chars, or after these chars, in a 1 second window, command mode will not be entered and these bytes will be passed on to other side.
- close** Disconnect a TCP connection.
- exit** Exit command mode. Exit command mode. "EXIT" will be displayed.
- open** TCP connect. The device will attempt to connect to the remote stored address and port number.
- Ping <g,ip adr> <num>** Ping remote host. Default sends 1 packet. Optional <num> sends <num> pings at 10 pings per second. Use "Ping 0" to terminate a ping command.
- ping g pings the gateway.
- reboot** Forces a reboot of the device (similar to power cycle)
- scan <time> <active>** Performs an active probe scan of access points on all 13 channels, and prints out MAC address, receive signal strength, and SSID name. Optional <time> in ms to scan per channel, default = 200ms. If the <active> option is set = 0, passive scan is performed. This command will cause the device to disassociate if it is connected to an AP, and the user should reboot the device once scanning is complete.
- time** Sends a UDP time server request packet out.

4.5. FILE IO COMMANDS

- del <name> <num>** deletes a file. Optional <num> will override the name and use the sector number shown in the "ls" command.
- load <name>** reads in a new config file.
- ls** Displays the files in the system
- save** Saves the configuration to "config" (the default file).
- save <name>** Saves the configuration data to a new file name
- set boot <file#>** Makes file# the new boot image.
- set factory 1** Loads factory defaults into the RAM configuration.
- ftp get <name>** Retrieves a file from the remote FTP server. If <name> not specified, the default "wifly.img" filename is used.
- ftp update <name>** Deletes the backup image, retrieves new image and updates the boot image.

5. System timers and other features

There are 2 timers that can be used to put the module to sleep, and perform a wake up. If the sleep timer is enabled, the module will automatically go into low power mode after the timer counts down to 0. The countdown is disabled if the module has an IP connection, or the module is in COMMAND mode. The timer is reset when characters are received on the UART.

The sleep timer is set with : **set sys sleep <time>** time=decimal in seconds.

The wake timer is set with: **set sys wake <time>** time=decimal in seconds.

UDP sleep, and Connection timers

There is another timer than can be used to put the device to sleep.

In UDP protocol mode, the auto-conn timer is re-defined as an auto-sleep timer.

Upon the start of transmission of the first UDP data packet this timer will count down.

set sys autosleep <value> UDP mode: sets the auto-sleep timer. 0 disables

the timer is decremented every 10 milliseconds. Because the timer is asynchronous, the actual value can vary by 10ms. Using a minimum value of 2 is recommended to ensure that the UDP packet gets transmitted. For larger packets the value should be increased.

In TCP-Client mode, the auto-conn timer is used as a connect out timer. If set, the device will automatically attempt a connection when the timer expires.

set sys autoconn <secs>

In TCP-Client AND TCP-Server mode, there is also a disconnect timer.

set comm idle <secs> sets the idle disconnect timer. This causes a disconnect if no transmit or receive data is seen.

5.1. Wake on Sensor INPUTs

There are 4 inputs available to wake the module from sleep, SENS1-4.

To enable 1 of these inputs, use: **set sys trigger <0,1,2,3,4>**. 0 disables.

Only the **SENS1** input has a resistor divider (24K in series with 10K to GROUND) which allows this pin to tolerate 3V logic. The other sensor pins DO NOT, so care must be taken.

WARNING: Under no conditions should the voltage on any SENS2-8 input exceed 1.2VDC. Permanent damage to the module will result.

The SENS1-4 inputs have a small current source that is activated in sleep mode. This source is approximately 100nA, and will cause the input to float up to about 1.2VDC. IF SENSE1 for example, is enabled, pulling the SENS1 pin to GROUND will wake the device. An open drain FET is a good device to tie to the pin. The threshold is about 500mV. Additional

pullup to 1.2VDC may need be used if the circuit has an impedance (due to leakage current) of less than 5Mohms (500mv / 100nA). SENS1-4 pins that are not used should be left unconnected.

5.2. Wake on UART

When the module is in Sleep mode, the UART itself is disabled. However, wake on UART can be accomplished by connecting the SENS1 pin to the RX data pin.

To enable or disable this function, use: **set sys trig 1**.

It should be noted that the first byte sent into the module will likely be lost, so the designer should take care to send a preamble byte to wake up the module before sending valid data bytes.

5.3. Uart Receiver, RTS/CTS Hardware Flow Control

The UART receive buffer is approx. 1024 bytes, and at lower baudrates (9600, 19200) the system can process data into the device without need for flow control.

If constant streaming of data into RX on the device is required, care should be taken to set the comm parameters to optimize the performance. If data has a termination char, this can be used. Also, if data has a particular frame size, this can be used.

set comm match <value> sets the value of the packet terminator.

set comm size <value> sets the number of bytes to receive before forwarding
0-1 forwards immediately. maximum value = 255 bytes.

The **comm size** is automatically set whenever the baudrate is set, but should be modified if needed.

Even at higher baudrates (115K and higher) it is possible to operate without flow control if packets are uniform and a protocol is used to ensure that data is delivered on the remote side before the next packet is sent.

However, given the uncertainty of packet delays in a TCP/IP network and the affects of loss and retries inherent in wireless networks, flow control is usually required to guarantee no data is lost.

GPIO 2 and 3 implement UART hardware flow control if enabled.

By default flow control is disabled. To enable hardware flow control, use **set uart flow 1**.

5.4. Setting PIO directions, Disabling LED drivers

The table below shows the usage of the PIO pins and their default values:

Use the command: **set sys mask <hex val>** to enable or disable certain pins as outputs.

www.rovingnetworks.com

support@rovingnetworks.com
Phone 408-395-6539

For example, **set sys mask 0** will default all pins to INPUT.

Note that PIO 7, and 8 are used internally by the module and cannot be changed. Setting or clearing bits in these locations will be ignored.

| PIO | State | DESCRIPTION |
|-----|--------|---|
| 9 | input | Used for factory reset |
| 8,7 | NA | Not available |
| 6 | output | RED LED- (Associated, internet OK/ TCP conn) |
| 5 | output | YELLOW LED - (wifi RX or RSSI) |
| 4 | output | GREEN LED - (system status /ASSOC-AUTH) |
| 3 | output | UART RTS - goes HIGH on POWERUP, LOW once system is READY. If HW Flow control enabled, toggles HIGH to indicate RX buffer full. |
| 2 | input | UART CTS - throttles transmitter if HW flow control enabled. LOW enables transmitter, HIGH will disable. |
| 1 | input | UART RX |
| 0 | output | UART TX |

5.5. Alternate IO functions

There are a number of alternate IO functions that can be enabled. These functions override the default IO function given in section 4.4, and described in the LED table of section 2.3. If no bits are set for a particular PIO pin, that pin is available to be used as general purpose input or output, based on the IOMASK setting.

set sys iofunc <value> sets numerous alternate functions. Bit-mapped value.

| Bit | Function |
|-----|--|
| 0 | PIO4 - Output. HIGH once associated/authenticated and have IP address. |
| 1 | PIO5 - Input. Set HIGH to trigger TCP connection, LOW to disconnect. |
| 2 | PIO6 - Output. HIGH when connected over TCP, LOW when disconnected. |

5.6. 4.6 Setting Print levels

There are a number of print functions that can be enabled to assist in debugging the operation and status of the module. The following command is used to control these printouts.

set sys printlvl <value> sets additional print functions. Bit-mapped value.

| Bit | Function |
|-----|--|
| 1 | Print startup messages showing progress of association, dhcp, etc. |

Once the configuration has been checked, this can then be turned off so that these messages do not interfere with the datastream.

6. Making an Outbound Connection

Setup steps:

set the remote IP address with **set ip host 10 10 10 20** for example. default remote port is 2000, set the port with **set ip remote 4000** if you need to change it.

Open the Connection: choose one of three ways.

A: go into command mode using **\$\$\$** and then send the **OPEN** command.
You can simply connect in-line with "**OPEN 10 10 10 20 2000** " for example.

B: set PIO5 to control the TCP connection (use **set sys io 1** to configure it)
Then setting PIO5 will connect, low will disconnect.

C: Auto connect after timer by using the command **set sys auto 5** for example.
This will automatically connect 5 seconds after powerup.

Monitoring Connect Status: if needed, connection status can be monitored by

A: reading PIO6. use the command **set sys io 2** to enable this mode.

B: Setup a string to be sent upon connect and disconnect:
example

set comm open %OPEN sends **%OPEN** out of the UART when the port is opened
set comm close %CLOSE sends **%CLOSE** out of the UART when the port is closed
set comm remote \$HELLO sends **\$HELLO** to the remote host upon port opened.

7. FTP Upgrade and Image Storage

Image Storage

WiFly contains a built file system for storing the firmware image(s). Files can be viewed with the **ls** command. Here is an example result:

```
File# Size
 2 12 wifly-1.05
14  1 config
```

113 Free, Boot=2, Backup=22.

Multiple files can be stored, and the boot image can be modified per below.

FTP Upload and Upgrade

WiFly contains a built in FTP client for getting files and updating the firmware. The client uses passive mode FTP, which allows operation thru firewalls and the Internet. There are 3 fixed settings that need to be used. The username is **roving**. The password is **Pass123**. The default directory is **/public**.

To setup FTP, the IP address of the remote server is stored using this command:

```
set ip ftp <addr> sets the ftp server address. .
```

To use FTP, enter the following command:

```
ftp get <name> Retrieves remote file.
```

Firmware Upgrade - automatic

To use FTP to upgrade the firmware, enter the following command:

```
ftp upload <filename> (filename is optional, default is "wifly.img" )
```

This will overwrite the current backup image, and updates the boot image. Here is an example of what you should see after a successful update:

```
File# Size Flgs
 2 12  3 wifly-1.23-WPA2 (old image)
14  1 10 config
15 12  3 wifly-1.26-OPEN (new image)
```

101 Free, Boot=15, Backup=2.

Firmware Upgrade - manual

If it desirable to keep old images, retrieve the file using **ftp get**, and then use the

Set boot <sector> command to set the current boot image number

www.rovingnetworks.com

support@rovingnetworks.com
Phone 408-395-6539

8. Security and Authentication Modes

The current release of Wifly firmware supports these security modes:

- WEP-128 (open mode only, NOT shared mode)
- WPA2-PSK (AES only)
- WPA1-PSK (TKIP only) this requires special firmware.

For WEP-128, shared mode is not supported as it is know to be quite easily compromised, and has been deprecated from the WiFi standards.

Roving Networks discourages the use of WPA1-PSK as it has been proven that mode can be compromised easily. Other modes, such as WPA-PSK mixed mode, and WPAenterprise are not yet supported, but may be offered in future releases. Contact Roving

Networks if you wish to discuss potential future support of other modes.

Listed below are the commands used to set authentication.

set wlan auth <value> sets the authentication level. 0= Open mode, 2=WPA2-PSK (AES only supported) , 3=WEP-128.

set wlan key <num> <value> sets the WEP key. key must be EXACTLY 13 bytes (26 ASCII chars). Data is expected in HEX format, "0x" should NOT be used here.

Example : "set w k 112233445566778899AABBCCDD"

Hex digits > 9 can be either upper or lower case.

set wlan phrase <string> sets the passphrase for WPA security modes. 1-64 chars. The passphrase can be alpha and numeric, and is used along with the ssid to generate a unique 32 byte Pre-shared key (PSK), which is then hashed into a 256 bit number.

Example : "set w p password" sets the phrase.

DIRECT PSK entry mode: If exactly 64 chars are entered, it is assumed that this entry is already an ASCII HEX representation of the 32 byte PSK and no processing is done.

Example : "set w p 0123456789.....AABBCCDD"

9. Factory Default Power up Settings

Note: PIO(9) IF pulled HIGH (3.3V) at power up time, and then toggled 3 times will change all settings below back to their factory values.

COMM PARAMETERS

| | |
|---------------|--------|
| Close string | <null> |
| Open string | <null> |
| Remote string | <null> |
| FlushSize | 16 |
| MatchByte | 0 |
| FlushTimer | 2 |
| IdleTimer | 0 |

IP PARAMETERS

| | |
|------------|---|
| protocol | TCP-Server |
| address | 0.0.0.0 |
| localport | 2000 |
| netmask | 255.255.255.0 |
| gateway | 0.0.0.0 |
| host | 0.0.0.0 |
| remoteport | 2000 |
| ftp | 208.109.78.34 (roving default update server) (port fixed at 21) |
| dhcp | 1 (enabled) |

SYSTEM PARAMETERS

| | |
|--------------|--|
| sleeptimer | 0 |
| waketimer | 10 (10 seconds after sleep we wake up) |
| trigger | 1 (SENS1 pin wakes up the device) |
| auto connect | 0 |
| iomask | 0x78 (3,4,5,6 outputs). |
| print level | 0 (prints disabled) |

TIME SERVER PARAMETERS

| | |
|---------|-------------|
| enable | 0= disabled |
| address | 0.0.0.0 |
| port | 0 |

UART PARAMETERS

| | |
|----------|------------|
| Baudrate | 9600 |
| parity | n (none) |
| flow | 0=disabled |

WLAN PARAMETERS

| | |
|----------------|--------------|
| authentication | 0=disabled |
| channel | 1 |
| ssid | roving1 |
| rate | 1 (1= 1Mbit) |

THIS IS THE END OF THE DOCUMENT

www.rovingnetworks.com

support@rovingnetworks.com
Phone 408-395-6539