



Chipsmall Limited consists of a professional team with an average of over 10 year of expertise in the distribution of electronic components. Based in Hongkong, we have already established firm and mutual-benefit business relationships with customers from,Europe,America and south Asia,supplying obsolete and hard-to-find components to meet their specific needs.

With the principle of “Quality Parts,Customers Priority,Honest Operation,and Considerate Service”,our business mainly focus on the distribution of electronic components. Line cards we deal with include Microchip,ALPS,ROHM,Xilinx,Pulse,ON,Everlight and Freescale. Main products comprise IC,Modules,Potentiometer,IC Socket,Relay,Connector.Our parts cover such applications as commercial,industrial, and automotives areas.

We are looking forward to setting up business relationship with you and hope to provide you with the best service and solution. Let us make a better world for our industry!



## Contact us

Tel: +86-755-8981 8866 Fax: +86-755-8427 6832

Email & Skype: info@chipsmall.com Web: www.chipsmall.com

Address: A1208, Overseas Decoration Building, #122 Zhenhua RD., Futian, Shenzhen, China



Instruction Manual

# Pirate - 4WD Mobile Platform

安装说明书

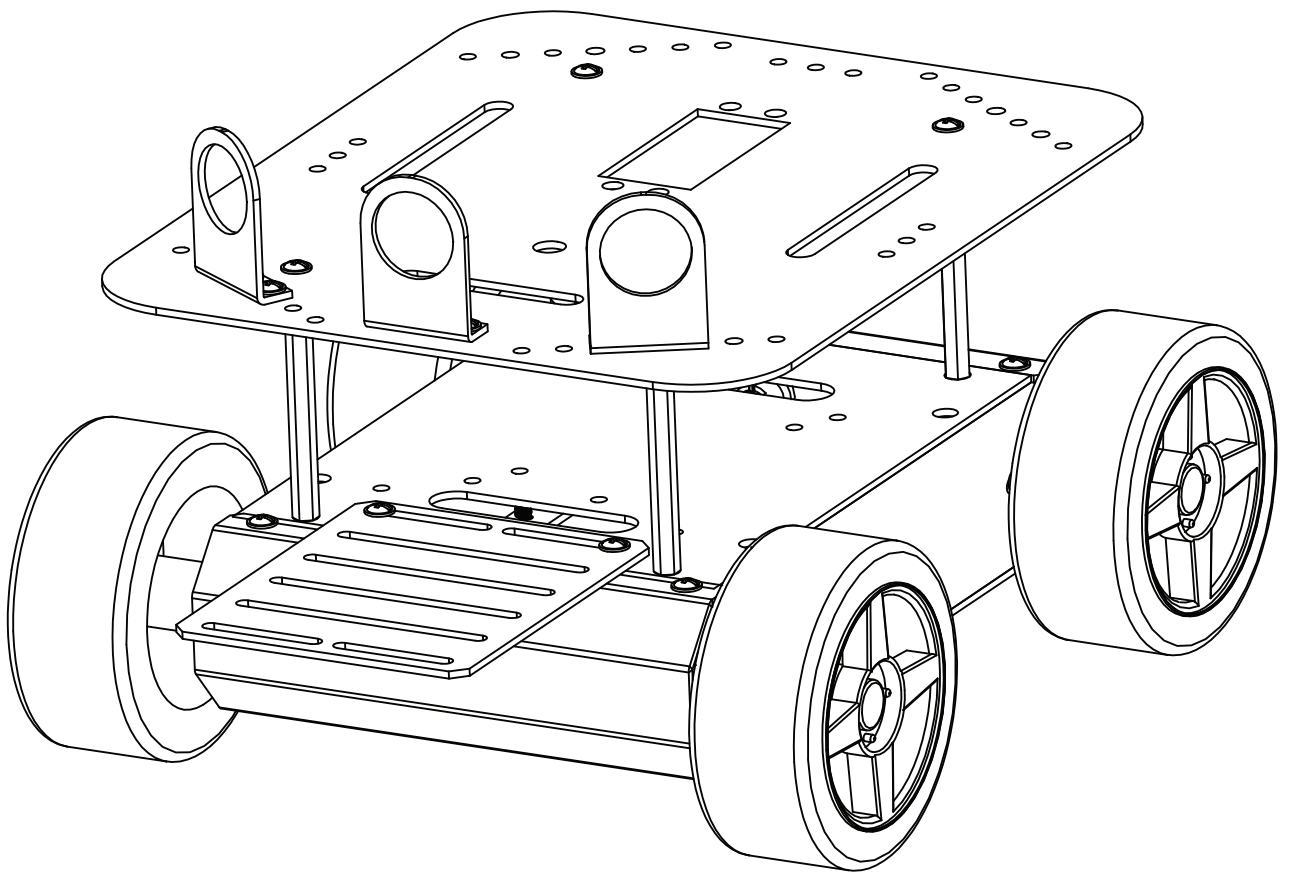

# 目录 Contents

产品特性 -----	1-2
Features	
产品安装说明 -----	3
Notice for Assembly	
电机安装 -----	4
Motors Assembly	
电池盒安装 -----	5
Battery Holder Assembly	
开关及插座安装 -----	6
Power Jack and Switch Assembly	
前后挡板安装 -----	7
Front and Rear Plate Assembly	
底板安装 -----	8
Base Plate Assembly	
传感器固定板安装 -----	9
Sensor Plate Assembly	
上盖板安装 -----	10
Top Plate Assembly	
红外传感器支架安装 -----	11
IR Sensor Bracket Assembly	
车身上板安装 -----	12
Upper Deck Assembly	
车轮安装 -----	13
Wheels Assembly	
零部件清单 -----	14-15
Parts List	



# 产品特性 Features

## 整机尺寸：

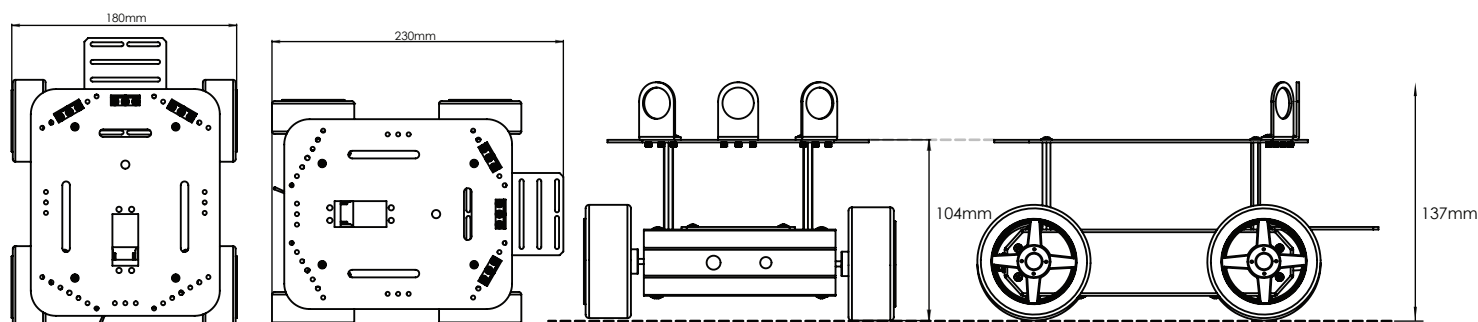

## 简介：

Pirate-4WD Mobile Platform 四轮驱动机器人是DFRobot研制的机器人实验平台，该平台不但可以用51控制、STC控制器、AVR控制器控制外，更适合使用世界上广泛推广的Arduino控制器，Arduino开放平台拥有全球众多使用者，有丰富的使用例子程序。机身采用高强度铝合金材料，高速电机加优质橡胶轮运动灵活快速，适合室内的平坦路面行进。使用Arduino控制器编程简单，控制起来非常有趣。适合机器人比赛，及其相关研究项目。本小车安装孔兼容多种传感器。

整机重量：710克

车轮直径：65mm

最大行驶速度:61cm/s

## 电机参数：

- 电机供电电压：3-6V
- 堵转电流(3V):260mA
- 减速比：1：120
- 堵转电流(6V):470mA
- 无负载转速(3V):100RPM
- 力矩(3V): 1.2Kgcm
- 无负载转速(6V):200RPM
- 力矩(6V): 1.92Kgcm
- 无负载运行电流(3V):60mA
- 重量:45g
- 无负载运行电流(6V):71mA

# 产品特性 Features

## Dimensions :

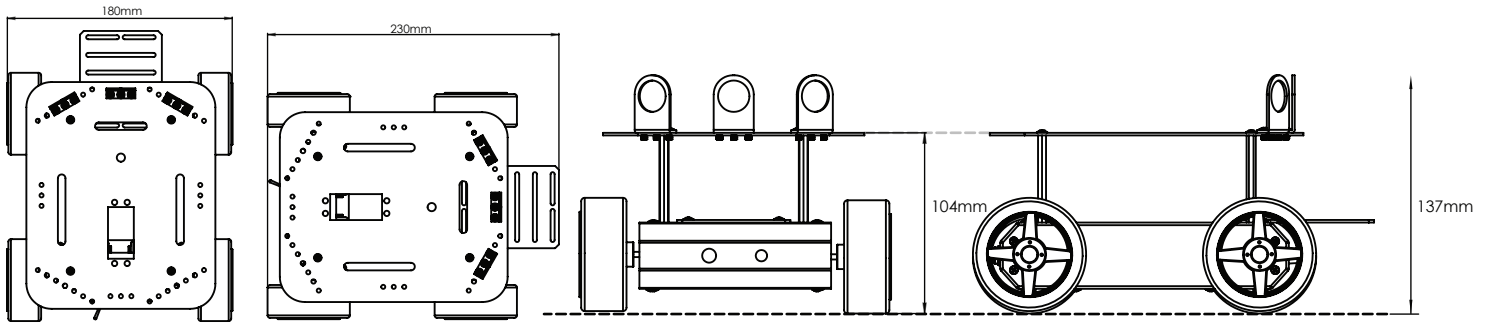

## Introduction :

The Pirate four-wheel-drive robot is a DFRobot original design and widely used as self-developed control panel for the Arduino platform. The platform can be controlled by a wide variety of microcontrollers including the widely popular Arduino. The Arduino platform has a large user base which provides a vast amount of resources and sample programs on the internet. The four different drives, powered by high-quality high-speed motors and flexible rubber wheels are mounted on a high-strength aluminum alloy body. This robotic platform is suitable for indoor use or flat road surfaces.

Complete Machine Weight: 710g

Wheel Diameter : 65mm

Highest Speed: 61cm/s

## Motor Feature :

- Gear Ratio : 1:120
- No-load speed (3V): 100RPM
- No-load speed (6V): 200RPM
- No-load current (3V): 60mA
- No-load current (6V): 71mA
- Stall current (3V): 260mA
- Stall current (6V): 470mA
- Torque (3V): 1.2Kgcm
- Torque (6V): 1.92Kgcm
- Weight : 45g

# 产品安装说明 Notice for Assembly

以下设备不包括在ROB0003的部件清单内，用户需自行配备：

1. 5节AA电池。
2. 控制器以及电机驱动器。

您还需要准备以下工具，并参考零部件清单进行ROB0003的安装：

1. 十字螺丝刀（适用于M2.5，M3，M4的螺丝）。
2. 尖嘴钳。

The following parts below are not included in the Parts List, they are self-provided:

1. AA battery (5 pieces).
2. Micro-controller and Motor driver.

When starting assembly, prepare tools below and pick out the parts referring to the Parts List:

1. Phillips screwdriver ( for screws M2.5 , M3 , M4 ) .
2. Needle noses pliers.

## 标志含义 Symbol Definition

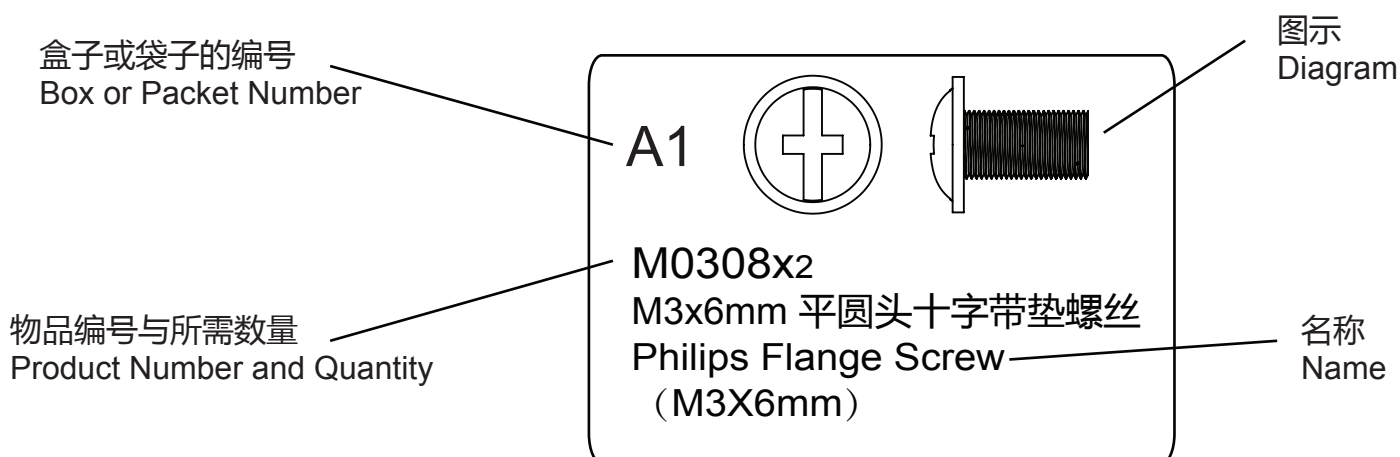

# 电机安装 Motors Assembly

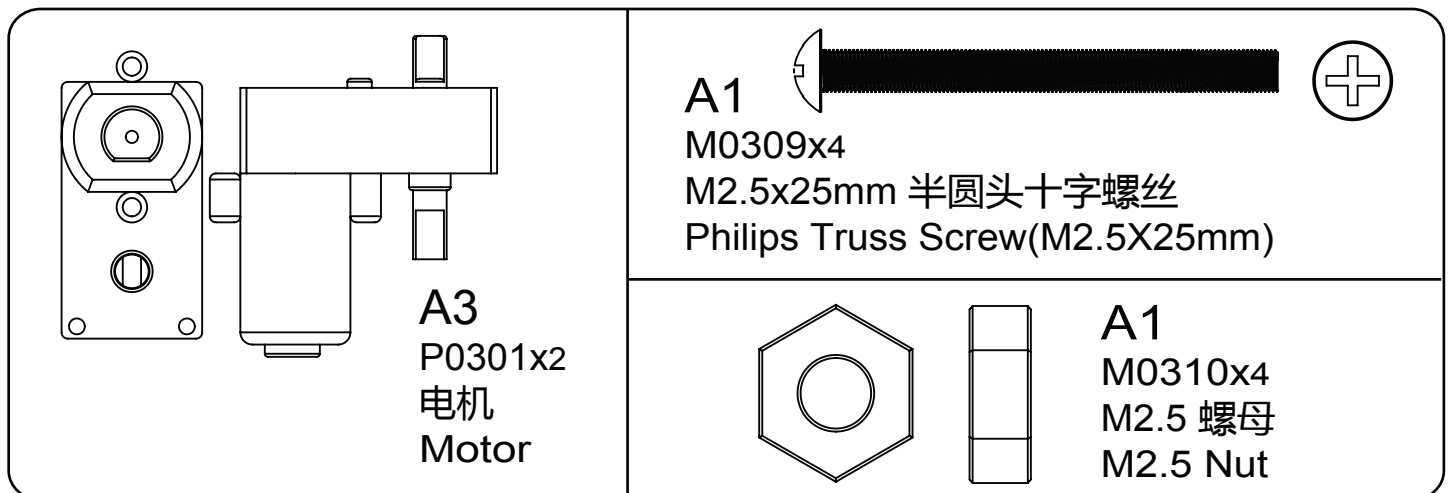
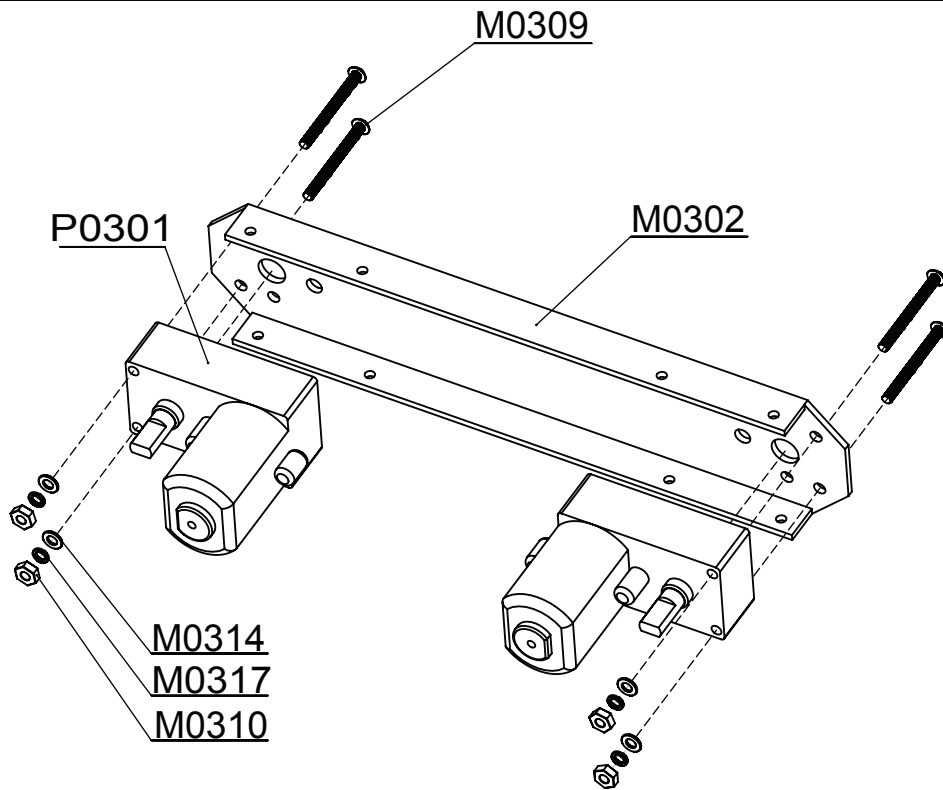
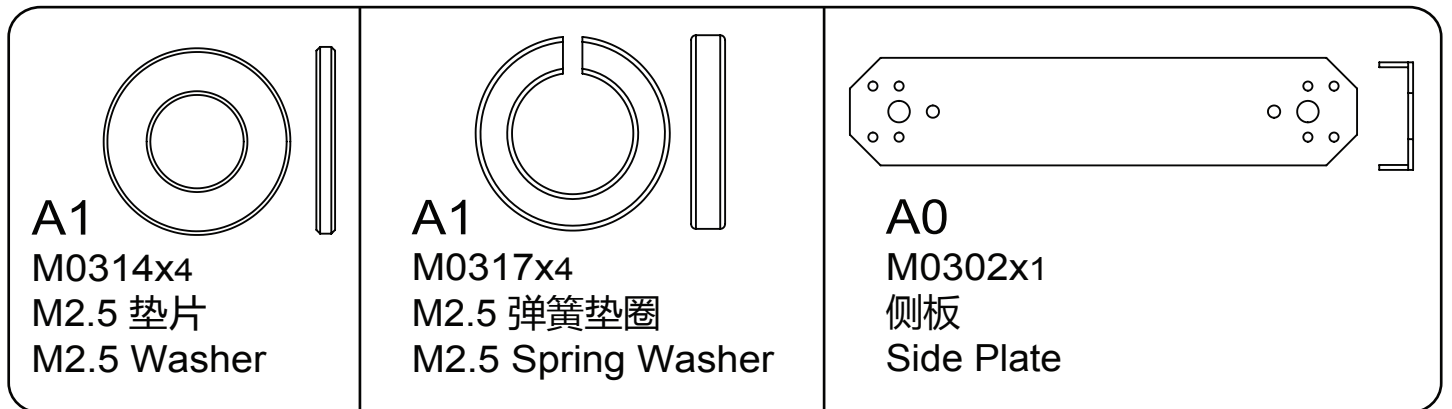

# 电池盒安装 Battery Holder Assembly

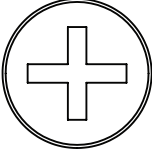
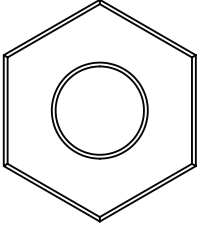
 <p><b>A1</b> M0307x2 M3x4mm 沉头十字螺丝 Philips Countersunk Screw(M3x4mm)</p>	 <p><b>A1</b> M0321x2 M3 螺母 M3 Nut</p>
--	--

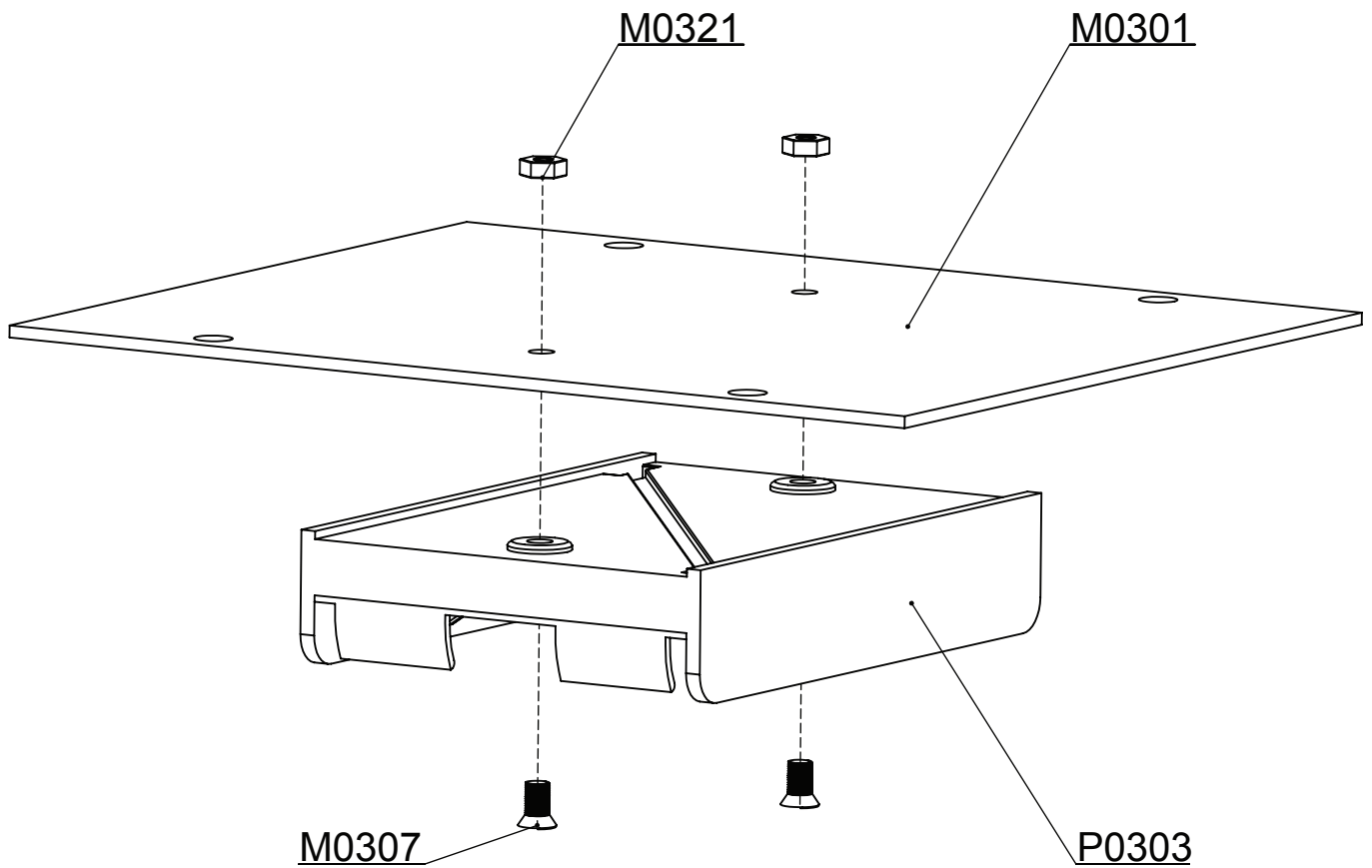

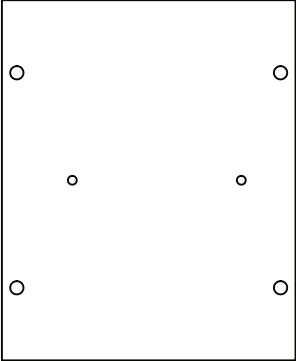
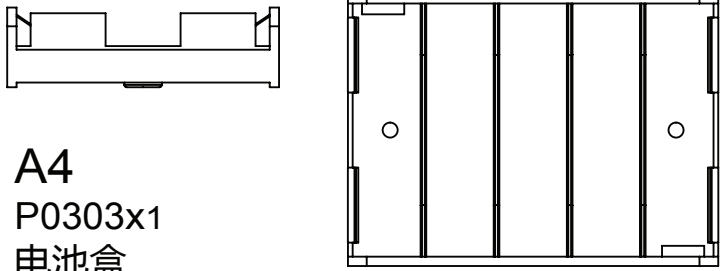
 <p><b>A0</b> M0301x1 底板 Base Plate</p>	 <p><b>A4</b> P0303x1 电池盒 Battery Holder</p>
--	--



# 开关及插座安装 Power Jack and Switch Assembly

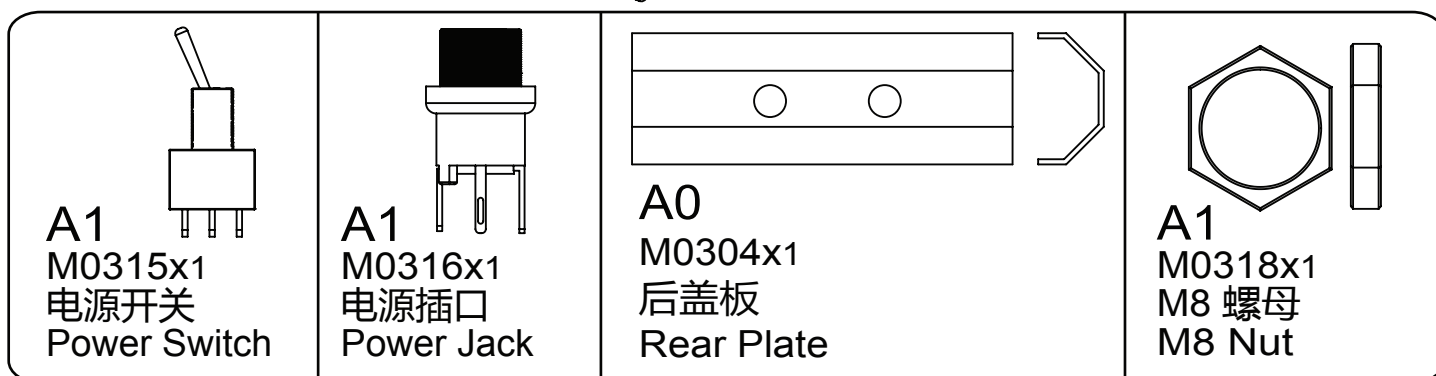
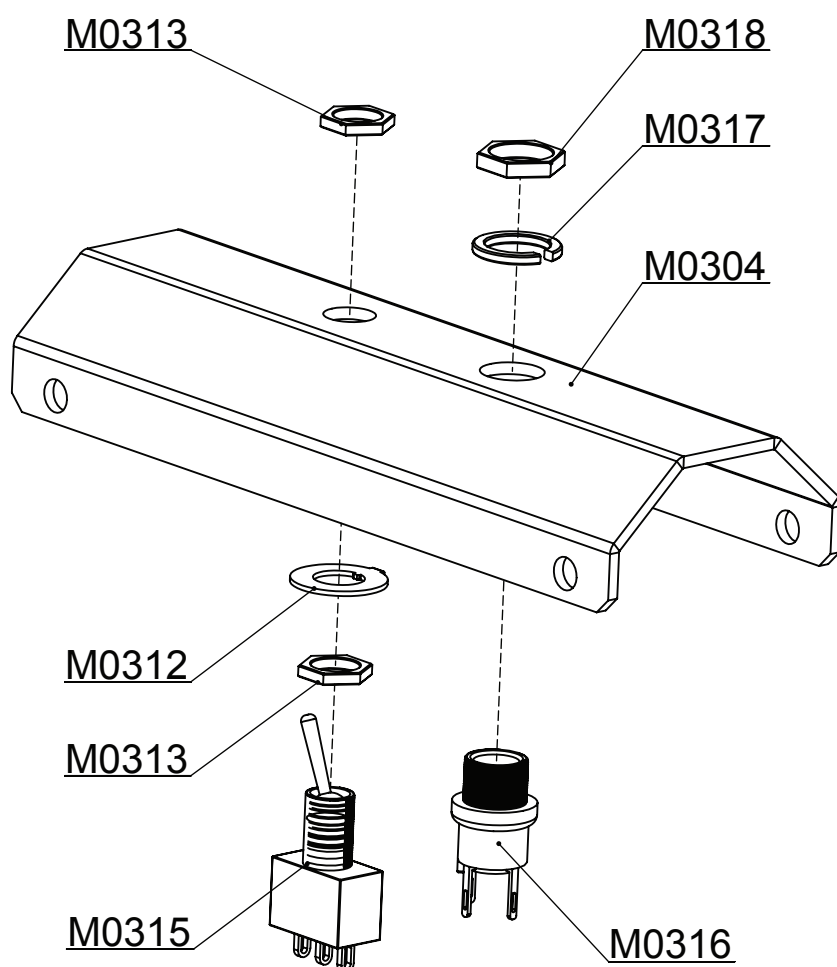
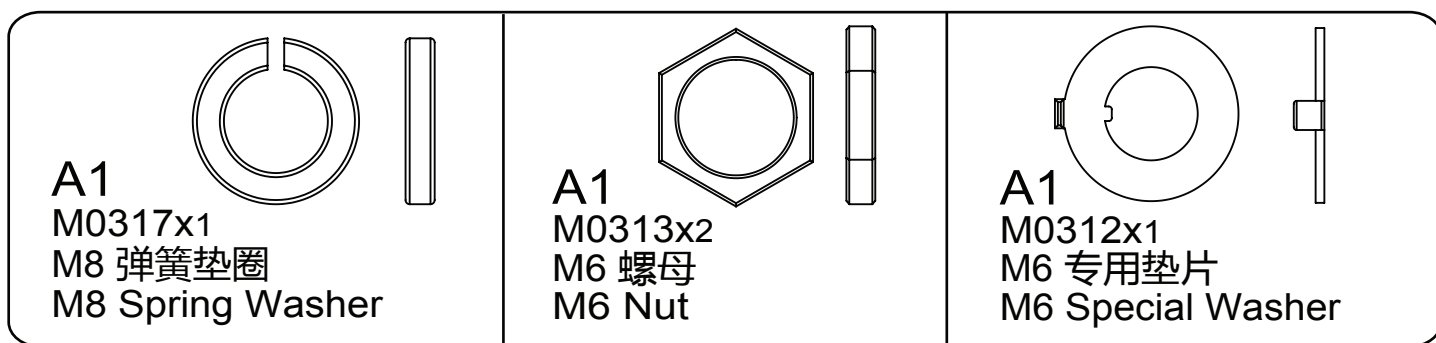

# 前后挡板安装 Front and Rear Plate Assembly

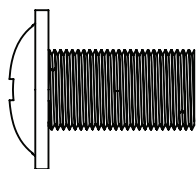
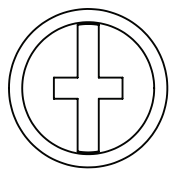
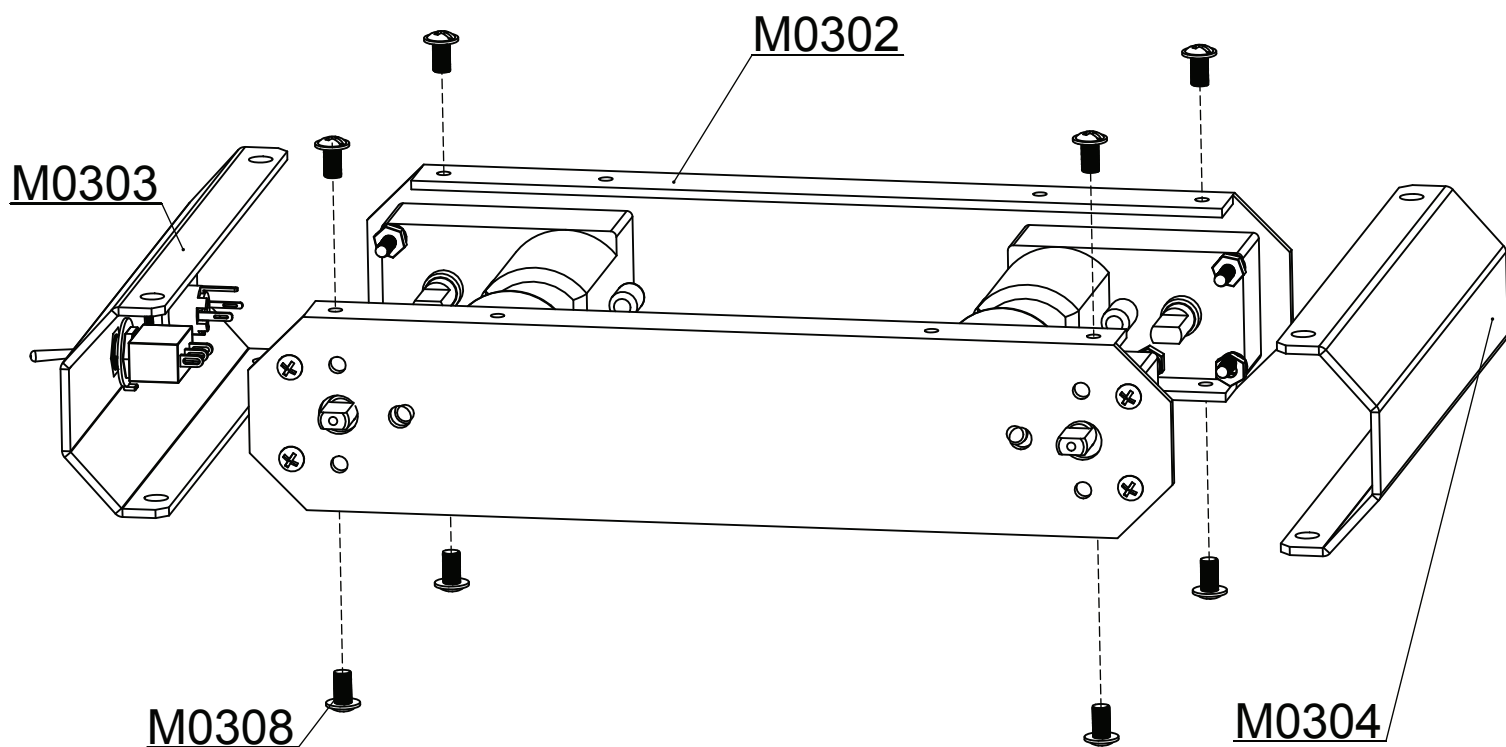

A1  
M0308x8  
M3x6mm 平圆头十字带垫螺丝  
Philips Flange Screw (M3x6)

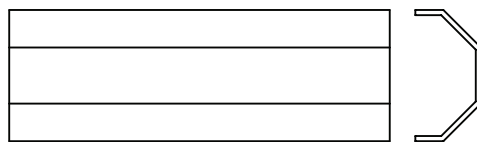

A0  
M0304x1  
前盖板  
Front Plate

# 底板安装 Base Plate Assembly

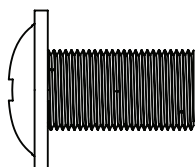
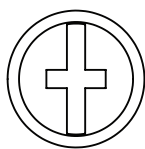
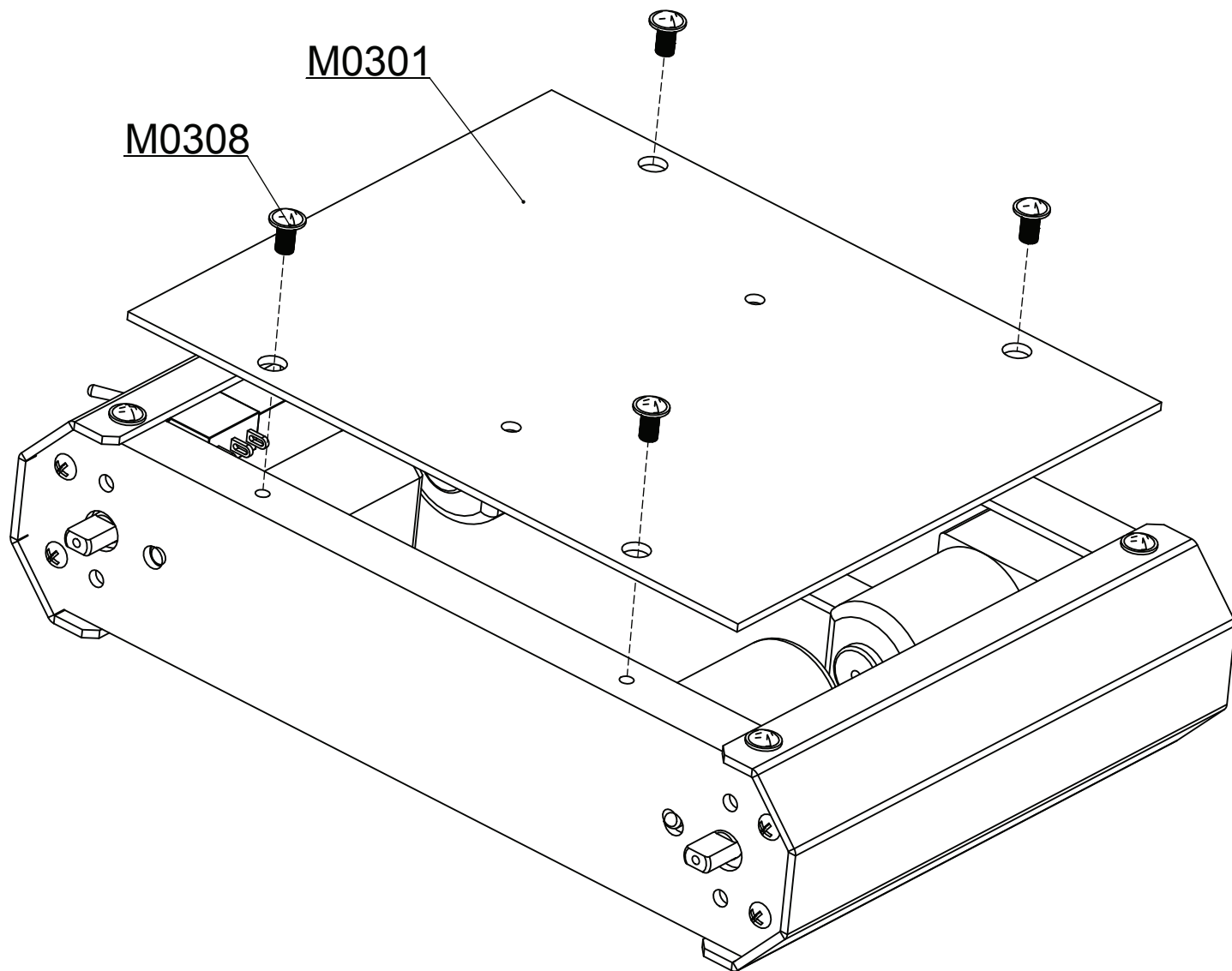

A1

M0308x4

M3x6mm 平圆头十字带垫螺丝

Philips Flange Screw (M3x6mm)

# 传感器固定板安装 Sensor Plate Assembly

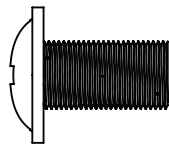

A1

M0308x2

M3x6mm 平圆头十字带垫螺丝

Philips Flange Screw (M3x6mm)

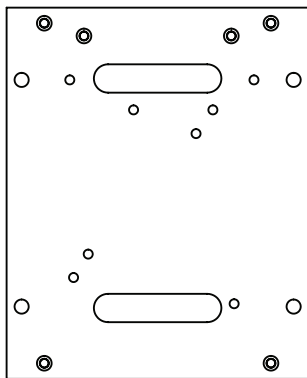
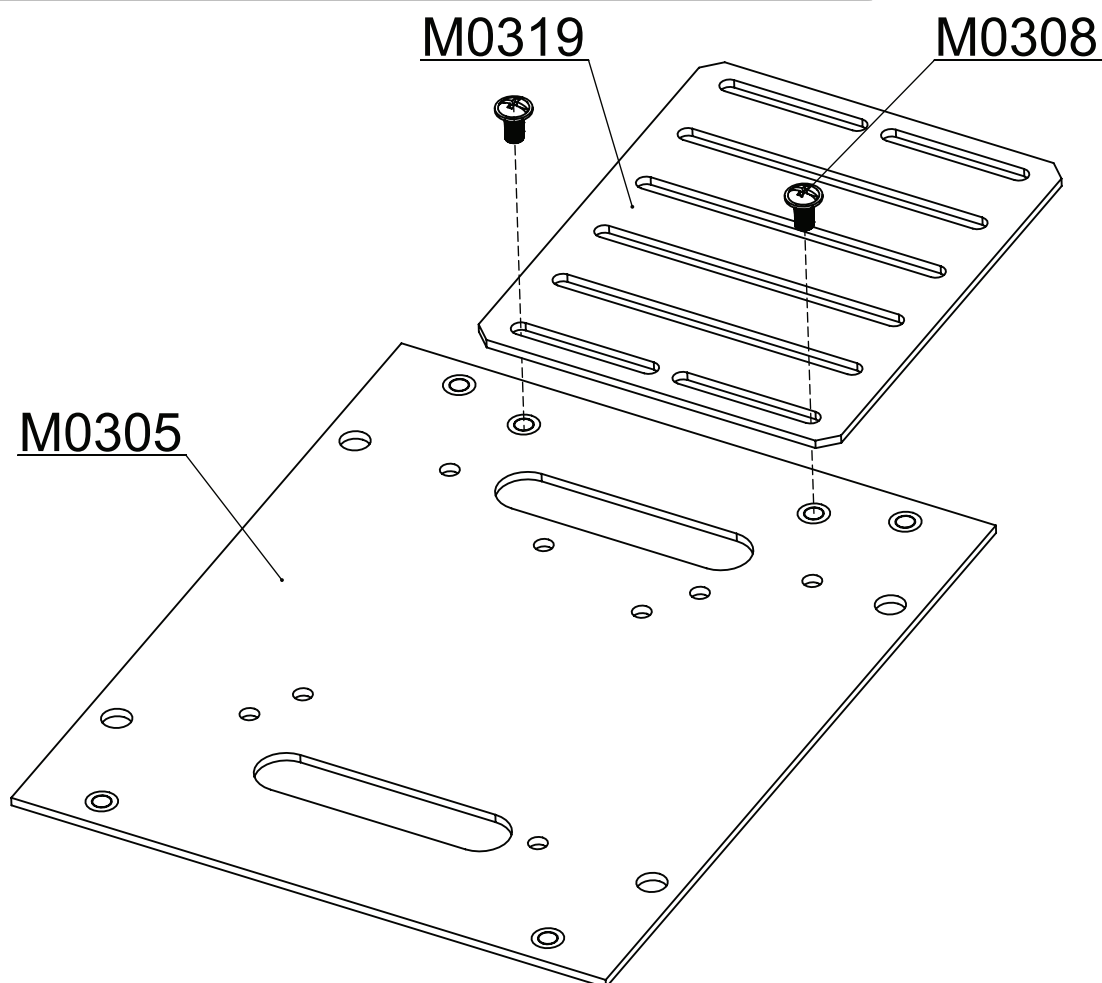

A0

M0305x1

上盖板

Top Plate

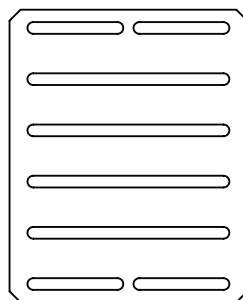

A2

M0319x1

传感器固定板

Sensor plate

# 上盖板安装 Top Plate Assembly

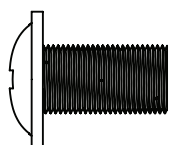
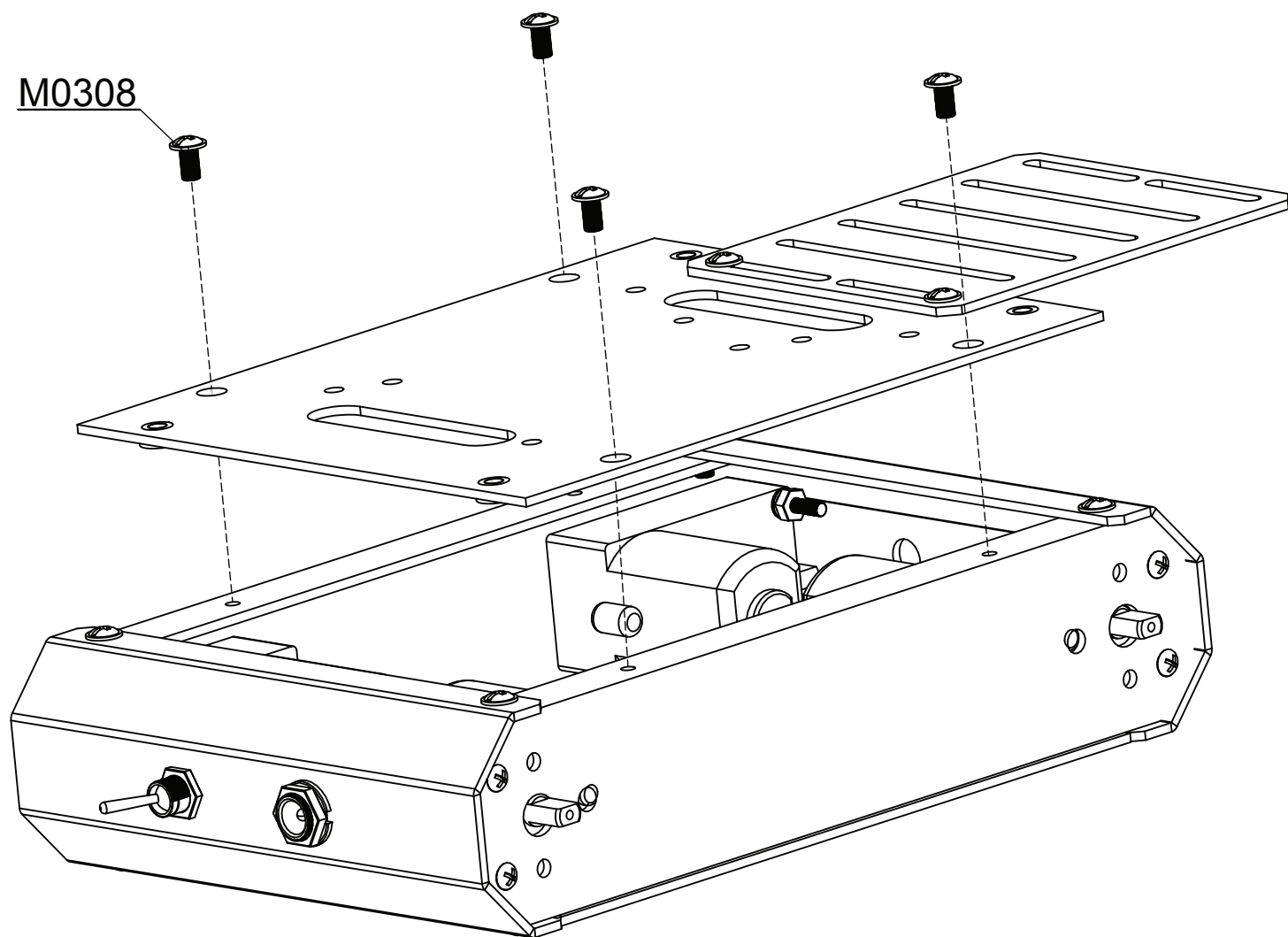

A1

M0308x4

M3x6mm 平圆头十字带垫螺丝

Philips Flange Screw (M3x6mm)



# 红外传感器支架安装 IR Sensor Bracket Assembly

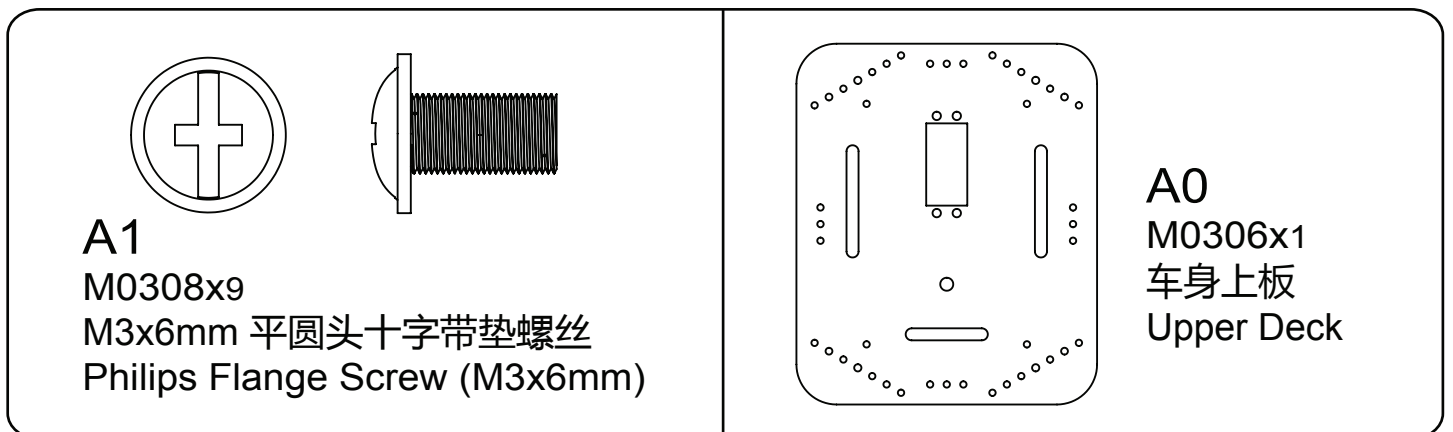
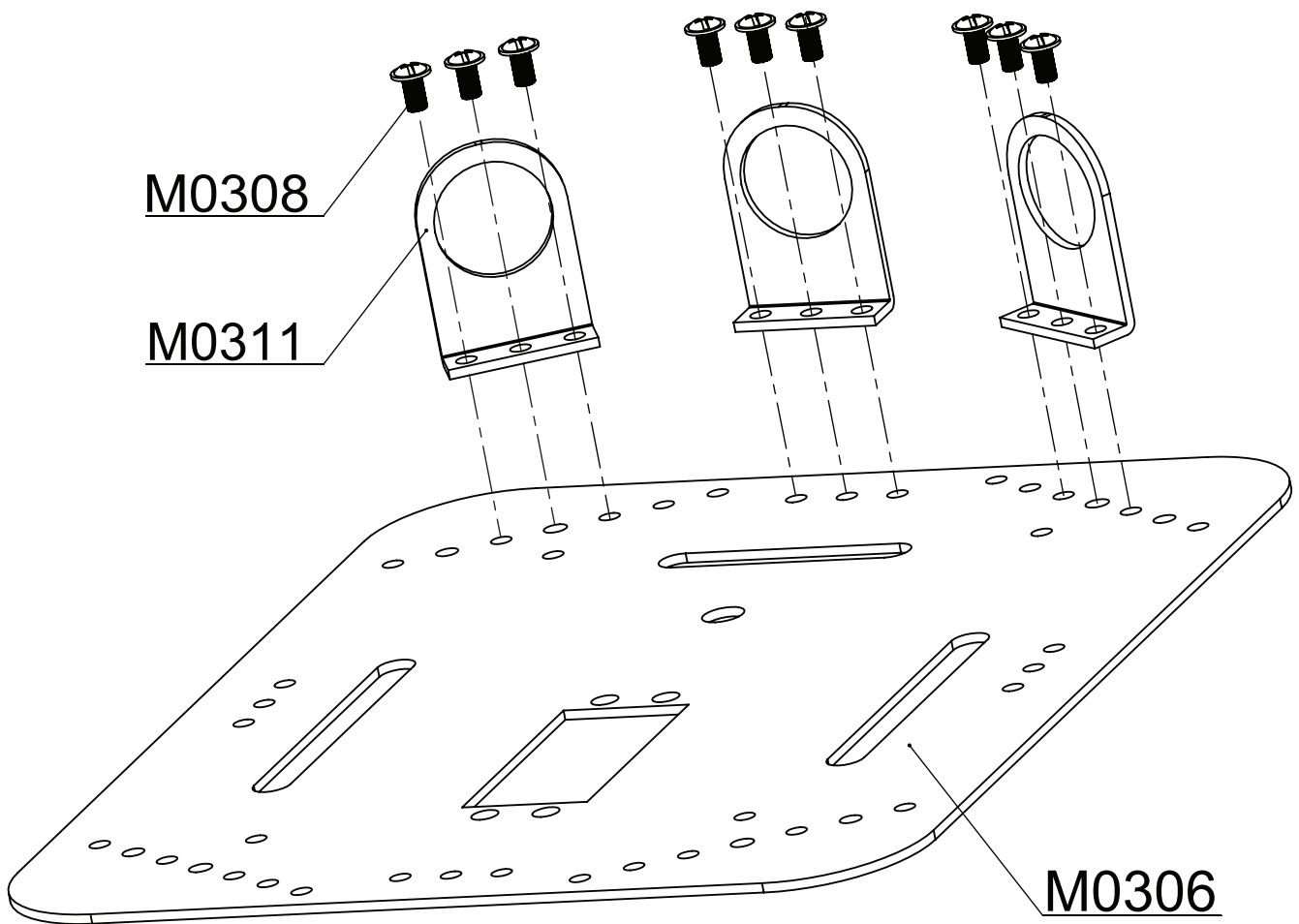

# 车身上板安装 Upper Deck Assembly

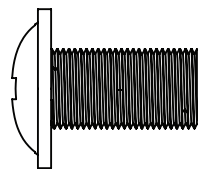
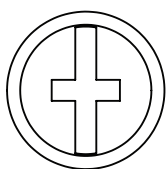
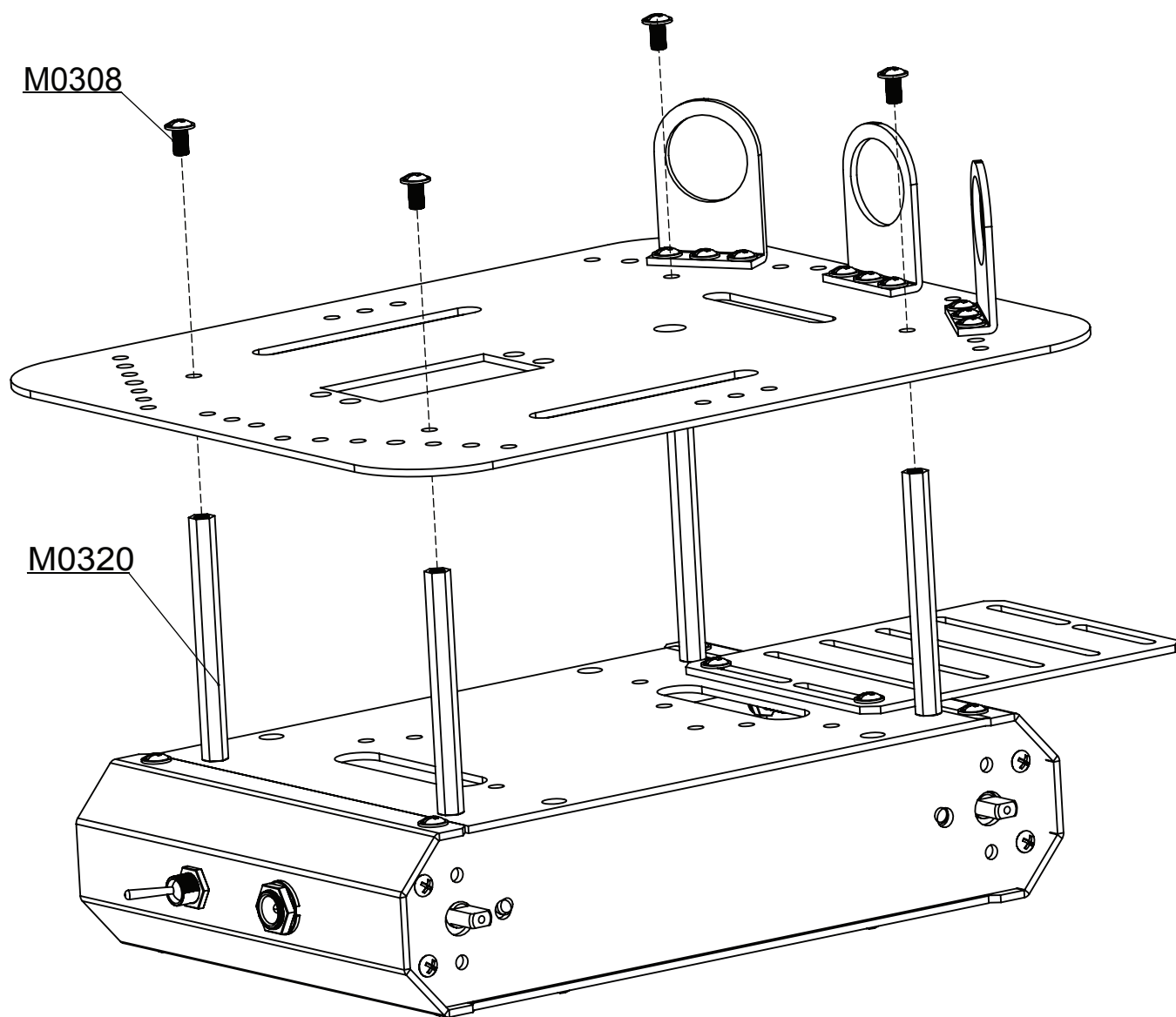

A1  
M0308x4  
M3x6mm 平圆头十字带垫螺丝  
Philips Flange Screw (M3x6mm)

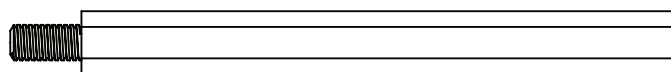

A1  
M0320x4  
M3x50mm 六角铜柱  
Copper Standoff (M3x50mm)

# 车轮安装 Wheels Assembly

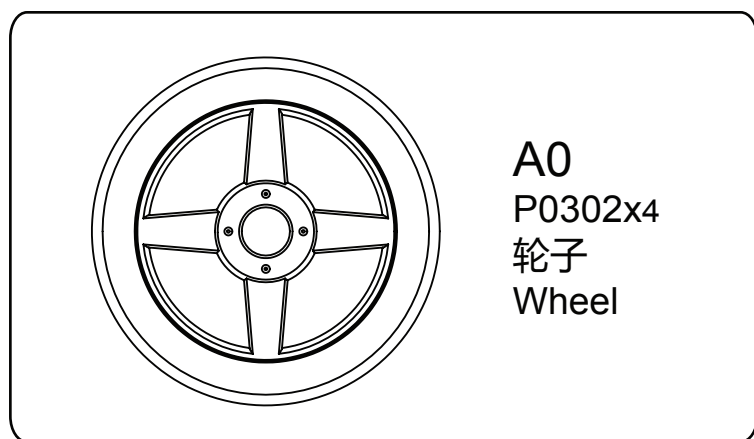
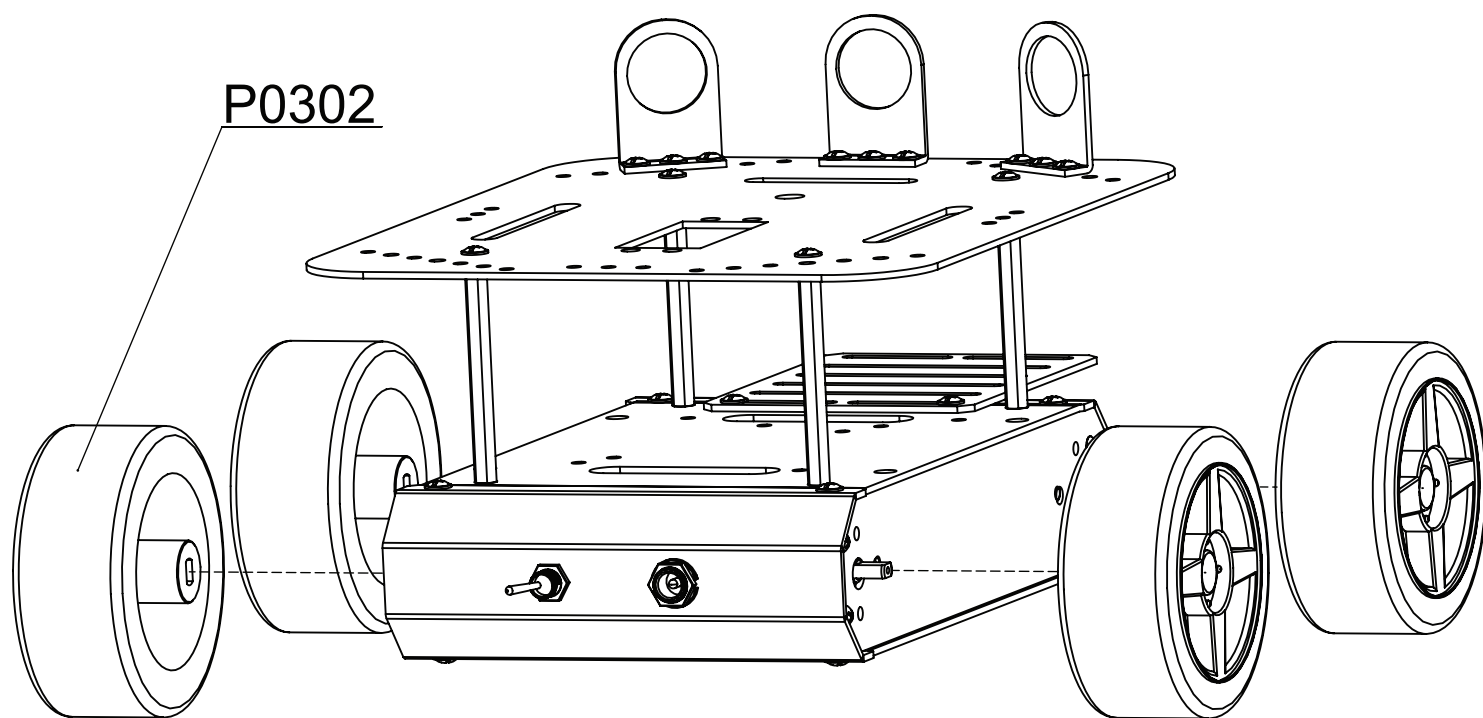

# 零部件清单(A) Parts List(A)

编号 Product NO.	盒编号 BOX	袋编号 Packet	名称 Name	数量 Amount	备注 Remark
M0301		A0	底板 Base Plate	1	
M0302		A0	侧板 Side Plate	2	
M0303		A0	后盖板 Rear Plate	1	
M0304		A0	前盖板 Front Plate	1	
M0305		A0	上盖板 Top Plate	1	
M0306		A0	车身上板 Upper Deck	1	
M0307		A1	M3X4mm 沉头十字螺丝 Philips Contersunk Screw(M3X4mm)	2	
M0308		A1	M3x6mm 平圆头十字带垫螺丝 Philips Flange Screw (M3x6mm)	31	
M0309		A1	M2.5X25mm 半圆头十字螺丝 Philips Truss Screw(M2.5X25mm)	8	
M0310		A1	M2.5 螺母 M2.5 Nut	8	
M0311		A1	红外传感器支架 IR Sensor Mounting Bracket	3	
M0312		A1	M6 专用垫片 M6 Special Washer	1	

# 零部件清单(B) Parts List(B)

编号 Product NO.	盒编号 BOX	袋编号 Packet	名称 Name	数量 Amount	备注 Remark
M0313		A1	M6 螺母 M6 Nut	2	
M0314		A1	M2.5 垫圈 M2.5 Washer	8	
M0315		A1	电源开关 Power Switch	1	
M0316		A1	电源插口 Power Jack	1	
M0317		A1	M2.5 弹簧垫圈 M2.5 Spring Washer	9	
M0318		A1	M8 螺母 M8 Nut	1	
M0319		A2	传感器固定板 Sensor Plate	1	
M0320		A1	M3x50mm 六角铜柱 Copper Standoff (M3x50mm)	4	
M0321		A1	M3 螺母 M3 Nut	2	
P0301		A3	电机 Motor	4	
P0302		A0	轮子 Wheel	4	
P0303		A4	电池盒 Battery Holder	1	



设计与监制  
Design&Executive

北京龙凡汇众机器人科技有限公司  
Beijing LongFanHuiZhong Robotics  
Technology CO.,LTD

服务支持  
Service

Service@DFRobot.com

网站  
Website

www.DFRobot.com.cn  
www.DFRobot.com

本说明书最终解释权归DFRobot所有

DFRobot has the final authority of interpretation on this manual.

**DFRobot**