



Chipsmall Limited consists of a professional team with an average of over 10 year of expertise in the distribution of electronic components. Based in Hongkong, we have already established firm and mutual-benefit business relationships with customers from,Europe,America and south Asia,supplying obsolete and hard-to-find components to meet their specific needs.

With the principle of "Quality Parts,Customers Priority,Honest Operation,and Considerate Service",our business mainly focus on the distribution of electronic components. Line cards we deal with include Microchip,ALPS,ROHM,Xilinx,Pulse,ON,Everlight and Freescale. Main products comprise IC,Modules,Potentiometer,IC Socket,Relay,Connector.Our parts cover such applications as commercial,industrial, and automotives areas.

We are looking forward to setting up business relationship with you and hope to provide you with the best service and solution. Let us make a better world for our industry!



Contact us

Tel: +86-755-8981 8866 Fax: +86-755-8427 6832

Email & Skype: info@chipsmall.com Web: www.chipsmall.com

Address: A1208, Overseas Decoration Building, #122 Zhenhua RD., Futian, Shenzhen, China





RP-M100A Datasheet

**(No. BRP0005)
V.2.0**

REVISION HISTORY

Version	Date	Description
VER.1.0	2011.1.24	▪ First Version Release
VER.2.0	2012.1.20	▪ Section 2.2.1 - Figure 1 is changed. ▪ Section 2.3/2.4/2.5/2.6 are modified. ▪ Schematic in Sec 3 is changed. ▪ Section 4.1 is modified.

CONTENTS

1. SPECIFICATIONS	4
1.1. DESCRIPTION	4
1.2. DRAWING	4
1.2.1. <i>Outline</i>	4
1.2.2. <i>PCB drawing (top view)</i>	5
2. PIN DESCRIPTION	6
2.1. SOLDER MASK DESIGN(EXAMPLE)	6
2.2. SILK PRINT DESIGN(EXAMPLE)	6
2.3. ELECTRICAL INTERFACE	7
2.4. ABSOLUTE MAXIMUM RATINGS	8
2.5. DC CHARACTERISTICS	8
2.6. ELECTRICAL SPECIFICATIONS	8
3. APPLICATION DESIGN GUIDE	11
3.1. SCHEMATIC FOR APPLICATION	11
3.2. ANTENNA DESIGN	12
3.3. CIRCUIT FOR SENSOR DETECTION	13
3.4. POWER SUPPLY CIRCUIT	14
3.5. GROUND	15
3.5.1. <i>One Ground</i>	15
3.5.2. <i>Two Ground</i>	15
3.6. RESET CIRCUIT	16
3.7. ISP	16
3.8. UART INTERFACE	17
3.9. INTERRUPT	17
3.10. REMOCON CIRCUIT EXAMPLE1	18
3.11. APPLICATION CIRCUIT EXAMPLE2	19
4. RELIABILITY & ANTENNA SPECIFICATION	20
4.1. RELIABILITY	20
4.2. SPECIFICATION OF ANTENNA	20
5. REFLOW PROFILE	21
6. PACKAGE	22
6.1. DIMENSIONS OF TAPE	22
6.2. DIMENSIONS OF REEL	22
6.3. TAPING STYLE	22

1. SPECIFICATIONS

This specification is applied to IEEE802.15.4 ZigBee Transceiver Module.
This module is embedded with Chip Antenna, 16MHz X-TAL and Single chip SOC.

1.1. Description

Item	Description
Application	Transceiver Module
Frequency Range	2.4 ~ 2.4835 GHz
Technical Standard	IEEE802.15.4
Type	SMD Type
Size	17.9 x 14.9 x 2.6 mm

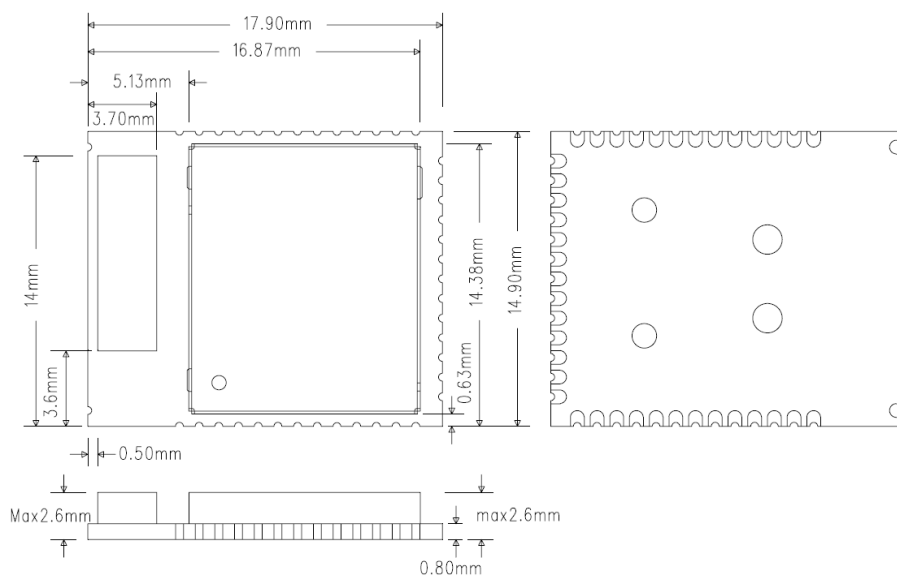

1.2. Drawing

1.2.1. Outline

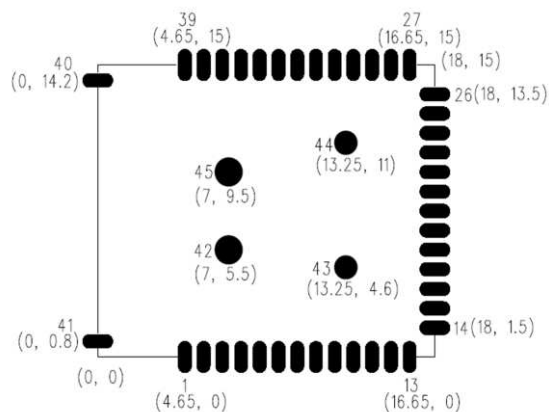

1.2.2. PCB drawing (top view)



-  Pads of pin 1~41; (W*L: 0.7*1.6mm)
-  Pads of pin 42, 45; (R=0.75, Circle)
-  Pads of pin 43, 44; (R=0.625, Circle)

NOTE1: Soldermask opening of 42~45 pins should be enough about 25~50% against these pads size .

NOTE2: Silk paste inserting for Short protection, when soldering.

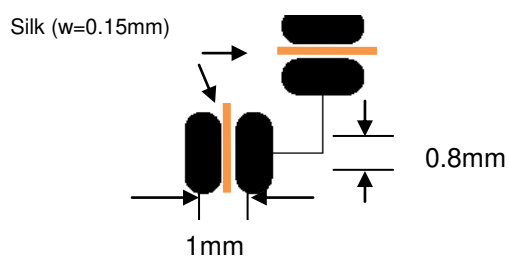

2. PIN DESCRIPTION

2.1. Solder Mask Design(Example)

Soldering pad	Pad type	Pad size	Mask open size	Result
		0.7mm(W)*1.7mm(L)	0.665mm(W) * 1.870mm(L)	W: 95% OPEN L: 110% OPEN
		Φ1.5mm	Φ0.7mm	46.7% OPEN
		Φ1.25mm	Φ0.5mm	40% OPEN

Note1) Solder mask thickness : 0.12t(0.12mm)

2.2. Silk Print Design(Example)

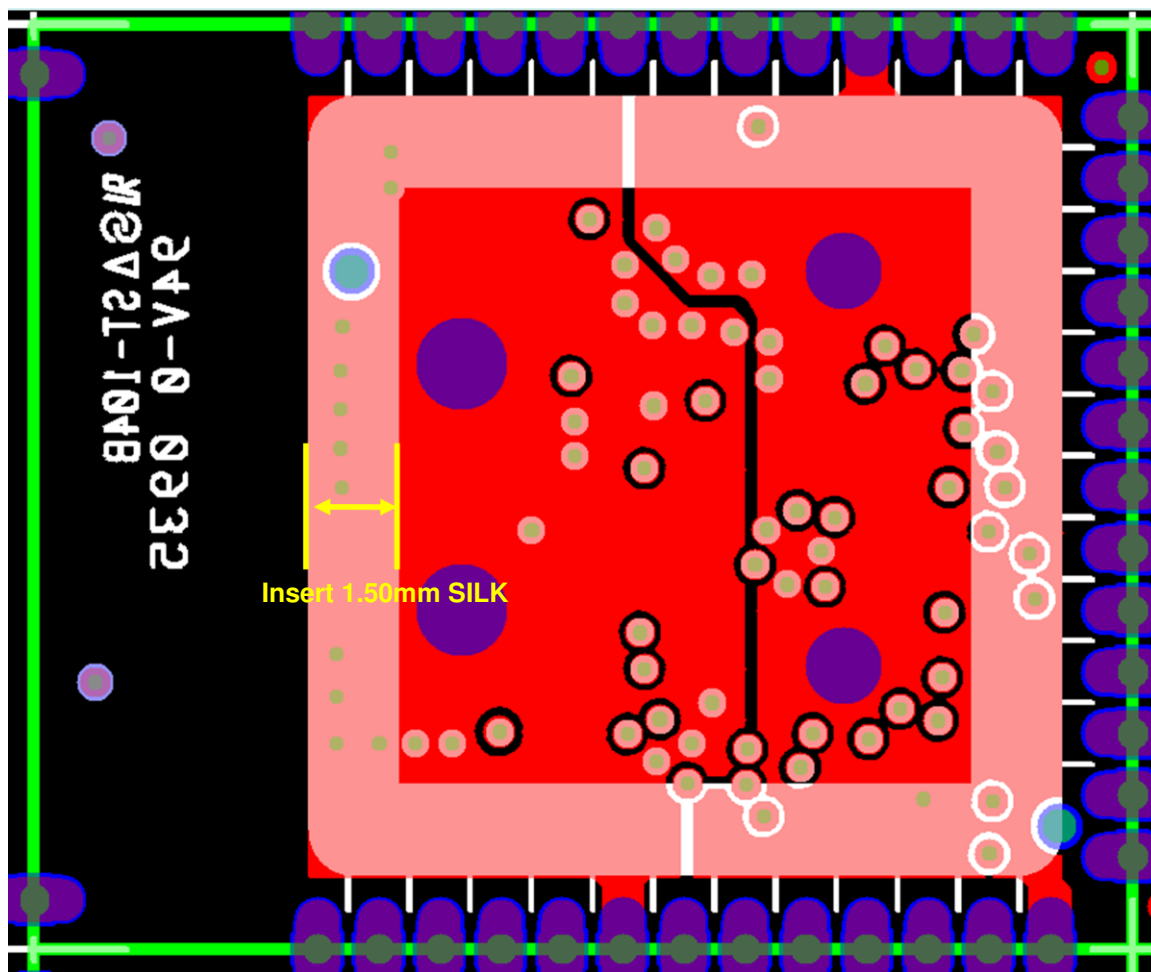

NOTE: Silk paste inserting for Short protection, when soldering.

2.3. Electrical Interface

Terminal	NAME	Inter face	I/O	Description
1	ACH0	Analog	I/O	Sensor ADC input
2	ACH1	Analog	I/O	Sensor ADC input
3	ACH2	Analog	I/O	Sensor ADC input
4	ACH3	Analog	I/O	Sensor ADC input
5	AVDD_1.5V	Power	I/O	1.5V Power Supply input/output
6	AGND	Ground	-	RF Ground
7	MS0	Digital	I	Mode select
8	MS1	Digital	I	Mode select
9	MS2	Digital	I	Mode select
10	MSV	Digital	I	Mode select of voltage(0=1.5V)
11	RESETB	Digital	I	Reset (Active Low)
12	3V IN	Power	I	3V Power supply
13	DGND	Ground	-	Ground for digital core and I/O
14	P1[7]	Digital	O	Port P1.7GPO/P0AND/TRSW
15	P1[6]	Digital	B	Port P1.6/TRSWB
16	P1[5]	Digital	B	Port P1.5
17	P1[4]	Digital	B	Port P1.4 /QUADZB/Sleep Timer OSC Buffer Input.
18	P1[3]	Digital	B	Port P1.3/QUADZA/Sleep Timer OSC Buffer Output/RTCLKOUT
19	P1[2]	Digital	B	Port P1.2
20	P1[1]	Digital	B	Port P1.1/TXD1
21	P1[0]	Digital	B	Port P1.0/RXD1
22	P3[7]	Digital	B	Port P3.7/12mA Drive capability /PWM3/CTS1/SPICSN(slave only)
23	P3[6]	Digital	B	Port P3.6/12 mA Drive capability /PWM2/RTS1/SPICLK
24	P3[5]	Digital	B	Port P3.5/T1/CTS0/QUADYB/SPIDO
25	P3[4]	Digital	B	Port P3.4/T0/RTS0/QUADYA/SPIDI
26	P3[3]	Digital	B	Port P3.3/INT1(active low)
27	P3[2]	Digital	B	Port P3.2/INT0(active low)
28	P3[1]	Digital	B	Port P3.1/TXD0/QUADXB
29	P3[0]	Digital	B	Port P3.0/RXD0/QUADXA
30	DGND	Ground	-	Ground for digital core and I/O
31	DVDD_1.5V	Power	I/O	1.5V Power Supply input/output
32	P0[7]	Digital	B	Port P0.7/I2STX_MCLK
33	P0[6]	Digital	B	Port P0.6/I2STX_BCLK
34	P0[5]	Digital	B	Port P0.5/I2STX_LRCK
35	P0[4]	Digital	B	Port P0.4/I2STX_DO
36	P0[3]	Digital	B	Port P0.3/I2SRX_MCLK
37	P0[2]	Digital	B	Port P0.2/I2SRX_BCLK
38	P0[1]	Digital	B	Port P0.1/I2SRX_LRCK
39	P0[0]	Digital	B	Port P0.0/I2SRX_DI
40	NC	NC	-	No Connection
41	NC	NC	-	No Connection
42	AGND	Ground	-	RF Ground
43	DGND	Ground	-	Ground for digital core and I/O
44	DGND	Ground	-	Ground for digital core and I/O
45	AGND	Ground	-	RF Ground

2.4. Absolute Maximum Ratings

Symbol	Parameter	Rating	Unit
VDD	Chip core supply voltage	-0.3 to 1.65	V
VDDIO	I/O supply voltage(3V_IN)	-0.3 to 3.3	V
RFIN	Input RF level	10	dBm
TSTG	Storage Temperature	-40 to 85	°C
ESD	HBM(JESD22-A114-F)	2000	V
	MM(JESD22-A115-A)	150	V
	CDM(JESD22-C101-E)	500	V

2.5. DC Characteristics

Symbol	Parameter	Min	Typ.	Max	Unit
VDD	Chip core supply voltage (AVDD_1.5V,DVDD_1.5V)	1.35	1.5	1.65	V
VDDIO	I/O supply voltage(3V_IN)	1.35(*)	3.0	3.3	V
VIH	High level input voltage	0.7X VDDIO		VDDIO	V
VIL	Low level input voltage	0		0.3X VDDIO	V
VOH	High level output voltage	VDDIO -0.5		VDDIO	V
VOL	Low level output voltage	0		0.4	V
TA	Air temperature	-40		85	°C

(*) : MSV="L", min 1.9V(regulator drop voltage), 3VIN=2.7~3.3V is recommended.

2.6. Electrical Specifications

(Condition: EVM Board RF Conduction, at 25°C, 3V_IN=3.0V, VDD(AVDD,DVDD=1.5V,X-tal 16MHz.)

Parameter	Min	Typ.	Max	Unit
Current consumption				
Active MCU without RX/TX operation (AES, Peripheral, SADC Disabled)		4.6		mA
Active MCU with TX Mode (AES, Peripheral, SADC Disabled) @ +8dBm output power		45.0		mA
Active MCU with RX Mode (AES, Peripheral, SADC Disabled) @+0dBm output power		32.5		mA
Active MCU with RX Mode (AES, Peripheral, SADC Disabled)		35		mA
PM1(BOD Off)		25	90	uA
PM2		1.7		uA
PM3		0.3		uA
AES		3.1		mA
Peripheral		2.6		mA
Sensor ADC		1		mA
RF Characteristics(Fc=2450MHz)				
RF Frequency Range	2400		2483.5	MHz

Spurious radiation @30MHz ~ 1000MHz @1GHz ~ 12.75GHz		-65 -70		dBm
Received RF Bandwidth		2		MHz
Channel Bandwidth		5		MHz
Receiver Sensitivity (PER≤1%,Packet length of 22-byte) Normal mode (250 kbps) Turbo mode (500 kbps) Premium mode (1000 kbps)		-98 -95 -91		dBm
Adjacent Channel Rejection +5MHz -5MHz		50 49		dB
Alternate Channel Rejection +10MHz -10MHz		55 54		dB
Co-Channel Rejection		-8		dB
Blocking / Desensitization +5MHz / -5MHz +10MHz / -10MHz +20MHz / -20MHz +30MHz / -30MHz +50MHz / -50MHz		-53 / -52 -48 / -46 -44 / -40 -43 / -38 -41 / -37		dBm
TX output power		5.5	8	dBm
Transmit chip rate		2000		kChips /s
Spurious Emission(30Hz~1GHz)		-50		dBm
Spurious Emission(1GHz~2.5GHz)		-40		dBm
Spurious Emission(2.5GHz~12.7GHz)		-50		dBm
2 nd Harmonics		-50		dBm
3 rd Harmonics		-65		dBm
Frequency Error Tolerance	-100		+100	KHz
Error Vector Magnitude(EVM)		10	35	%
Saturation(Maximum Input Level)		5		dBm
RSSI Dynamic Range		90		dB
RSSI Accuracy		±1.2	+6/-3	dB
RSSI Linearity		±0.2	±6	dB
RSSI Average Time		128		usec
Frequency Synthesizer				
Phase Noise (Unmodulated carrier) @±100KHz offset @±1MHz offset @±2MHz offset @±3MHz offset		-75 -106 -112 -119		dBc/Hz

@±5MHz offset		-129		
PLL Lock Time		110		us
PLL Jitter		16		Psec
16MHz Crystal Oscillator				
Crystal Frequency		16		MHz
Crystal Frequency Accuracy Requirement	-20		+20	ppm
ESR			80	Ω
C0			3	pF
CL		9		pF
On-chip RC Regulator				
Frequency		32.78		KHz
Sensor ADC				
Number of Bits		12		bits
Conversion Time		256		usec
Differential Nonlinearity(DNL)		±16		LSB
Integral Nonlinearity(INL)		±16		LSB
SINAD(Sine Input)		51.0		dB
On-Chip Voltage Regulator				
Supply range for Regulator	1.9	3.0	3.6	V
Regulated Output		1.5		V
Maximum Current			140	mA
No Load Current		15		uA
Start-up Time		260		usec

3. APPLICATION DESIGN GUIDE

3.1. Schematic for Application

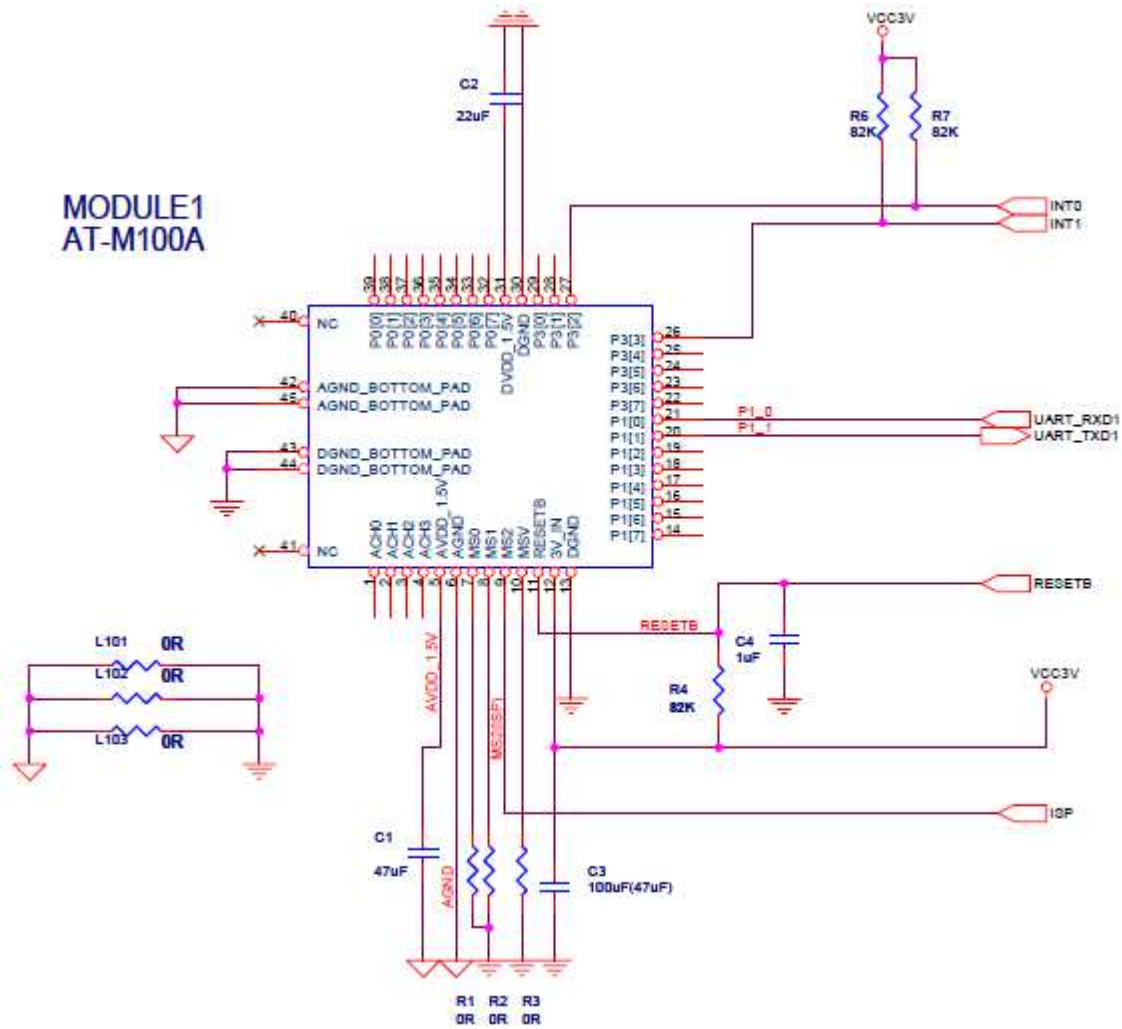

3.2. Antenna Design

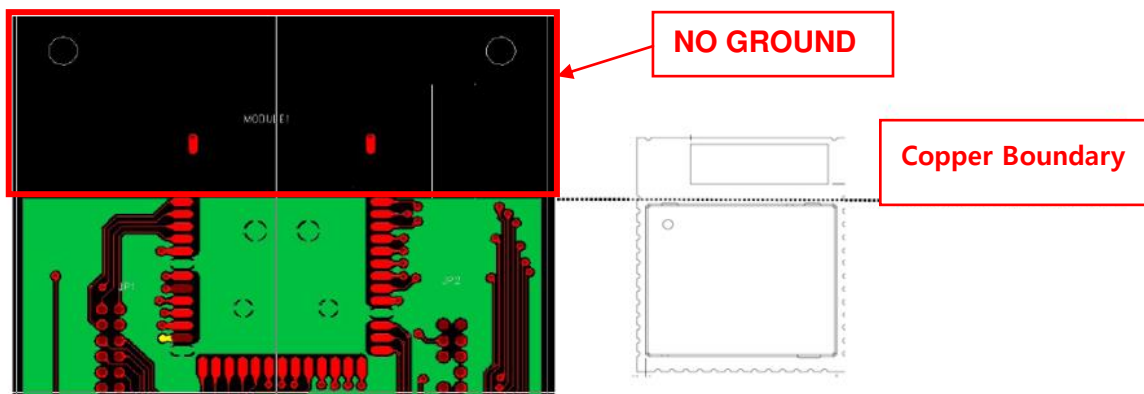

Influence of GND on Antenna

- a) The GND interrupts the emission of antenna but is essential.
- b) RF vertical GND is important in antenna design.
- c) Normally, the emission rate is improved as more GND is secured and edged GND of antenna is cut.

3.3. Circuit for Sensor Detection

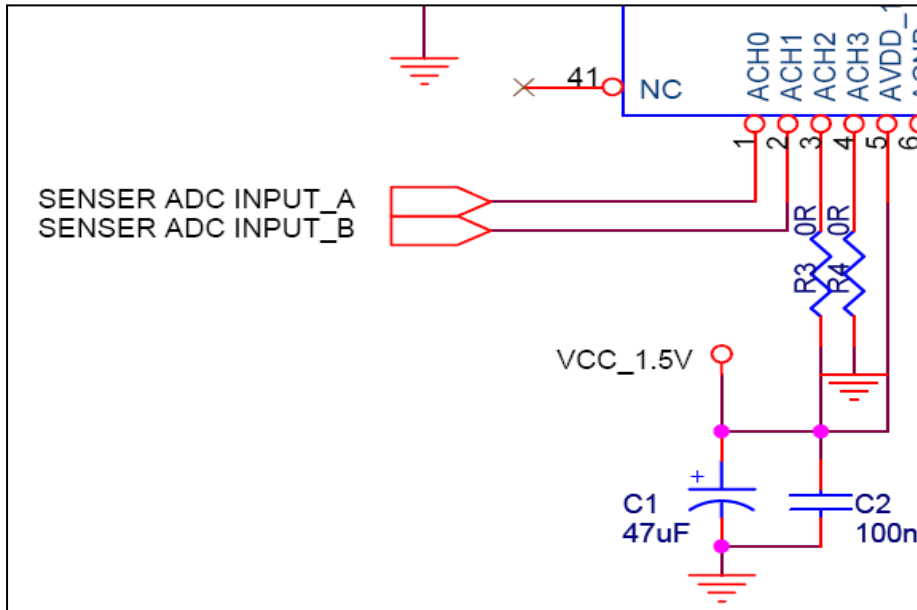

NOTE: Pin 3 connects AVDD_1.5V, Pin 4 connects Ground. This is for detailed sensing at pin1 and pin2.

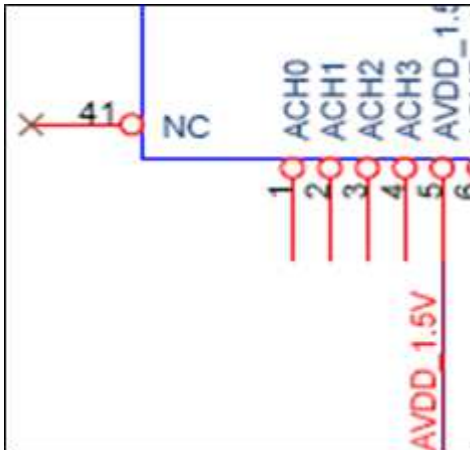

[Without sensing]

3.4. Power Supply Circuit

- AVDD 1.5V OUT : MIN 47uF
- DVDD 1.5V OUT : MIN 22uF
- VCC INPUT 3V : MIN 47uF

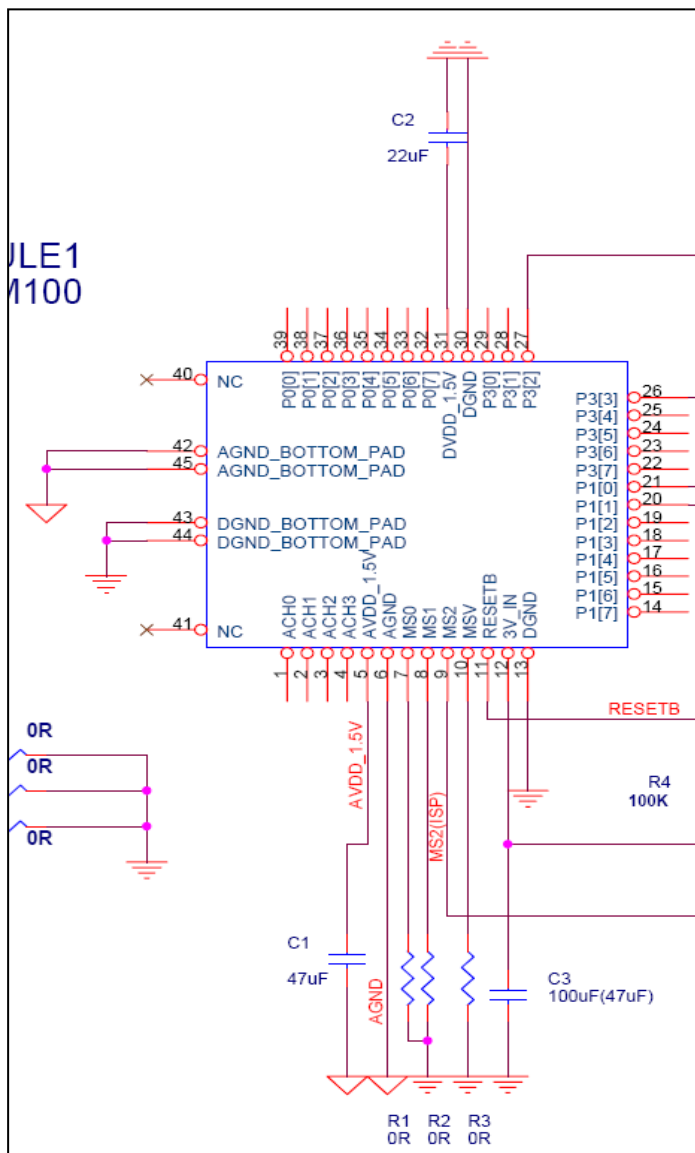

3.5. Ground

Isolation of Ground is different according as any application.

3.5.1. One Ground

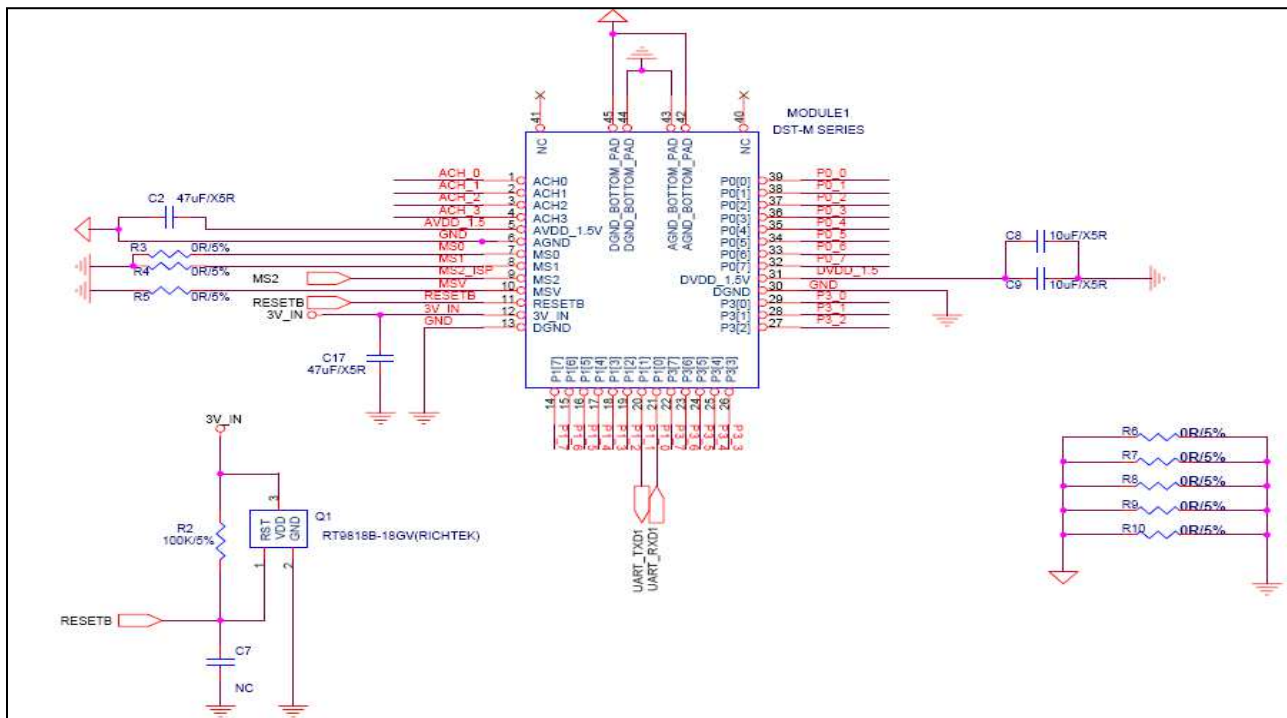

3.5.2. Two Ground

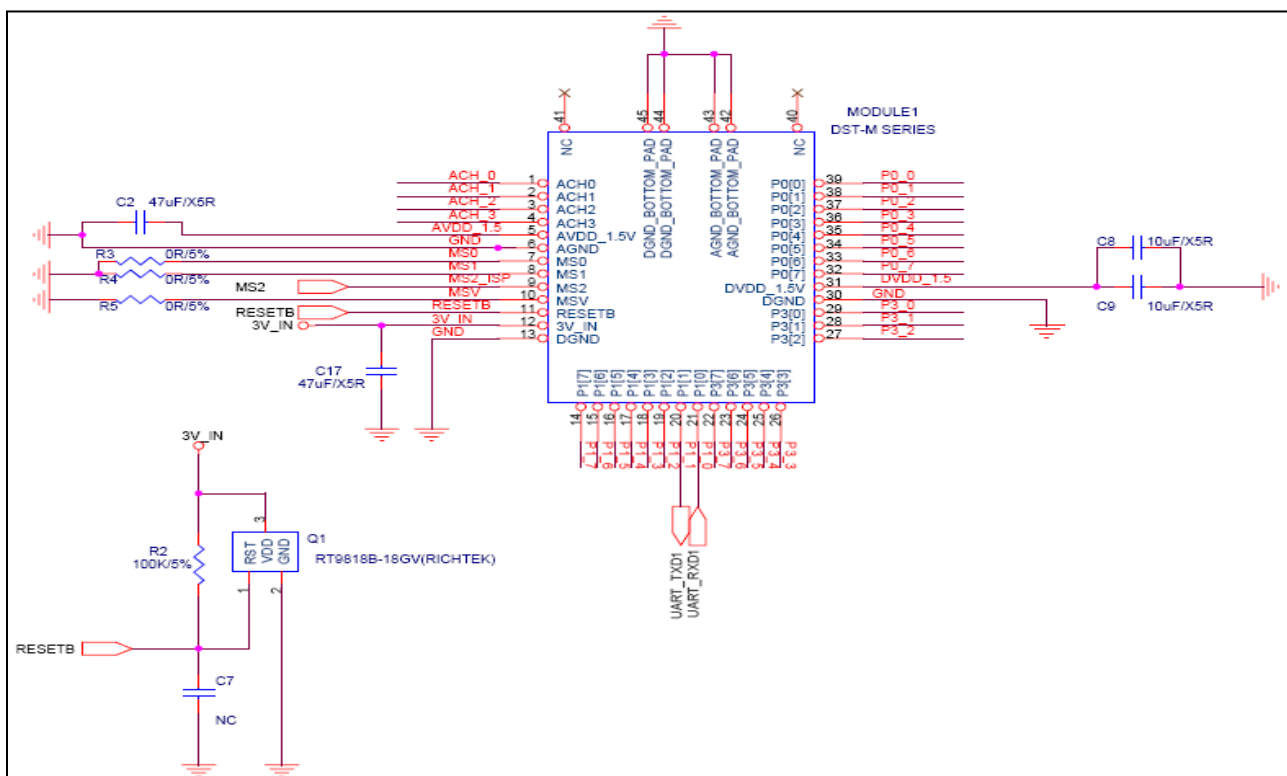

3.6. Reset circuit

Reset Circuit is designed for Flash protection of abnormal condition. Reset IC is RT9818B-18GV(1.8V, 50msec delay) detector of Richtek Technology Corporation.

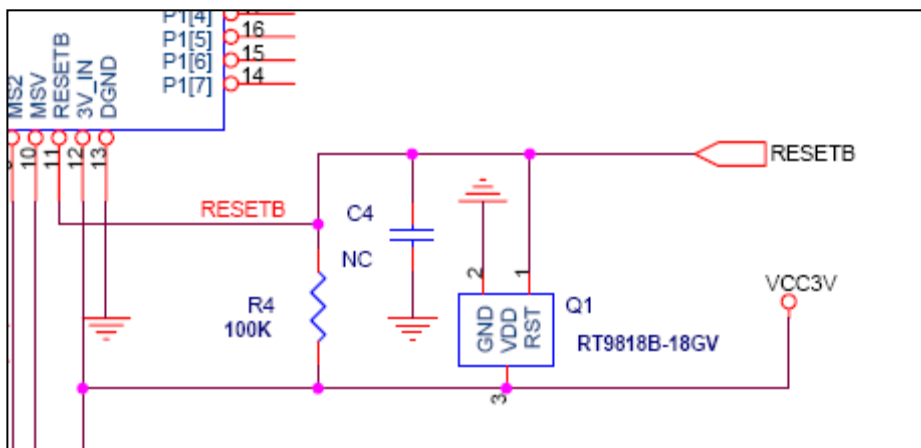

3.7. ISP

When ISP port is 'high(VCC)', ZS500M is to download mode.(MS0,MS1 = GND)
 When ISP port is 'LOW(OPEN or GND)', ZS500M is to normal operation mode.(MS0, MS1 = GND)
 (Pull down resistor 10k ohm in module)

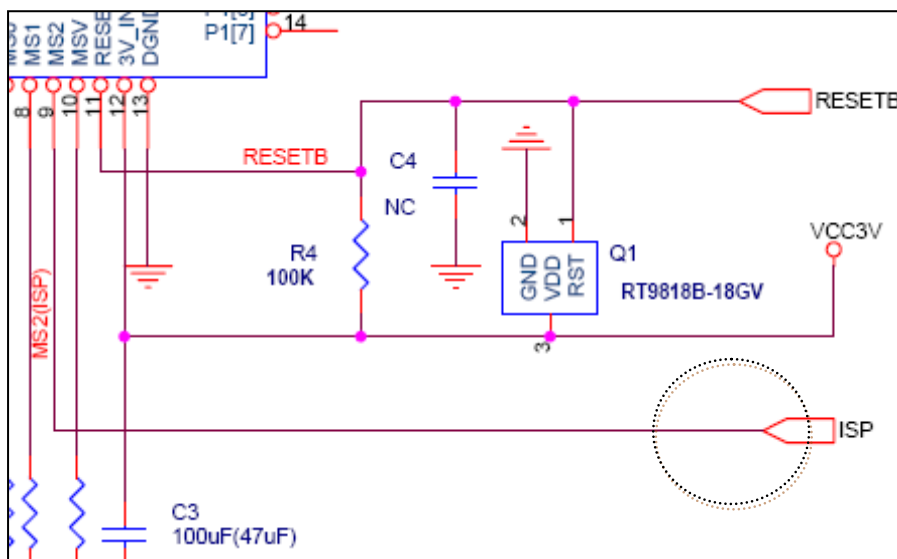

3.8. UART interface

P1.0 and P1.1 are Uart interface.

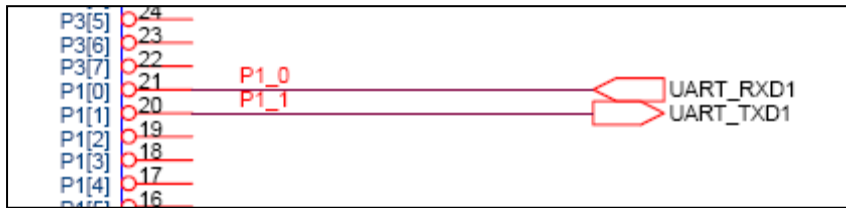

If another Uart needed, use P3.0(UART_RXD0) and P3.1(UART_TXD0).

3.9. Interrupt

R6 and R7, the pull up_ resistor of P3.2 and P3.3 are absolutely added for Power down mode.

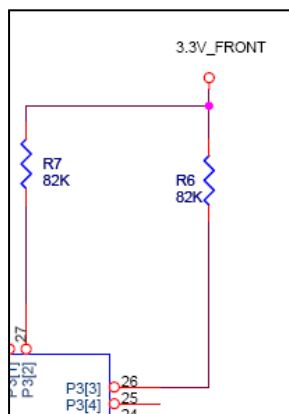

[Without interrupt signal]

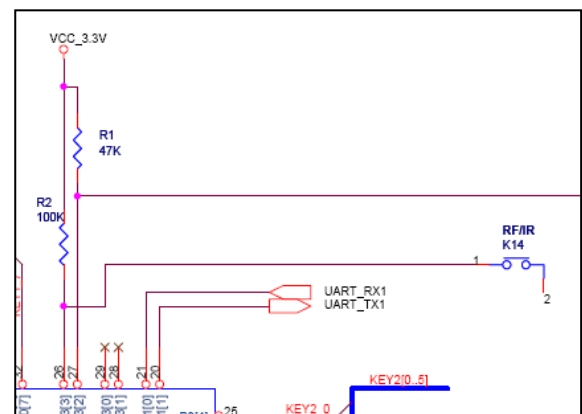

[With interrupt signal]

3.10. Remocon Circuit Example1

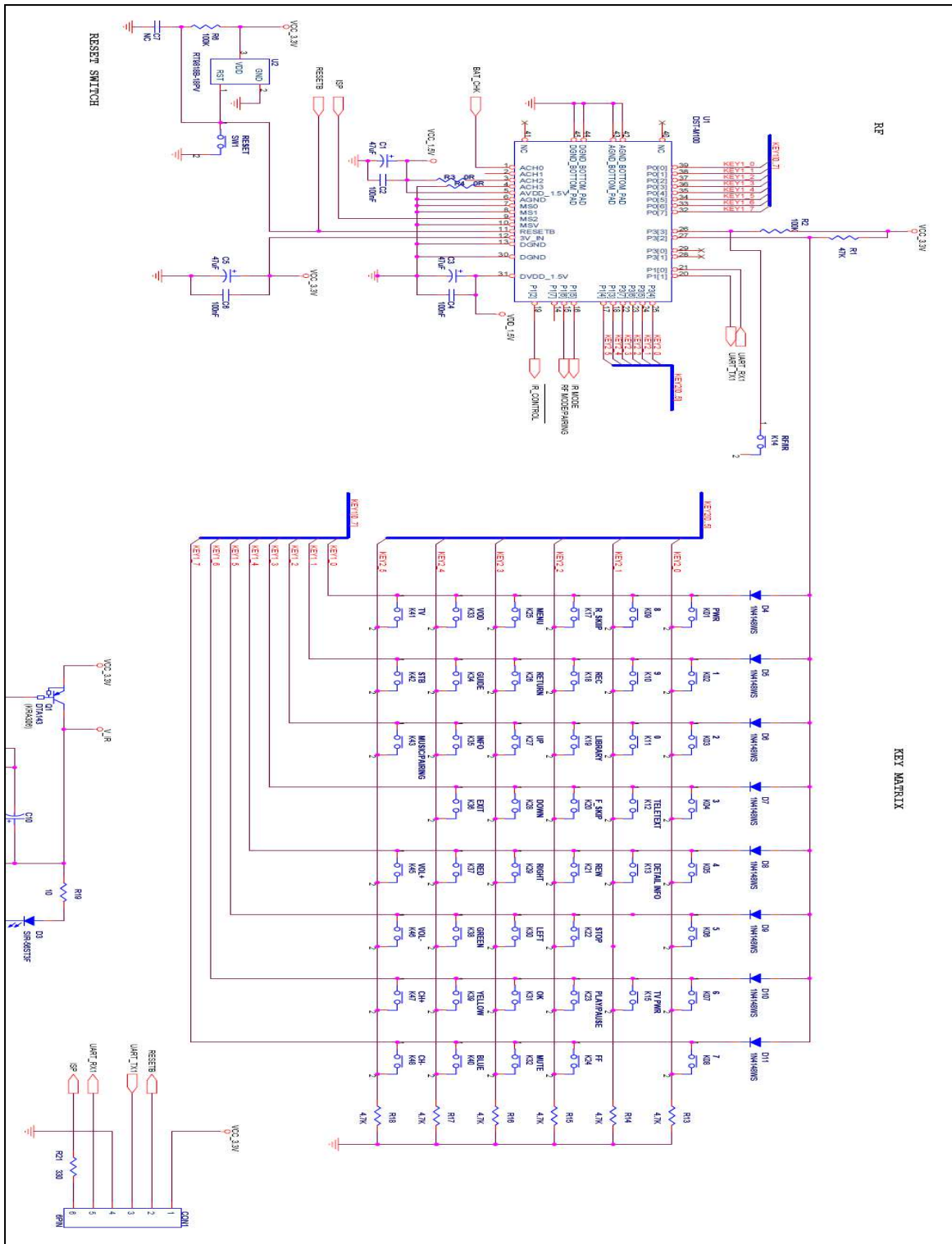

3.11. Application Circuit Example2

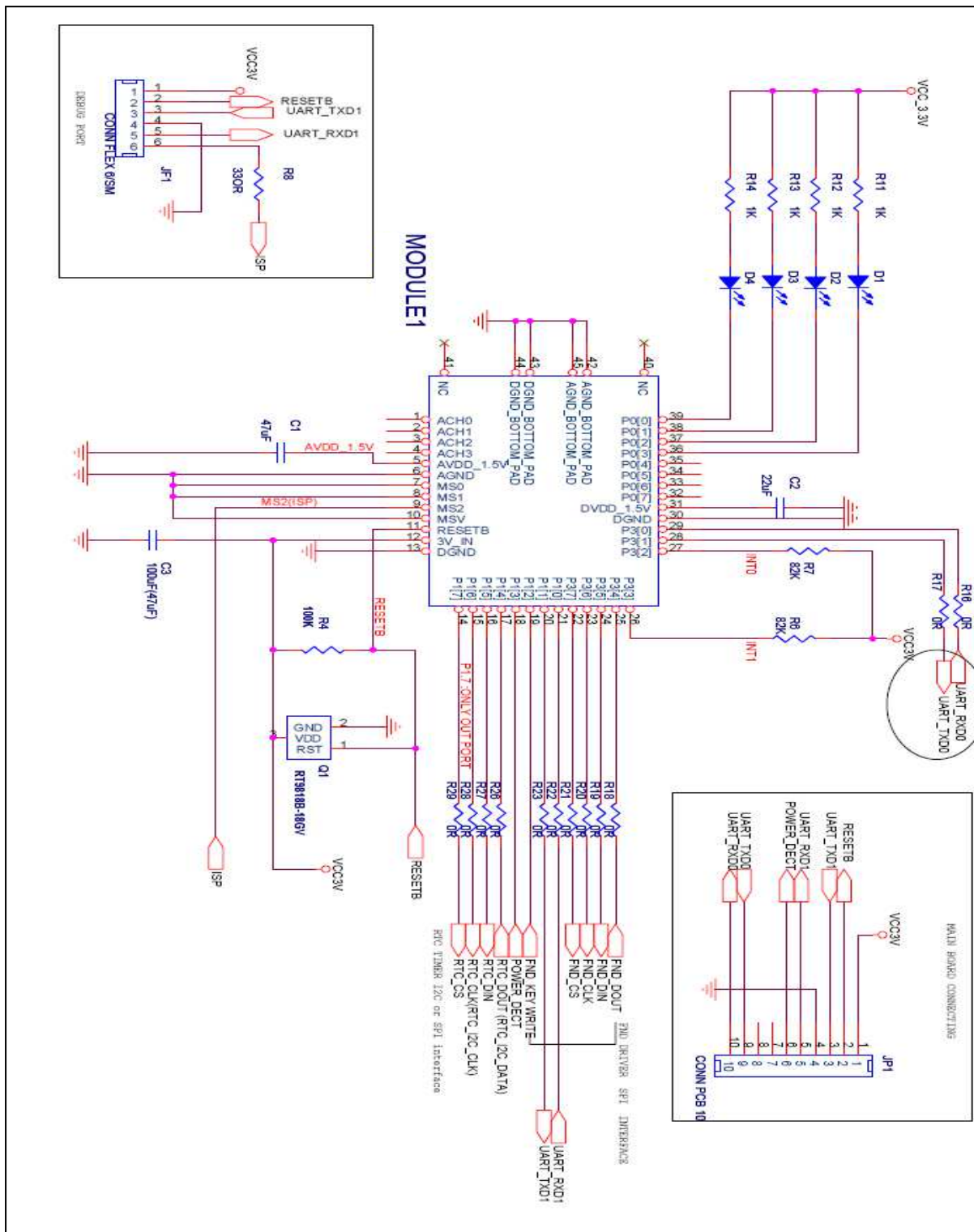

4. RELIABILITY & ANTENNA SPECIFICATION

4.1. Reliability

No.	Test item	Test condition
1	Reflow Thermal Cycle	Normal Pbfree reflow Condition.2 times
2	Thermal Shock Cycle	30min. at -40℃, 30min. at 85℃ , 100Cycles Recovery Time 2hours
3	Vibration Test	50Hz -> 500Hz -> 50Hz , 15min/Cycle X,Y,Z : Each 12 times [Total : 9hours]
4	High Temperature Storage Test	96 hours at 85℃±2℃, Recovery Time 2hours
5	Low Temperature Storage Test	96 hours at -40℃±2℃, Recovery Time 2hours
6	High Temperature & Humidity Storage Test	96 hours at 60℃±2℃ & 95%RH±2%RH. Recovery Time 2hours
7	Operating Temperature TEST	96hours at -40℃,85℃
8	High Temperature & Humidity Operating Test	24hours at 60℃ & 85%±2%RH.
9	Drop Test	Height min 76 ^{cm} , All sides onto Iron plate(T=min2mm).
10	ESD	HBM : ±2000V MM : 150V CDM : 500V

4.2. Specification of Antenna

ITEM	UNIT	MIN	TYP	MAX
Frequency	MHz	2400		2500
V.S.W.R				2.0
Gain(AVG)	dBi	-2		
Maximum input power	W			1
Characteristics TYPE	Meander IFA			
Polarization	Vertical			
Radiated Pattern	Omni-directional			
Impedence	50			
SIZE	10.5X3.5X1.7tmm			

5. REFLOW PROFILE

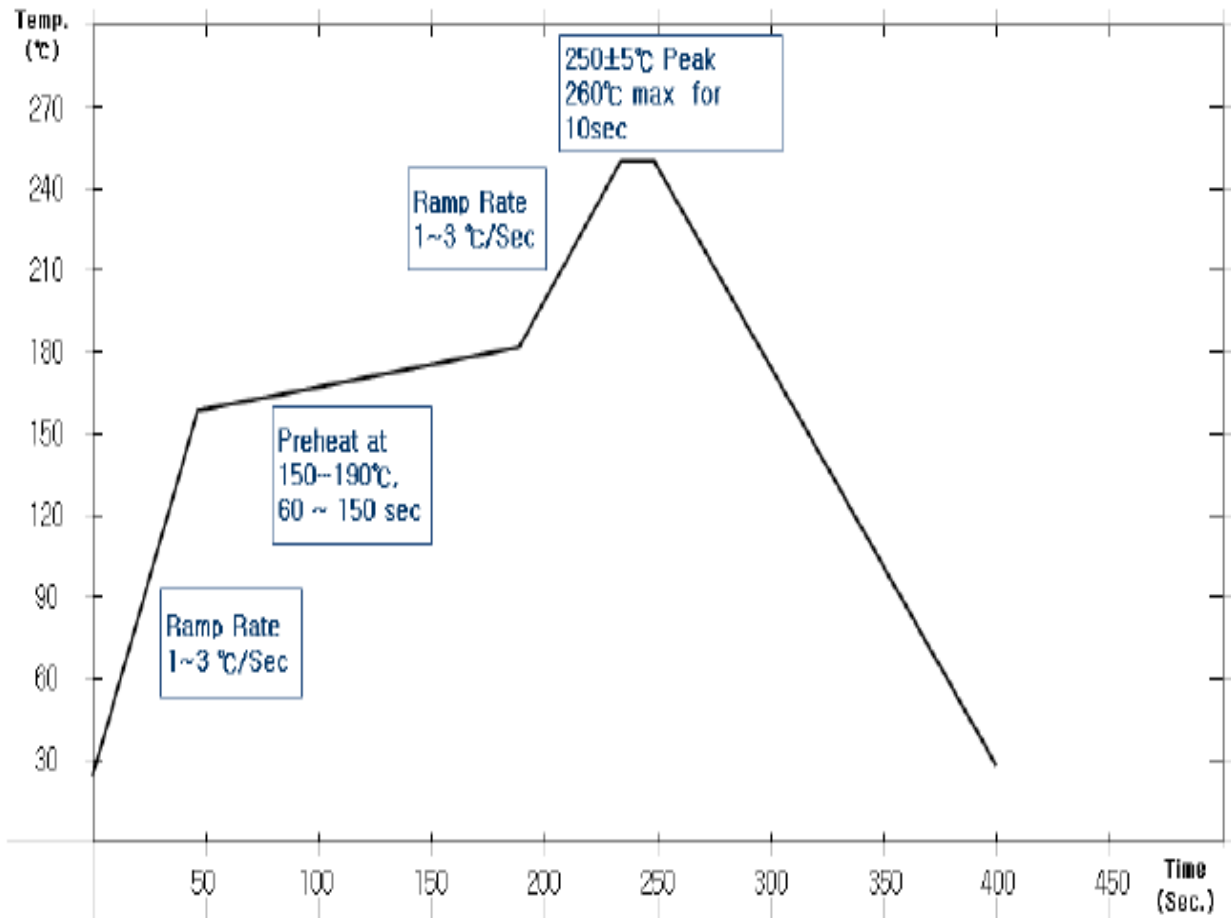

6. PACKAGE

6.1. Dimensions of tape

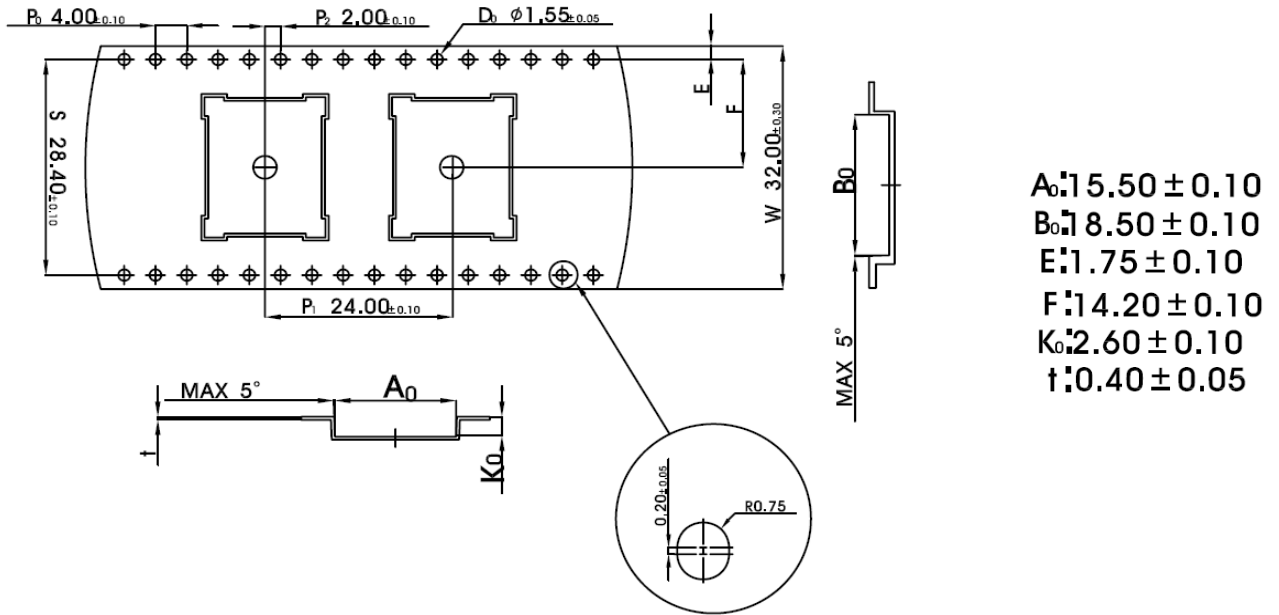

6.2. Dimensions of reel

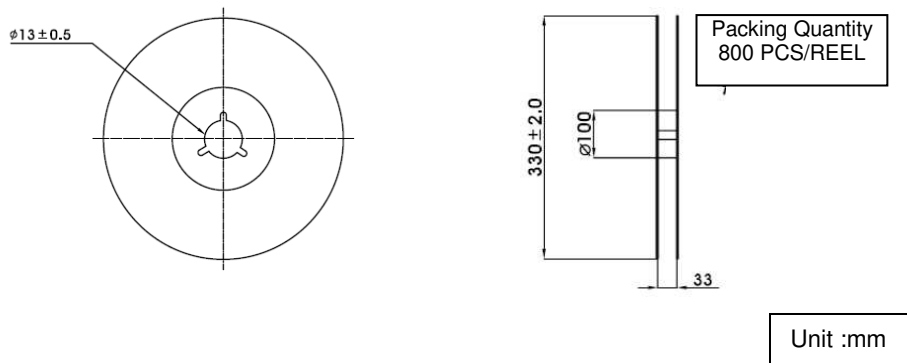

6.3. Taping style

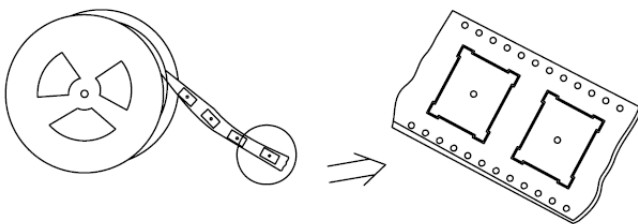

**RadioPulse Inc**

3rd Fl., Hans B/D II, 111-6 Seongnae-Dong,
Gangdong-Gu, Seoul, Korea, 134-883, Korea

URL: www.radiopulse.co.kr

Tel: +82-2-478-2963~5

Fax: +82-2-478-2967

sales@radiopulse.co.kr

About RadioPulse Inc.

RadioPulse is a Being Wireless solution provider offering wireless communication & network technologies and developing next generation wireless networking technologies.

The new wireless networking solutions envisioned by RadioPulse will enable user to enjoy wireless technologies with easy interface.

Founded in April of 2003, the company maintains it headquarters and R&D center in Seoul, Korea.

Copyright (c) 2012 RadioPulse. All rights reserved.