



Chipsmall Limited consists of a professional team with an average of over 10 year of expertise in the distribution of electronic components. Based in Hongkong, we have already established firm and mutual-benefit business relationships with customers from,Europe,America and south Asia,supplying obsolete and hard-to-find components to meet their specific needs.

With the principle of “Quality Parts,Customers Priority,Honest Operation,and Considerate Service”,our business mainly focus on the distribution of electronic components. Line cards we deal with include Microchip,ALPS,ROHM,Xilinx,Pulse,ON,Everlight and Freescale. Main products comprise IC,Modules,Potentiometer,IC Socket,Relay,Connector.Our parts cover such applications as commercial,industrial, and automotives areas.

We are looking forward to setting up business relationship with you and hope to provide you with the best service and solution. Let us make a better world for our industry!



## Contact us

Tel: +86-755-8981 8866 Fax: +86-755-8427 6832

Email & Skype: info@chipsmall.com Web: www.chipsmall.com

Address: A1208, Overseas Decoration Building, #122 Zhenhua RD., Futian, Shenzhen, China



# Features

# Regulated Converters

- 4:1 Wide Input Voltage Range
- 1.6kVDC Isolation
- UL Certified
- Efficiency up to 91%
- Six-Sided Continuous Shield
- No Minimum Load Required



# RP30-FW

**30 Watt**  
**2"x1"**  
**Single & Dual Output**



## Description

The RP30-FW series DC/DC converters are designed to meet to UL 60950-1 and to cUL 60950-1. This makes them ideal for all telecom and industrial applications where approved safety standards are required. The industry standard 2" x 1" package meets military standards for thermal shock and vibration tolerance.

## Selection Guide

Part Number	Input Voltage Range [VDC]	Output Voltage [VDC]	Output Current [mA]	Input <sup>(1)</sup> Current [mA]	Efficiency <sup>(1)</sup> typ. [%]	Max. Capacitive Load <sup>(2)</sup> [μF]
RP30-243.3SFW <sup>(4,5)</sup>	9-36	3.3	7500	1199	86	20000
RP30-2405SFW <sup>(4,5)</sup>	9-36	5	6000	1420	88	14400
RP30-2412SFW <sup>(4,5)</sup>	9-36	12	2500	1404	89	3000
RP30-2415SFW <sup>(4,5)</sup>	9-36	15	2000	1404	89	2000
RP30-483.3SFW <sup>(4,5)</sup>	18-75	3.3	7500	600	86	20000
RP30-4805SFW <sup>(4,5)</sup>	18-75	5	6000	710	88	14400
RP30-4812SFW <sup>(4,5)</sup>	18-75	12	2500	694	90	3000
RP30-4815SFW <sup>(4,5)</sup>	18-75	15	2000	687	91	2000
RP30-2405DFW <sup>(4,5)</sup>	9-36	±5	±3000	1420	88	±3000
RP30-2412DFW <sup>(4,5)</sup>	9-36	±12	±1250	1437	87	±2000
RP30-2415DFW <sup>(4,5)</sup>	9-36	±15	±1000	1437	87	±1300
RP30-4805DFW <sup>(4,5)</sup>	18-75	±5	±3000	710	88	±3000
RP30-4812DFW <sup>(4,5)</sup>	18-75	±12	±1250	710	88	±2000
RP30-4815DFW <sup>(4,5)</sup>	18-75	±15	±1000	710	88	±1300

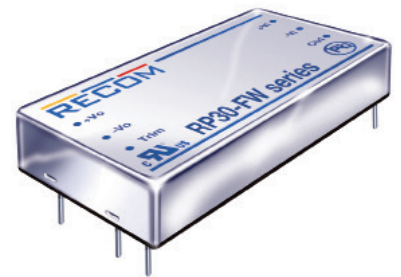

### Notes:

- Note1: Maximum value at nominal input voltage and full load.  
 Note2: Test by minimum Vin and constant resistor load.



## Model Numbering

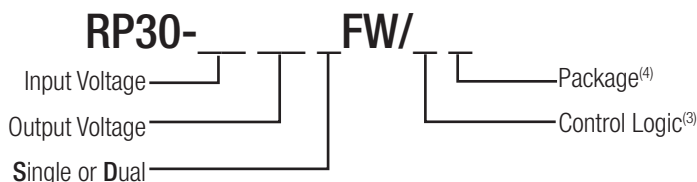

### Ordering Examples

- RP30-2405SFW = 24V Input, 5V Output, Positive Logic CTRL pin fitted  
 RP30-4812DFW/N-HC = 48V Input, ±12V Output, Negative Logic CTRL pin fitted, Heat-sink fitted

### Notes:

- Note3: no suffix for CTRL function with Positive Logic (1=ON, 0=OFF)  
 add "N" for CTRL function with Negative Logic (0=ON, 1=OFF)  
 Note4: add suffix -HC for premounted Heat-sink and clips

UL60950-1 Certified

**Specifications** measured at Ta = 25°C, nominal input voltage, full load otherwise noted

**BASIC CHARACTERISTICS**

Parameter	Condition	Min.	Typ.	Max.
Input Voltage Range	nom. Vin= 24V nom. Vin= 48V	9VDC 18VDC	24VDC 48VDC	36VDC 75VDC
Under Voltage Lockout (UVLO)	Vin = 24V DC-DC ON DC-DC OFF		8VDC	9VDC
	Vin = 48V DC-DC ON DC-DC OFF		16VDC	18VDC
Input Filter				Pi-Type
Input Reflected Ripple Current <sup>(5)</sup>	nominal Vin and full load		20mA <sub>p-p</sub>	
Input Surge Voltage	Vin= 24V, 100ms max. Vin= 48V, 100ms max.			50VDC 100VDC
Start-up time	Power up Remote ON/OFF		30ms 30ms	
Operating Frequency Range		387kHz	430kHz	473kHz
Minimum Load		0%		
Ripple and Noise	20MHz bandwidth with a 1µF/50V MLCC 3.3V <sub>out</sub> , 5V <sub>out</sub> 12V <sub>out</sub> , 15V <sub>out</sub>		100mV <sub>p-p</sub> 150mV <sub>p-p</sub>	
Remote ON/OFF <sup>(6)</sup>	Positive Logic DC-DC ON DC-DC OFF			Open or 3.0V < Vr < 12V Short or 0V < Vr < 1.2V
	Negative Logic DC-DC ON DC-DC OFF			Short or 0V < Vr < 1.2V Open or 3.0V < Vr < 12V
Input current of Remote pin (CTRL)	DC-DC OFF		3mA	
	DC-DC ON	-0.5mA		0.5mA

**Notes:**

Note5: Simulated source impedance of 12µH. 12µH inductor in series with +Vin.

Note6: The ON/OFF control function can be positive or negative logic. The pin voltage is referenced -Vin pin.

**RP30-2405SFV**

**Efficiency vs. Output Current**

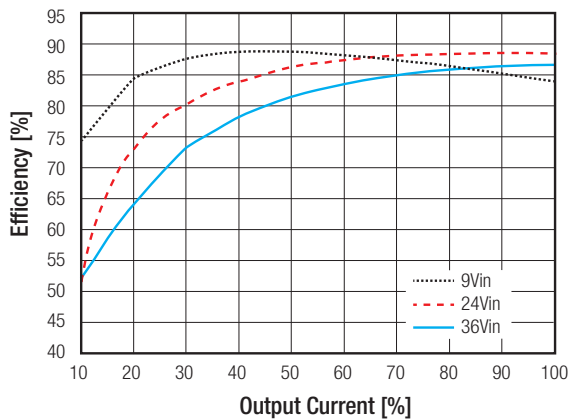

**Efficiency vs. Input Voltage**

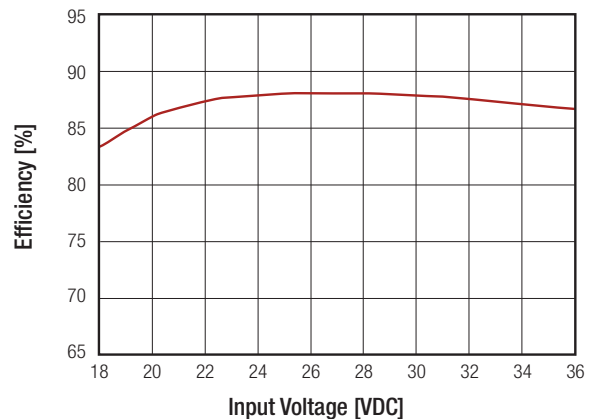

continued on next page

**Specifications** measured at Ta = 25°C, nominal input voltage, full load otherwise noted

**RP30-4805SFW**

**Efficiency vs. Output Current**

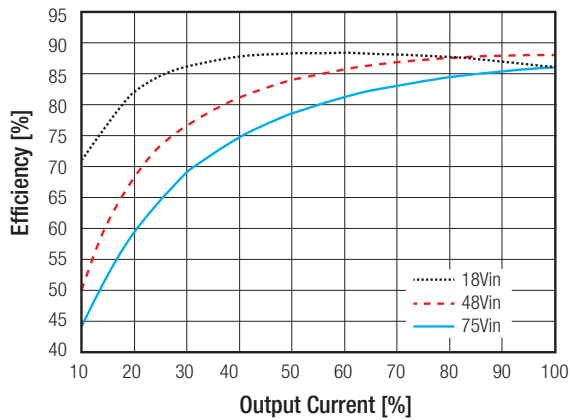

**Efficiency vs. Input Voltage**

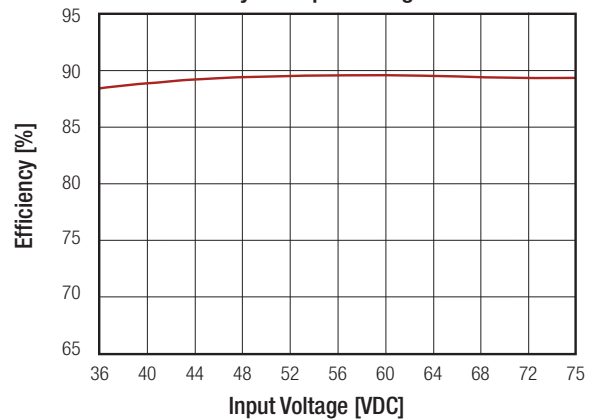

**REGULATIONS**

Parameter	Condition	Value	
Output Voltage Accuracy		±1% max.	
Voltage Adjustability	Single	±10% max.	
Line Voltage Regulation	low line to high line at full load	±0.2% max.	
Load Voltage Regulation	no load to full load	Single Dual	±0.5% ±1.0%
Cross Regulation	asymmetrical 25% <-> 100% load	±5%	
Transient Response recovery time	25% load step change	250µs typ.	

**External Output Trimming**

**Output Voltage Trimming**

Single output Powerline converters offer the feature of trimming the output voltage over a certain range around the nominal value by using external trim resistors. No general equation can be given for calculating the trim resistors, but the following trimtables give typical values for choosing these trimming resistors. If voltages between the given trim points are required, extrapolate between the two nearest given values to work out the resistor required or use a variable resistor to set the output voltage. Output can be externally trimmed by using the method shown below.

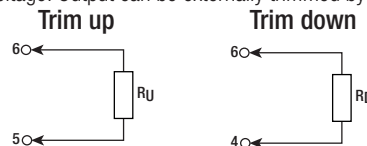

**RP30-xx3.3SFW**

Trim up	1	2	3	4	5	6	7	8	9	10	%
Vout =	3.333	3.366	3.399	3.432	3.465	3.498	3.531	3.564	3.597	3.63	Volts
R <sub>u</sub> =	57.93	26.16	15.58	10.28	7.11	4.99	3.48	2.34	1.46	0.75	kOhms
Trim down	1	2	3	4	5	6	7	8	9	10	%
Vout =	3.267	3.234	3.201	3.168	3.135	3.102	3.069	3.036	3.003	2.97	Volts
R <sub>d</sub> =	69.47	31.23	18.49	12.12	8.29	5.74	3.92	2.56	1.50	0.65	kOhms

**RP30-xx05SFW**

Trim up	1	2	3	4	5	6	7	8	9	10	%
Vout =	5.05	5.01	5.15	5.20	5.25	5.30	5.35	5.4	5.45	5.50	Volts
R <sub>u</sub> =	36.57	16.58	9.92	6.58	4.59	3.25	2.30	1.59	1.03	0.59	kOhms
Trim down	1	2	3	4	5	6	7	8	9	10	%
Vout =	4.95	4.90	4.85	4.80	4.75	4.70	4.65	4.60	4.55	4.50	Volts
R <sub>d</sub> =	45.53	20.61	12.31	8.15	5.66	4.00	2.81	1.92	1.23	0.68	kOhms

**Specifications** measured at Ta = 25°C, nominal input voltage, full load otherwise noted

RP30-xx12SFW											
Trim up	1	2	3	4	5	6	7	8	9	10	%
Vout =	12.12	12.24	12.36	12.48	12.60	12.72	12.84	12.96	13.08	13.20	Volts
R <sub>u</sub> =	367.91	165.95	98.64	64.98	44.78	31.32	21.70	14.49	8.88	4.39	kOhms
Trim down	1	2	3	4	5	6	7	8	9	10	%
Vout =	11.88	11.76	11.64	11.52	11.40	11.28	11.16	11.04	10.92	10.8	Volts
R <sub>o</sub> =	460.99	207.95	123.60	81.42	56.12	39.25	27.20	18.16	11.13	5.51	kOhms
RP30-xx15SFW											
Trim up	1	2	3	4	5	6	7	8	9	10	%
Vout =	15.15	15.3	15.45	15.60	15.75	15.90	16.05	16.20	16.35	16.50	Volts
R <sub>u</sub> =	404.18	180.59	106.06	68.80	46.44	31.53	20.88	12.90	6.69	1.72	kOhms
Trim down	1	2	3	4	5	6	7	8	9	10	%
Vout =	14.85	14.70	14.55	14.40	14.25	14.10	13.95	13.80	13.65	13.50	Volts
R <sub>o</sub> =	499.82	223.41	131.27	85.20	57.56	39.14	25.97	16.10	8.42	2.282	kOhms

PROTECTIONS			
Parameter	Condition	Value	
Short Circuit Protection (SCP)		continuous, automatic recovery	
Over Voltage Protection (OVP)	Zener Diode Clamp	3.3Vout	3.9VDC
		5Vout	6.2VDC
		12Vout	15VDC
		15Vout	18VDC
Over Load Protection (OLP)	% of Iout rated	150% typ.	
Over Temperature Protection (OTP)		115°C typ.	
Isolation Voltage	I/P to O/P	1.6kVDC/ 1 minute	
	I/P (O/P) to case	1.6kVDC/ 1 minute	
Isolation Resistance	500VDC	1GΩ min.	
Isolation Capacitance		1500pF max.	
<b>Notes:</b> Note7: This power module is not internally fused. An input line fuse must always be used.			

ENVIRONMENTAL		
Parameter	Condition	Value
Operating Temperature Range	without derating	-40°C to +62°C
	with derating	-40°C to +101°C
Maximum Case Temperature		+105°C max.
Temperature Coefficient		±0.02%/°C max.
Thermal Impedance	natural convection (20LFM) without Heat-sink	12°C/Watt
	natural convection (20LFM) with Heat-sink	10°C/Watt
Operating Humidity		5% - 95% RH
Thermal Shock		MIL-STD-810F
Vibration		MIL-STD-810F
MTBF	MIL-HDBK-217F	1288 x 10 <sup>3</sup> hours
	Bellcore TR-NWT-000332®	3163 x 10 <sup>3</sup> hours
continued on next page		

**Specifications** measured at Ta = 25°C, nominal input voltage, full load otherwise noted

Derating Graph<sup>(9)</sup>

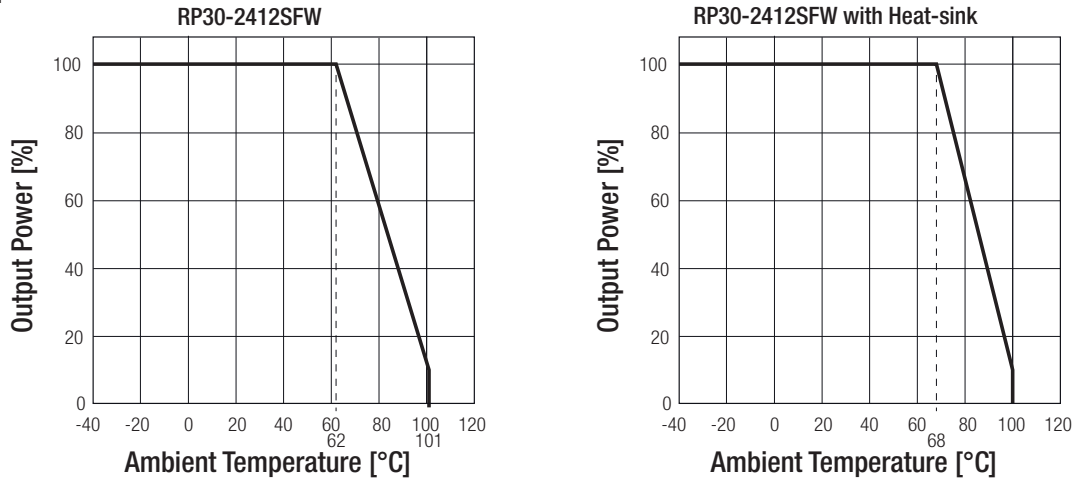

**Notes:**

Note8: BELLCORE TR-NWT-000332. Case I: 50% Stress, Temperature at 40°C (Ground fixed and controlled environment)  
MIL-HDBK-217F Notice2 @ TA= 25°C, Full load (Ground, Benign, controlled environment)

Note9: Derating graphs are valid only for the shown part numbers. If you need detailed derating-information about a part-number not shown here please contact our technical support service at techsupportAT@recom-power.com

**SAFETY AND CERTIFICATIONS**

Certificate Type (Safety)	Report / File Number	Standard
UL General Safety	E196683	UL60950-1 1st. Ed.: 2003 C22.2 No. 60950 1st. Ed.: 2003
EMC Compliance	Condition	Standard / Criterion
EMI Standard <sup>(10)</sup>	with external filter	EN55022, Class A or B
ESD	Air ±8kV and Contact ±6kC	EN61000-4-2, Criteria A
Radiated Immunity	10 V/m	EN61000-4-3, Criteria A
Fast Transient <sup>(11)</sup>	±2kV	EN61000-4-4, Criteria A
Surge <sup>(11)</sup>	±1kV	EN61000-4-5, Criteria A
Conducted Immunity	10 Vr.m.s	EN61000-4-6, Criteria A

**Notes:**

Note10: The standard modules meet EMI Class A or Class B with external components, see filter suggestions below.

Note11: An external input filter capacitor is required if the module has to meet EN61000-4-4, EN61000-4-5. The filter capacitor Recom suggests: 12VDC & 24VDC input Nippon chemi-con KY series, 330µF/50V  
48VDC input Nippon chemi-con KY series, 220µF/100V

**EMI Filtering Class A**

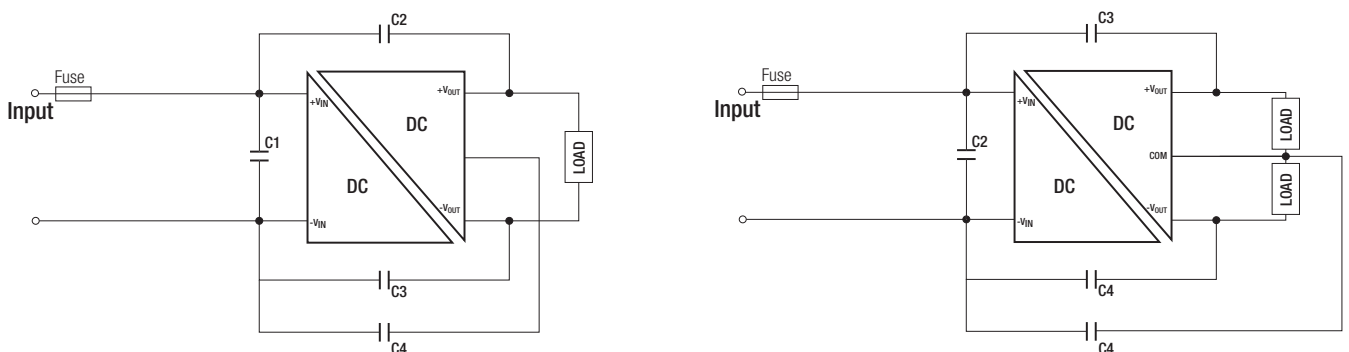

continued on next page

Specifications measured at Ta = 25°C, nominal input voltage, full load otherwise noted

MODEL	C1	C2/C3/C4
RP30-24xxSFW	4.7µF/50V	1000pF/2kV
RP30-24xxDFW	1812 MLCC	1808 MLCC
RP30-48xxSFW	2.2µF/100V	1000pF/2kV
RP30-48xxDFW	1812 MLCC	1808 MLCC

### EMI Filtering Class B

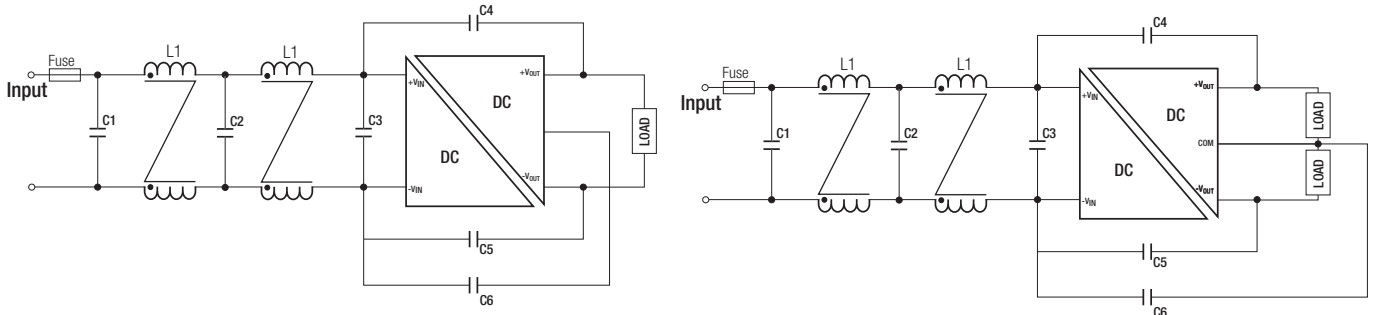

MODEL	C1/C2/C3	C4/C5/C6	L1	L2
RP30-24xxSFW	4.7µF/50V	1000pF/2kV	CMC: 33.3µH ref.: WE 744842932 ref.: CMC-09	CMC: 55µH ref.: WE 744290560 ref.: CMC-10
RP30-24xxDFW	1812 MLCC	1808 MLCC		
RP30-48xxSFW	2.2µF/100V	1000pF/2kV	CMC: 33.3µH ref.: WE 744842932 ref.: CMC-09	CMC: 55µH ref.: WE 744290560 ref.: CMC-10
RP30-48xxDFW	1812 MLCC	1808 MLCC		

### DIMENSIONS and PHYSICAL CHARACTERISTICS

Parameter	Type	Value
Material	Case	Nickel coated copper
	Base	FR4 PCB
	Potting	Epoxy (UL94-V0)
Package Dimensions (LxWxH)	without Heat-sink	50.8 x 25.4 x 10.2mm
	with Heat-sink	56.8 x 25.4 x 16.8mm
Package Weight	without Heat-sink	30.5g
	with Heat-sink	41.39g

### Dimension Drawing (mm)

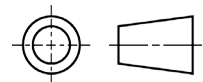
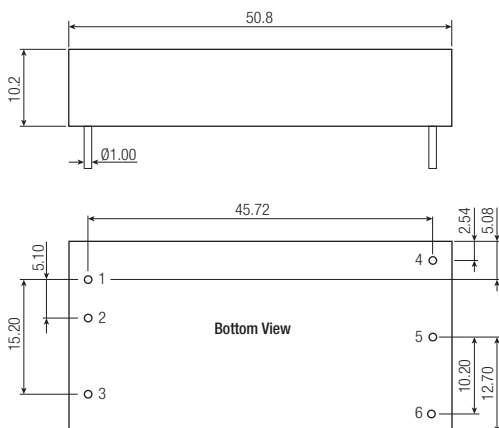

### Pin Connections

Pin #	Single	Dual
1	+Vin	+Vin
2	-Vin	-Vin
3	CTRL	CTRL
4	+Vout	+Vout
5	-Vout	Com
6	Trim	-Vout

Pin Pitch Tolerance  $\pm 0.25\text{mm}$   
 Pin dimension tolerance  $\pm 0.1\text{mm}$   
 Tolerance: X.X  $\pm 0.5\text{mm}$   
 X.XX  $\pm 0.25\text{mm}$

continued on next page

**Specifications** measured at Ta = 25°C, nominal input voltage, full load otherwise noted

Dimension Drawing (mm) with Heat-sink

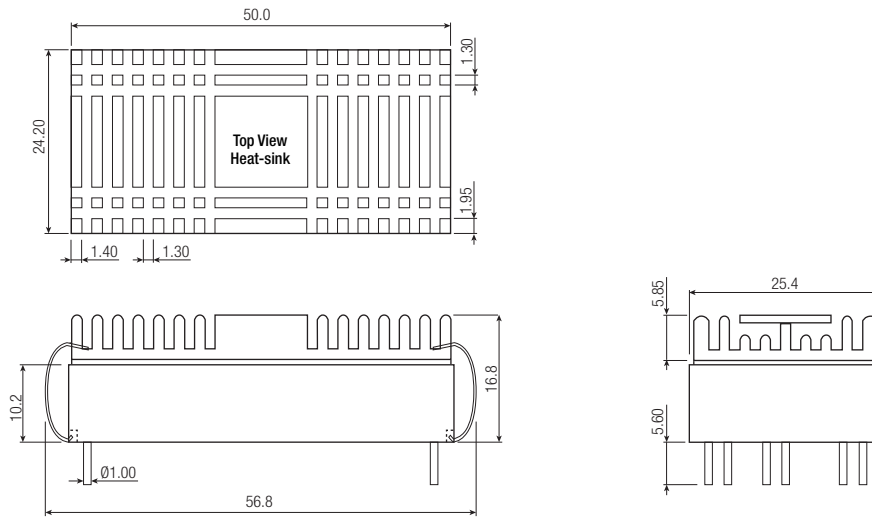

**PACKAGING INFORMATION**

Parameter	Type	Value
Packaging Quantity	without Heat-sink	9pcs.
	with Heat-sink	20pcs.
Storage Temperature Range		-55°C to +125°C
Storage Humidity		5% - 95% RH