



Chipsmall Limited consists of a professional team with an average of over 10 year of expertise in the distribution of electronic components. Based in Hongkong, we have already established firm and mutual-benefit business relationships with customers from,Europe,America and south Asia,supplying obsolete and hard-to-find components to meet their specific needs.

With the principle of "Quality Parts,Customers Priority,Honest Operation,and Considerate Service",our business mainly focus on the distribution of electronic components. Line cards we deal with include Microchip,ALPS,ROHM,Xilinx,Pulse,ON,Everlight and Freescale. Main products comprise IC,Modules,Potentiometer,IC Socket,Relay,Connector.Our parts cover such applications as commercial,industrial, and automotives areas.

We are looking forward to setting up business relationship with you and hope to provide you with the best service and solution. Let us make a better world for our industry!



## Contact us

Tel: +86-755-8981 8866 Fax: +86-755-8427 6832

Email & Skype: info@chipsmall.com Web: www.chipsmall.com

Address: A1208, Overseas Decoration Building, #122 Zhenhua RD., Futian, Shenzhen, China



# New Connectors For Low Profile Power Supply

## RP34L Series

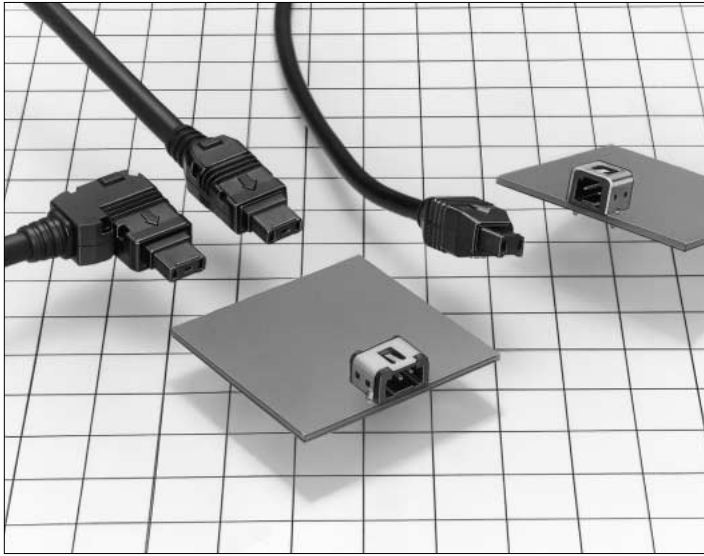

Receptacle installed height

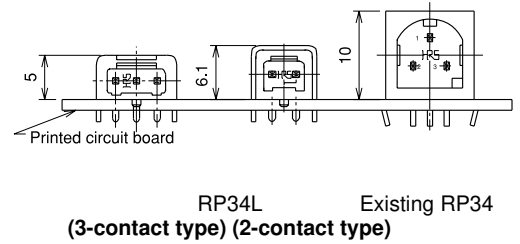

Fig.-①

### ■Features

#### 1. Low profile:

These receptacles are designed with their installation heights to be shorter than those of conventional RP34 series, such as 6.1mm (for 2-core type) and 5mm (for 3-core type). (See Fig.-1.)

#### 2. Space saving:

Both 2 and 3 position receptacles are miniaturized to 7mm in depth, resulting in a small board mounting area. Please refer Fig.-2 and Fig.-3.

#### 3. With snap-lock mechanism:

Audible click when connector is fully mated.

#### 4. Tight fit:

Designed to fit snugly in all three directions.

#### 5. Sequence structure:

The 3 contact type has sequenced mating so that one pin makes contact as a ground terminal before the other contacts engage.

#### 6. No Mismatching

Two polarized keys prevent any insertion error.

#### 7. Ease of Mating

An arrow on the top of the plug shows the proper direction for insertion.

### ■Applications

Notebook PCs, portable remote terminals, AV equipment, etc.

Mated Size

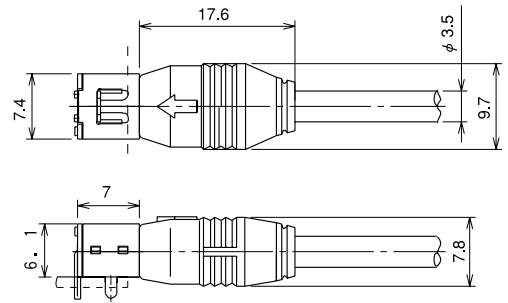

RP34L-5PA-2SC(\*\*\*) & RP34L-5R-2PD

This 2 contact plug is an over-molded (i.e., cable-integrated form) type. Recommended cable diameter is  $\phi 3.5$ mm. Fig.-②

Mating Size

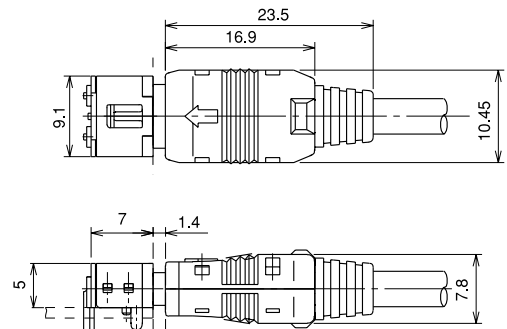

RP34L-5P-3SC & RP34L-5R-3PD

This 3-contact plug is a fabricated type. Recommended cable diameter is  $\phi 4$ mm. Fig.-③

## ■Product Specifications

RATINGS	Rated Current	5A	Available Temp. Range	-25℃~+85℃
	Rated Voltage	AC30V,DC42A	Storage Temp. Range	-10℃~+60℃

Description	Specifications	Requirements
1.contact resistance	30mΩ or less	Should be measured at DC 1A.
2.insulation resistance	1000mΩ or more	Should be measured at DC 100V.
3.voltage resistance	No flashover/dielectric	AC 150V for 1 minute
4.vibration resistance	4.vibration Breakdown No instantaneous electric Disconnection of 10μs or More	10~55Hz, one-sided amplitude 0.75mm, 3 directions for 2hours, respectively
5.temperature cycle	Insulation resistance:100mΩ or more	-55℃ for 30 min.→normal temp. for 10~15 min.→+85℃ for 30 min.→normal temp. for 10~15 min. 5 cycles
6.corrosion resistance	No excessive corrosion	For 48 consecutive hours in 5% salt water
7.Duration against consecutive plugging/unplugging.	Contact resistance:60mΩ or less	5,000 time

Note.1) Above-stated specifications are typical of this series. For part specific data, please consult factory.

## ■Material Quality

Description	Material	Processing	Remarks
2 position receptacle	Metal fixture	Phosphor bronze	
	Dielectric	Nylon resin	UL94HB
	Terminal	Brass	
2-position plug	Cover	Vinyl chloride resin	UL94V-0
	Insert insulator	Nylon resin	UL94HB
	Terminal	Phosphor bronze	
3-position receptacle	Metal fixture	Phosphor bronze	
	Insulator	PPS resin	UL94V-0
	Terminal	Brass	
3-position plug	Cover	Polycarbonate resin	UL94V-0
		Vinyl chloride	UL94V-0
	Insulator	PPS resin	UL94V-0
	Terminal	Phosphor bronze	

## ■Product Name Configuration

This is available for you to determine the product specifications from a part number, not to produce part numbers. When ordering, please select from existing part numbers shown in page 3-4 of this catalog.[For plugs, Hirose will produce cable assemblies to customer specifications. Please consult Hirose for quote.]

**RP34L - 5 PA - 2 SC (\*\*\*\*)**  

①
②
③
④
⑤
⑥

① Series name: RP34L	④ Number of positions: Shows the number of terminals. 2 contacts. 3 contacts
② Shell: 5-shell.size	
③ Type: Receptacle: R Assembled straight plug: P Assembled right angle plug: LP Cable-integrated forming straight plug: PA	⑤ Type of contact: PD: dip-solder male terminal SC: crimp-style female terminal
	⑥ Cable length:(****) depends on each cable.

■ Receptacles  
● 2-position

RP34L-5R-2PD

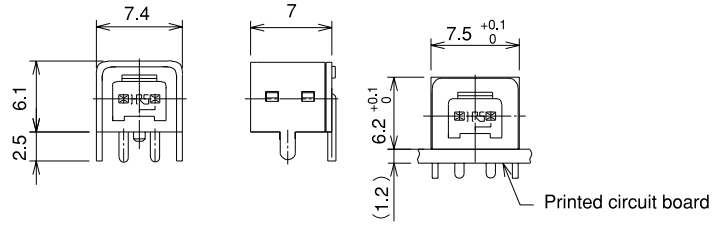

Recommended panel dimensions (reference)      Hole dimensions for a printed circuit board to be installed

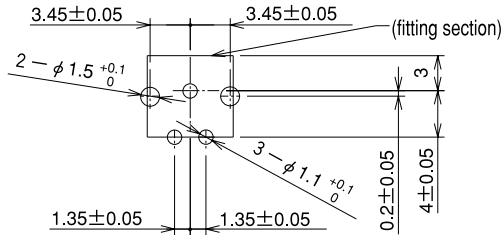
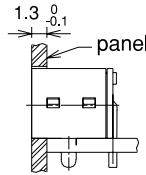

● 3-position

RP34L-5R-3PD

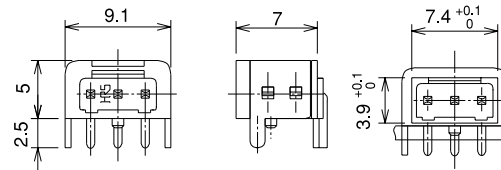

Recommended panel dimensions (reference)      Hole dimensions for a printed circuit board to be installed

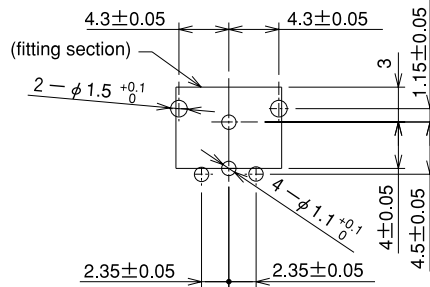
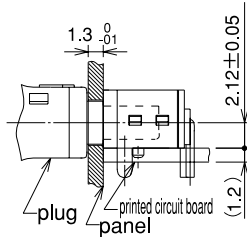

HRS No.	Parts No.
113-5154-6-00	RP34L-5R-2PD
113-5157-4-00	RP34L-5R-3PD

## Plugs

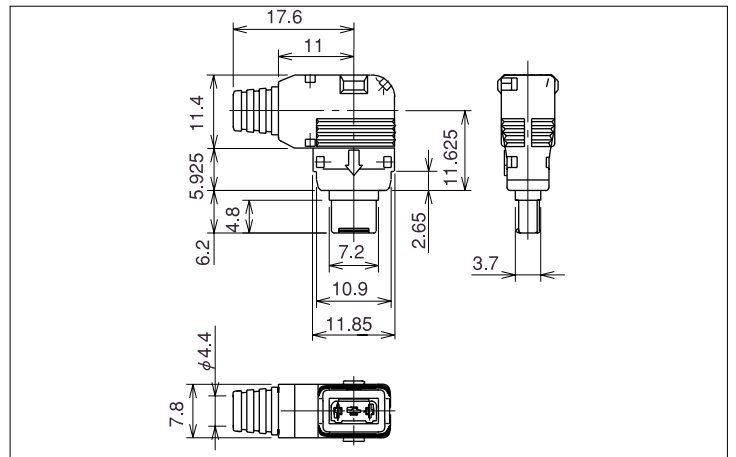
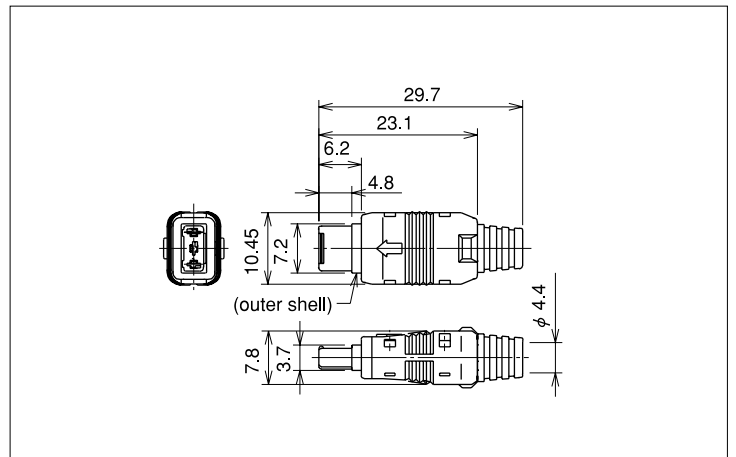
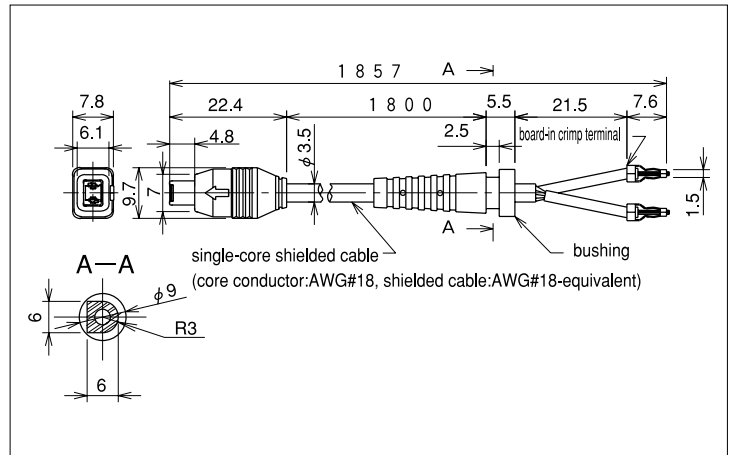

HRS No.	Parts No
113-5153-3-00	RP34L-5PA-2SC(1857)
113-5158-7-00	RP34L-5P-3SC
113-5161-1-00	RP34L-5LP-3SC

## ■Crimp Terminal

■RP34L-SC1-212(01)

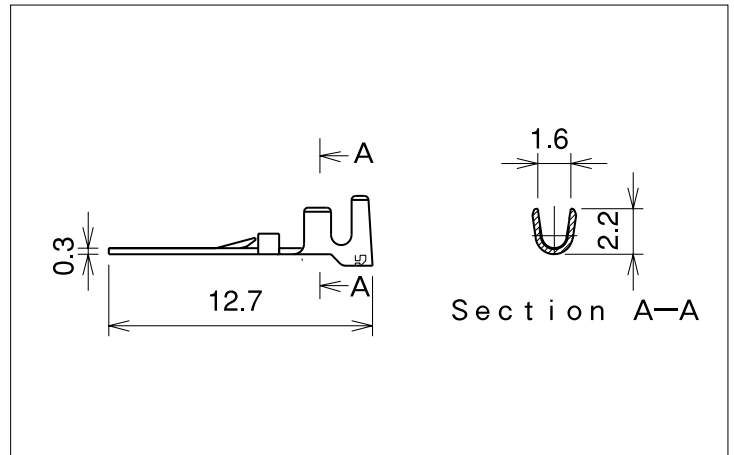
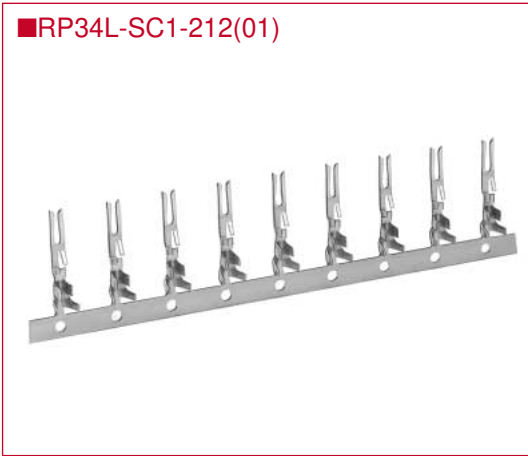

HRS No.	Parts No
113-5151-8-01	RP34L-SC1-212(01)

## ■Applicable Tools

TYPE	HRS No.	Parts No.	Conformant terminal	Conformant Cable
Manual crimping tool	—	HT-102/RP34L-SC1-212	RP34L-SC1-212(01)	AWG#18~#22
Crimper	Automatic	901-0005-4	CM-105	—
	Crimper body	901-2043-4	AP105-RP34L-SC1-212	RP34L-SC1-212(01)
Cable crimping tool	150-0074-1	RP34-TC-01	—	φ4
Drawing tool	150-0039-0	RP6-SC-TP	—	—

## ■Assembly Instructions(3-Position Plug)

### ●Straight Plug

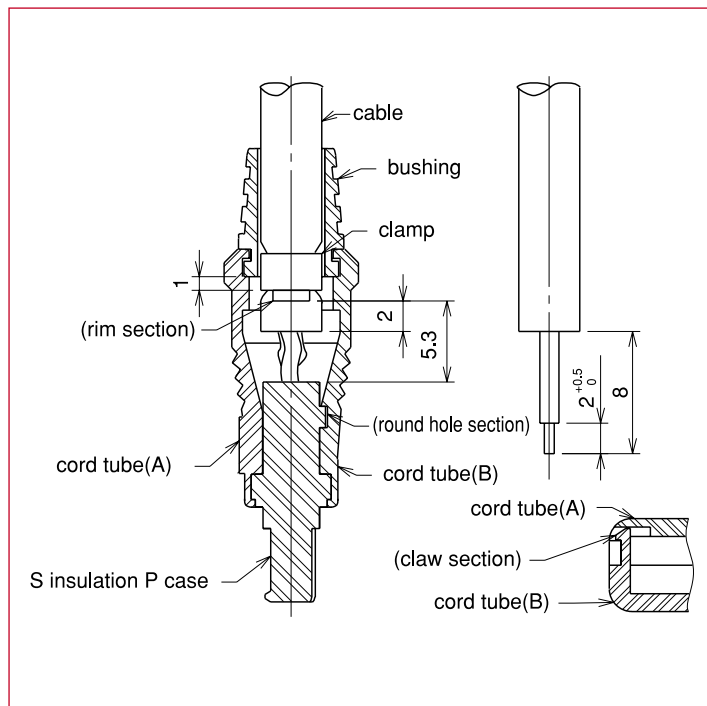

1. First, pull the bushing through the terminal-processed cable to crimp and wire that terminal.
2. Insert such crimped/wired terminal into the terminal hole of S insulation P case. Then verify that the crimp terminal is firmly engaged in the terminal hole of S insulation P case by pulling the cable slightly. In such cases as incorrect wiring, insert the drawing jig (RP6-SC-TP) from the fitting section to draw the terminal out of wiring side and rearrange it.
3. Next, crimp the clamp to the cable with an applicable tool (RP34-tc-01).
4. Install the convex section of S insulation P case in the cord tube(B) by adjusting to its round hole.
5. Then put the rim of clamp into the concave section of cord tube(B), and install bushing/clamp in cord tube(B).
6. Install cord tube(A) in cord tube(B). At that time, verify that four claw sections of cord tube(B) are mounted on the square hole section of cord tube(A).

### ●Right Angle Plug

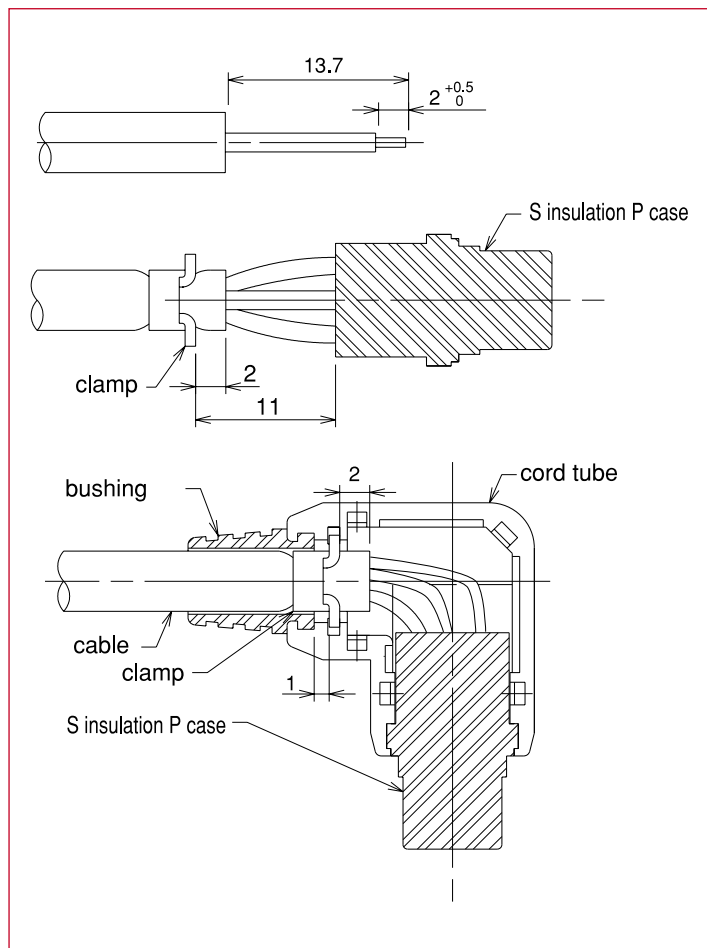

1. The right angle plug can also be assembled by using the same procedure as the straight plug.

## ■Precautions

1. Use the connector section with its panel held down so as not to have excessive load. For 2-contact type, hold the outer shell section of the receptacle, and for 3 contact type, the outer shell section of the plug.

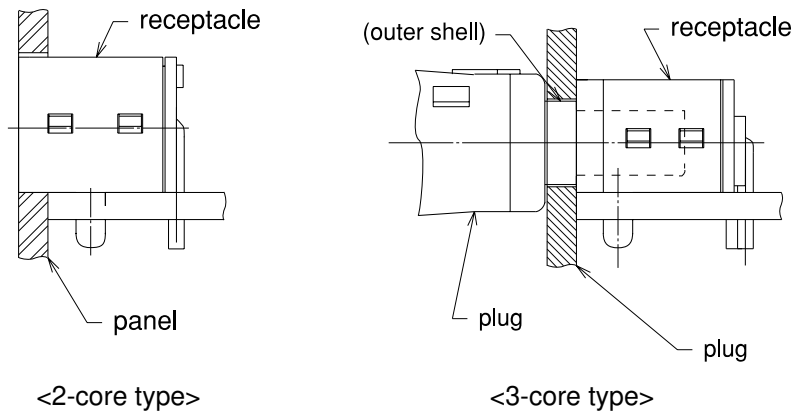

2. After connector assembly, cable must not be pulled over 30N in the arrow-indicated direction. Be careful not to add excessive tensile load because it will lead the damage of connectors.

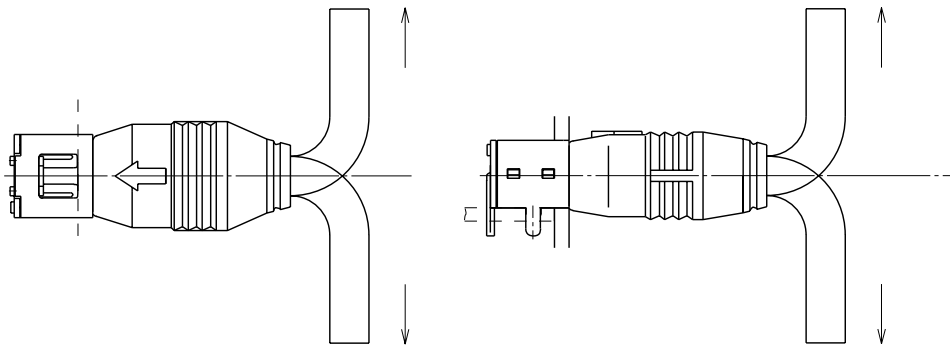



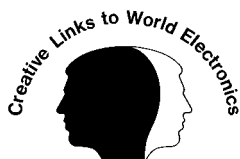

## **HIROSE ELECTRIC CO.,LTD.**

5-23,OSAKI 5-CHOME,SHINAGAWA-KU,TOKYO 141-8586,JAPAN

PHONE:3-3491-9741

FAX :3-3493-2933