



Chipsmall Limited consists of a professional team with an average of over 10 year of expertise in the distribution of electronic components. Based in Hongkong, we have already established firm and mutual-benefit business relationships with customers from,Europe,America and south Asia,supplying obsolete and hard-to-find components to meet their specific needs.

With the principle of “Quality Parts,Customers Priority,Honest Operation,and Considerate Service”,our business mainly focus on the distribution of electronic components. Line cards we deal with include Microchip,ALPS,ROHM,Xilinx,Pulse,ON,Everlight and Freescale. Main products comprise IC,Modules,Potentiometer,IC Socket,Relay,Connector.Our parts cover such applications as commercial,industrial, and automotives areas.

We are looking forward to setting up business relationship with you and hope to provide you with the best service and solution. Let us make a better world for our industry!



Contact us

Tel: +86-755-8981 8866 Fax: +86-755-8427 6832

Email & Skype: info@chipsmall.com Web: www.chipsmall.com

Address: A1208, Overseas Decoration Building, #122 Zhenhua RD., Futian, Shenzhen, China



Low Profile Connectors for AC power supply

RP34L Series

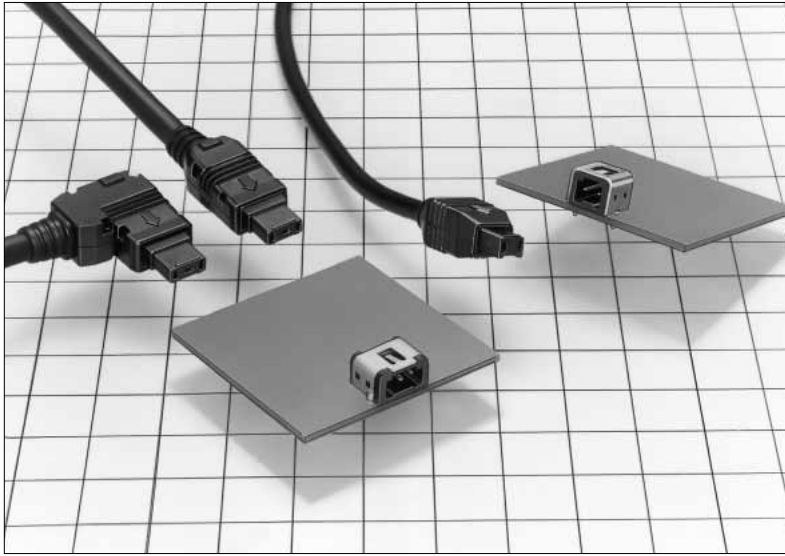

Receptacle installed height

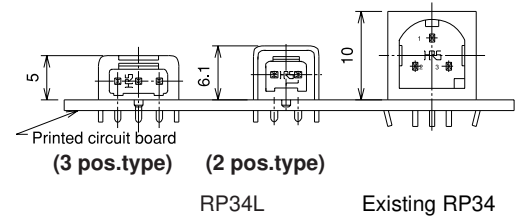

■Features

1. Low profile

Receptacles are designed with their installation heights to be shorter than those of conventional RP34 series.

2. Space saving

Both 2 and 3 position receptacles are miniaturized to 7mm length, resulting in a small board mounting area.

3. Snap-lock mechanism

Audible click when connector is fully mated.

4. Precise mated connection

Secure hold of the plug on au 3 axis.

5. Sequence mating

The 3 contact type has sequenced mating. One pin makes contact as a ground terminal before the other contacts.

6. No Mismatching

Two polarized keys prevent any insertion error.

7. Ease of Mating

An arrow on the top of the plug shows the proper direction for insertion.

■Applications

Notebook PCs, portable remote terminals, AV equipment, etc.

Mated dimensions

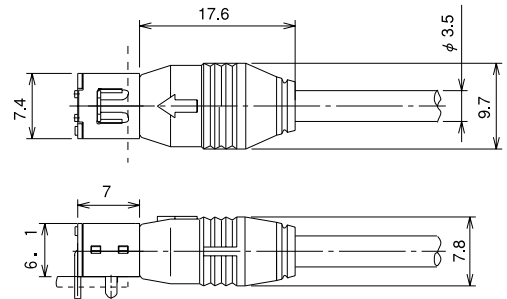

RP34L-5PA-2SC(***) & RP34L-5R-2PD

This 2 contact plug is an over-molded (i.e., cable-integrated form) type. Recommended cable diameter is 3.5mm dia.

Mated dimensions

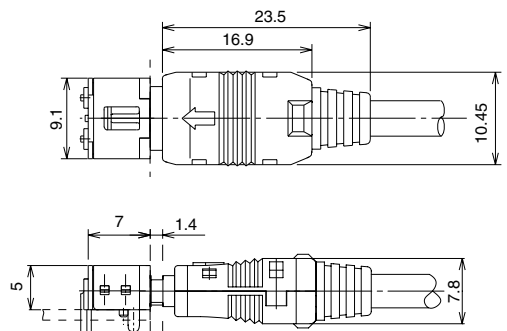

RP34L-5PA-3SC & RP34L-5R-3PD

This 3-contact plug is a field assembly type. Recommended cable diameter is 4mm dia.

■Product Specifications

Ratings	Current rating Voltage rating	5A 30V AC, 42A DC	Operating temp. range Storage temp. range	-25℃~+85℃ -10℃~+60℃
---------	----------------------------------	----------------------	--	------------------------

Item	Specification	Conditions
1.Contact resistance	30mΩ or max.	1A DC
2.Insulation resistance	1000mΩ min.	100V DC
3.Withstanding voltage	No flashover or insulation breakdown	150V AC/1 minute
4.Vibration	No electric disconnection of 10μs or more	10~55Hz, one-sided amplitude 0.75mm, 3 directions for 2hours, respectively
5.Temperature cycle	Insulation resistance:100mΩ min.	-55℃ for 30 min.→normal temp. for 10~15 min.→+85℃ for 30 min.→normal temp. for 10~15 min. 5 cycles
6.Salt spray	No corrosions	5% salt water solution, 48 hours
7.Durability	Contact resistance:60mΩ max.	5,000 mating / un-mating

■Material

Component		Material	Finish / Color	Remarks
2 pos.	Metal comp.	Phosphor bronze	Solder-plating	—
	Insulator	Nylon	Black	UL94HB
	Contacts	Brass	Palladium-plating	—
2 pos.	Cover	Vinyl chloride	Black	UL94V-0
	Insulator	Nylon	Black	UL94HB
	Contacts	Phosphor bronze		—
3 pos.	Metal comp.	Phosphor bronze	Solder-plating	—
	Insulator	PPS	Black	UL94V-0
	Contacts	Brass	Palladium-plating	—
3 pos.	Cover	Polycarbonate	Black	UL94V-0
		Vinyl chloride	Black	UL94V-0
	Insulator	PPS	Black	UL94V-0
	Contacts	Phosphor bronze	Palladium-plating	—

■Ordering information

RP34L - 5 PA - 2 SC (****)

① ② ③ ④ ⑤ ⑥

① Series name: RP34L	④ Number of contacts: 2, 3
② Shell: Shell.size, 5	
③ Type: Receptacle: R Assembled straight plug: P Assembled right angle plug: LP Cable ass'y, straight plug: PA	⑤ Type of contact: PD: through hole male contact SC: crimp female contact
	⑥ Cable length:(****) depends on each cable (mm).

■ Receptacles

● 2 pos.

RP34L-5R-2PD(71)

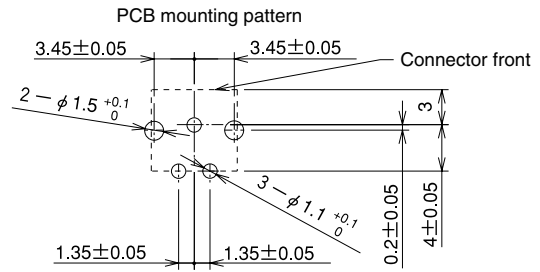
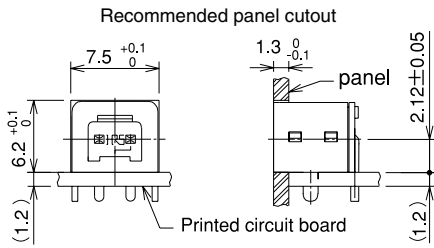
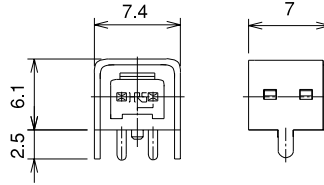

● 3 pos.

RP34L-5R-3PD(71)

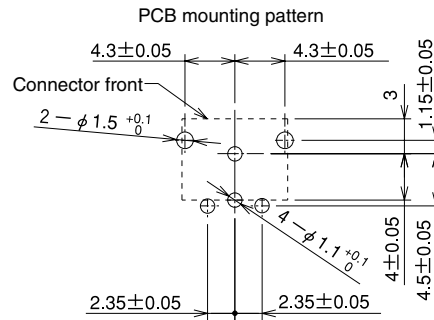
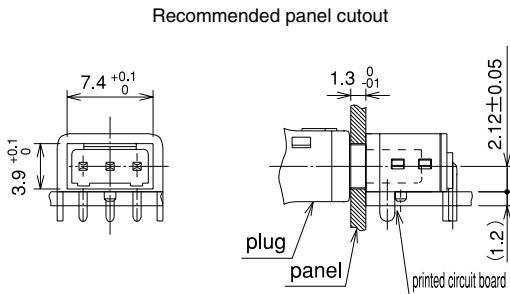
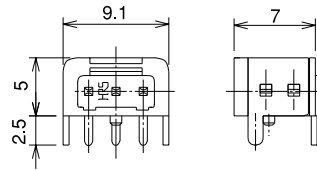

Part Number	CL No.	RoHS
RP34L-5R-2PD(71)	113-5154-6-71	YES
RP34L-5R-3PD(71)	113-5157-4-71	

■Crimp contact

■RP34L-SC1-212(01)

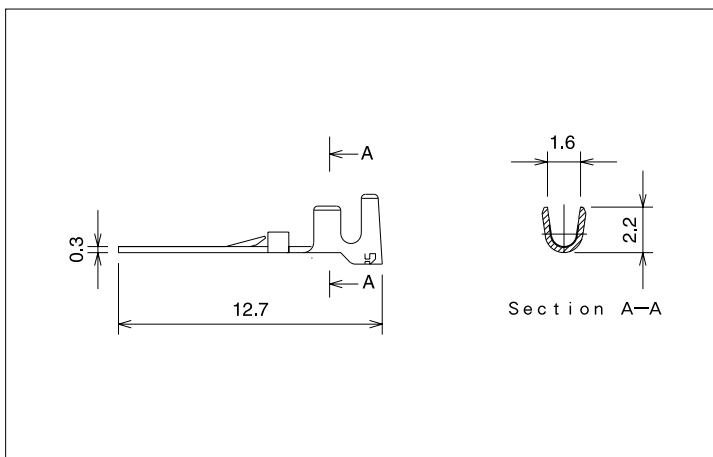
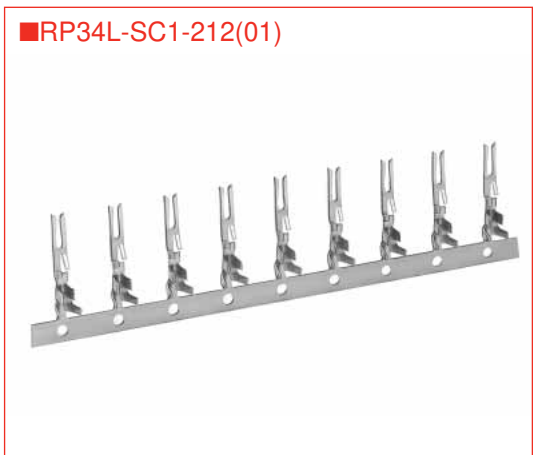

Part Number	CL No.	RoHS
RP34L-SC1-212(01)	113-5151-8-01	YES

■Applicable Tools

Type	Part Number	CL No.	Applicable contact	Applicable conductor
Manual crimping tool	HT-102/RP34L-SC1-212	—	RP34L-SC1-112(01)	AWG#18~#22
Crimper	Automatic	CM-105	—	—
	Crimper body	AP105-RP34L-SC1-212	RP34L-SC1-212(01)	AWG#18~#22
Cable crimping tool	RP34-TC-01	150-0074-1	—	φ4
Drawing tool	RP6-SC-TP	150-0039-0	—	—

■ Assembly Instructions(3-Position Plug)

● Straight Plug

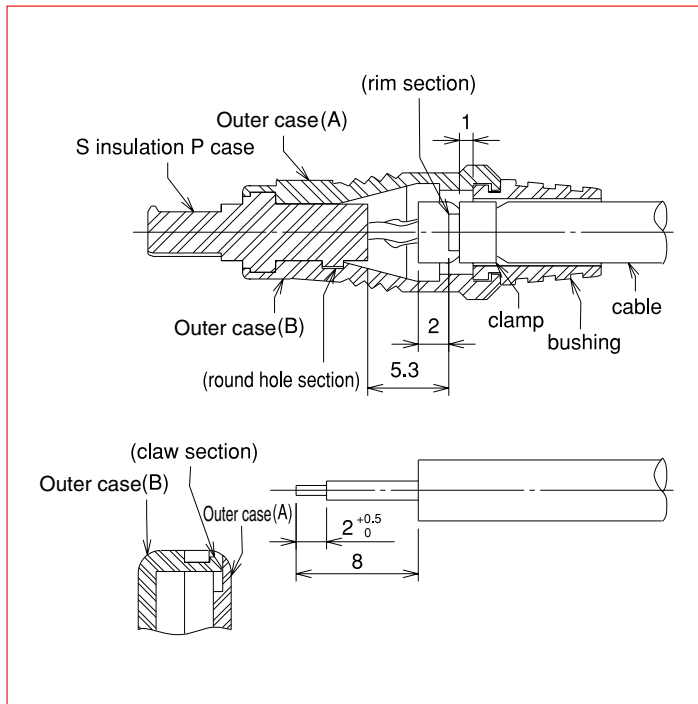

1. Slide the bushing over the cable.
2. Prepare the cable end and the conductors as shown.
3. Crimp the contacts to each conductor. Verify the crimp dimensions.
4. Insert each of the contacts into the insulator body. Verify that the contact is secure by slightly pulling on the conductor. Should the contacts require re-insertion, use the tool RP6-SC-TP to remove them (Inserted from the termination side).
5. Crimp the cable clamp over the cable at designated dimension (Tool number:RP34-TC-01).
6. Place the outer case on a flat surface, with inside facing up.
7. Carefully place the insulator body, clamp and the bushing into corresponding indents and cut-outs in the outer case. Verify correct location. (As shown on drawing)

Note A: When placing all components in the case, exercise caution as NOT to damage any of the protruding snap.

Note B: All components should fit easily, without use of any force.

8. Carefully align the other outer case over all components case. Do not force alignment.
9. Snap the case in place.

● Right Angle Plug

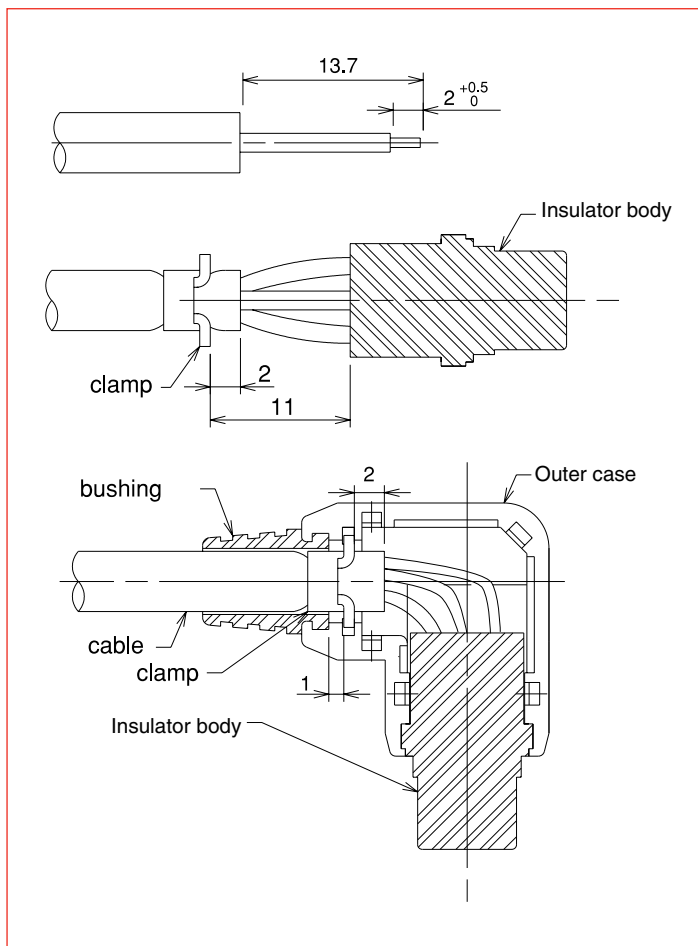

1. The right angle plug can also be assembled by using the same procedure as the straight plug.

■Precautions

1. Use the connector section with its panel held down so as not to have excessive load. For 2-contact type, hold the outer shell section of the receptacle, and for 3 contact type, the outer shell section of the plug.

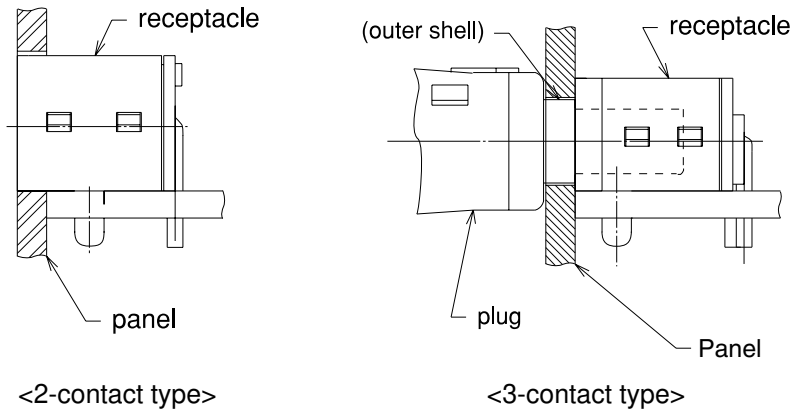

2. After connector assembly, cable must not be pulled over 30N in the arrow-indicated direction. Be careful not to add excessive tensile load because it will lead the damage of connectors.

