



Chipsmall Limited consists of a professional team with an average of over 10 year of expertise in the distribution of electronic components. Based in Hongkong, we have already established firm and mutual-benefit business relationships with customers from,Europe,America and south Asia,supplying obsolete and hard-to-find components to meet their specific needs.

With the principle of "Quality Parts,Customers Priority,Honest Operation,and Considerate Service",our business mainly focus on the distribution of electronic components. Line cards we deal with include Microchip,ALPS,ROHM,Xilinx,Pulse,ON,Everlight and Freescale. Main products comprise IC,Modules,Potentiometer,IC Socket,Relay,Connector.Our parts cover such applications as commercial,industrial, and automotives areas.

We are looking forward to setting up business relationship with you and hope to provide you with the best service and solution. Let us make a better world for our industry!



Contact us

Tel: +86-755-8981 8866 Fax: +86-755-8427 6832

Email & Skype: info@chipsmall.com Web: www.chipsmall.com

Address: A1208, Overseas Decoration Building, #122 Zhenhua RD., Futian, Shenzhen, China



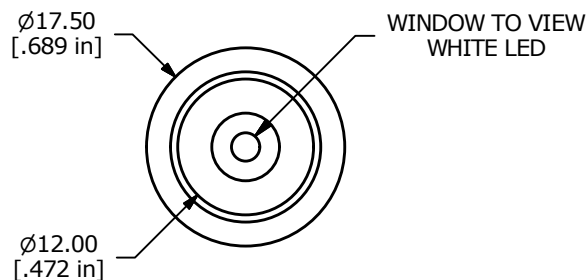
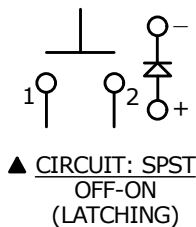
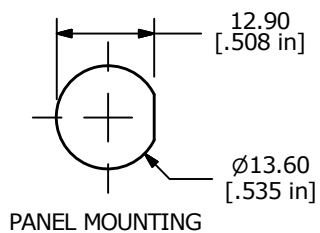

| LED PARAMETER | FORWARD CURRENT | FORWARD VOLTAGE @ 20mA | LUMINOUS INTENSITY |
|---------------|-----------------|------------------------|--------------------|
| UNITS | mA | V | mcd |
| WHITE | 20 | 2.8 - 3.3 | 200 |

NOTE:

1. ALL DIMENSIONS IN MM [INCH]
2. GENERAL TOLERANCE: X.X=±0.4
X.XX=±0.25
3. TERMINAL NUMBERS FOR REF ONLY
4. CIRCUIT: SPST OFF-ON (LATCHING)
5. CONTACT MATERIAL: Gold over SILVER
6. RATING: 100mA @ 24 VDC
7. ELECTRIC LIFE: 200,000 CYCLES AT FULL LOAD
8. CONTACT RESISTANCE: 100 milli-OHM max. (INITIAL)
9. INSULATION RESISTANCE: 1,000 MEGA-OHM min. @ 500VDC.
10. DIELECTRIC STRENGTH: 1,000 VAC rms.
- ▲ 11. OPERATING FORCE: 350 gf ±150 gf
12. OPERATING TEMPERATURE: -30°C TO +85°C.
13. CONTACT BOUNCE: 10ms MAX.
- ▲ 14. TRAVEL: 2.5mm ±0.25mm
15. PANEL THICKNESS RANGE: 1.5 - 4.0 mm.
16. ▲ DENOTES CRITICAL PARAMETER.
17. 2011/65/EU (ROHS) COMPLIANT
18. MAX MOUNTING TORQUE: 1.5 Nm APPLIED TO THE NUT
19. HARDWARE INCLUDED:
 1. T081101 LOCK WASHER (1)
 2. T081102 HEX NUT (1)
 3. T081103 O-RING (1)
20. SEAL RATING: IP67 AT THE FRONT PANEL

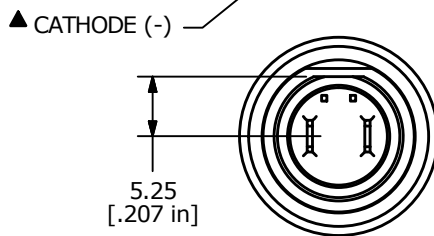
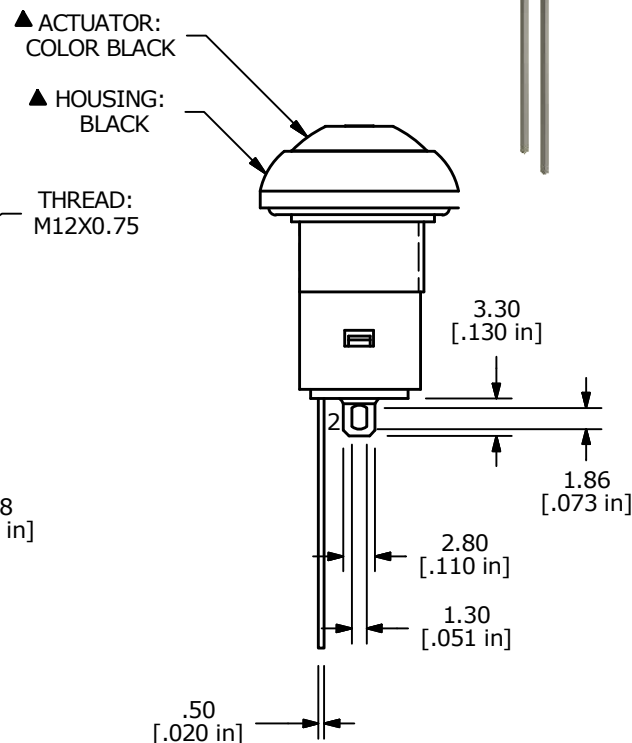
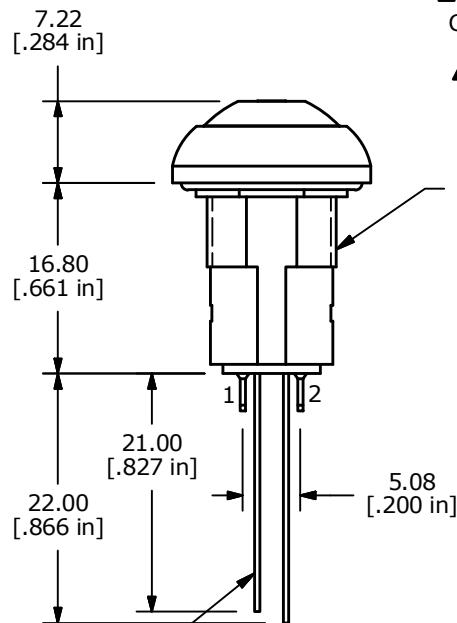

| | | | | |
|-----|--------|--------------------------------------|---------|-----|
| E | 22455 | UPDATED OPER. FORCE FROM 560 TO 350 | 8/17/16 | MJR |
| D | 21597 | CHANGE SEAL RATING FROM IP65 TO IP67 | 9/29/14 | EBP |
| REV | PCR NO | DESCRIPTION | DATE | BY |

| | | | | |
|-----------------------------|---------------|-------|--------------|-------|
| TITLE RP8200B2M1CEBLKBLKWHT | | | | |
| SCALE 3:2 | DATE 6/7/2010 | DR rc | DWG ST082007 | REV E |

THE INFORMATION CONTAINED IN THIS DOCUMENT IS PROPRIETARY TO E-SWITCH AND IS NOT TO BE COPIED OR TRANSFERRED