



Chipsmall Limited consists of a professional team with an average of over 10 year of expertise in the distribution of electronic components. Based in Hongkong, we have already established firm and mutual-benefit business relationships with customers from,Europe,America and south Asia,supplying obsolete and hard-to-find components to meet their specific needs.

With the principle of “Quality Parts,Customers Priority,Honest Operation,and Considerate Service”,our business mainly focus on the distribution of electronic components. Line cards we deal with include Microchip,ALPS,ROHM,Xilinx,Pulse,ON,Everlight and Freescale. Main products comprise IC,Modules,Potentiometer,IC Socket,Relay,Connector.Our parts cover such applications as commercial,industrial, and automotives areas.

We are looking forward to setting up business relationship with you and hope to provide you with the best service and solution. Let us make a better world for our industry!



Contact us

Tel: +86-755-8981 8866 Fax: +86-755-8427 6832

Email & Skype: info@chipsmall.com Web: www.chipsmall.com

Address: A1208, Overseas Decoration Building, #122 Zhenhua RD., Futian, Shenzhen, China



Marking Layout

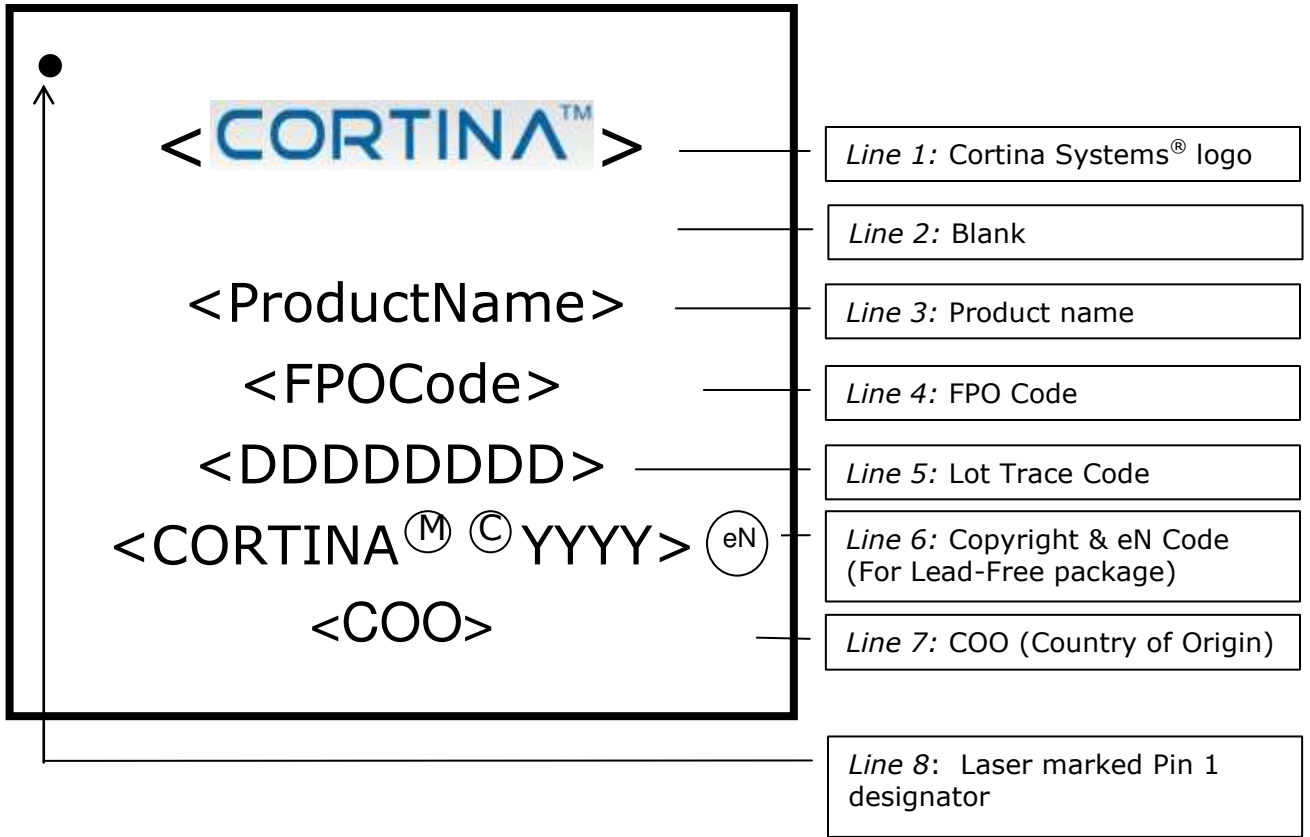

Photograph of Marked Device



Marking Layout Description

Line #	Content	Fixed or Dynamic	Alignment	Font
1	Cortina Systems® logo	Fixed	Centered	NA
2	Reserved for Customer / Marketing	NA	NA	NA
3	Product Name	Fixed	Centered	Arial
4	FPO Code	Dynamic	Centered	Arial
5	Lot Trace Code	Dynamic	Centered	Arial
6	Copyright	Fixed	Left	Arial
7	COO (Country of Origin) & en (e1) as required	Fixed	Centered	Arial
7	Pin 1 Location marked by designator	Fixed	Left	NA

Product Naming Decoder

- RP** RP Stands for RoHS compliance level and Package Designator (FCBGA)
- RPCS** CS stands for the Product Prefix
- RPCS1999** Product number is a 3-5 digit alphanumeric
- RPCS1999C** Temperature indicator (commercial, extended)
- RPCS1999C A0** Product revision, xn=2 Alphanumeric character

* Device name may be truncated or alphanumeric characters left out intentionally on actual part marking due to lack of space and the need for legibility.

Product Order Number

- RPCS1999C.A0-998866** The complete Cortina Systems ordering code includes this numeric 6 digit number. The MM# identifies the packing media (Tube, Tray, and Tape & Reel) from identical devices. Product revision changes are assigned new MM#. The MM# is not marked on the physical component but it appears on MBB, box and packing labels, packing slips, shipping documents, and invoices.

FPO Number & Date Code

- BYWWT00A** Fixed header character for test subcontractor / location
- BYWWT00A** Last digit of manufacturing year, Ex: Year 2009 = 9
- BYWWT00A** Cortina workweek, first week of January = 01
- BYWWT00A** Assembly house and location code
- BYWWT00A** Sequential number that resets when WW is incremented: Refers to both sub-lots and wafer lots.

- Lot Trace Code Cortina Internal use.

Author	Revision Content	Rev No.	Date
SY Fong	Initial Release	1.0	18 February 2009

INFORMATION IN THIS DOCUMENT IS PROVIDED IN CONNECTION WITH CORTINA SYSTEMS® PRODUCTS. NO LICENSE, EXPRESS OR IMPLIED, BY ESTOPPEL OR OTHERWISE, TO ANY INTELLECTUAL PROPERTY RIGHTS IS GRANTED BY THIS DOCUMENT. EXCEPT AS PROVIDED IN CORTINA'S TERMS AND CONDITIONS OF SALE OF SUCH PRODUCTS, CORTINA ASSUMES NO LIABILITY WHATSOEVER, AND CORTINA DISCLAIMS ANY EXPRESS OR IMPLIED WARRANTY RELATING TO THE SALE AND/OR USE OF CORTINA PRODUCTS, INCLUDING LIABILITY OR WARRANTIES RELATING TO FITNESS FOR A PARTICULAR PURPOSE, MERCHANTABILITY OR INFRINGEMENT OF ANY PATENT, COPYRIGHT OR OTHER INTELLECTUAL PROPERTY RIGHT.

Cortina products are not intended for use in medical, life saving, life sustaining, critical control or safety systems, or in nuclear facility applications.

CORTINA SYSTEMS®, CORTINA™, and the Cortina Earth Logo are trademarks or registered trademarks of Cortina Systems, Inc. or its subsidiaries in the US and other countries. Any other product and company names are the trademarks of their respective owners.

Copyright © 2009 Cortina Systems, Inc. All rights reserved.