



Chipsmall Limited consists of a professional team with an average of over 10 year of expertise in the distribution of electronic components. Based in Hongkong, we have already established firm and mutual-benefit business relationships with customers from,Europe,America and south Asia,supplying obsolete and hard-to-find components to meet their specific needs.

With the principle of “Quality Parts,Customers Priority,Honest Operation,and Considerate Service”,our business mainly focus on the distribution of electronic components. Line cards we deal with include Microchip,ALPS,ROHM,Xilinx,Pulse,ON,Everlight and Freescale. Main products comprise IC,Modules,Potentiometer,IC Socket,Relay,Connector.Our parts cover such applications as commercial,industrial, and automotives areas.

We are looking forward to setting up business relationship with you and hope to provide you with the best service and solution. Let us make a better world for our industry!



## Contact us

Tel: +86-755-8981 8866 Fax: +86-755-8427 6832

Email & Skype: info@chipsmall.com Web: www.chipsmall.com

Address: A1208, Overseas Decoration Building, #122 Zhenhua RD., Futian, Shenzhen, China



REV	ECN	APP'D
-	5689	

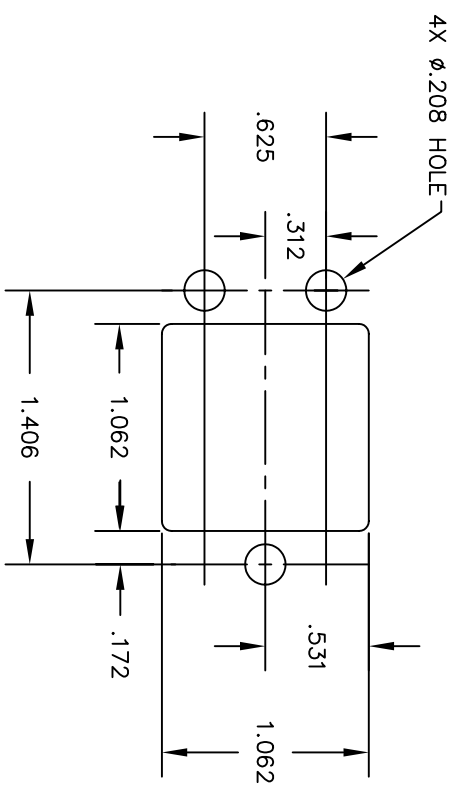

RECOMMENDED MOUNTING  
PANEL HOLE

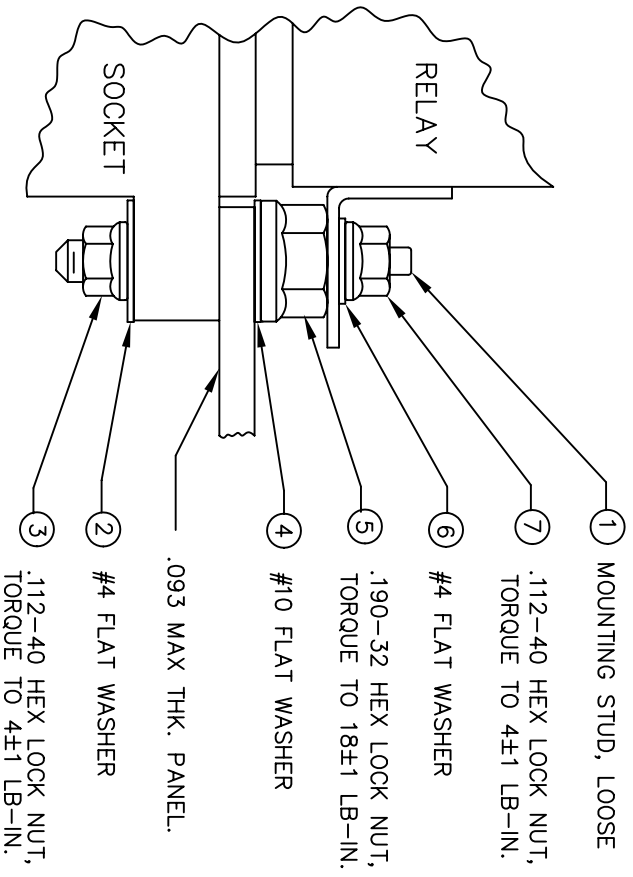

MOUNTING HARDWARE  
INSTALLATION SEQUENCE BY ITEM NUMBER  
TYP 4 PLACES

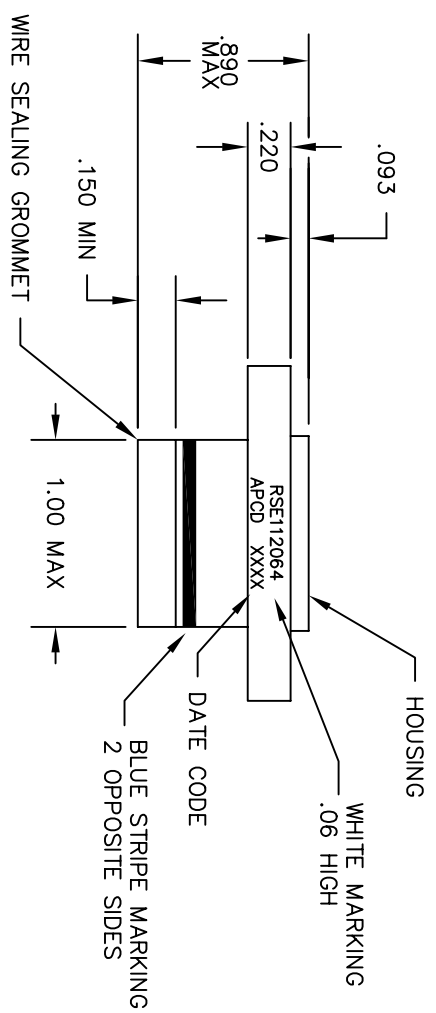
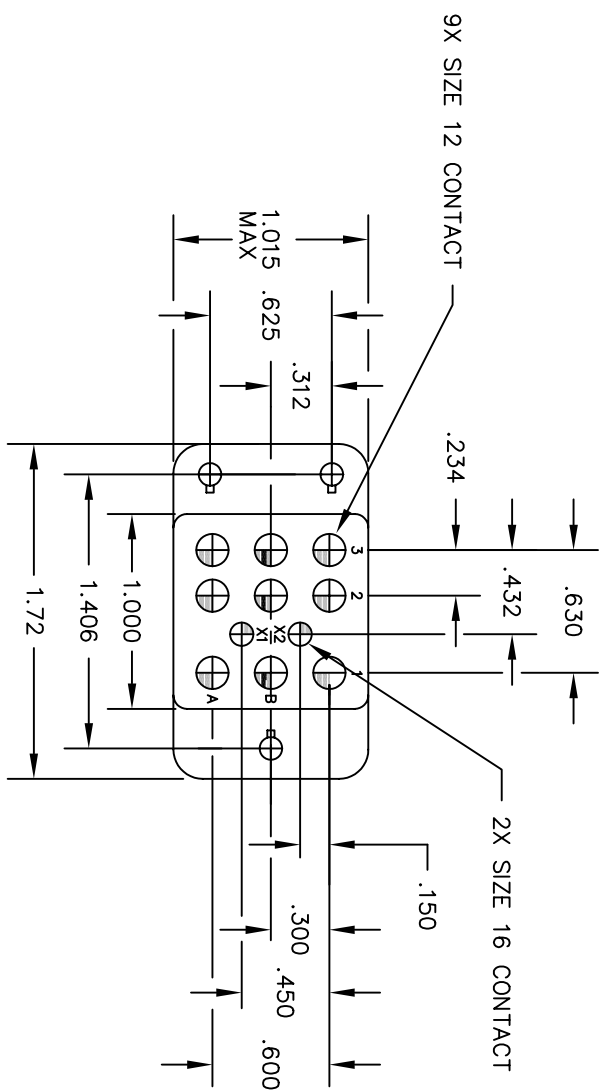

- NOTES:
1. CONFORMS TO PERFORMANCE REQUIREMENTS OF MIL-PRF-12883
  2. MATERIALS:
    - A. HOUSING - POLYETHERIMIDE, COLOR: BLUE-GREEN.
    - B. GROMMET - SILICONE ELASTOMER, COLOR: RED.
  3. SOCKET CONTACTS CONFORM TO PERFORMANCE REQUIREMENTS OF MIL-C-39029, GOLD OVER NICKEL PLATE.
  4. OPERATING TEMPERATURE: +125°C/-65°C CONTINUOUS.
  5. CONTACT INSTALLATION TOOLS:
    - #12 CONTACT CRIMP TOOL: M22520/1-01
    - POSITIONER: M22520/1-02
    - INSERTION/REMOVAL: M81969/14-04
    - #16 CONTACT CRIMP TOOL: M22520/1-01
    - POSITIONER: M22520/1-02
    - INSERTION/REMOVAL: M81969/14-03.

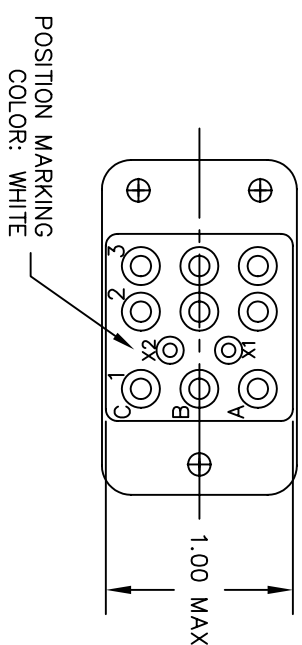

DIMENSIONS	TOLERANCES	PROJECTION
ANSI Y14.5M UNITS: INCHES ACAD FILE	.XX ±.01 .XXX ±.005 ANGLES ±2°	

**Amphenol Pcd**  
SPECIFICATION DRAWING  
ENGR R. SWAINE 9/20/05  
CHKD APPD

ORIGINAL  
THIS DOCUMENT CONTAINS  
PROPRIETARY INFORMATION WHICH  
IS THE CONFIDENTIAL PROPERTY  
OF AMPHENOL PCD INC. PEABODY, MA

TITLE	PART NO.	CONTACTS SUPPLIED
RELAY SOCKET SIZE 12 & 16 LOOSE STUD	SZ 12/12 CNS128900	SZ 16/16 CNS126900
	RSE112064	-

SIZE	DWG NO.	REV
B	RSE112064	-
CODE: 58982	1:1	SHEET 1 OF 1