



Chipsmall Limited consists of a professional team with an average of over 10 year of expertise in the distribution of electronic components. Based in Hongkong, we have already established firm and mutual-benefit business relationships with customers from,Europe,America and south Asia,supplying obsolete and hard-to-find components to meet their specific needs.

With the principle of “Quality Parts,Customers Priority,Honest Operation,and Considerate Service”,our business mainly focus on the distribution of electronic components. Line cards we deal with include Microchip,ALPS,ROHM,Xilinx,Pulse,ON,Everlight and Freescale. Main products comprise IC,Modules,Potentiometer,IC Socket,Relay,Connector.Our parts cover such applications as commercial,industrial, and automotives areas.

We are looking forward to setting up business relationship with you and hope to provide you with the best service and solution. Let us make a better world for our industry!



Contact us

Tel: +86-755-8981 8866 Fax: +86-755-8427 6832

Email & Skype: info@chipsmall.com Web: www.chipsmall.com

Address: A1208, Overseas Decoration Building, #122 Zhenhua RD., Futian, Shenzhen, China



Power Management IC with Single Cell Li-Battery Switching Charger Integrated Power Path Controller

General Description

The RT5036 is a highly integrated smart power management IC which includes: switch-mode single cell Li-Ion/Li-Polymer battery charger, LDO, synchronize Buck regulator, Load Switch, and RTC-OSC for portable applications. The RT5036 also features USB On-The-Go (OTG) support.

The RT5036 optimizes the charging task by using a control algorithm to vary the charge rate via different modes, including pre-charge mode, fast charge mode, and constant voltage mode. The key charge parameters can be programmed via the I²C interface. The RT5036 resumes the charge cycle whenever the battery voltage falls below an internal threshold and automatically enters sleep mode when the input power supply is removed.

Four integrated Synchronize Buck Regulators are designed to provide MAX 1.6/1.6/1.2/1.2A application with high efficiency.

Four integrated LDOs are designed to provide MAX 0.35/0.35/0.35/0.35A application.

Two Load Switches are integrated with load Ron. And a Real Time Clock (RTC) includes time counter and a 32768Hz oscillator for portable applications.

The RT5036 also provides rich protection functions : Over Current Protection, Under Voltage Protection, Over Voltage Protection, Over Temperature Protection, and Over Load Protection.

Ordering Information

RT5036□□

- Package Type
QW : WQFN-40L 5x5 (W-Type)
- Lead Plating System
G : Green (Halogen Free and Pb Free)

Note :

Richtek products are :

- ▶ RoHS compliant and compatible with the current requirements of IPC/JEDEC J-STD-020.
- ▶ Suitable for use in SnPb or Pb-free soldering processes.

Features

- **Battery Charger**
 - ▶ High Accuracy Voltage/Current Regulation
 - ▶ Average Input Current Regulation(AICR) : 0.1/0.5/0.7/0.9/1/1.5/2A
 - ▶ Minimum Input Voltage Regulation(MIVR) : 4.2V to 4.8V
 - ▶ Charge Voltage Regulation: 3.65V to 4.4V
 - ▶ Charge Current Regulation: 0.5A to 2A
 - ▶ Synchronous 0.75/1.5MHz Fixed Frequency PWM Controller With Up To 95% Duty Cycle
 - ▶ Reverse Leakage Protection To Prevent Battery Drainage
 - ▶ Thermal Regulation
 - ▶ IRQ Output For Communication With I²C
 - ▶ Battery Temperature Detection
 - ▶ Reverse Boost to Support OTG 1A
- **4 LDOs**
 - ▶ MAX Output Current 0.35/0.35/0.35/0.35A
 - ▶ I²C Programmable Output Level
- **4 LV Buck Regulators**
 - ▶ MAX Output Current 1.6/1.6/1.2/1.2A
 - ▶ I²C Programmable Output Level
 - ▶ No Schottky Barrier Diode Required
 - ▶ 1.5M/3MHz Fixed Frequency Operation
 - ▶ Auto Discharge Function
- **RTC Timer and Oscillator**
- **2 Load Switches**

Applications

- Cellular Telephones
- Personal Information Appliances
- Tablet PC, Power Bank
- Portable Instruments

Pin Configurations

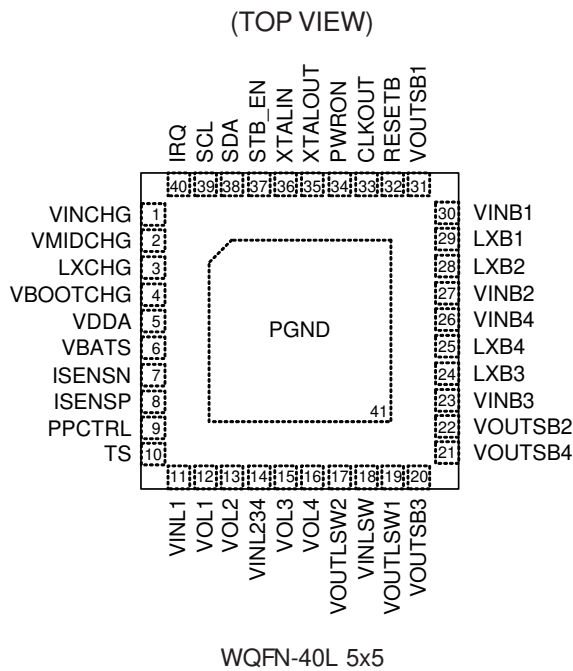

Marking Information

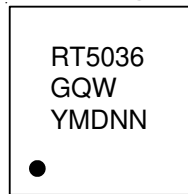

RT5036GQW : Product Number

YMDNN : Date Code

Functional Pin Description

Pin No.	Pin Name	Pin Function
1	VINCHG	Charger Input Voltage For Adaptor/USB Power Source.
2	VMIDCHG	Connection Point Between Reverse Blocking and High Side MOSFET.
3	LXCHG	Internal Switch Node To Output Inductor Connection of Switching Charger
4	VBOOTCHG	Bootstrap Power Node For Switching Charger
5	VDDA	Internal Power For Analog Blocks, Put 1 μ F To GND.
6	VBATS	Battery Voltage Regulation Node for Charger.
7	ISENSN	Charging Current Sensing Negative Node.
8	ISENSP	Charging Current Sensing Positive Node
9	PPCTRL	External Power Path Control. Used to control external power P-MOSFET to achieve power path operation.
10	TS	Battery Temperature Detection.
11	VINL1	Input Power for LDO1.
12	VOL1	Output Voltage Regulation Node for LDO1.
14	VINL234	Input Power for LDO2, LDO3, LDO 4.
13	VOL2	Output Voltage Regulation Node for LDO2.
15	VOL3	Output Voltage Regulation Node for LDO3.
16	VOL4	Output Voltage Regulation Node for LDO4.
17	VOUTLSW2	Output Pin for Load Switch 2.
18	VINLSW	Input Pin for Load Switches GOOD.

Pin No.	Pin Name	Pin Function
19	VOUTLSW1	Output Pin for Load Switch 1.
20	VOUTSB3	Output Voltage Regulation Node for Buck3.
21	VOUTSB4	Output Voltage Regulation Node for Buck4.
22	VOUTSB2	Output Voltage Regulation Node for Buck2.
23	VINB3	Input Power for Buck3.
24	LXB3	Internal Switch Node to Output Inductor Connection for Buck3.
25	LXB4	Internal Switch Node to Output Inductor Connection for Buck4.
26	VINB4	Input Power for Buck4.
27	VINB2	Input Power for Buck2.
28	LXB2	Internal Switch Node to Output Inductor Connection for Buck2.
29	LXB1	Internal Switch Node to Output Inductor Connection for Buck1.
30	VINB1	Input Power for Buck1.
31	VOUTSB1	Output Voltage Regulation Node for Buck1.
32	RESETB	Power-On Reset Output and Reset Key Input. Open drain, Connect A Pull-Up Resister. The pin is high impedance after RT5036 booting completely, otherwise, the pin is short to GND. Low pulse to triggers soft reset event.
33	CLKOUT	RTC 32768Hz Clock Output. Open drain.
34	PWRON	Power On Key Input. Low pulse to triggers power-on event.
35	XTALOUT	Crystal Output. This pin's parasitic capacitance should be kept as low as possible. Noise interference should also be avoided.
36	XTALIN	Crystal Input. This pin's parasitic capacitance should be kept as low as possible. Noise interference should also be avoided.
37	STB_EN	Standby Mode control pin. From low to high will trigger standby mode and from high to low will leave standby mode.
38	SDA	Data Input For I ² C. Open Drain, Connect A Pull-Up Resister.
39	SCL	Clock Input For I ² C. Open Drain, Connect A Pull-Up Resister
40	IRQ	IRQ Output Node. Open drain.
41 (Exposed Pad)	PGND	The exposed pad must be soldered to a large PCB and connected to PGND for maximum thermal dissipation and current flow.

Function Block Diagram

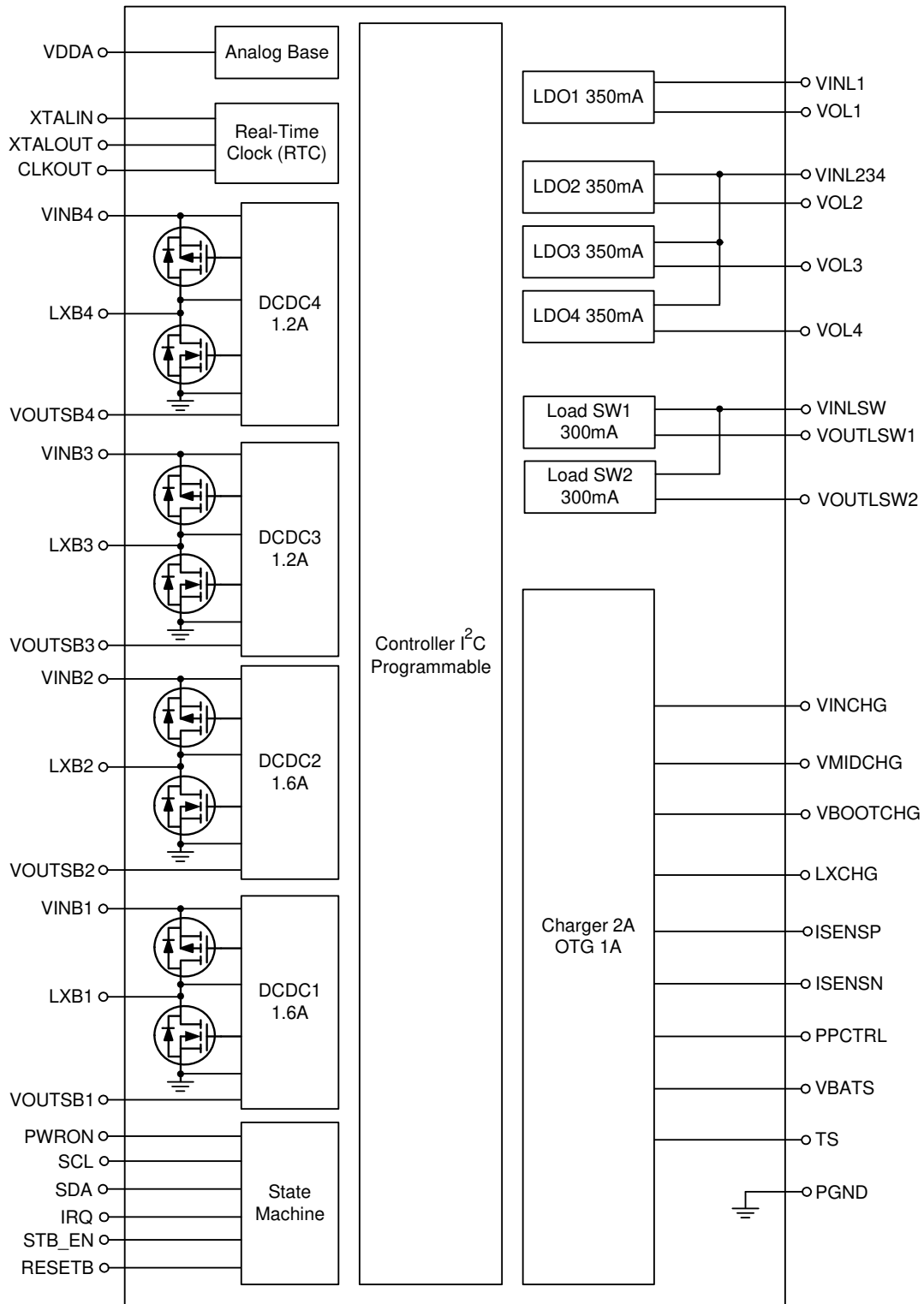

Stand-By and Wake-Up Flow Chart

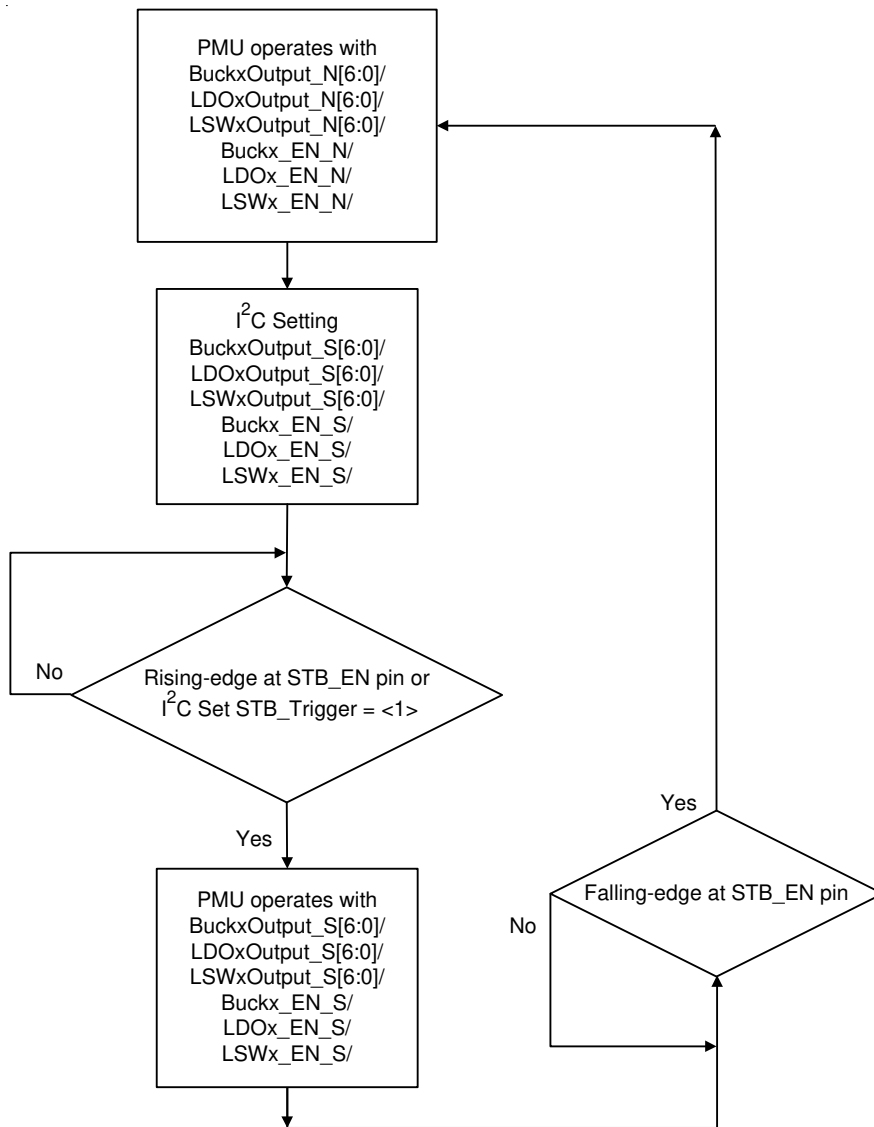

Protection Flow Chart

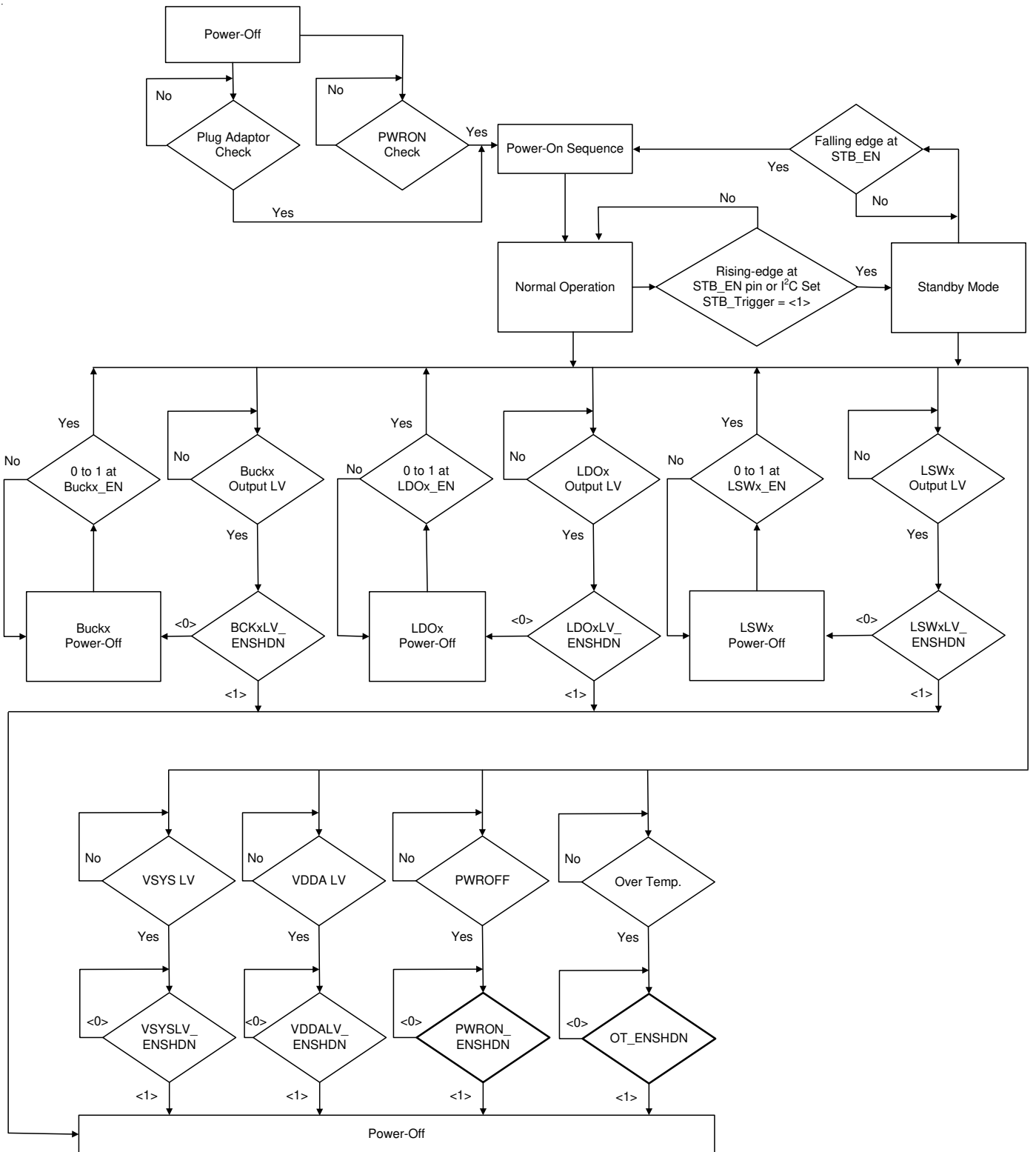

Charger Flow Chart

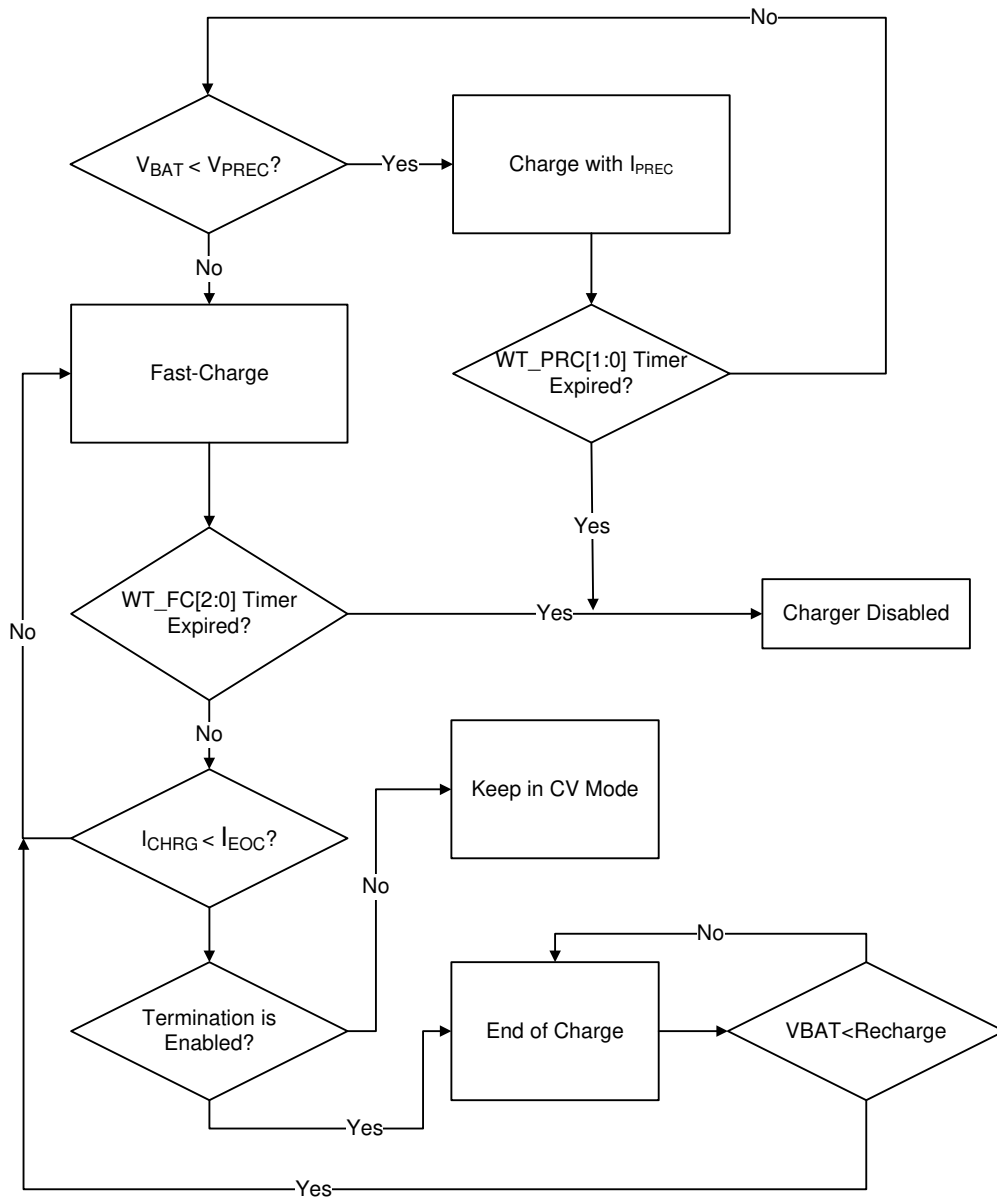

Absolute Maximum Ratings (Note 1)

- Supply Input Voltage ----- -0.3V to 10V
- VMIDCHG, VBOOTCHG ----- -0.3V to 10V
- LXCHG ----- -0.3V to 6V
- VMIDCHG – VINCHG, VBOOTCHG – LXCHG ----- -0.3V to 6V
- Others ----- -0.3V to 6V
- Power Dissipation, P_D @ T_A = 25°C
 - WQFN-40L 5x5 ----- 3.63W
- Package Thermal Resistance (Note 2)
 - WQFN-40L 5x5, θ_{JA} ----- 27.5°C/W
 - WQFN-40L 5x5, θ_{JC} ----- 6°C/W
- Junction Temperature ----- 150°C
- Lead Temperature (Soldering, 10 sec.) ----- 260°C
- Storage Temperature Range ----- -65°C to 150°C
- ESD Susceptibility (Note 3)
 - HBM (Human Body Model) ----- 2kV
 - MM (Machine Model) ----- 200V

Recommended Operating Conditions (Note 4)

- Supply Input Voltage ----- 4.3V to 5.5V
- Junction Temperature Range ----- -40°C to 125°C
- Ambient Temperature Range ----- -40°C to 85°C

Electrical Characteristics

(VINCHG = 5V, VISENSN = 4.2V, L = 1μH, C_{VINCHG} = 4.7μF, C_{VBATS} = 4.7μF, T_A = 25°C, unless otherwise specified)

Parameter	Symbol	Test Conditions	Min	Typ	Max	Unit
Input Power Source						
VINCHG Operation Range			4.3	--	5.5	V
VINCHG Supply Current		Charger is switching, ICHG = 0, Buck loading = 0, LDOs loading = 0	--	10	--	mA
VINCHG Supply Current		Charger is not switching, ICHG = 0, Bucks loading = 0, LDOs loading = 0	--	--	5	mA
Leakage Current from Battery		VISENSN = 3.8V, VINCHG = 0V, Charger, Bucks and LDOs and LSWs are OFF. SCL = SDA = 0V.	--	--	50	μA
Protection						
VINCHG OVP Threshold Voltage			5.6	5.75	5.9	V
VINCHG OVP Hysteresis			--	100	--	mV
ISENSN OVP			110	117	124	%
ISENSN OVP Hysteresis			--	10	--	%
Over Temperature Protection		(Note 4)	--	165	--	°C

Parameter	Symbol	Test Conditions	Min	Typ	Max	Unit
OTP Hysteresis			--	10	--	°C
Thermal Regulation Threshold		Charge Current Begins To Reduce (Note 4)	--	120	--	°C
Input Power Source Detection						
Poor Source Detect Threshold		Bad Voltage Source Detection	3.6	3.8	4	V
Poor Source Detect Deglitch			--	30	--	ms
Poor Source Detect Hysteresis		VINCHG Rising	100	--	200	mV
Current Sink to GND		During Poor Source Detection	--	45	--	mA
Detection Interval		Input Power Source Detection	--	2	--	s
Sleep Mode Comparator						
Sleep-Mode Entry Threshold VINCHG – ISENSN	V _{SLP}	3V < ISENSN < V _{BATREG} , VINCHG Falling	0	0.04	0.1	V
Sleep-Mode Exit Hysteresis VINCHG - ISENSN	V _{SLPEXIT}	3V < ISENSN < V _{BATREG} , VINCHG Rising	40	120	200	mV
Sleep-Mode Deglitch Time	t _{SLP}	VINCHG Rising Above V _{SLP} + V _{SLPEXIT}	--	128	--	ms
Under Voltage Lockout (UVLO) Threshold for VINCHG						
Charger Active Threshold Voltage		VINCHG Rising,	3.05	3.3	3.45	V
Charger Active Hysteresis		VINCHG Falling	--	150	--	mV
Minimum Input Voltage Regulation (MIVR)						
Minimum Input Voltage Regulation	V _{MIVR}	I ² C per 0.1V	4.2	--	4.8	V
V _{MIVR} Accuracy			-5	--	5	%
Average Input Current Regulation (AICR) Accuracy	I _{AICR}	I _{AICR} = 100mA	80	90	100	mA
		I _{AICR} = 500mA	400	450	500	
		I _{AICR} = 1000mA	800	900	1000	
VDDA Regulator						
VDDA Voltage		V _{VINCHG} > 4.5V	--	4.5	--	V
		V _{VINCHG} < V _{ISENSN}	--	V _{ISENSN}	--	V
VDDA UVLO		VDDA Falling	2.4	2.5	2.6	V
VDDA UVLO Hysteresis		VDDA Rising	--	0.2	--	
Battery Voltage Regulation						
Battery Voltage Regulation	V _{BATREG}	I ² C Programmable Per 25mV	3.65	--	4.4	V
V _{BATREG} Accuracy		0 to 85°C	-1	--	1	%

Parameter	Symbol	Test Conditions	Min	Typ	Max	Unit
Re-Charge Threshold	(V _{BATREG} – V _{REC})	V _{BATS} Falling, (V _{BATREG} – V _{REC}) = programmable	100	--	300	mV
Re-Charge Deglitch	t _{REC}		--	128	--	ms
Charging Current Regulation						
Output Charging Current	I _{CHG}	I ² C Per 0.1A, R _{SENSE} = 20mΩ	0.7	--	2	A
I _{CHG} Accuracy		R _{SENSE} = 20mΩ	-100	--	100	mA
Pre-Charge Threshold	V _{PREC}	I ² C Per 0.1V, rising threshold	2.3	--	3.8	V
V _{PREC} Accuracy			-5	--	5	%
Pre-Charge Current	I _{PREC}	I ² C Per 100mA, from V _{BATS} U100 mode : I _{PREC} will fix 50mA	150	--	450	mA
I _{PREC} Accuracy			-20	--	20	%
Charge Termination Detection						
End of Charge Current	I _{EOC}	I ² C per 50mA, R _{SENSE} = 20mΩ U100 mode : I _{EOC} will fix 50mA	150	--	600	mA
I _{EOC} Accuracy		R _{SENSE} = 20mΩ	-100	--	100	mA
Deglitch Time for EOC	t _{EOC}	I _{CHG} < I _{EOC} , V _{ISENSN} > V _{REC} I ² C 32/64/128/256us	32	--	256	μs
Charger Timer Protection						
FastCharge Timer		I ² C per 2 Hrs	4	--	16	Hrs
PreCharge Timer		I ² C 0.5/1/2/4 Hrs	0.5	--	4	Hrs
Battery Detection Current	I _{BATDET}	As RNTC is disable, after EOC Done	--	0.5	--	mA
Battery Detection Time	t _{BATDET}	As RNTC is disable, after EOC Done	--	256	--	ms
NTC Monitor						
HOT Threshold	V _{VTS_HOT}	VTS falling, the ratio of VOL1, VINCHG > V _{IN(MIN)}	--	28	--	%VOL1
WARM Threshold	V _{VTS_WARM}	VTS falling, the ratio of VOL1, VINCHG > V _{IN(MIN)}	--	34	--	%VOL1
COOL Threshold	V _{VTS_COOL}	VTS rising, the ratio of VOL1, VINCHG > V _{IN(MIN)}	--	64	--	%VOL1
COLD Threshold	V _{VTS_COLD}	VTS rising, the ratio of VOL1, VINCHG > V _{IN(MIN)}	--	74	--	%VOL1
Accuracy of VTS			-2	--	2	%VOL1
Low Temperature Hysteresis	ΔV _{VTS}		--	1	--	%VPTS
Disable Threshold	V _{VTS_OFF}	TS function disable	--	--	5	%VPTS
Battery Absent Detection	V _{BAT_ABS}	VTS rising, the ratio of VPTS, VINCHG > V _{IN(MIN)}	--	90	--	%VPTS

Parameter	Symbol	Test Conditions	Min	Typ	Max	Unit
PWM Switching Charger						
Reverse Block On-Resistance	RREV	From VINCHG to VMIDCHG, as I _{AICR} disable or I _{AICR} = 2A	--	90	--	mΩ
High-Side On-Resistance	R _{HS}	From VMIDCHG to LXCHG	--	200	--	mΩ
Low-Side On-Resistance	R _{LS}	From CHGLX to PGND	--	90	--	mΩ
Charging Efficiency		V _{VINCHG} = 5V, V _{ISENSN} = 4V, and I _{CHG} = 1.5A,	--	85	--	%
Oscillator Frequency	f _{OSC}	I ² C for 0.75/1.5 MHz	--	1.5	--	MHz
Frequency Accuracy			-10	--	10	%
Maximum Duty Cycle		At Minimum Voltage Input	--	95	--	%
Minimum Duty Cycle			0	--	--	%
Peak OCP as Charger Mode			2.4	3	3.6	A
Reverse Boost Mode Operation						
Output Voltage Level		To VMIDCHG, I ² C per 25mV VMIDCHG setting ≥ V _{VBATS} + 0.4	3.625	--	5.2	V
Output Voltage Accuracy			-3	--	3	%
Efficiency		VMIDCHG = 5V, V _{ISENSN} = 4V, and Loading = 1A,	--	85	--	%
MAX Output Current for VINCHG		As V _{ISENSN} > 3.5V	1	--	--	A
Peak Over Current Protection			2.4	3.0	3.6	A
VMIDCHG OVP as Reverse Boost			--	5.5	--	V
VMIDCHG OVP Hysteresis			--	200	--	mV
Minimum Battery Voltage for Boost.	V _{BATMIN}	As Boost Start-Up. I ² C programmable Per 0.1V	2.9	--	3.6	V
I²C Characteristics						
Output Low Voltage	V _{OL}	I _{DS} = 10mA	--	--	0.4	V
SCL /SDA Input Threshold Voltage	V _{IH}	Logic High Threshold	1.4	--	--	V
	V _{IL}	Logic Low Threshold	--	--	0.4	V
SCL Clock			--	--	400	kHz

Parameter	Symbol	Test Conditions	Min	Typ	Max	Unit
Control I/O Pin						
Output Low Voltage (IRQ, RESETB)	V _{OL}	I _{DS} = 10mA	--	--	0.4	V
Logic Input Threshold Voltage (PWRON)	V _{IH}	Logic High Threshold	1.4	--	--	V
	V _{IL}	Logic Low Threshold	--	--	0.4	V
LDO1 to LDO4, LSW1, LSW2						
VINL1, VINL234 Input Voltage Range	V _{VINL1,234}		2.7	--	5.5	V
LDO1 to LDO4 Adjustable Output Range		I ² C per 25mV	0.8	--	3.3	V
PSRR		V _{VINL1, 234} = 4V, F = 1kHz, C _{VOL1 to 4} = 1μF	--	60	--	dB
LDO1 to LDO4 MAX Current			350	--	--	mA
Output Current Limit for LDO1 to LDO4			500	--	--	mA
Drop Out Voltage		V _{VINL1, 234} = 3V, I _{OUT} = 150mA	--	--	150	mV
Internal Off Discharge			--	1	--	kΩ
VINLSW1, VINLSW2			2.7	--	5.5	V
LSW Drop Out Voltage		V _{VINLSW1, 2} = 3.3V, I _{OUT} = 500mA	--	0.2	--	V
Output Current Limit for LSW1, LSW2			600	--	--	mA
Synchronize Buck Regulator1 to Buck Regulator4						
VINB1 to VINB4 Input Voltage Range	V _{BUCKVIN}		2.7	--	5.5	V
Quiescent Current from VINB1 to VINB4		Loading = 0mA, no switch, Each one	--	25	40	μA
Shutdown Current from VINB1 to VINB4		Each one	--	0.1	1	μA
Buck1 to Buck4 Adjustable Output Range	V _{VOUTSB1 to 4}	I ² C per 25mV	0.8	--	3.3	V
Output Voltage Accuracy		V _{VINB1 to 4} = 2.7V to 5.5V, V _{OUT} > 1V	-3	--	3	%
Output Voltage Accuracy		V _{VINB1 to 4} = 2.7V to 5.5V, V _{OUT} ≤ 1V	-30	--	30	mV
High-Side On-Resistance		V _{VINB1 to 4} = 3.6V	--	0.20	--	Ω
Low -Side On-Resistance		V _{VINB1 to 4} = 3.6V	--	0.20	--	Ω
Buck 1, 2 Output Current capability		DC	1.6	--	--	A
Buck 1, 2 Output Current capability		Peak	2	--	--	A

Parameter	Symbol	Test Conditions	Min	Typ	Max	Unit
Output Voltage Accuracy		$V_{VINL1\ to\ 4} = 2.7V\ to\ 5.5V,$ $V_{OUT} > 1V$	-3		3	%
Output Voltage Accuracy		$V_{VINL1\ to\ 4} = 2.7V\ to\ 5.5V,$ $V_{OUT} \leq 1V$	-30		30	mV
Buck 3, 4 Output Current capability		DC	1.2	--	--	A
Buck 3, 4 Output Current capability		Peak	1.5	--	--	A
Oscillator Frequency		$V_{VINB1\ to\ 4} = 3.6V,$ Loading = 200mA	--	1.5	--	MHz
Maximum Duty Cycle			100	--	--	%
Soft-Start Time	T_{SS}		--	150	--	μs
Discharge Time		C_{OUT} of Buck = 10 μF , (Note 5)	--	--	10	ms
Line Regulation				0.1	--	%/V
RTC						
RTC Operation Voltage			2.4	--	4.5	V
RTC Quiescent Current		RTCPWR > UVLO Threshold, XIN = XOUT = 14pF	--	--	3	μA
RTC Clock			--	32.768	--	kHz
RTC Clock Accuracy		RTC Operation Voltage = 1.6V to 3.3V	-10	--	10	ppm
RTC Clock Output High		Pin C32K Source Out 0.1mA	V_{DDA} -0.3	--	--	V
RTC Clock Output Low		Pin C32K Sink 0.1mA	--	--	0.3	V
RTC OSC Startup Time			--	0.5	1	s

Note 1. Stresses beyond those listed “Absolute Maximum Ratings” may cause permanent damage to the device. These are stress ratings only, and functional operation of the device at these or any other conditions beyond those indicated in the operational sections of the specifications is not implied. Exposure to absolute maximum rating conditions may affect device reliability.

Note 2. θ_{JA} is measured at $T_A = 25^\circ C$ on a high effective thermal conductivity four-layer test board per JEDEC 51-7. θ_{JC} is measured at the exposed pad of the package.

Note 3. Devices are ESD sensitive. Handling precaution is recommended.

Note 4. The device is not guaranteed to function outside its operating conditions.

Note 5. Guarantee By Design.

Typical Application Circuit

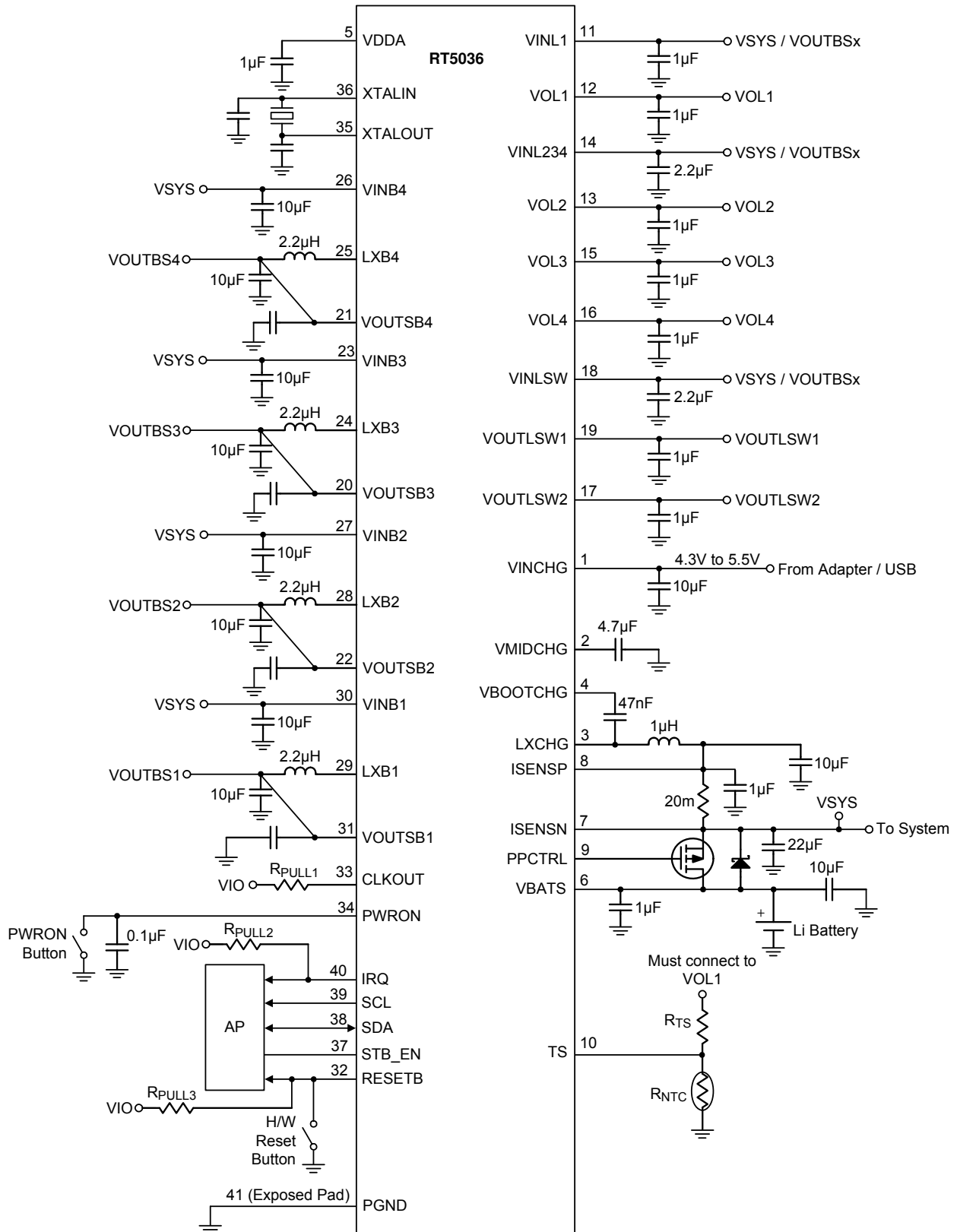

Timing Diagram

PMIC - POWER On/Off DIAGRAM

Timing Based On/Off Sequence

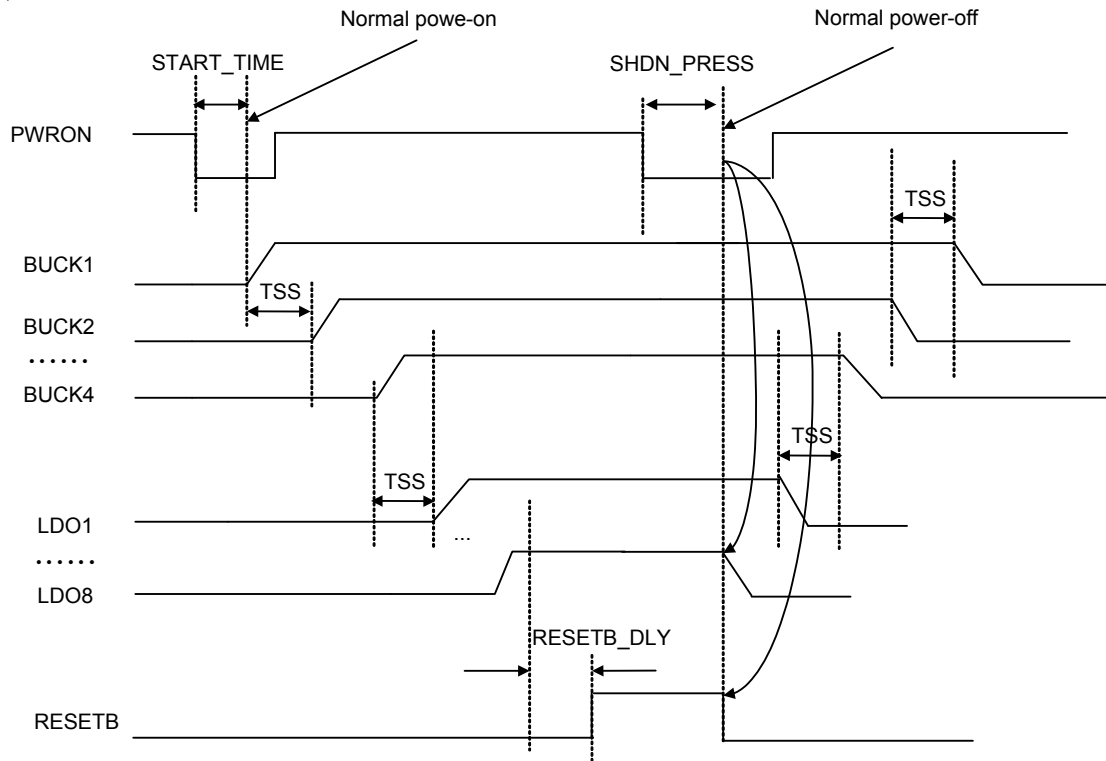

Level Based On/Off Sequence

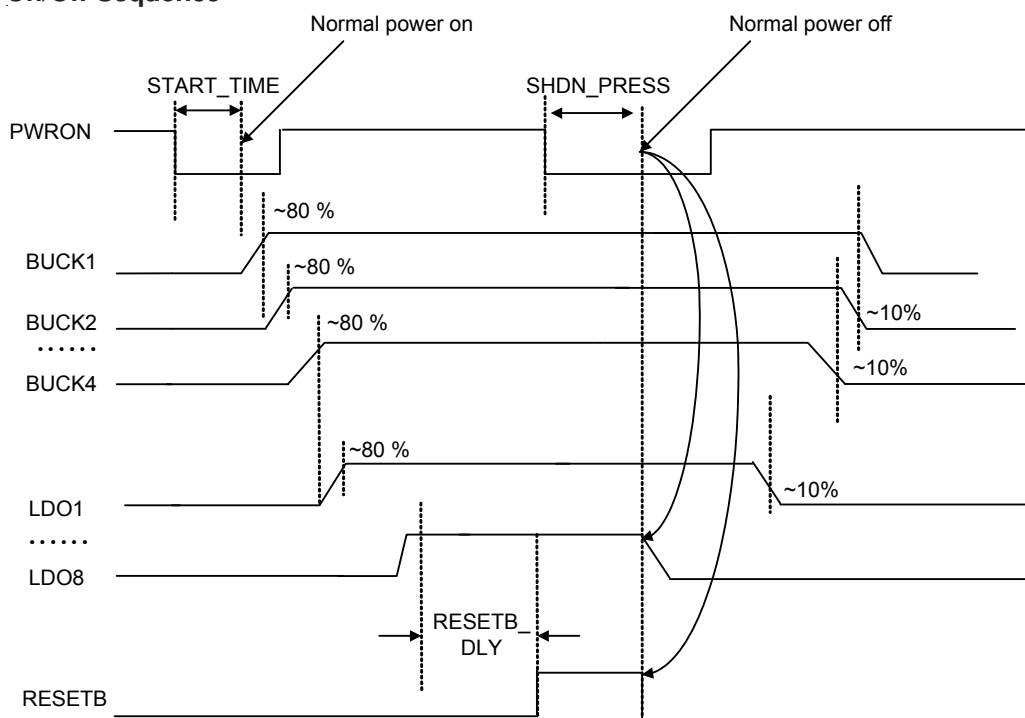

Abnormal Off

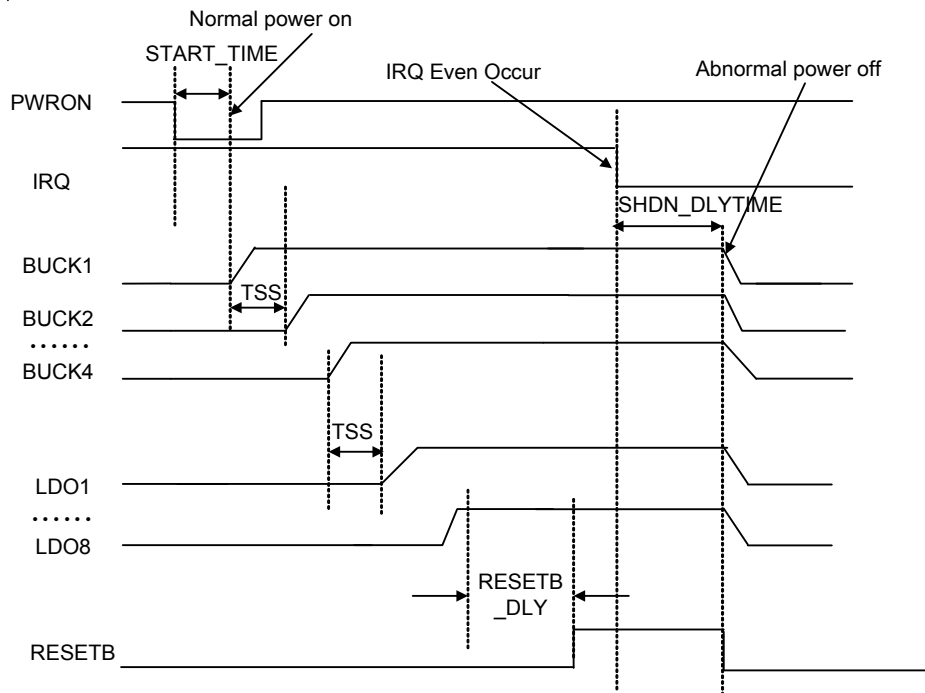

Standby mode and wake up by power-on

Sequentially (STANDBY_OFF = 1) example : Enable2, Enable4 turn-off

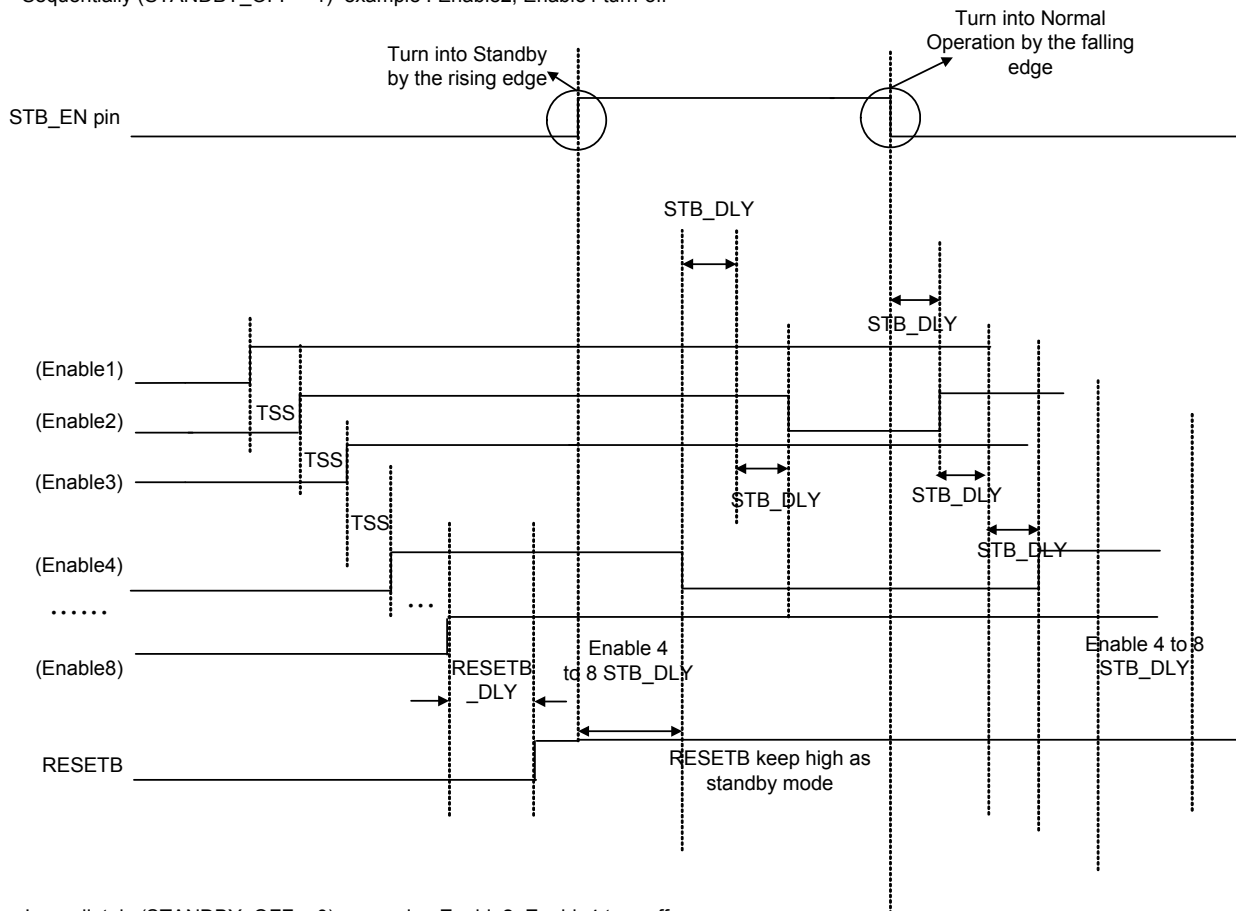

Immediately (STANDBY_OFF = 0) example : Enable2, Enable4 turn-off

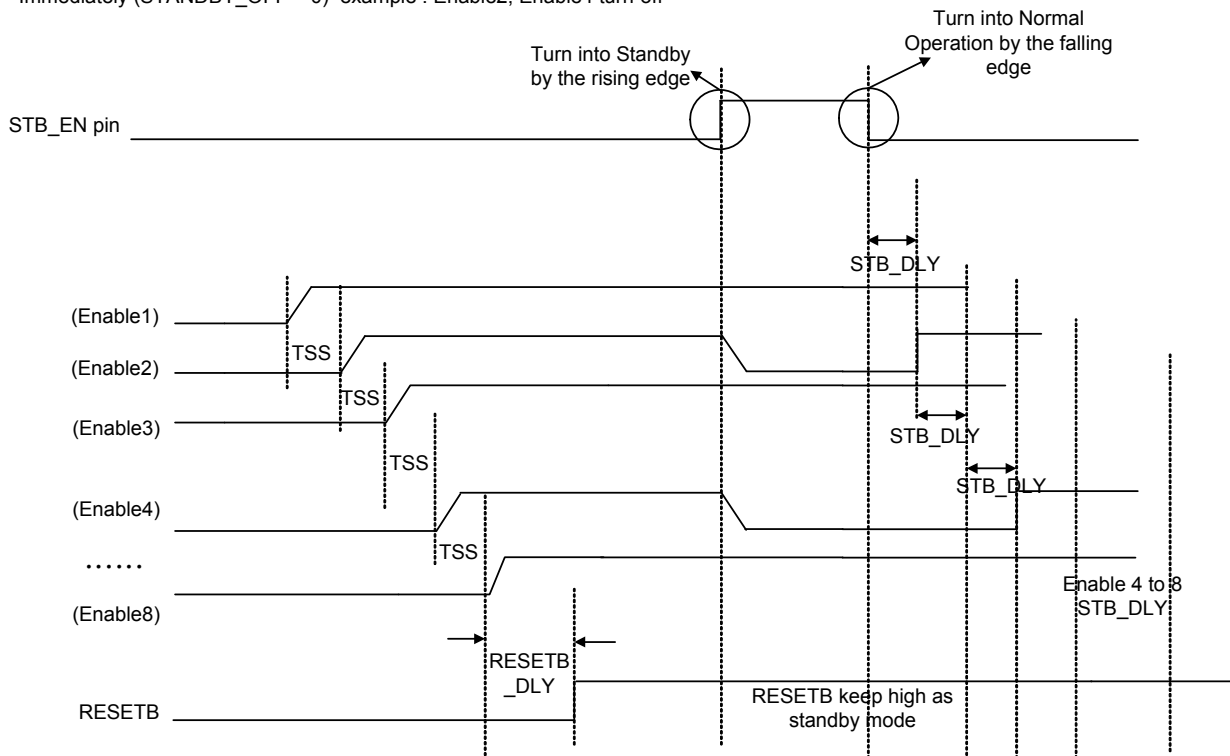

Typical Operating Characteristics

Buck1 Load Regulation

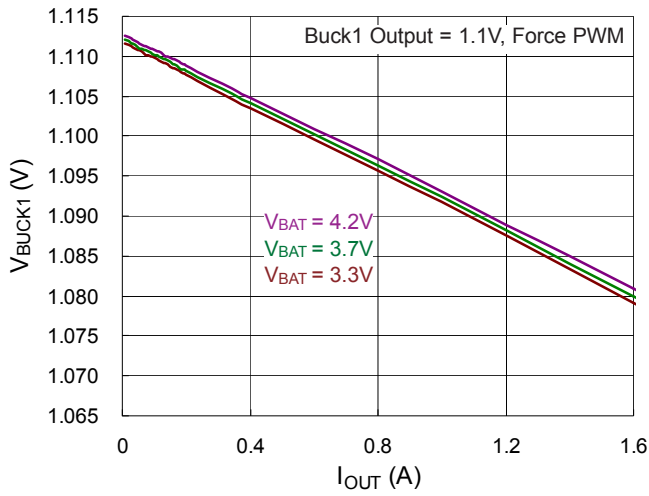

Buck1 Efficiency

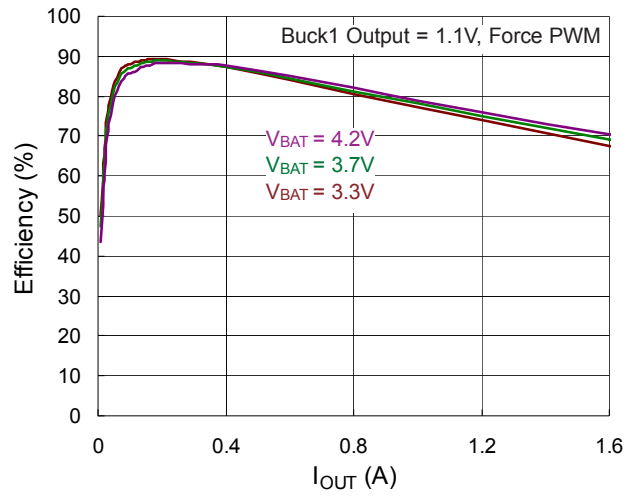

Buck2 Load Regulation

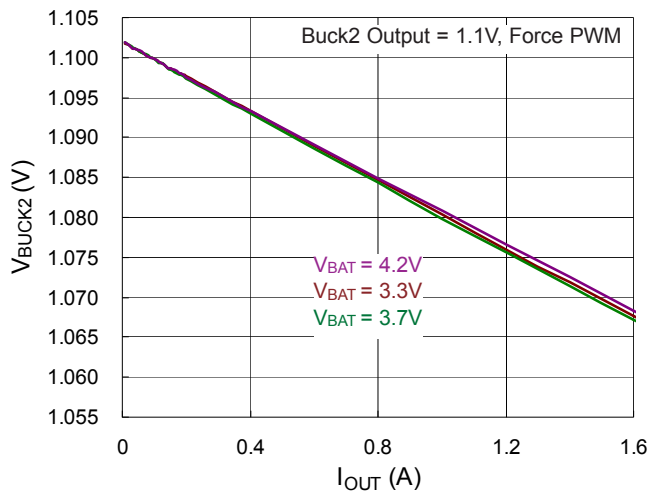

Buck2 Efficiency

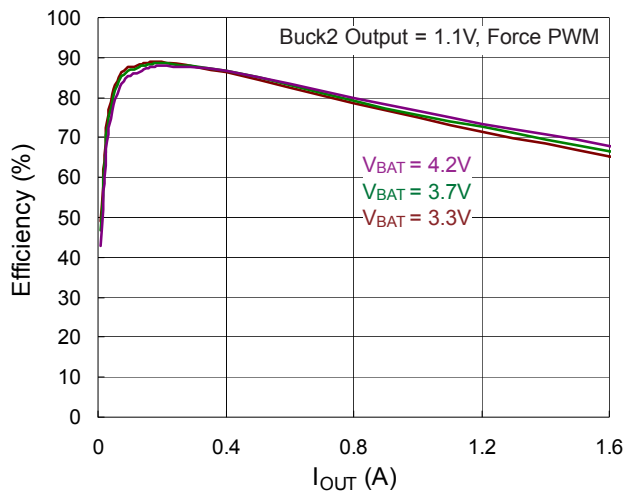

Buck3 Load Regulation

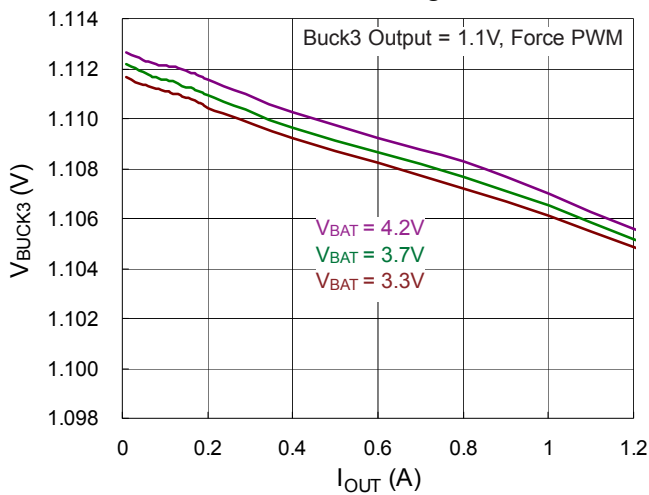

Buck3 Efficiency

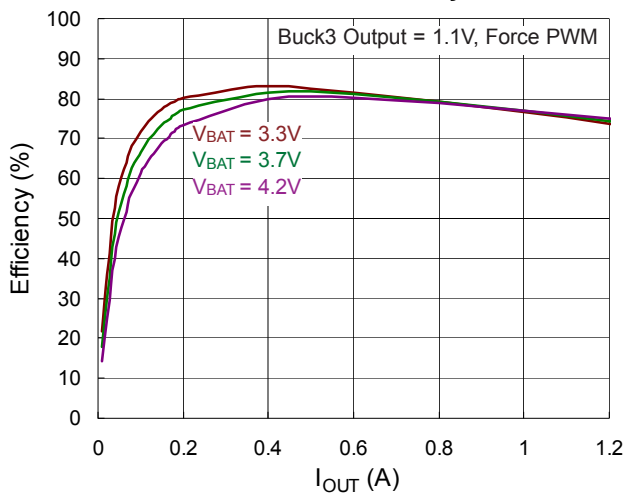

Buck4 Load Regulation

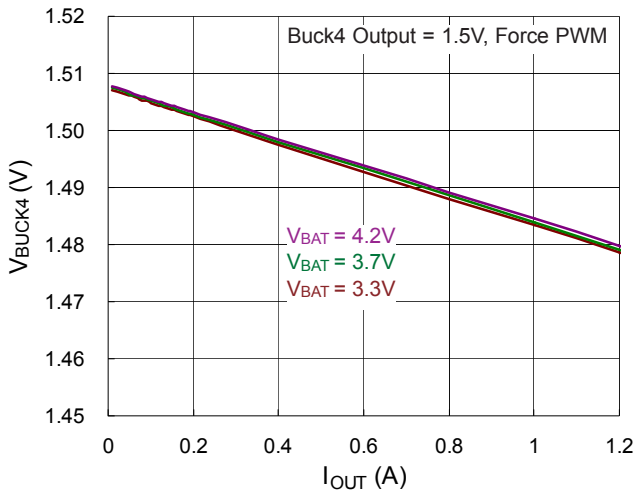

Buck4 Efficiency

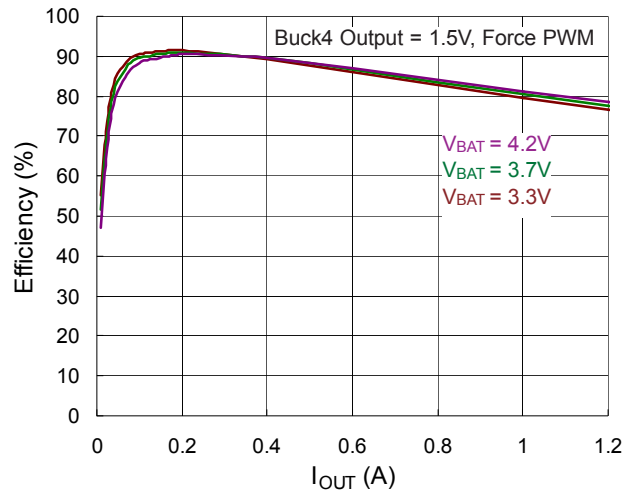

Application Information

Switching Charger

The switching charger integrates a synchronous PWM controller with power MOSFETs to provide Minimum Input Voltage Regulation (MIVR), Average Input Current Regulation (AICR), high accuracy current and voltage regulation, and charge termination. The charger also features OTG-Boost (On-The-Go).

The switching charger has two operation modes: charge mode, and boost mode (OTG-Boost). In charge mode, the switching charger supports a precision charging system for single cell. In boost mode, the switching charger works as the boost converter and boosts the voltage from battery to VINCHG pin for sourcing the OTG devices.

Notice that the switching charger does not integrate input power source (AC adapter or USB input) charging detection. Thus, the switching charger does not set the charge current automatically. The charge current needs to be set via I²C interface by the host. The switching charger application mechanism and I²C compatible interface are introduced in later sections.

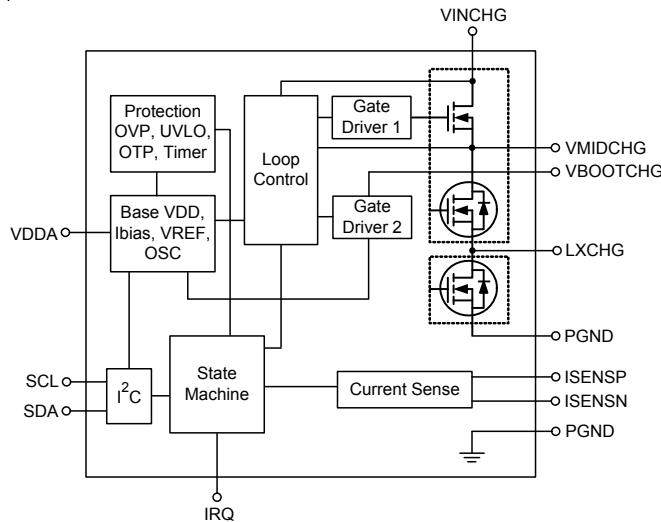

Figure 1. Switching Charger Function Block Diagram

Charge Mode Operation

Minimum Input Voltage Regulation (MIVR)

The switching charger features Minimum Input Voltage Regulation function to prevent input voltage drop due to insufficient current provided by the adaptor or USB input. If MIVR function is enabled, the input voltage decreases when the over current of the input power source occurs. VINCHG is regulated at a predetermined voltage level which can be set as 4.2V to 4.8V per 0.1V by I²C interface. At this time, the current drawn by the switching charger equals to the maximum current value that the input power can provide at the predetermined voltage level, instead of the set value.

Table 1. MIVR Register Setting Table

MIVR[2:0]	V _{MIVR}
000	Disable
001	4.2V
010	4.3V
011	4.4V
100	4.5V (default)
101	4.6V
110	4.7V
111	4.8V

Charge Profile

The switching charger provides a precision Li-ion or Li-polymer charging solution for single-cell applications. Input current limit, charge current, termination current, charge voltage and input voltage MIVR are all programmable via the I²C interface. In charge mode, the switching charger has five control loops to regulate input current, charge current, charge voltage, input voltage MIVR and device junction temperature. During the charging process, all five loops (if MIVR is enabled) are enabled and the dominant one will take over the control.

For normal charging process, the Li-ion or Li-polymer battery is charged in three charging modes depending on the battery voltage. At the beginning of the charging process, the switching charger is in pre-charge mode. When the battery voltage rises above pre-charge threshold

voltage (V_{PREC}), the switching charger enters fast-charge mode. Once the battery voltage is close to the regulation voltage (V_{BATREG}), the switching charger enters constant voltage mode.

Pre-Charge Mode

For life-cycle consideration, the battery cannot be charged with large current under low battery condition. When the VBATS pin voltage is below pre-charge threshold voltage (V_{PREC}), the charger is in pre-charge mode with a weak charge current which equals to the pre-charge current (I_{PREC}). In pre-charge mode, the charger basically works as a Linear Charger. The pre-charge current also acts as the current limit when the VBATS pin is shorted.

The Pre-Charge current levels are 150mA to 450mA programmed by I^2C per 100mA.

Table 2. VPREC Register Setting Table

VPREC[2:0]	Pre-Charge Threshold
0000	2.3V
0001	2.4V
0010	2.5V
0011	2.6V
0100	2.7V
0101	2.8V
0110	2.9V
0111	3V
1000	3.1V
1001	3.2V
1010	3.3V
1011	3.4V
1100	3.5V (Default)
1101	3.6V
1110	3.7V
1111	3.8V

Table 3. IPREC Register Setting Table

IPREC[1:0]	Pre-Charge Current
00	150mA (Default)
01	250mA
10	350mA
11	450mA

Fast-Charge Mode and Settings

As the VBATS pin rises above V_{PREC} , the charger enters fast-charge mode and starts switching. Notice that the switching charger does not integrate input power source (AC adapter or USB input) detection. Thus, the switching charger does not set the charge current automatically. Unlike the linear charger (LDO), the switching charger (Buck converter) is a current amplifier. The current drawn by the switching charger is different from the current into the battery. The user can set the Average Input Current Regulation (AICR) and output charge current (I_{CHRG}) respectively.

Cycle-by-Cycle Current Limit

The charger of the switching charger has an embedded cycle-by-cycle current limit for inductor. Once the inductor current touches the threshold, the charger stops charging immediately to prevent over current from damaging the device. Notice that, the mechanism cannot be disabled by any way.

Average Input Current Regulation (AICR)

The AICR setting is controlled by I^2C . The AICR100 mode limits the input current to 100mA. The AICR500 mode limits the input current to 500mA.. If the application does not need input current limit, it can be disabled also.

The AICR levels are as below table and programmed by I^2C and suitable for USB port and several TA types (5V/0.7A, 5V/1A, 5V/2A).

Table 4. AICR Register Setting Table

AICR[2:0]	I _{AICR}
000	Disable
001	0.1A
010	0.5A
011	0.7A
100	0.9A (Default)
101	1A
110	1.5A
111	2A

Charge Current (I_{CHRG})

The charge current into the battery is determined by the sense resistor (R_{SENSE}) and ICC setting by I²C. The voltage between the ISENSP and ISENSN pins is regulated to the voltage control by ICC setting.

As the R_{SENSE} is 20mΩ, the Fast-Charge currents are 700mA to 2A programmed by I²C per 100mA.

Table 5. ICHG Register Setting Table

ICHG[3:0]	VCC	ICHG R _{SENSE} is 20mΩ
0000	10mV	0.5A
0001	12mV	0.6A
0010	14mV	0.7A
0011	16mV	0.8A
0100	18mV	0.9A
0101	20mV	1A
0110	22mV	1.1A
0111	24mV	1.2A
1000	26mV	1.3A
1001	28mV	1.4A
1010	30mV	1.5A (Default)
1011	32mV	1.6A
1100	34mV	1.7A
1101	36mV	1.8A
1110	38mV	1.9A
1111	40mV	2A

Constant Voltage Mode and Settings

The switching charger enters constant voltage mode when the ISENSN voltage is close to the output-charge voltage (V_{BATREG}). Once in this mode, the charge current begins to decrease. For default settings (charge current termination is disabled), the switching charger does not turn off and always regulates the battery voltage at V_{BATREG}. However, once the charge current termination is enabled, the charger terminates if the charge current is below termination current (I_{EOC}) in constant-voltage mode. The charge current termination function is controlled by the I²C interface. After termination, a new charge cycle restarts when one of the following conditions is detected :

- ▶ The VBATS pin voltage falls below the VBATREG as V_{REC} threshold.
- ▶ VINCHG Power-On Reset (POR).
- ▶ Charge or Termination Enable bit toggle or Charger reset (via I²C interface).

Output Charge Voltage (VBATREG)

The output-charge voltage is set by the I²C interface. Its range is from 3.65V to 4.4V per 25mV.

Termination Current (I_{EOC})

If the charger current termination is enabled (TE bit = “1”), the end-of-charge current is determined by both the termination current sense voltage (V_{EOC}) and sense resistor (R_{SENSE}). As R_{SENSE} is 20mΩ, I_{EOC} is set by the I²C interface from 150mA to 600mA per 50mA.

Table 6. EOC Register Setting Table

EOC[2:0]	VEOC	I _{EOC} R _{SENSE} is 20mΩ
000	Disable	Disable
001	3mV	150mA
010	4mV	200mA
011	5mV	250mA (default)
100	6mV	300mA
101	8mV	400mA
110	10mV	500mA
111	12mV	600mA

Input Voltage Protection in Charge Mode

During charge mode, there are two protection mechanisms against if input power source capability is less than the charging current setting. One is AICR and the other is minimum input voltage regulation. A suitable level of AICR can prevent VINCHG drop by the insufficient capability. As the AICR setting is not suitable, MIVR will regulate the VINCHG in the setting level and sink the maximum current of power source.

Sleep Mode ($V_{VINCHG} - V_{VBATS} < V_{SLP}$)

The switching charger enters sleep mode if the voltage drop between the VINCHG and VBATS pins falls below VSLP. In sleep mode, the reverse blocking switch and PWM are all turned off. This function prevents battery drain during poor or no input power source.

Input Over Voltage Protection

When VINCHG rises above the input over voltage threshold, the switching charger stops charging and then sets fault status bits. The condition is released when VINCHG falls below OVP threshold. The switching charger then resumes charging operation.

Reverse Boost Mode Operation (OTG)

Trigger and Operation

The switching charger features OTG-Boost support. When OTG function is enabled, the synchronous boost control loop takes over the power MOSFETs and reverses the power flow from the battery to the VINCHG pin. In normal boost mode, the VMIDCHG pin is regulated to 5V (typ.) to support other OTG devices connected to the USB connector.

Output Over-Voltage Protection

In boost mode, the output over voltage protection is triggered when the VMIDCHG voltage is above the output

OVP threshold. When OVP occurs, the boost converter stops switching and turns off immediately.

Battery Protection

Battery Over-Voltage Protection in Charge Mode

The switching charger monitors the ISENSEN voltage for output over voltage protection. In charge mode, if the ISENSEN voltage rises above $V_{OVP_BAT} \times V_{BATREG}$, such as when the battery is suddenly removed, the switching charger stops charging and then sets fault status bits and sends out fault pulse at the STAT pin. The condition is released when the ISENSEN voltage falls below $(V_{OVP_BAT} - \Delta V_{OVP_BAT}) \times V_{OVP_BAT}$. The switching charger then resumes charging process with default settings and the fault is cleared.

Bucks

The RT5036 includes a synchronous step-down DC/DC converter that can support the input voltage range from 2.7V to 5.5V. The output current is up to 600mA. The output voltage can be programmable by I²C. Following shows the function block of the RT5036 buck.

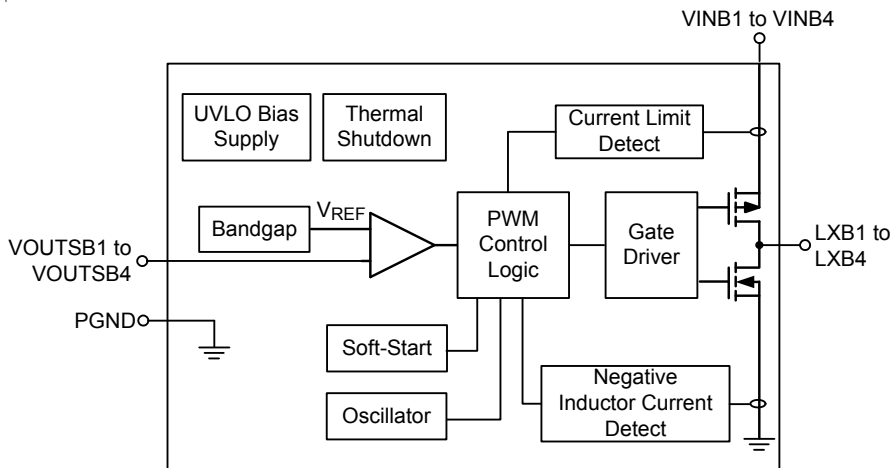

Figure 2. Buck Function Block Diagram

Normally, the high-side MOSFET is turned on by the PWM control logic block which drives the gate driver block when VOUTSB1 to VOUTSB4 is lower than the internal reference voltage. After VOUTSB1 to VOUTSB4 is higher than the internal reference voltage, the high side MOSFET will be turned off. While the high side MOSFET is turned off, the low side MOSFET is turned on until the current of the inductor is around zero by the negative inductor current detection block.

When the current of high side MOSFET is over the rating current, the high side MOSFET is turned off. When the temperature is over the rating temperature, the high side

MOSFET is turned off until the temperature is dropped by the thermal shutdown block. After the thermal shutdown is released, VOUTSB1 to VOUTSB4 will be soft-started again.

IRQ Operation

RT5036 summarize all IRQ items in the register table. All IRQ_status registers are implemented as reset after read. And IRQ pin is released only after IRQ_PRez bit is set. If IRQ Mask bit is High, the IRQ_status bit will not update status. IRQ_enable will mask IRQ_status to trigger IRQ Low, so the system can decide which interrupt is necessary.