



Chipsmall Limited consists of a professional team with an average of over 10 year of expertise in the distribution of electronic components. Based in Hongkong, we have already established firm and mutual-benefit business relationships with customers from,Europe,America and south Asia,supplying obsolete and hard-to-find components to meet their specific needs.

With the principle of "Quality Parts,Customers Priority,Honest Operation,and Considerate Service",our business mainly focus on the distribution of electronic components. Line cards we deal with include Microchip,ALPS,ROHM,Xilinx,Pulse,ON,Everlight and Freescale. Main products comprise IC,Modules,Potentiometer,IC Socket,Relay,Connector.Our parts cover such applications as commercial,industrial, and automotives areas.

We are looking forward to setting up business relationship with you and hope to provide you with the best service and solution. Let us make a better world for our industry!



## Contact us

Tel: +86-755-8981 8866 Fax: +86-755-8427 6832

Email & Skype: info@chipsmall.com Web: www.chipsmall.com

Address: A1208, Overseas Decoration Building, #122 Zhenhua RD., Futian, Shenzhen, China



## 4A, 2MHz, Synchronous Step-Down Converter

### General Description

The RT8074 is a high efficiency synchronous, step-down DC/DC converter. Its input voltage range is from 2.7V to 5.5V and provides an adjustable regulated output voltage from 0.8V to 5V while delivering up to 4A of output current.

The internal synchronous low on-resistance power switches increase efficiency and eliminate the need for an external Schottky diode. The default switching frequency is set at 2MHz, if the RT pin is left open. It can also be varied from 200kHz to 2MHz by adding an external resistor. Current mode operation with external compensation allows the transient response to be optimized over a wide range of loads and output capacitors.

### Ordering Information

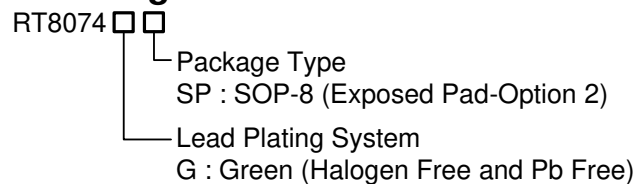

Note :

Richtek products are :

- ▶ RoHS compliant and compatible with the current requirements of IPC/JEDEC J-STD-020.
- ▶ Suitable for use in SnPb or Pb-free soldering processes.

### Features

- High Efficiency : Up to 95%
- Adjustable Frequency : 200kHz to 2MHz
- No Schottky Diode Required
- 0.8V Reference Allows Low Output Voltage
- Low Dropout Operation : 100% Duty Cycle
- Enable Function
- Internal Soft-Start
- RoHS Compliant and Halogen Free

### Applications

- LCD TV and Monitor
- Notebook Computers
- Distributed Power Systems
- IP Phones
- Digital Cameras

### Pin Configurations

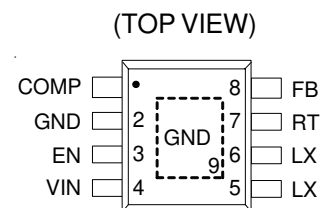

SOP-8 (Exposed Pad)

### Typical Application Circuit

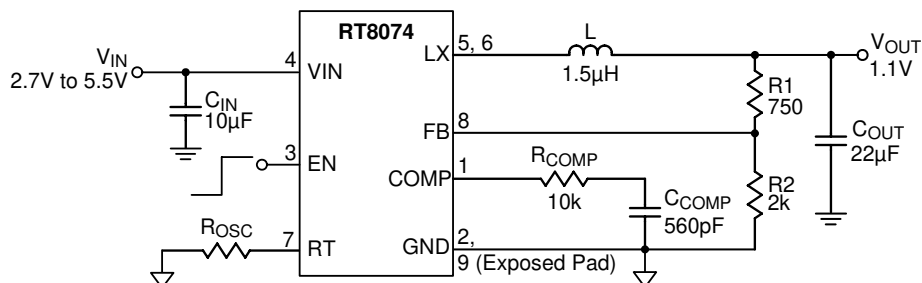

**Note : Using all Ceramic Capacitors**

## Marking Information

RT8074 GSPYMDNN •
-------------------------

RT8074GSP : Product Number  
 YMDNN : Date Code

## Functional Pin Description

Pin No.	Pin Name	Pin Function
1	COMP	Error Amplifier Compensation Point. The current comparator threshold increases with this control voltage. Connect external compensation elements to this pin to stabilize the control loop.
2, 9 (Exposed Pad)	GND	Ground. The exposed pad must be soldered to a large PCB and connected to GND for maximum power dissipation.
3	EN	Enable Control Input. Float or connect this pin to logic high for enable. Connect to GND for disable.
4	VIN	Power Input Supply. Decouple this pin to GND with a capacitor.
5, 6	LX	Internal Power MOSFET Switches Output. Connect this pin to the inductor.
7	RT	Oscillator Resistor Input. Connecting a resistor from this pin to GND sets the switching frequency. If this pin is floating, the frequency will be set at 2MHz internally.
8	FB	Feedback. Receives the feedback voltage from a resistive divider connected across the output.

## Function Block Diagram

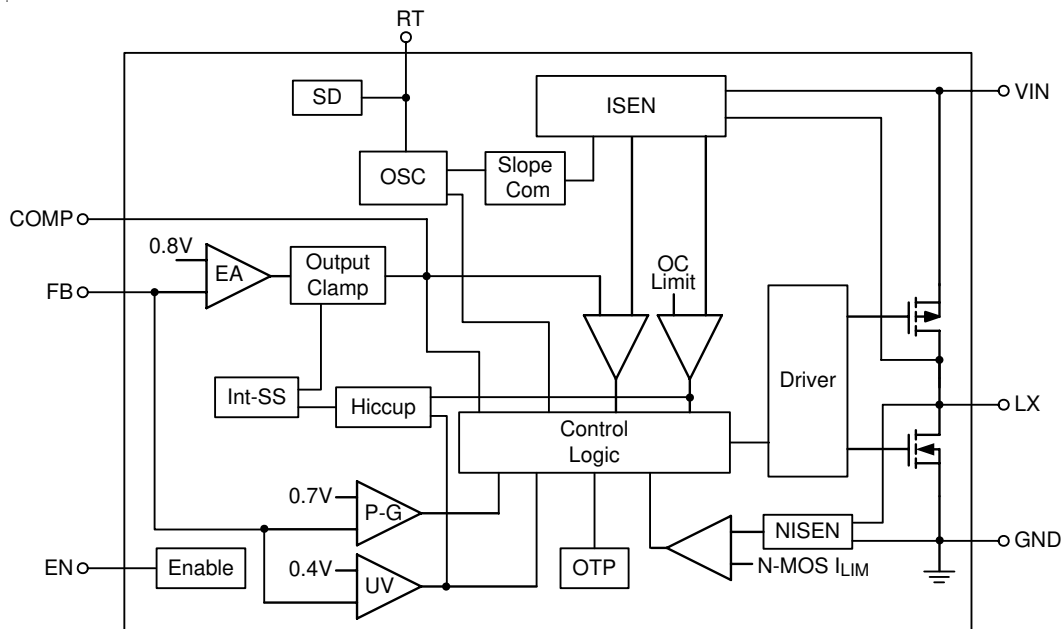

**Absolute Maximum Ratings** (Note 1)

- Supply Input Voltage,  $V_{IN}$  ----- -0.3V to 6.5V
- LX Pin Switch Voltage ----- -0.3V to ( $V_{IN} + 0.3V$ )
- <10ns ----- -5V to 8.5V
- Other I/O Pin Voltages ----- -0.3V to ( $V_{IN} + 0.3V$ )
- LX Pin Switch Current ----- 5A
- Power Dissipation,  $P_D$  @  $T_A = 25^\circ C$
- SOP-8 (Exposed Pad) ----- 1.33W
- Package Thermal Resistance (Note 2)
- SOP-8 (Exposed Pad),  $\theta_{JA}$  -----  $75^\circ C/W$
- SOP-8 (Exposed Pad),  $\theta_{JC}$  -----  $15^\circ C/W$
- Junction Temperature -----  $150^\circ C$
- Lead Temperature (Soldering, 10 sec.) -----  $260^\circ C$
- Storage Temperature Range -----  $-65^\circ C$  to  $150^\circ C$
- ESD Susceptibility (Note 3)
- HBM (Human Body Model) ----- 2kV

**Recommended Operating Conditions** (Note 4)

- Supply Input Voltage,  $V_{IN}$  ----- 2.7V to 5.5V
- Junction Temperature Range -----  $-40^\circ C$  to  $125^\circ C$
- Ambient Temperature Range -----  $-40^\circ C$  to  $85^\circ C$

**Electrical Characteristics**

( $V_{IN} = 3.3V$ ,  $T_A = 25^\circ C$ , unless otherwise specified)

Parameter		Symbol	Test Conditions	Min	Typ	Max	Unit
Feedback Reference Voltage		$V_{REF}$		0.784	0.8	0.816	V
DC Bias Current			Active , $V_{FB} = 0.78V$ , Not Switching	--	460	--	$\mu A$
			Shutdown	--	--	10	
Output Voltage Line Regulation			$V_{IN} = 2.7V$ to $5.5V$	--	0.1	--	%/V
Output Voltage Load Regulation			$0A < I_{LOAD} < 4A$	--	0.25	--	%
Error Amplifier Trans-conductance		gm		--	400	--	$\mu A/V$
Current Sense Trans-resistance		$R_T$		--	0.3	--	$\Omega$
Switching Frequency		$f_{SW}$	$R_{OSC} = 330k\Omega$	0.8	1	1.2	MHz
			Switching	0.2	--	2	
EN Input Voltage	Logic-High	$V_{IH}$		1.6	--	--	V
	Logic-Low	$V_{IL}$		--	--	0.4	
Switch On Resistance, High		$R_{DS(ON)_P}$	$I_{LX} = 0.5A$	--	110	180	m $\Omega$
Switch On Resistance, Low		$R_{DS(ON)_N}$	$I_{LX} = 0.5A$	--	70	120	m $\Omega$

Parameter	Symbol	Test Conditions	Min	Typ	Max	Unit
Peak Current Limit	$I_{LIM}$	(Note 5)	4.7	5.8	--	A
Under Voltage Lockout Threshold		$V_{IN}$ Rising	--	2.4	--	V
		$V_{IN}$ Falling	--	2.2	--	
RT Shutdown Threshold	$V_{RT}$		--	$V_{IN} - 0.7$	$V_{IN} - 0.4$	V

**Note 1.** Stresses beyond those listed “Absolute Maximum Ratings” may cause permanent damage to the device. These are stress ratings only, and functional operation of the device at these or any other conditions beyond those indicated in the operational sections of the specifications is not implied. Exposure to absolute maximum rating conditions may affect device reliability.

**Note 2.**  $\theta_{JA}$  is measured at  $T_A = 25^\circ\text{C}$  on a high effective thermal conductivity four-layer test board per JEDEC 51-7.  $\theta_{JC}$  is measured at the exposed pad of the package.

**Note 3.** Devices are ESD sensitive. Handling precaution is recommended.

**Note 4.** The device is not guaranteed to function outside its operating conditions.

**Note 5.** The RT8074 package surface temperature is about  $60^\circ\text{C}$  when the current is 3.15A. It is based on the 4-layer PCB referred in the layout considerations section.

**Typical Operating Characteristics**

**Efficiency vs. Output Current**

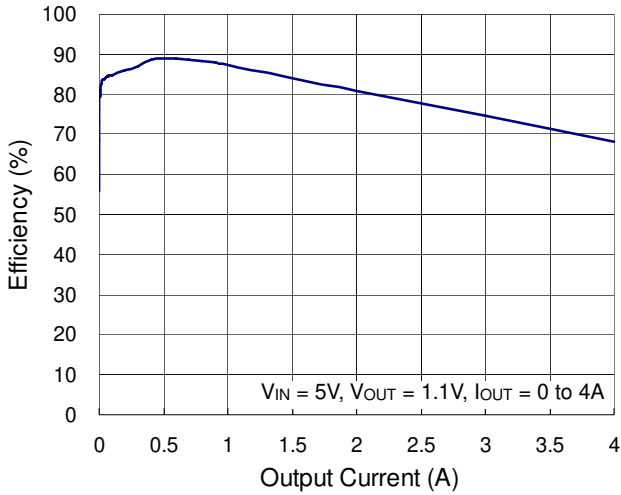

**Output Voltage vs. Output Current**

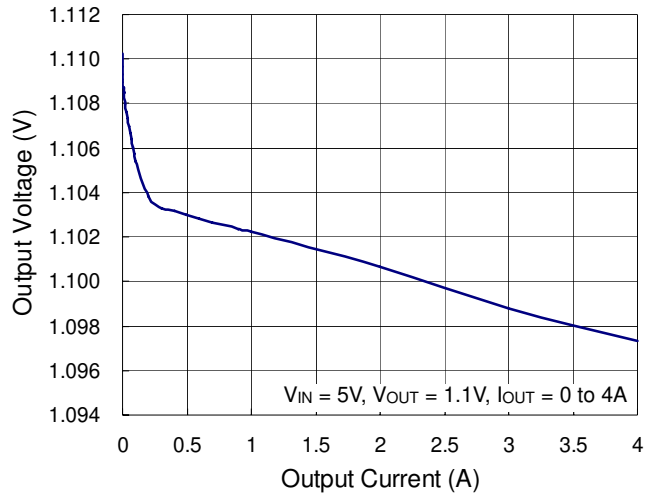

**Switching Frequency vs. Temperature**

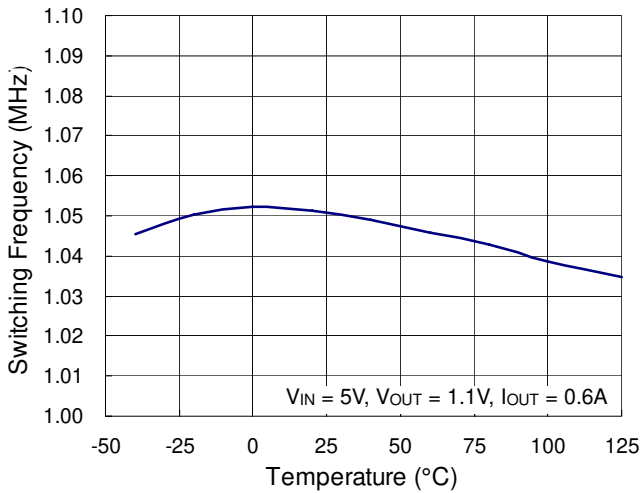

**Reference Voltage vs. Temperature**

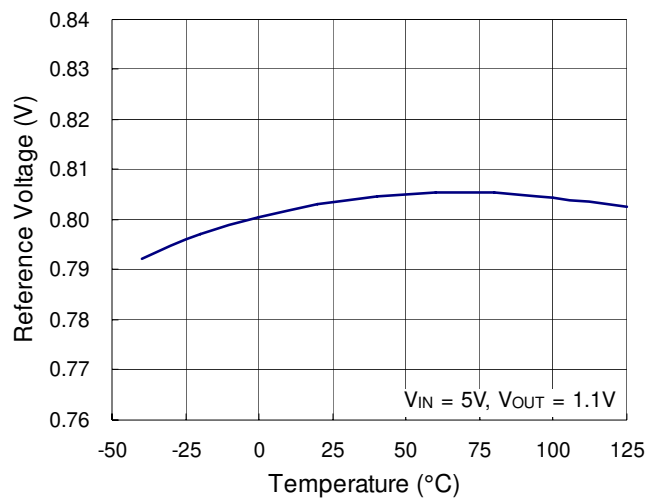

**V<sub>IN</sub> UVLO vs. Temperature**

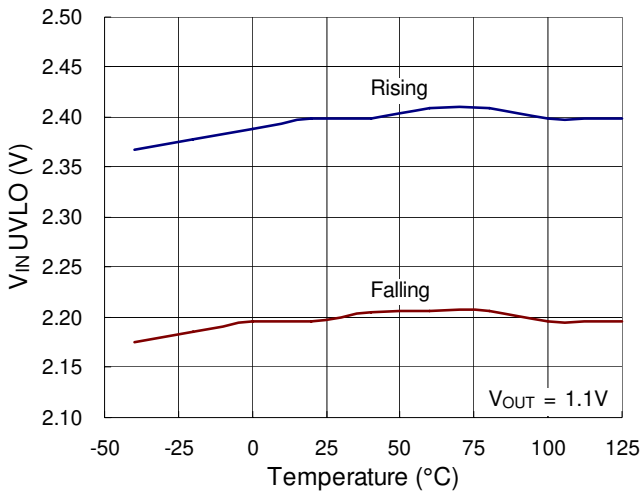

**Enable Voltage vs. Temperature**

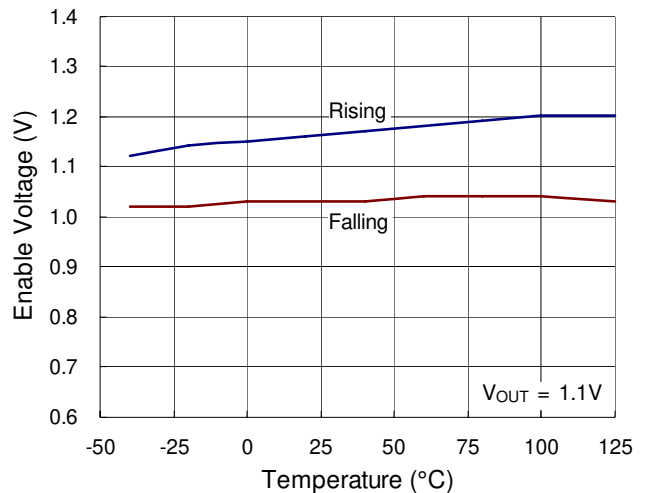

Output Ripple

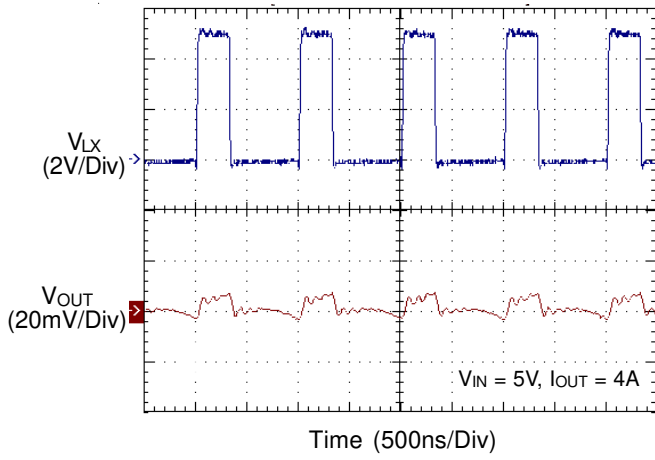

Load Transient Response

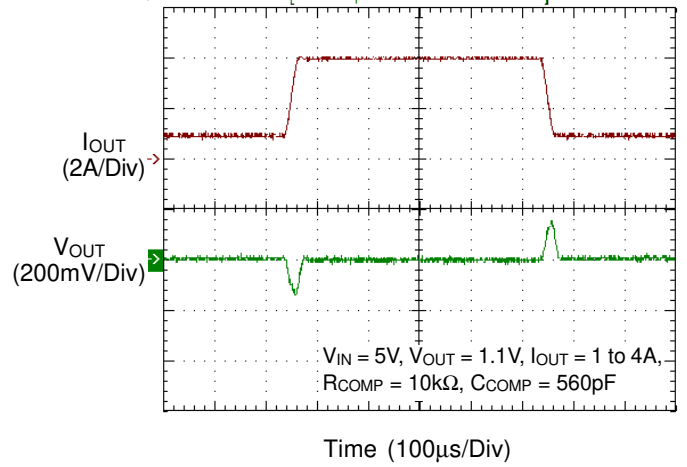

Power On from EN

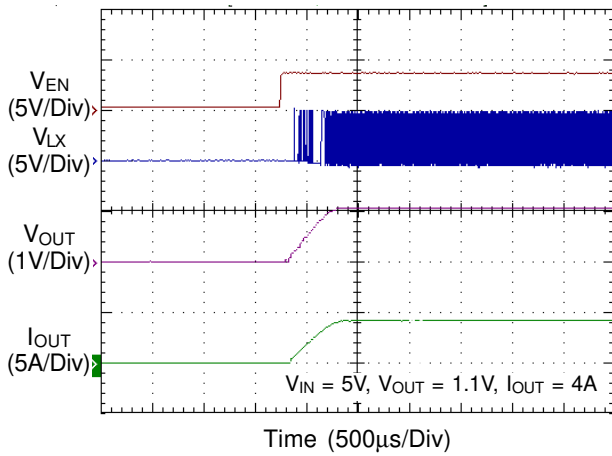

Power Off from EN

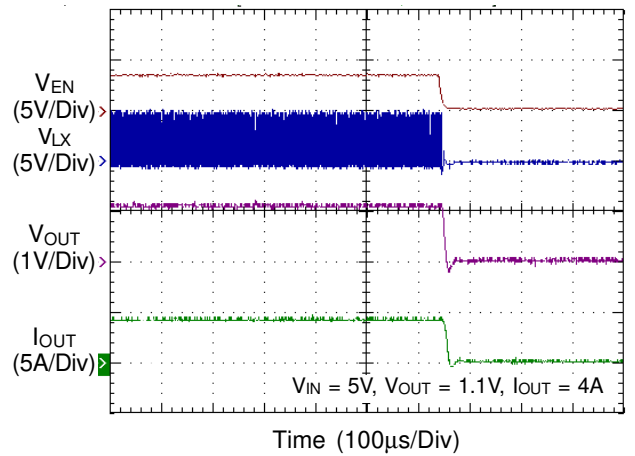

### Application Information

The basic IC application circuit is shown in Typical Application Circuit. External component selection is determined by the maximum load current and begins with the selection of the inductor value and operating frequency followed by  $C_{IN}$  and  $C_{OUT}$ .

#### Main Control Loop

During normal operation, the internal high side power switch (P-MOSFET) is turned on at the beginning of each clock cycle. The inductor current increases until it reaches the value defined by the output voltage ( $V_{COMP}$ ) of the error amplifier. The error amplifier adjusts its output voltage by comparing the feedback signal from a resistive voltage divider on the FB pin with an internal 0.8V reference. When the load current increases, it causes a reduction in the feedback voltage relative to the reference. The error amplifier increases its output voltage until the average inductor current matches the new load current. When the high side power MOSFET shuts off, the synchronous power switch (N-MOSFET) turns on until the beginning of the next clock cycle.

#### Output Voltage Setting

The output voltage is set by an external resistive voltage divider according to the following equation :

$$V_{OUT} = V_{REF} \times \left(1 + \frac{R1}{R2}\right)$$

where  $V_{REF}$  is 0.8V typical. The resistive voltage divider allows the FB pin to sense a fraction of the output voltage as shown in Figure 1.

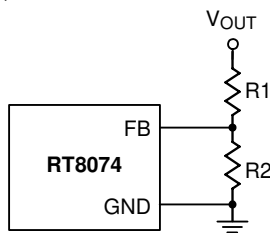

Figure 1. Setting the Output Voltage

#### Soft-Start

The RT8074 includes an internal soft-start function that gradually raises the clamp on the COMP pin.

#### Operating Frequency

Selection of the operating frequency is a tradeoff between efficiency and component size. High frequency operation allows the use of smaller inductor and capacitor values, but at the expense of efficiency. On the other hand, operation at lower frequency improves efficiency by reducing internal gate charge and switching losses, but requires larger inductance and/or capacitance to maintain low output ripple voltage.

The operating frequency of the IC is determined by an external resistor,  $R_{OSC}$ , that is connected between the RT pin and ground. The value of the resistor sets the ramp current that is used to charge and discharge an internal timing capacitor within the oscillator. The practical switching frequency ranges from 200kHz to 2MHz. However, when the RT pin is floating, the internal frequency is set at 2MHz. Determine the RT resistor value by examining the curve below. Please notice the minimum on time is about 90ns.

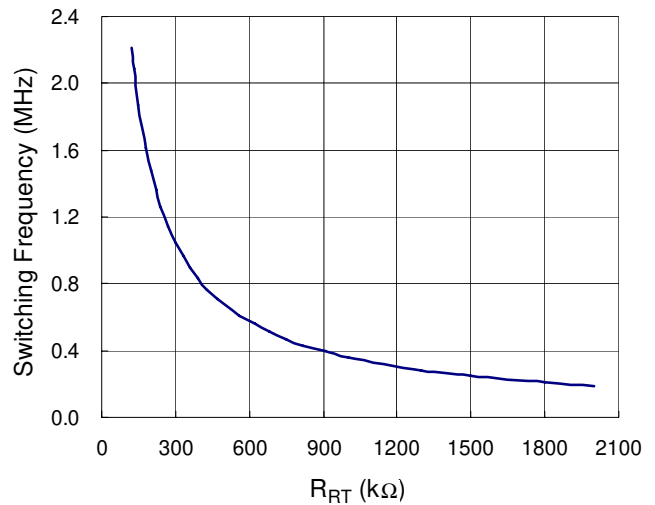

Figure 2. Switching Frequency vs.  $R_{RT}$  Resistor

#### Inductor Selection

For a given input and output voltage, the inductor value and operating frequency determine the ripple current. The ripple current,  $\Delta I_L$ , increases with higher  $V_{IN}$  and decreases with higher inductance :

$$\Delta I_L = \left[ \frac{V_{OUT}}{f \times L} \right] \left[ 1 - \frac{V_{OUT}}{V_{IN}} \right]$$

Having a lower ripple current reduces not only the ESR losses in the output capacitors but also the output voltage ripple. Highest efficiency operation is achieved by reducing ripple current at low frequency, but it requires a large inductor to attain this goal.

For the ripple current selection, the value of  $\Delta I_L = 0.4 (I_{MAX})$  will be a reasonable starting point. The largest ripple current occurs at the highest  $V_{IN}$ . To guarantee that the ripple current stays below a specified maximum, the inductor value should be chosen according to the following equation :

$$L = \left[ \frac{V_{OUT}}{f \times \Delta I_L(MAX)} \right] \left[ 1 - \frac{V_{OUT}}{V_{IN(MAX)}} \right]$$

### Using Ceramic Input and Output Capacitors

Higher value, lower cost ceramic capacitors are now becoming available in smaller case sizes. Their high ripple current, high voltage rating and low ESR make them ideal for switching regulator applications. However, care must be taken when these capacitors are used at the input and output. When a ceramic capacitor is used at the input and the power is supplied by a wall adapter through long wires, a load step at the output can induce ringing at the input  $V_{IN}$ . At best, this ringing can couple to the output and be mistaken as loop instability. At worst, a sudden inrush of current through the long wires can potentially cause a voltage spike at  $V_{IN}$  large enough to damage the part.

### Slope Compensation and Inductor Peak Current

Slope compensation provides stability in constant frequency architectures by preventing sub harmonic oscillations at duty cycles greater than 50%. It is accomplished internally by adding a compensating ramp to the inductor current signal. Normally, the maximum inductor peak current is reduced when slope compensation is added. For the RT8074, however, a separate inductor current signal is used to monitor over current condition, so this keeps the maximum output current relatively constant regardless of duty cycle.

### Hiccup Mode Under Voltage Protection

A Hiccup Mode Under Voltage Protection (UVP) function is provided for the IC. When the FB voltage drops below

half of the feedback reference voltage,  $V_{REF}$ , the UVP function will be triggered to auto soft-start the power stage continuously until this event is cleared. The Hiccup Mode UVP reduces input current in short circuit conditions and prevents false triggering during soft-start process.

### Under Voltage Lockout Threshold

The IC features input under voltage lockout protection (UVLO). If the input voltage exceeds the UVLO rising threshold voltage, the converter will reset and prepare the PWM for operation. If the input voltage falls below the UVLO falling threshold voltage during normal operation, the device will stop switching. The UVLO rising and falling threshold voltage has a hysteresis to prevent noise-caused reset.

### Thermal Considerations

For continuous operation, do not exceed absolute maximum junction temperature. The maximum power dissipation depends on the thermal resistance of the IC package, PCB layout, rate of surrounding airflow, and difference between junction and ambient temperature. The maximum power dissipation can be calculated by the following formula :

$$P_{D(MAX)} = (T_{J(MAX)} - T_A) / \theta_{JA}$$

where  $T_{J(MAX)}$  is the maximum junction temperature,  $T_A$  is the ambient temperature, and  $\theta_{JA}$  is the junction to ambient thermal resistance.

For recommended operating condition specifications, the maximum junction temperature is 125°C. The junction to ambient thermal resistance,  $\theta_{JA}$ , is layout dependent. For SOP-8 (Exposed Pad) packages, the thermal resistance,  $\theta_{JA}$ , is 75°C/W on a standard JEDEC 51-7 four-layer thermal test board. The maximum power dissipation at  $T_A = 25^\circ\text{C}$  can be calculated by the following formula :

$$P_{D(MAX)} = (125^\circ\text{C} - 25^\circ\text{C}) / (75^\circ\text{C/W}) = 1.333\text{W}$$

for SOP-8 (Exposed Pad) package

The maximum power dissipation depends on the operating ambient temperature for fixed  $T_{J(MAX)}$  and thermal resistance,  $\theta_{JA}$ . The derating curve in Figure 3 allows the designer to see the effect of rising ambient temperature on the maximum power dissipation.

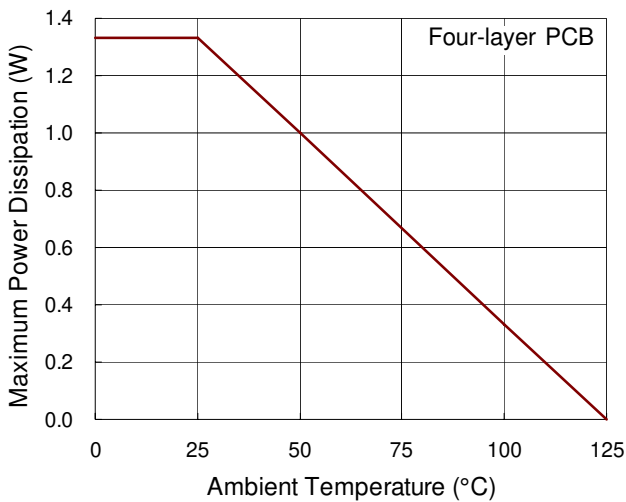

Figure 3. Derating Curve of Maximum Power Dissipation

**Layout Considerations**

Follow the PCB layout guidelines for optimal performance of the IC.

- ▶ Connect the terminal of the input capacitor(s),  $C_{IN}$ , as close as possible to the  $V_{IN}$  pin. This capacitor provides the AC current into the internal power MOSFETs.
- ▶ LX node experiences high frequency voltage swing and should be kept within a small area.
- ▶ Keep all sensitive small signal nodes away from the LX node to prevent stray capacitive noise pick up.
- ▶ Connect the FB pin directly to the feedback resistors. The resistive voltage divider must be connected between  $V_{OUT}$  and GND.

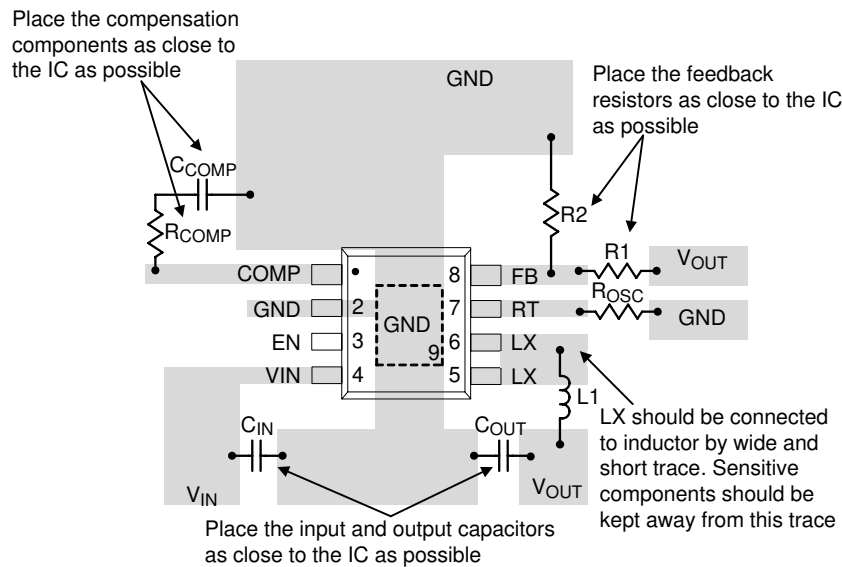
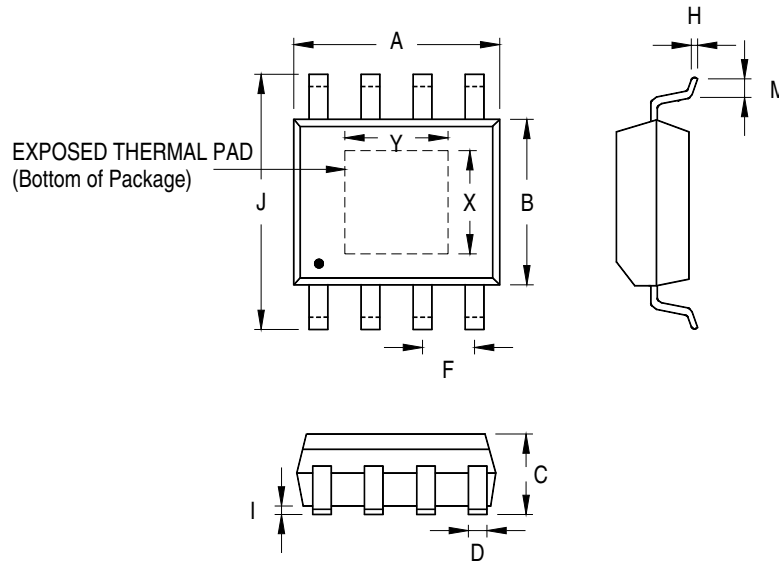

Figure 4. PCB Layout Guide

Outline Dimension



Symbol	Dimensions In Millimeters		Dimensions In Inches		
	Min	Max	Min	Max	
A	4.801	5.004	0.189	0.197	
B	3.810	4.000	0.150	0.157	
C	1.346	1.753	0.053	0.069	
D	0.330	0.510	0.013	0.020	
F	1.194	1.346	0.047	0.053	
H	0.170	0.254	0.007	0.010	
I	0.000	0.152	0.000	0.006	
J	5.791	6.200	0.228	0.244	
M	0.406	1.270	0.016	0.050	
Option 1	X	2.000	2.300	0.079	0.091
	Y	2.000	2.300	0.079	0.091
Option 2	X	2.100	2.500	0.083	0.098
	Y	3.000	3.500	0.118	0.138

8-Lead SOP (Exposed Pad) Plastic Package

Richtek Technology Corporation

5F, No. 20, Taiyuen Street, Chupei City  
 Hsinchu, Taiwan, R.O.C.  
 Tel: (8863)5526789

Richtek products are sold by description only. Richtek reserves the right to change the circuitry and/or specifications without notice at any time. Customers should obtain the latest relevant information and data sheets before placing orders and should verify that such information is current and complete. Richtek cannot assume responsibility for use of any circuitry other than circuitry entirely embodied in a Richtek product. Information furnished by Richtek is believed to be accurate and reliable. However, no responsibility is assumed by Richtek or its subsidiaries for its use; nor for any infringements of patents or other rights of third parties which may result from its use. No license is granted by implication or otherwise under any patent or patent rights of Richtek or its subsidiaries.