



Chipsmall Limited consists of a professional team with an average of over 10 year of expertise in the distribution of electronic components. Based in Hongkong, we have already established firm and mutual-benefit business relationships with customers from,Europe,America and south Asia,supplying obsolete and hard-to-find components to meet their specific needs.

With the principle of “Quality Parts,Customers Priority,Honest Operation,and Considerate Service”,our business mainly focus on the distribution of electronic components. Line cards we deal with include Microchip,ALPS,ROHM,Xilinx,Pulse,ON,Everlight and Freescale. Main products comprise IC,Modules,Potentiometer,IC Socket,Relay,Connector.Our parts cover such applications as commercial,industrial, and automotives areas.

We are looking forward to setting up business relationship with you and hope to provide you with the best service and solution. Let us make a better world for our industry!



## Contact us

Tel: +86-755-8981 8866 Fax: +86-755-8427 6832

Email & Skype: info@chipsmall.com Web: www.chipsmall.com

Address: A1208, Overseas Decoration Building, #122 Zhenhua RD., Futian, Shenzhen, China



# 1.5A, 500kHz, 40V High Voltage Buck LED Driver

## General Description

The RT8453B is a buck current mode PWM regulator for LED driving applications. It provides an integrated 1.5A switch and can be operated with a wide input voltage range from 4.5V to 40V. With a 500kHz operating frequency, the RT8453B allows all external inductor and input/output capacitors to be small. High efficiency is achieved with its 190mV current sensing capability. Dimming can be either analog or PWM digital signal driven. The RT8453B is available in a small SOP-8 (Exposed pad) package.

## Ordering Information

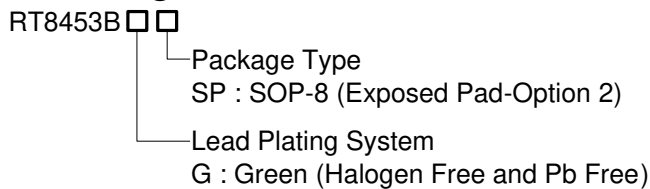

Note :

Richtek products are :

- ▶ RoHS compliant and compatible with the current requirements of IPC/JEDEC J-STD-020.
- ▶ Suitable for use in SnPb or Pb-free soldering processes.

## Marking Information

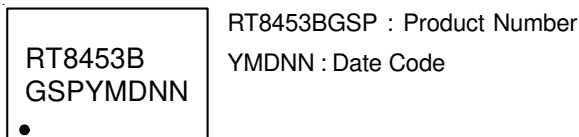

## Features

- Input Operating Range 4.5 to 40V
- 1.5A Switching Current Limitation
- 10% Constant Current Output Accuracy
- Current Mode PWM with 500kHz Switching Frequency
- Analog or PWM Control Signal for LED Dimming
- Programmable Soft-Start
- Input Under Voltage Lockout
- Over Temperature Protection
- RoHS Compliant and Halogen Free

## Applications

- General Illumination
- Desk Lights and Room Lighting
- Industrial Backlight/Lighting
- Constant Current Source

## Pin Configurations

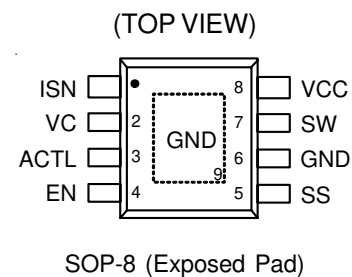

Typical Application Circuit

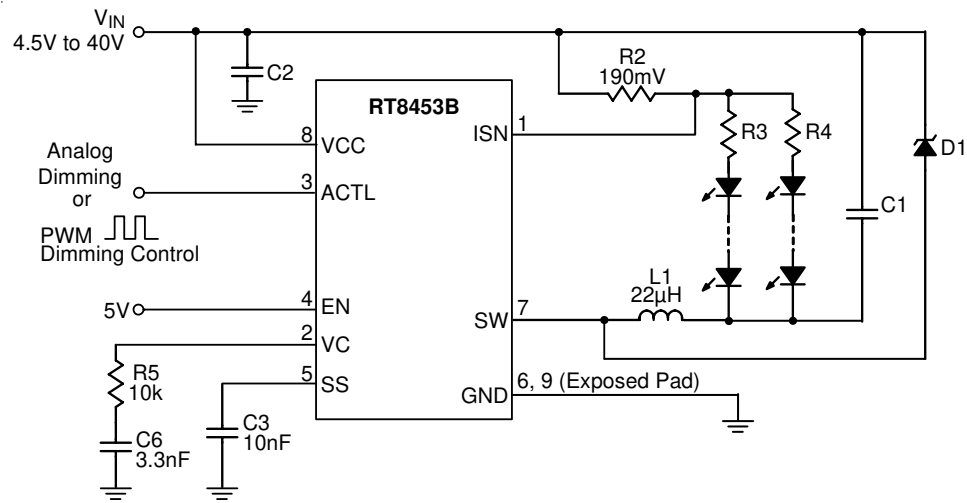

Functional Pin Description

Pin No.	Pin Name	Pin Function
1	ISN	Current Sense Amplifier Negative Input. Voltage threshold between Vcc and ISN is 190mV.
2	VC	PWM Converter Loop Compensation Node.
3	ACTL	Analog Dimming Control. Effective programming range is between 0.3V and 1.2V.
4	EN	Chip Enable (Active High). When low, chip is in shutdown mode.
5	SS	Soft-Start. A capacitor of at least 10nF is required for soft-start.
6, 9 (Exposed Pad)	GND	Ground. The exposed pad must be soldered to a large PCB and connected to GND for maximum power dissipation.
7	SW	PWM Converter Switch Node.
8	VCC	Power Supply of the Chip. For good bypass, a low ESR capacitor is required.

**Function Block Diagram**

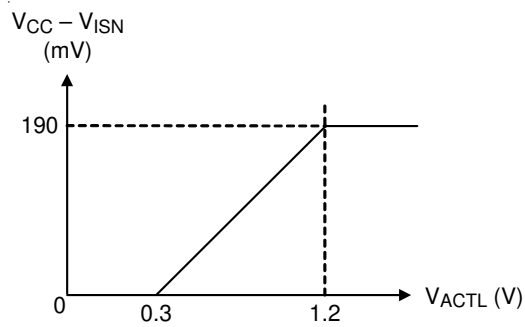
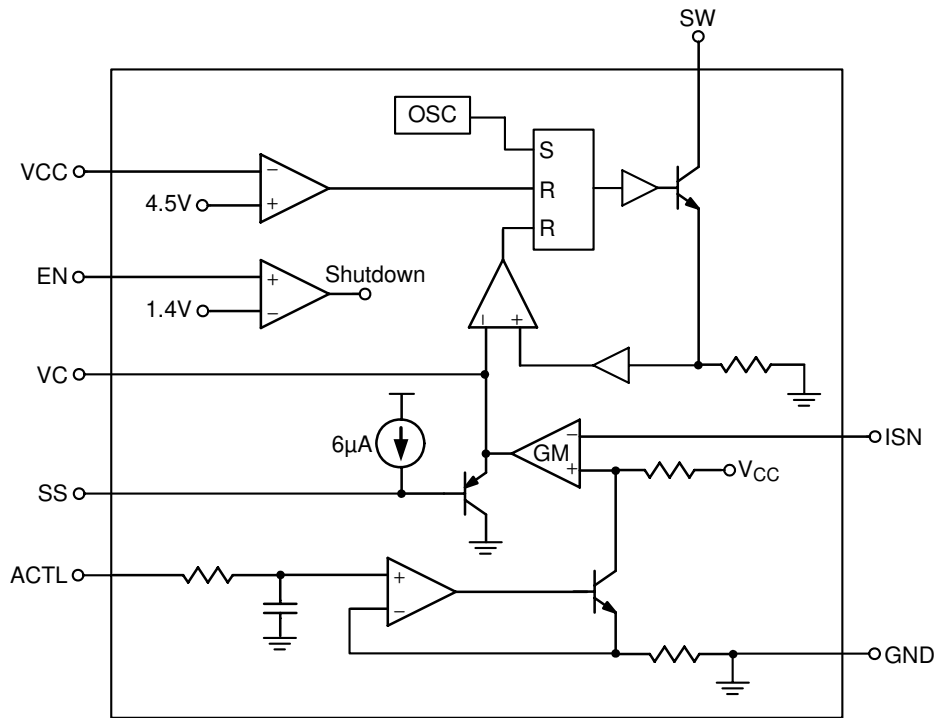

Figure 1



## Absolute Maximum Ratings (Note 1)

- Supply Input Voltage,  $V_{CC}$  ----- 45V
- SW Pin Voltage at Switching Off,  $I_{SN}$  ----- 45V
- ACTL ----- 8V (Note 2)
- EN ----- 20V
- Power Dissipation,  $P_D @ T_A = 25^\circ C$   
 SOP-8 (Exposed Pad) ----- 1.333W
- Package Thermal Resistance (Note 3)  
 SOP-8 (Exposed Pad),  $\theta_{JA}$  ----- 75°C/W  
 SOP-8 (Exposed Pad),  $\theta_{JC}$  ----- 15°C/W
- Junction Temperature ----- 150°C
- Lead Temperature (Soldering, 10 sec.) ----- 260°C
- Storage Temperature Range ----- -65°C to 150°C
- ESD Susceptibility (Note 4)  
 HBM (Human Body Mode) ----- 2kV  
 MM (Machine Mode) ----- 200V

## Recommended Operating Conditions (Note 5)

- Supply Input Voltage ----- 4.5V to 40V
- Junction Temperature Range ----- -40°C to 125°C

## Electrical Characteristics

( $V_{CC} = 12V$ , No Load,  $T_A = 25^\circ C$ , unless otherwise specified)

Parameter	Symbol	Test Conditions	Min	Typ	Max	Unit
<b>Overall</b>						
Supply Current	$I_{VCC}$	$V_C \leq 0.4V$ (Switching off)	--	4	6	mA
Shutdown Current	$I_{SHDN}$	$V_{EN} \leq 0.7V$	--	250	--	$\mu A$
EN Input Threshold Voltage	Logic-High	$V_{EN\_H}$	1.5	--	--	V
	Logic-Low	$V_{EN\_L}$	--	--	0.5	
<b>Current Sense Amplifier</b>						
Sense Threshold Voltage ( $V_{CC} - V_{ISN}$ )		$4.5V \leq \text{common mode} \leq 40V$	170	190	210	mV
ISN Pin Input Current	$I_{ISN}$	$V_{ISN} = 24V$	--	40	--	$\mu A$
VC Pin Output Current	$I_{VC}$	$2.4V > V_C > 0.2V$	--	$\pm 20$	--	$\mu A$
VC Threshold for PWM Switch Off			--	0.7	--	V
<b>LED Dimming</b>						
Analog Dimming ACTL Pin Input Current	$I_{ACTL}$	$0.3V \leq V_{ACTL} \leq 1.2V$	--	--	3	$\mu A$
LED Current Off Threshold at ACTL	$V_{ACTL}$		--	0.2	--	V
<b>PWM BOOST Converter</b>						
Switching Frequency	$f_{SW}$		400	500	600	kHz

To be continued

Parameter	Symbol	Test Conditions	Min	Typ	Max	Unit
Maximum Duty Cycle (Note 6)			--	88	--	%
SW On-Voltage	V <sub>SW</sub>	I <sub>SW</sub> = 0.5A	--	0.4	--	V
SW Current Limit	I <sub>LIM_SW</sub>		1.25	1.5	--	A
<b>Soft-Start</b>						
Soft-Start Current	I <sub>SS</sub>	V <sub>SS</sub> ≤ 2V	--	6	--	μA
<b>Over Temperature Protection</b>						
Thermal Shutdown Temperature	T <sub>SD</sub>		--	150	--	°C
Thermal Shutdown Hysteresis	ΔT <sub>SD</sub>		--	10	--	°C

**Note 1.** Stresses listed as the above "Absolute Maximum Ratings" may cause permanent damage to the device. These are for stress ratings. Functional operation of the device at these or any other conditions beyond those indicated in the operational sections of the specifications is not implied. Exposure to absolute maximum rating conditions for extended periods may remain possibility to affect device reliability.

**Note 2.** If connected with a 20kΩ series resistor, this pin can go up to 40V.

**Note 3.** θ<sub>JA</sub> is measured in natural convection at T<sub>A</sub> = 25°C on a high effective thermal conductivity four-layer test board of JEDEC 51-7 thermal measurement standard. The measurement case position of θ<sub>JC</sub> is on the exposed pad of the package.

**Note 4.** Devices are ESD sensitive. Handling precaution is recommended.

**Note 5.** The device is not guaranteed to function outside its operating conditions.

**Note 6.** When the natural maximum duty cycle of 500kHz switching frequency is reached, the switching cycle will be skipped (not reset) as the operating condition requires to effectively stretch and achieve higher on cycle.

Typical Operating Characteristics

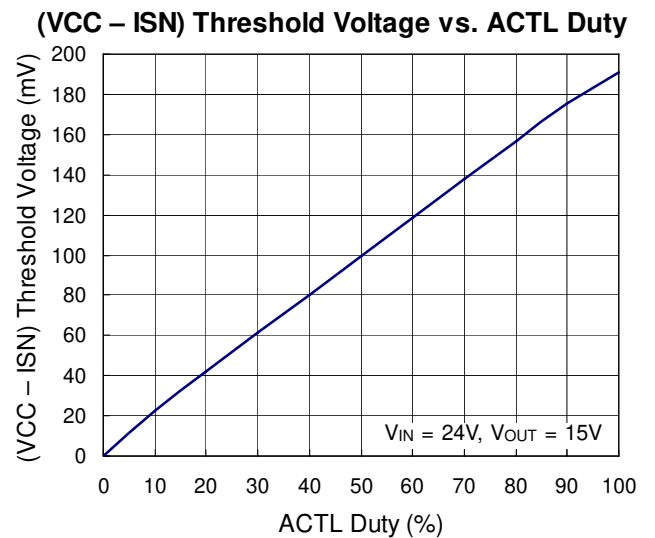
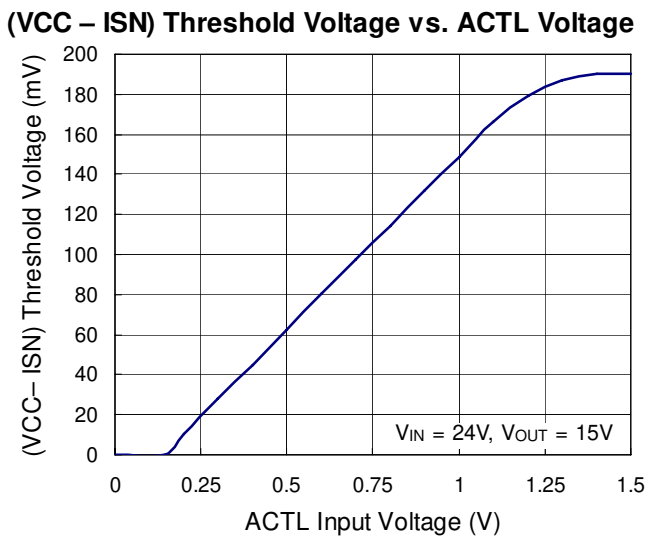
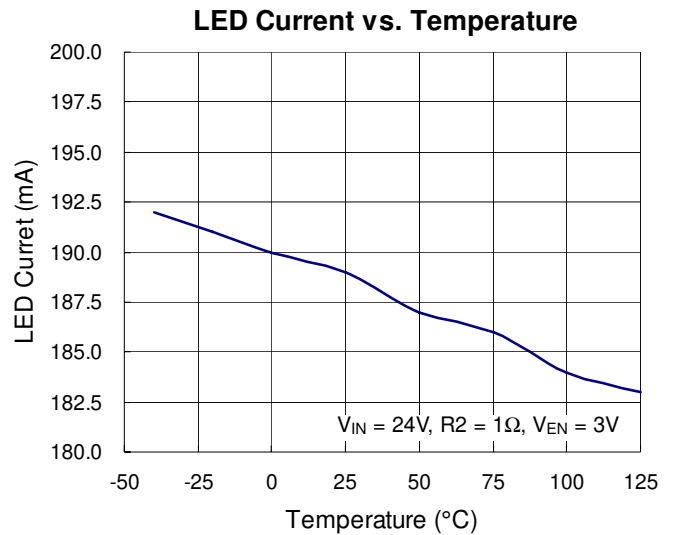
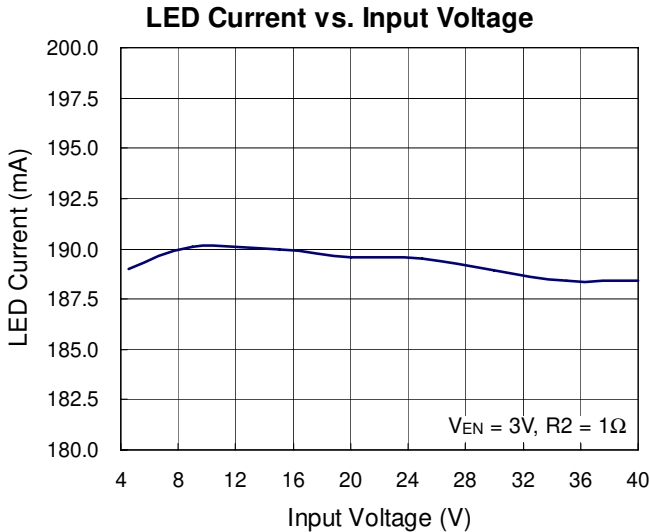
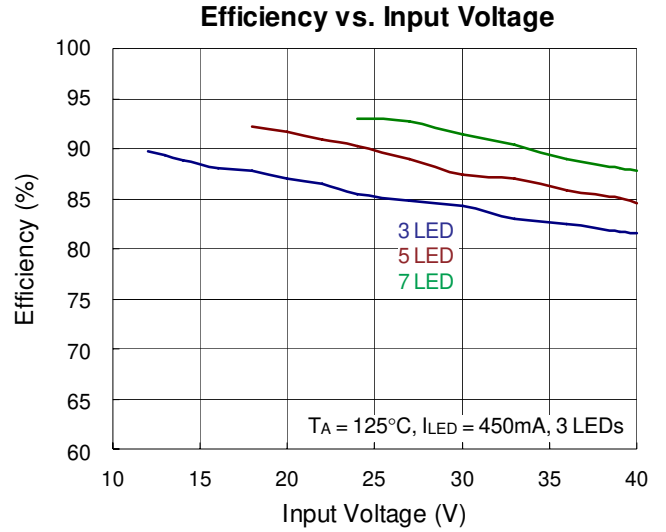
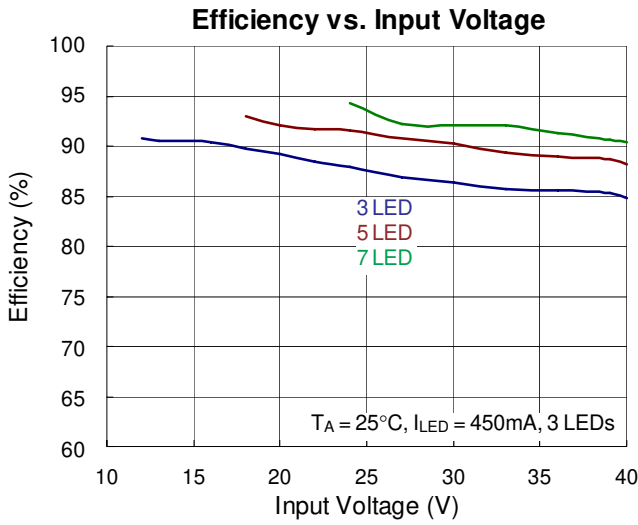

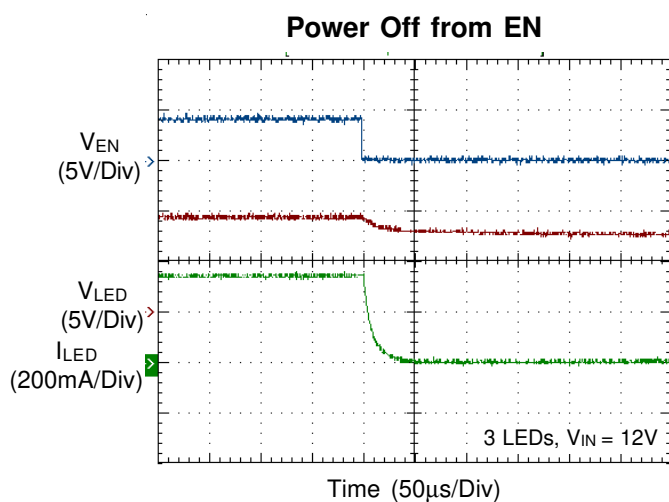
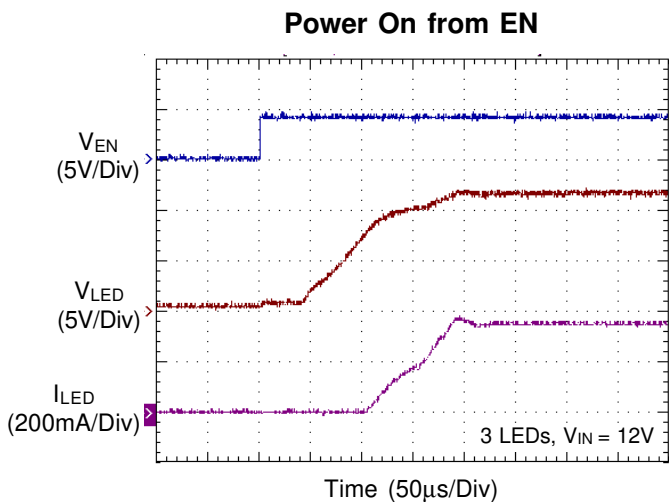
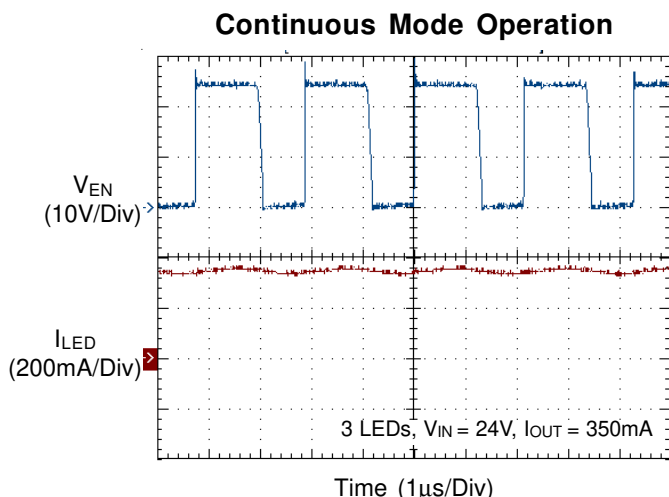
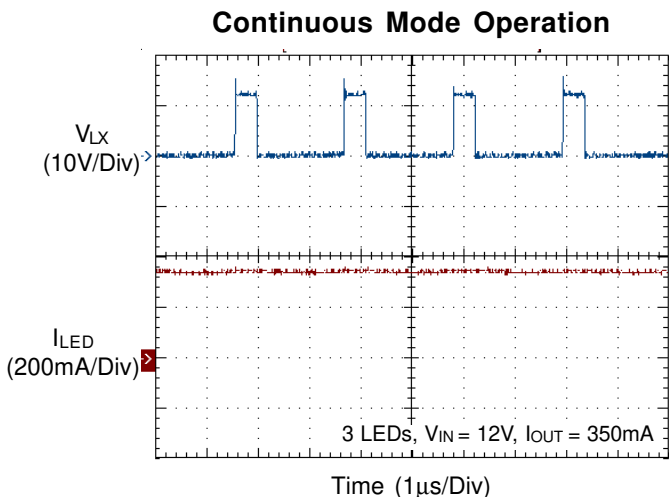
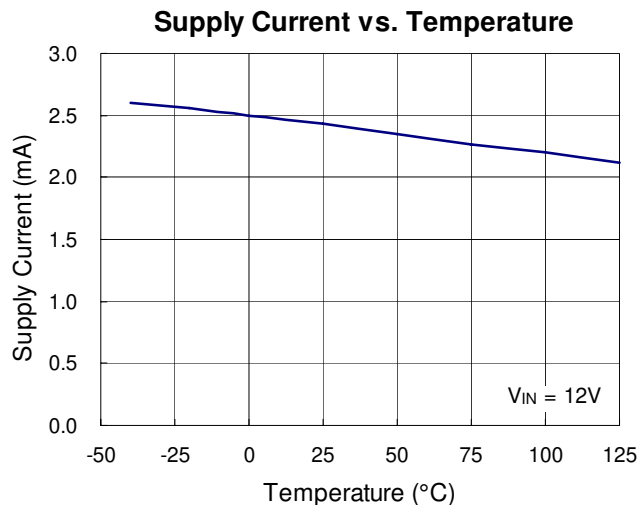
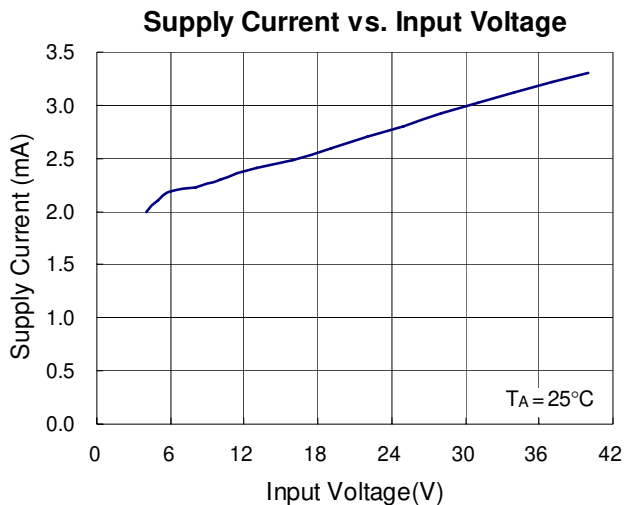



## Applications Information

The RT8453B is specifically designed to be operated in buck converter applications. This device uses a fixed frequency, current mode control scheme to provide excellent line and load regulation. The control loop has a current sense amplifier which senses the voltage between the VCC and ISN pins and provides an output voltage at the VC pin. A PWM comparator then turns off the internal power switch when the sensed power switch current exceeds the compensated VC pin voltage. The power switch will not be reset by the oscillator clock in each cycle. If the comparator does not turn off the switch in a cycle, the power switch will be on for more than a full switching period until the comparator is tripped. In this manner, the programmed voltage across the sense resistor is regulated by the control loop.

The current through the sense resistor is set by the programmed voltage and the sense resistance. The voltage across the sense resistor can be programmed by the analog or digital signal at the ACTL pin.

The protection schemes in the RT8453B include over temperature and switch current limit to prevent abnormal situations.

### Frequency Compensation

The RT8453B has an external compensation pin (VC), allowing the loop response to be optimized for specific applications. An external resistor in series with a capacitor is connected from the VC pin to GND to provide a pole and a zero for proper loop compensation. The typical value for the RT8453B is 10k and 3.3nF.

### Soft-Start

The soft-start of the RT8453B can be achieved by connecting a capacitor from the SS pin to GND.

The built in soft-start circuit reduces the start-up current spike and output voltage overshoot. The soft-start time is determined by the external capacitor which is charged by an internal 6μA constant charging current. The SS pin directly limits the rate of voltage rise on the VC pin, which in turn limits the peak switch current.

The value of the soft-start capacitor is user-defined to satisfy the designer's request.

### LED Current Setting

The LED current can be calculated by the following equation :

$$I_{LED(MAX)} = \frac{V_{CC} - V_{ISN}}{R2}$$

where  $V_{CC} - V_{ISN}$  is the voltage between VCC and ISN (190mV typ. if ACTL dimming is not applied) and the R2 is the resistor between VCC and ISN.

### Current Limit Protection

The RT8453B can limit the peak switch current with its internal over current protection feature. In normal operation, the power switch is turned off when the switch current hits the loop-set value. The over current protection function will turn off the power switch independent of the loop control when the peak switch current reaches around 1.5A.

### Over Temperature Protection

The RT8453B has an Over Temperature Protection (OTP) function to prevent over heating caused by excessive power dissipation. The OTP function will shut down switching operation when the die junction temperature exceeds 150°C . Once temperature falls below 150°C, the chip will automatically resume operation again.

### Inductor Selection

Choose an inductor that can handle the necessary peak current without saturating and ensure that the inductor has a low DCR (copper-wire resistance) to minimize  $I^2R$  power losses. A 4.7μH to 22μH inductor will meet the demand of most of the RT8453B applications.

Inductor manufacturers specify the maximum current rating as the current where the inductance falls to certain percentage of its nominal value, typically 65%.

In buck application where the transition between discontinuous and continuous modes occurs, the value of the required output inductor (L) can be approximated by the following equation :

$$L = \left[ \frac{V_{OUT}}{f \times \Delta I_L(MAX)} \right] \times \left[ 1 - \frac{V_{OUT}}{V_{IN(MAX)}} \right]$$

The ripple current  $\Delta I_L$  can be calculated :

$$\Delta I_L = \left[ \frac{V_{OUT}}{f \times L} \right] \times \left[ 1 - \frac{V_{OUT}}{V_{IN}} \right]$$

Where,

$V_{OUT}$  = output voltage.

$V_{IN}$  = input voltage.

$f$  = switching frequency.

**Schottky Diode Selection**

The Schottky diode, with their low forward voltage drop and fast switching speed, is necessary for RT8453B applications. In addition, power dissipation, reverse voltage rating and pulsating peak current are important parameters of the Schottky diode that must be considered. The diode's average current rating must exceed the average output current. The diode conducts current only when the power switch is turned off (typically less than 50% duty cycle).

**Capacitor Selection**

The input capacitor reduces current spikes from the input supply and minimizes noise injection to the converter. For most RT8453B applications, a 4.7 $\mu$ F ceramic capacitor is sufficient. A value higher or lower may be used depending on the noise level from the input supply and the input current to the converter.

In buck application, the output capacitor is typically ceramic and selection is mainly based on the output voltage ripple requirements. The output ripple,  $\Delta V_{OUT}$ , is determined by the following equation :

$$\Delta V_{OUT} \leq \Delta I_L \times \left[ ESR + \frac{1}{8 \times f \times C_{OUT}} \right]$$

**Thermal Considerations**

For continuous operation, do not exceed absolute maximum junction temperature. The maximum power dissipation depends on the thermal resistance of IC package, PCB layout, rate of surrounding airflow and temperature difference between junction to ambient. The maximum power dissipation can be calculated by following the formula :

$$P_{D(MAX)} = (T_{J(MAX)} - T_A) / \theta_{JA}$$

Where  $T_{J(MAX)}$  is the maximum junction temperature,  $T_A$  is

the ambient temperature and  $\theta_{JA}$  is the junction to ambient thermal resistance.

For recommended operating conditions specification of the RT8453B, the maximum junction temperature is 125°C and  $T_A$  is the ambient temperature. The junction to ambient thermal resistance  $\theta_{JA}$  is layout dependent. For SOP-8 (exposed pad) packages, the thermal resistance  $\theta_{JA}$  is 75°C/W on the standard JEDEC 51-7 four-layer thermal test board. The maximum power dissipation at  $T_A = 25^\circ\text{C}$  can be calculated by following formula :

$$P_{D(MAX)} = (125^\circ\text{C} - 25^\circ\text{C}) / (75^\circ\text{C/W}) = 1.333\text{W for SOP-8 (exposed pad)}$$

The maximum power dissipation depends on operating ambient temperature for fixed  $T_{J(MAX)}$  and thermal resistance  $\theta_{JA}$ . For RT8453B packages, the Figure 2 allows the designer to see the effect of rising ambient temperature on the maximum power dissipation allowed.

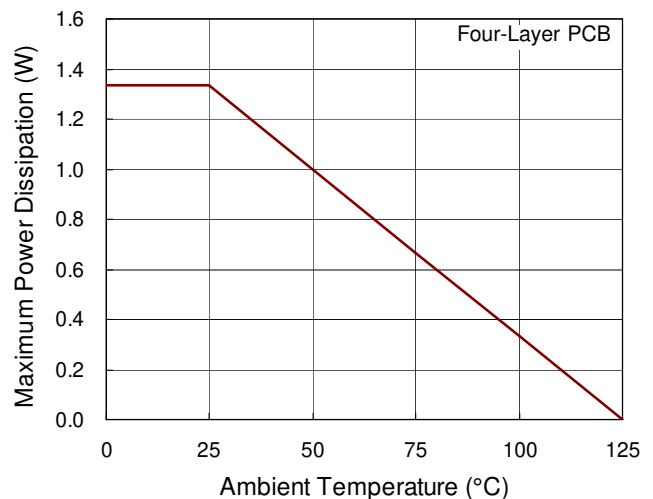

Figure 2. Derating Curve for RT8453B Package

**Layout Considerations**

PCB layout is very important when designing power switching converter circuits. Some recommended layout guide lines are as follows :

- ▶ The power components L1, D1 and C1 must be placed as close to each other as possible to reduce the ac current loop area. The PCB trace between power components must be as short and wide as possible due to large current flow through these traces during operation.

- ▶ Place L1 and D1 as close to each other as possible. The trace should be as short and wide as possible.
- ▶ The input capacitor C1 must be placed as close to VCC pin as possible.
- ▶ Place the compensation components to VC pin as close as possible to avoid noise pick up.

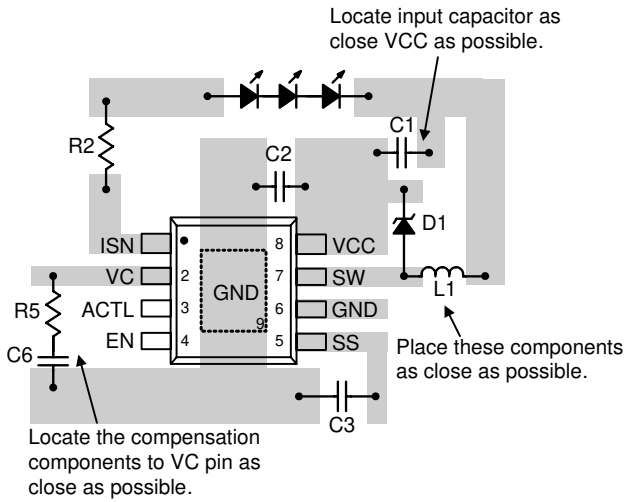
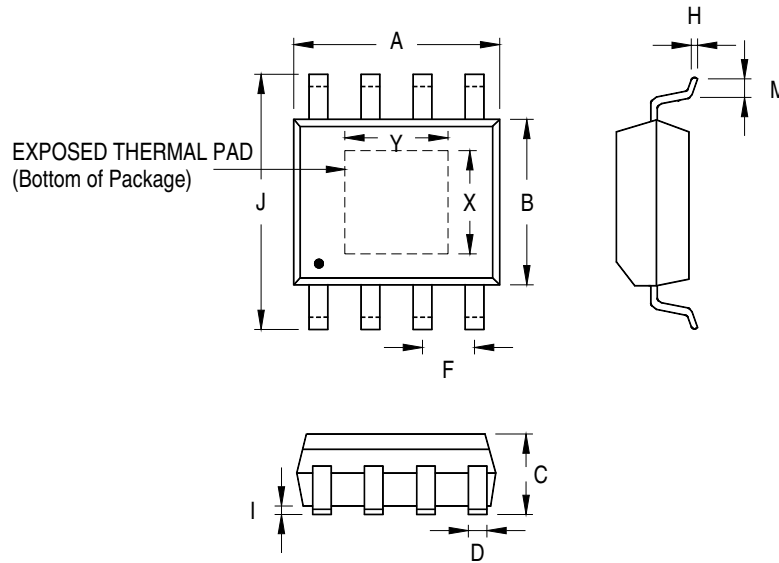

Figure 3. PCB Layout Guide

**Outline Dimension**



Symbol	Dimensions In Millimeters		Dimensions In Inches		
	Min	Max	Min	Max	
A	4.801	5.004	0.189	0.197	
B	3.810	4.000	0.150	0.157	
C	1.346	1.753	0.053	0.069	
D	0.330	0.510	0.013	0.020	
F	1.194	1.346	0.047	0.053	
H	0.170	0.254	0.007	0.010	
I	0.000	0.152	0.000	0.006	
J	5.791	6.200	0.228	0.244	
M	0.406	1.270	0.016	0.050	
Option 1	X	2.000	2.300	0.079	0.091
	Y	2.000	2.300	0.079	0.091
Option 2	X	2.100	2.500	0.083	0.098
	Y	3.000	3.500	0.118	0.138

**8-Lead SOP (Exposed Pad) Plastic Package**

**Richtek Technology Corporation**

Headquarter  
 5F, No. 20, Taiyuen Street, Chupei City  
 Hsinchu, Taiwan, R.O.C.  
 Tel: (8863)5526789 Fax: (8863)5526611

**Richtek Technology Corporation**

Taipei Office (Marketing)  
 5F, No. 95, Minchiuan Road, Hsintien City  
 Taipei County, Taiwan, R.O.C.  
 Tel: (8862)86672399 Fax: (8862)86672377  
 Email: marketing@richtek.com

Information that is provided by Richtek Technology Corporation is believed to be accurate and reliable. Richtek reserves the right to make any change in circuit design, specification or other related things if necessary without notice at any time. No third party intellectual property infringement of the applications should be guaranteed by users when integrating Richtek products into any application. No legal responsibility for any said applications is assumed by Richtek.