



Chipsmall Limited consists of a professional team with an average of over 10 year of expertise in the distribution of electronic components. Based in Hongkong, we have already established firm and mutual-benefit business relationships with customers from,Europe,America and south Asia,supplying obsolete and hard-to-find components to meet their specific needs.

With the principle of “Quality Parts,Customers Priority,Honest Operation,and Considerate Service”,our business mainly focus on the distribution of electronic components. Line cards we deal with include Microchip,ALPS,ROHM,Xilinx,Pulse,ON,Everlight and Freescale. Main products comprise IC,Modules,Potentiometer,IC Socket,Relay,Connector.Our parts cover such applications as commercial,industrial, and automotives areas.

We are looking forward to setting up business relationship with you and hope to provide you with the best service and solution. Let us make a better world for our industry!



Contact us

Tel: +86-755-8981 8866 Fax: +86-755-8427 6832

Email & Skype: info@chipsmall.com Web: www.chipsmall.com

Address: A1208, Overseas Decoration Building, #122 Zhenhua RD., Futian, Shenzhen, China



High Voltage, High Efficiency, Constant Current PWM Buck Controller for LED Lighting

General Description

The RT8458D is a PWM controller with an internal high side gate driver. Because of the Buck topology, the input voltage for the Buck system is only limited by the voltage rating of the external MOSFET. It is used for step down converters by well controlling the external MOSFET and regulating a constant output current. The output duty cycle of the RT8458D can be up to 100% for wider input voltage application.

The RT8458D also features a 160kHz fixed frequency oscillator, an internal -220mV precision reference, and a PWM comparator with latching logic. The accurate output LED current is achieved by an averaging current feedback loop and the LED current dimming can be easily controlled via the ACTL pin. The RT8458D also has multiple features to protect the controller from fault conditions, including Under Voltage Lockout (UVLO), Over Current Protection (OCP) and Over Voltage Protection (OVP). Additionally, to ensure the system reliability, the RT8458D is built with the thermal protection function.

The RT8458D is housed in a TSOT-23-6 package. Thus, the components in the whole LED driver system can be made very compact.

Features

- Low Cost and Efficient Buck Converter Solution
- Input Voltage Depends On External MOSFET
- Programmable Constant LED Current
- Dimmable LED Current by ACTL
- 100% Maximum Duty Cycle
- 160kHz Fixed Switching Frequency
- Output LED String Open Protection
- Output LED String Short Protection
- Output LED String Over Current Protection
- Built-in Thermal Protection
- TSOT-23-6 Package
- RoHS Compliant and Halogen Free

Applications

- E27, PAR30, Offline LED Lights

Marking Information

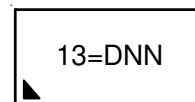

13= : Product Code
DNN : Date Code

Simplified Application Circuit

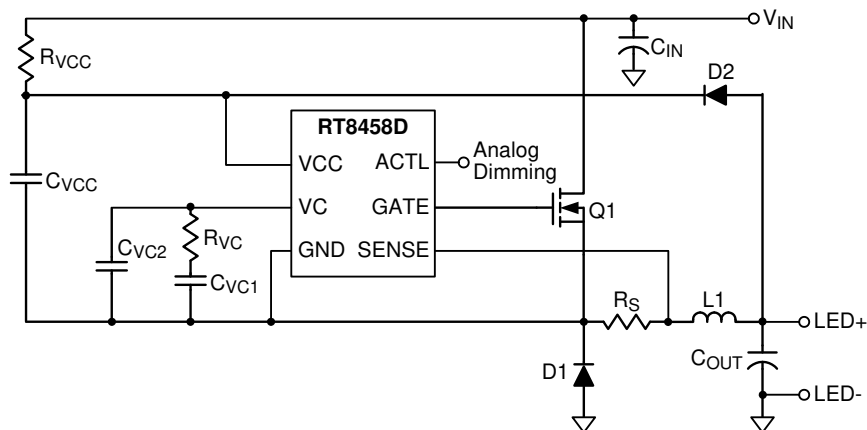

Ordering Information

RT8458D□□

- Package Type
J6 : TSOT-23-6
- Lead Plating System
G : Green (Halogen Free and Pb Free)

Note :

Richtek products are :

- ▶ RoHS compliant and compatible with the current requirements of IPC/JEDEC J-STD-020.
- ▶ Suitable for use in SnPb or Pb-free soldering processes.

Pin Configurations

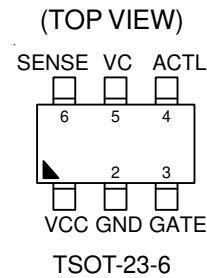

Functional Pin Description

Pin No.	Pin Name	Pin Function
1	VCC	Supply Voltage Input of the chip. For good bypass, a ceramic capacitor near the VCC pin is required.
2	GND	Ground of the Chip.
3	GATE	Gate Driver Output for External MOSFET Switch.
4	ACTL	Analog Dimming Control Input. The effective dimming range is between 0.1V to 1.2V. If V _{ACTL} is greater than 1.2V, the ACTL dimming signal high is internally clamped around 1.3V, If dimming is not used, a pull up resistor or a voltage holding capacitor between ACTL and GND pins should be used.
5	VC	PWM Loop Compensation Node.
6	SENSE	LED Current Sense Input. The typical sensing threshold is -220mV between the SENSE and GND pin.

Function Block Diagram

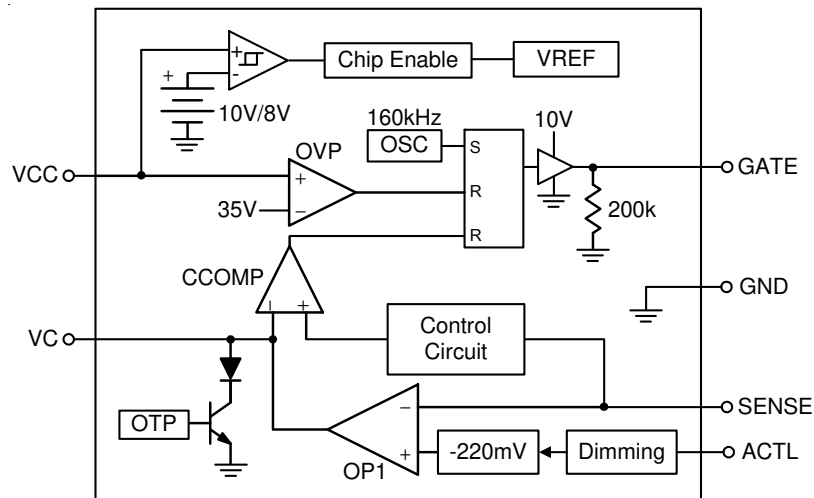

Operation

The RT8458D is a PWM Buck current mode controller with an integrated high side gate driver. The start-up voltage of RT8458D is around 10V. Once VCC is above the start-up voltage, the RT8458D will maintain operation until VCC drops below 8V.

The RT8458D's main control loop consists of a 160kHz fixed frequency oscillator, an internal -220mV precision current sense threshold OPAMP (OP1), and a PWM comparator (CCOMP) with latching logic. In normal operation, the GATE turns high when the gate driver is set by the oscillator (OSC). The lower the average of the sensed current is below the loop-regulated -220mV threshold, the higher the VC pin voltage (OP1 output) will go high. Higher the VC voltage means longer the GATE turn-on period. The GATE of RT8458D can turn on up to 100% duty. The GATE turns low until the current comparator (CCOMP) resets the gate driver. The GATE will be set high again by OSC and the next switching cycle repeats.

The adjustment of the regulated sense current threshold (dimming) can be achieved by varying ACTL pin voltage. The typical range of ACTL voltage adjustment is between 0.1V and 1.2V.

The RT8458D is equipped with protection from several fault conditions, including input voltage Under Voltage Lockout (UVLO), Over Current Protection (OCP) and VIN/VOUT Over Voltage Protection (OVP). Additionally, to ensure the system reliability, the RT8458D is built with internal thermal protection function.

Absolute Maximum Ratings (Note 1)

- Supply Input Voltage, VCC ----- -0.3V to 40V
- GATE Voltage (Note 8) ----- -0.3V to 16V
- ACTL Voltage (Note 6) ----- -0.3V to 8V
- VC Voltage ----- -0.3V to 6V
- SENSE Voltage ----- -1V to 0.3V
- Power Dissipation, P_D @ T_A = 25°C
 - TSOT-23-6 ----- 0.392W
- Package Thermal Resistance (Note 2)
 - TSOT-23-6, θ_{JA} ----- 255°C/W
 - TSOT-23-6, θ_{JC} ----- 135°C/W
- Junction Temperature ----- 150°C
- Lead Temperature (Soldering, 10 sec.) ----- 260°C
- Storage Temperature Range ----- -65°C to 150°C
- ESD Susceptibility (Note 3)
 - HBM (Human Body Model) ----- 2kV
 - MM (Machine Model) ----- 200V

Recommended Operating Conditions (Note 4)

- Supply Input Voltage, VCC ----- 10V to 31V
- Junction Temperature Range ----- -40°C to 125°C

Electrical Characteristics

(V_{CC} = 24V, T_A = 25°C, unless otherwise specified)

Parameter	Symbol	Test Conditions	Min	Typ	Max	Unit
Input Start-Up Voltage	V _{CC_ST}		--	10	12	V
Minimum Operation Voltage After Start-Up	V _{CC(MIN)}		--	8	9	V
Maximum Startup Current in VCC Hiccup Operation	I _{ST(MAX)}	Maximum I _{CC} to cause V _{CC} stop hiccup at low end of V _{CC} hysteresis level	--	250	300	μA
Input Supply Current	I _{CC}	After Start-Up, V _{CC} = 24V	--	2	5	mA
Input Shutdown Current	I _{QC}	Before Start-Up, V _{CC} = 5V	--	1	5	μA
Oscillator						
Switching Frequency	f _{sw}		120	160	200	kHz
Maximum Duty in Transient Operation	D _{MAX(TR)}	V _C = 3V	--	--	100	%
Maximum Duty in Steady State Operation	D _{MAX}		--	88	--	%
Blanking Time	t _{BLANK}	(Note 7)	--	300	--	ns
Minimum Off Time	t _{off(MIN)}	(Note 7)	--	600	--	ns

Parameter	Symbol	Test Conditions	Min	Typ	Max	Unit
Current Sense Amplifier						
Current Sense Voltage	V _{SENSE}	(Note 5)	-213	-220	-227	mV
Sense Input Current	I _{SENSE}	(Note 7)	--	11	--	μA
VC Sourcing Current	I _{VC_Source}	V _{SENSE} = -150mV (Note 7)	--	20	--	μA
VC Sinking Current	I _{VC_Sink}	V _{SENSE} = -250mV (Note 7)	--	180	--	μA
VC Threshold for PWM Switch Off	V _{VC}		1.15	1.25	1.35	V
GATE Driver Output						
GATE Pin Maximum Voltage	V _{GATE}	No Load at GATE Pin	--	10	16	V
GATE Voltage High	V _{GATE_H}	I _{GATE} = -50mA	8	9.7	11.5	V
		I _{GATE} = -100μA	8.5	10	12	
GATE Voltage Low	V _{GATE_L}	I _{GATE} = 50mA	0.01	0.75	1.2	V
		I _{GATE} = 100μA	0.01	0.5	1.2	
GATE Drive Rise Time		1nF Load at GATE	--	60	150	ns
GATE Driver Fall Time		1nF Load at GATE	--	30	100	ns
GATE Drive Source Peak Current		1nF Load at GATE	--	0.2	0.5	A
GATE Driver Sink Peak Current		1nF Load at GATE	--	0.5	0.8	A
LED Dimming						
Analog Dimming ACTL Pin Input Current	I _{ACTL}	V _{ACTL} = 1.2V	--	1	5	μA
LED Current On Threshold at ACTL	V _{ACTL_On}		--	1.2	1.3	V
LED Current Off Threshold at ACTL	V _{ACTL_Off}		--	0.1	0.2	V
OVP						
Over Voltage Protection	V _{OVP}	VCC Pin	32	35	38	V
Thermal Protection						
Thermal Shutdown Temperature	T _{SD}		--	150	--	°C

Note 1. Stresses beyond those listed “Absolute Maximum Ratings” may cause permanent damage to the device. These are stress ratings only, and functional operation of the device at these or any other conditions beyond those indicated in the operational sections of the specifications is not implied. Exposure to absolute maximum rating conditions may affect device reliability.

Note 2. θ_{JA} is measured at T_A = 25°C on a low effective thermal conductivity single-layer test board per JEDEC 51-3. θ_{JC} is measured at the exposed pad of the package.

Note 3. Devices are ESD sensitive. Handling precaution is recommended.

Note 4. The device is not guaranteed to function outside its operating conditions.

Note 5. The RT8458D achieves precise LED average current with a current feedback loop to sense the average LED current, in the deep discontinuous mode operation especially when a small inductor is used, small current offset might occur due to current waveform distortion of the nature of the discontinuous operation. This offset current is consistent over production.

Note 6. If a 1MΩ resistor is connected between the control input and ACTL pin, the control input voltage can be up to 36V.

Note 7. Guaranteed by design, not subjected to production test.

Note 8. The GATE voltage is internally clamped and varies with operating conditions.

Typical Application Circuit

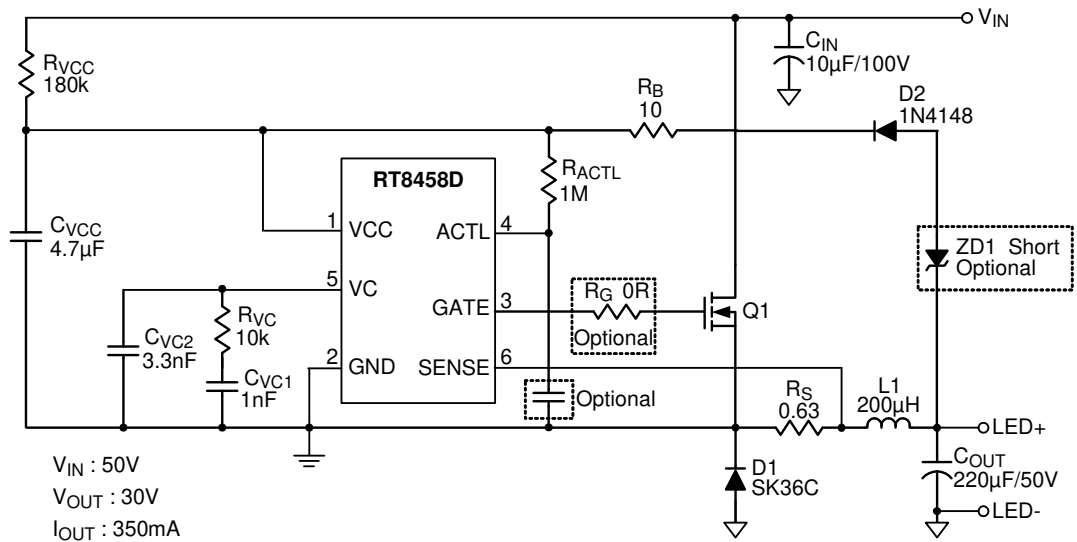

Typical Operating Characteristics

Efficiency vs. Input Voltage

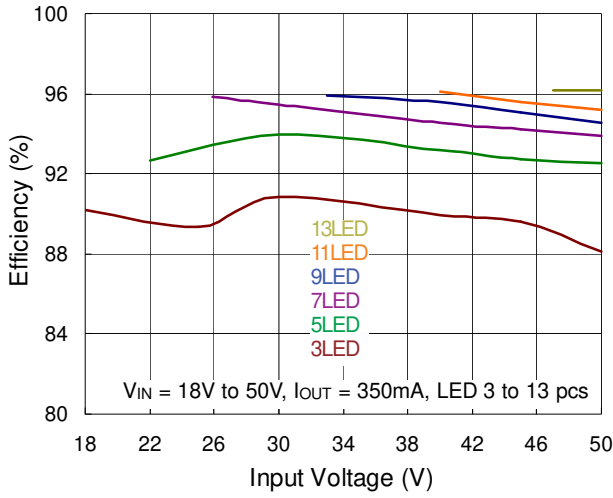

Output Current vs. Input Voltage

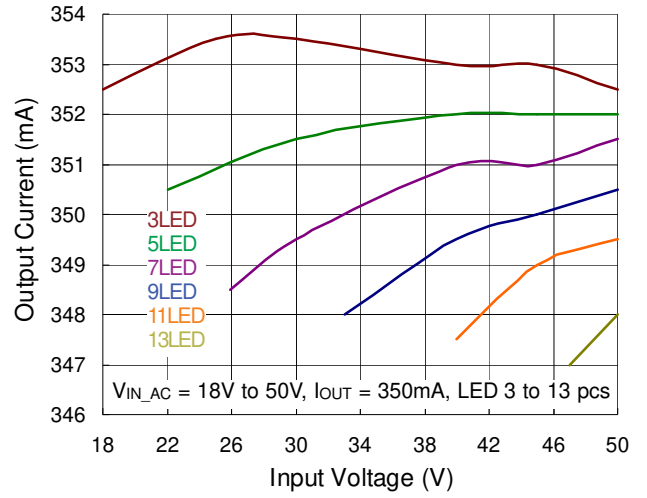

Switching Frequency vs. Supply Voltage

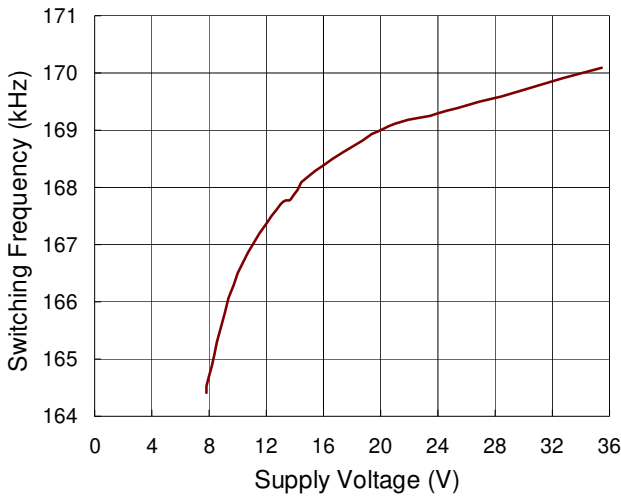

Switching Frequency vs. Temperature

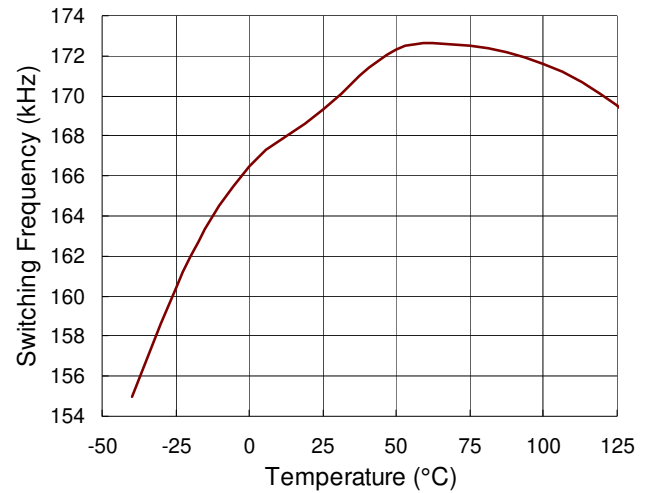

SENSE Threshold vs. Supply Voltage

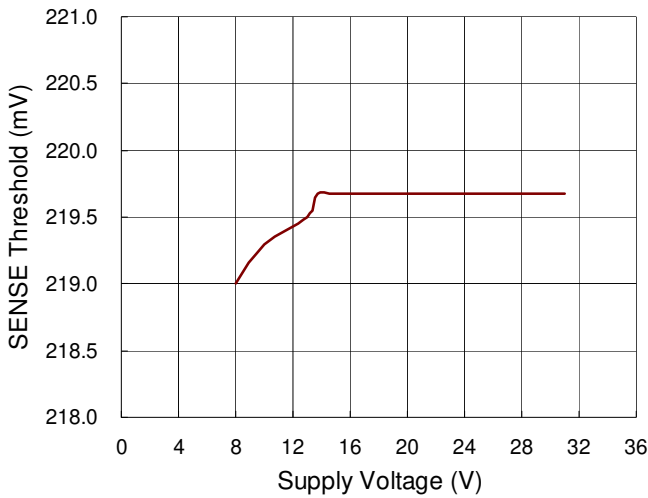

SENSE Threshold vs. Temperature

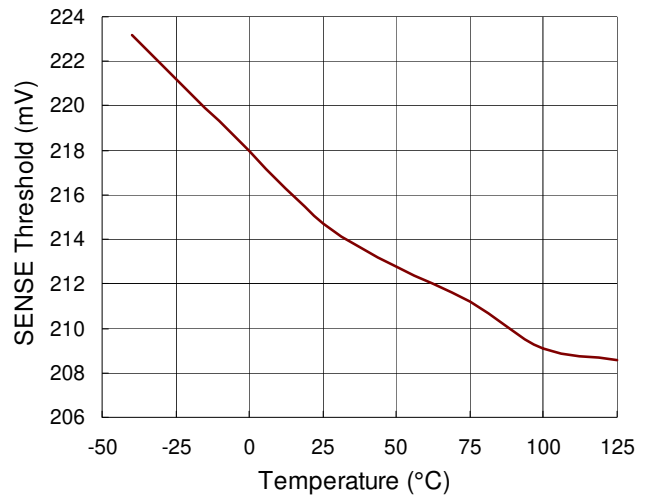

SENSE Threshold vs. ACTL Voltage

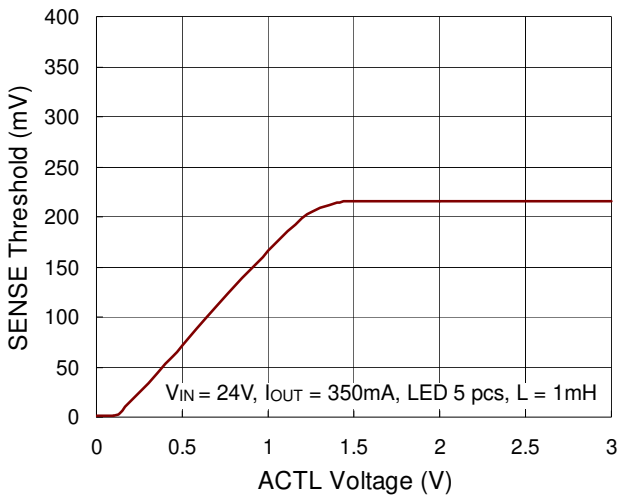

Output Current vs. Output Voltage

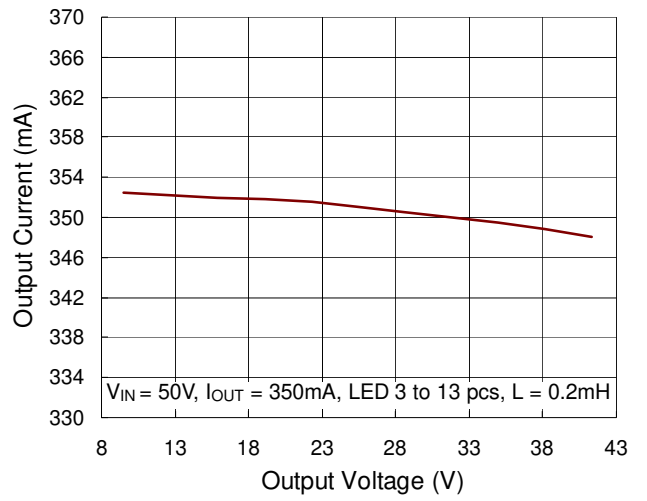

Power On

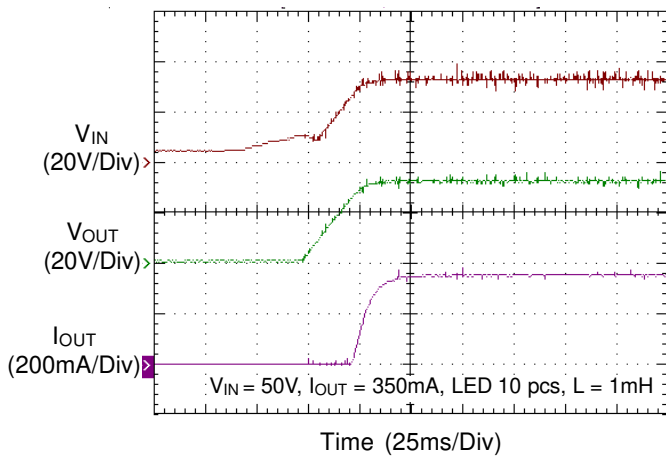

Power Off

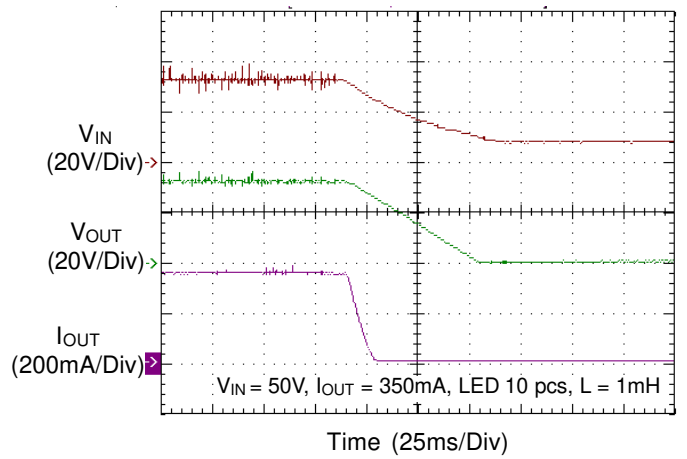

Application Information

The RT8458D is a high efficiency PWM Buck LED controller for high brightness LED application. Its high side gate driver is used to control the Buck converter via an external MOSFET and regulate the constant output current.

The RT8458D can achieve high accurate LED output current via the average current feedback loop control. The internal sense voltage (–220mV typ.) is used to set the average output current. The oscillator's frequency is fixed at 160kHz to get better switching performance. Once the average current is set by the external resistor, R_S , the output LED current can be dimmed by varying the ACTL voltage.

Under Voltage Lockout (UVLO)

The RT8458D includes a UVLO feature with 2V hysteresis. The GATE terminal turns on when V_{IN} rises over 10V (typ.). The GATE terminal turns off when V_{IN} falls below 8V (typ.).

Setting Average Output Current

The output current that flows through the LED string is set by an external resistor, R_S , which is connected between the GND and SENSE pins. With ACTL pin voltage greater than 1.2V, the relationship between output current, I_{OUT} , and R_S is shown below :

$$I_{OUT} = \frac{0.22}{R_S} \text{ (A)}$$

Analog Dimming Control

The ACTL terminal is driven by an external voltage, V_{ACTL} , to adjust the output current to an average value set by R_S . The voltage range for V_{ACTL} to adjust the output current is from 0.1V to 1.2V. For V_{ACTL} between 0.1V to 1.2V, the output current value will be determined by the following formula :

$$I_{OUTavg} = (0.22V / R_S) \times \frac{V_{ACTL} - 0.1}{1.1}$$

Start-Up Resistor

Start-up resistor should be chosen not to exceed the maximum start-up current. Otherwise, the RT8458D may latch low and will never start. The maximum start-up current is V_{IN} / R_{VCC} .

VCC Supplied from Auxiliary Winding

Auxiliary winding can be added to the main step-down converter with coupled inductor. Because the diode voltage drop and the RT8458D controller regulate the output current, the inductor's voltage drop is also relatively constant during the OFF time. To remain output average current, the main inductor should be in continuous current conduction throughout the step-down load range.

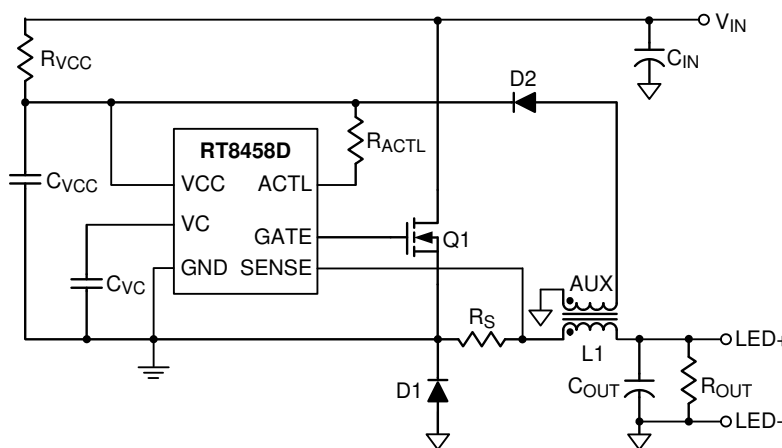

Figure 1. V_{CC} Supplied from Auxiliary Winding

Three functions are needed to set the value of the main inductor : the voltage across the inductor, the operating frequency, and the inductor's current ripple. These functions will ensure that adequate energy is stored in the inductor together. The Auxiliary output voltage V_{AUX} to VCC is given by :

$$V_{AUX} = N_2 / N_1 (V_{OUT} + V_{D1}) - V_{D2}$$

N_1 = primary turns and N_2 = secondary turns.

The V_{AUX} design value should be set below 31V for RT8458D OVP limitation in normal operation. This output in Figure 1 is independent of input voltage changes, as D_2 is ON when the MOSFET OFF. For a given inductor value, secondary power at the auxiliary output is limited by the onset of discontinuous current in the main primary loop.

To use Auxiliary output to supply the VCC, the Minimum load is required to place a resistor as load at the output.

If $V_{IN} >$ output LED forward voltage, the leakage current (~2mA) which is RT8458D operating Current will pass through the output LED. This leakage current will light on the output LED. To avoid this leakage current pass through LED, place a resistor between LED+ and LED-. The resistor value is $(V_{OUT} / 2mA)$ and the consume power is about $(V_{OUT} \times 2mA)$.

Input Capacitor Selection

The input capacitor supplies the peak current to the inductor and flattens the current ripple on the input. The low ESR condition is required to avoid increasing power loss. The ceramic capacitor is recommended due to its excellent high frequency characteristic and low ESR. For maximum stability over the entire operating temperature range, capacitors with better dielectric are suggested.

For most of the RT8458D applications, a 10 μ F ceramic capacitor is sufficient. Use of X7R type ceramic capacitors is recommended. Lower operating frequencies will require proportionately higher capacitor values.

Thus, a 10 μ F / 100V electrolytic capacitor can be chosen in this case due to its low ESR.

Inductor Selection

The inductor value and operating frequency determine the ripple current according to a specific input and output voltage. The ripple current, ΔI_L , increases with higher V_{IN} and decreases with higher inductance, as shown in equation below :

$$\Delta I_L = \left[\frac{V_{OUT}}{f \times L} \right] \times \left[1 - \frac{V_{OUT}}{V_{IN}} \right]$$

To optimize the ripple current, the RT8458D operates the Buck converter in BCM (Boundary-Condition Mode). The largest ripple current will occur at the highest V_{IN} . To guarantee that the ripple current stays below the specified value, the inductor value should be chosen according to the following equation :

$$L = \frac{V_{OUT} \times T_S \times (1-D)}{2 \times I_{OUT}}$$

where D is the duty cycle and T_S is the switching period.

Forward Diode Selection

The Schottky diode, with their low forward voltage drop and fast switching speed, is necessary for the RT8458D applications. In addition, power dissipation, reverse voltage rating and pulsating peak current are also important parameters for the Schottky diode selection. Choose a suitable Schottky diode with reverse voltage rating greater than the maximum output voltage. The diode's average current rating must exceed the average output current. The diode conducts current only when the power switch is turned off (typically less than 50% duty cycle). If using the PWM feature for dimming, it is important to consider diode leakage, which increases with temperature, from the output during the PWM low interval. Therefore, a Schottky diode with sufficiently low leakage current is suggested.

MOSFET Selection

For applications operating at high input or output voltages, the power N-MOSFET switch is typically chosen for drain voltage, V_{DS} , rating and low gate charge. Consideration of switch on-resistance, $R_{DS(ON)}$, is usually secondary because switching losses dominate power loss.

Output Capacitor Selection

The selection of C_{OUT} is determined by the required ESR to minimize output voltage ripple. Moreover, the amount of bulk capacitance is also a key for C_{OUT} selection to ensure that the control loop is stable. Loop stability can be checked by viewing the load transient response. The output voltage ripple, ΔV_{OUT}, is determined by :

$$\Delta V_{OUT} \leq \Delta I_L \left[ESR + \frac{1}{8f_{OSC}C_{OUT}} \right]$$

where f_{OSC} is the switching frequency and ΔI_L is the inductor ripple current. The output voltage ripple will be the highest at the maximum input voltage since ΔI_L increases with input voltage. Multiple capacitors placed in parallel may be needed to meet the ESR and RMS current handling requirement. Dry tantalum, special polymer, aluminum electrolytic and ceramic capacitors are all common selections and available in surface mount packages. Tantalum capacitors have the highest capacitance density, but it is important to only use ones that pass the surge test for use in switching power supplies. Special polymer capacitors offer very low ESR value, but with the trade-off of lower capacitance density. Aluminum electrolytic capacitors have significantly higher ESR, but still can be used in cost-sensitive applications for ripple current rating and long term reliability considerations.

Thermal Protection

A thermal protection feature is included to protect the RT8458D from excessive heat damage. When the junction temperature exceeds a threshold of 150°C, the thermal protection will turn off the GATE terminal.

Soldering Process of Pb-free Package Plating

To meet the current RoHS requirements, pure tin is selected to provide forward and backward compatibility with both the current industry standard SnPb-based soldering processes and higher temperature Pb-free processes. In the whole Pb-free soldering processes, pure tin is required with a maximum 260°C (<10s) for proper soldering on board, referring to J-STD-020 for more information.

Thermal Considerations

For continuous operation, do not exceed absolute maximum junction temperature. The maximum power dissipation depends on the thermal resistance of the IC package, PCB layout, rate of surrounding airflow, and difference between junction and ambient temperature. The maximum power dissipation can be calculated by the following formula :

$$P_{D(MAX)} = (T_{J(MAX)} - T_A) / \theta_{JA}$$

where T_{J(MAX)} is the maximum junction temperature, T_A is the ambient temperature, and θ_{JA} is the junction to ambient thermal resistance.

For recommended operating condition specifications, the maximum junction temperature is 125°C. The junction to ambient thermal resistance, θ_{JA}, is layout dependent. For TSOT-23-6 package, the thermal resistance, θ_{JA}, is 255°C/W on a standard JEDEC 51-3 single-layer thermal test board. The maximum power dissipation at T_A = 25°C can be calculated by the following formula :

$$P_{D(MAX)} = (125^\circ\text{C} - 25^\circ\text{C}) / (255^\circ\text{C/W}) = 0.392\text{W for TSOT-23-6 package}$$

The maximum power dissipation depends on the operating ambient temperature for fixed T_{J(MAX)} and thermal resistance, θ_{JA}. The derating curve in Figure 2 allows the designer to see the effect of rising ambient temperature on the maximum power dissipation.

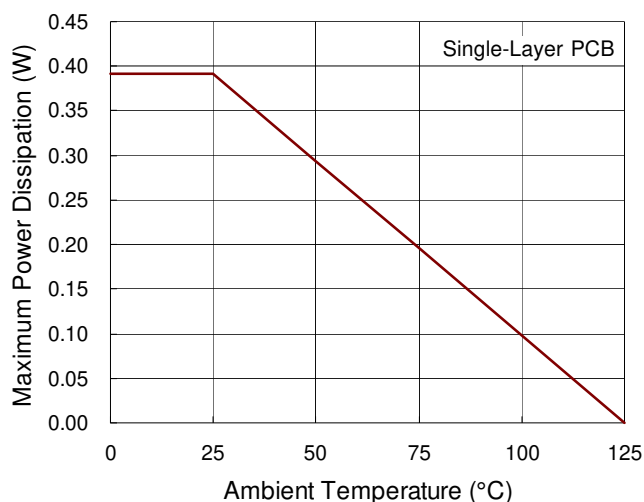

Figure 2. Derating Curve of Maximum Power Dissipation

Layout Considerations

For best performance of the RT8458D, the following layout guidelines should be strictly followed.

- ▶ The hold up capacitor, C_{VCC} , must be placed as close as possible to the VCC pin.
- ▶ The output capacitor, C_{OUT} , must be placed as close as possible to the LED terminal.
- ▶ The power GND should be connected to a strong ground plane.
- ▶ R_S should be connected between the GND pin and SENSE pin.
- ▶ Keep the main current traces as short and wide as possible.
- ▶ Place L1, Q1, R_S , and D1 as close to each other as possible.

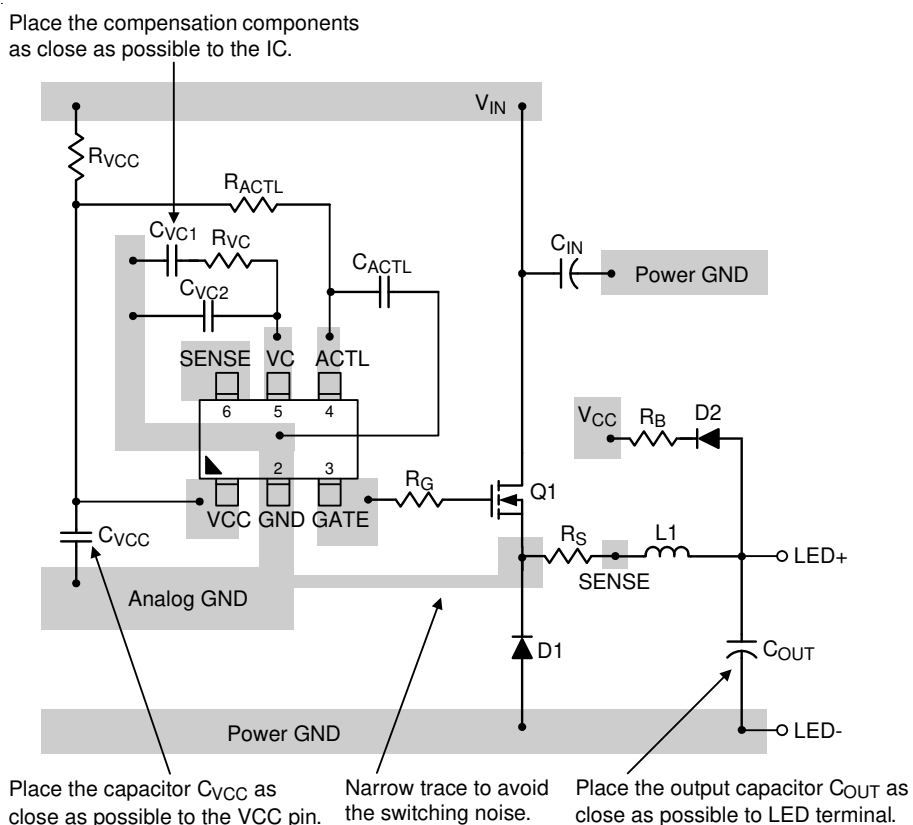
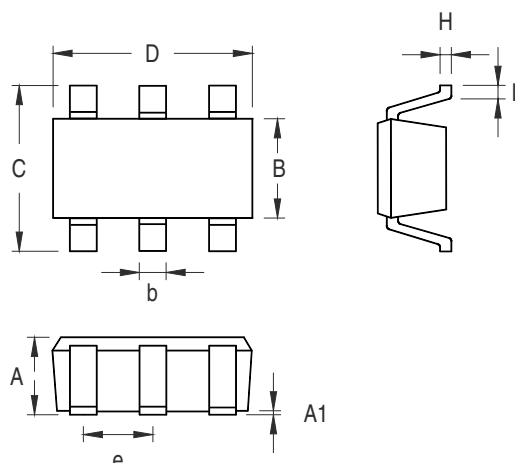

Figure 3. PCB Layout Guide

Outline Dimension



Symbol	Dimensions In Millimeters		Dimensions In Inches	
	Min	Max	Min	Max
A	0.700	1.000	0.028	0.039
A1	0.000	0.100	0.000	0.004
B	1.397	1.803	0.055	0.071
b	0.300	0.559	0.012	0.022
C	2.591	3.000	0.102	0.118
D	2.692	3.099	0.106	0.122
e	0.838	1.041	0.033	0.041
H	0.080	0.254	0.003	0.010
L	0.300	0.610	0.012	0.024

TSOT-23-6 Surface Mount Package

Richtek Technology Corporation

14F, No. 8, Tai Yuen 1st Street, Chupei City
 Hsinchu, Taiwan, R.O.C.
 Tel: (8863)5526789

Richtek products are sold by description only. Richtek reserves the right to change the circuitry and/or specifications without notice at any time. Customers should obtain the latest relevant information and data sheets before placing orders and should verify that such information is current and complete. Richtek cannot assume responsibility for use of any circuitry other than circuitry entirely embodied in a Richtek product. Information furnished by Richtek is believed to be accurate and reliable. However, no responsibility is assumed by Richtek or its subsidiaries for its use; nor for any infringements of patents or other rights of third parties which may result from its use. No license is granted by implication or otherwise under any patent or patent rights of Richtek or its subsidiaries.