



Chipsmall Limited consists of a professional team with an average of over 10 year of expertise in the distribution of electronic components. Based in Hongkong, we have already established firm and mutual-benefit business relationships with customers from,Europe,America and south Asia,supplying obsolete and hard-to-find components to meet their specific needs.

With the principle of “Quality Parts,Customers Priority,Honest Operation,and Considerate Service”,our business mainly focus on the distribution of electronic components. Line cards we deal with include Microchip,ALPS,ROHM,Xilinx,Pulse,ON,Everlight and Freescale. Main products comprise IC,Modules,Potentiometer,IC Socket,Relay,Connector.Our parts cover such applications as commercial,industrial, and automotives areas.

We are looking forward to setting up business relationship with you and hope to provide you with the best service and solution. Let us make a better world for our industry!



## Contact us

Tel: +86-755-8981 8866 Fax: +86-755-8427 6832

Email & Skype: info@chipsmall.com Web: www.chipsmall.com

Address: A1208, Overseas Decoration Building, #122 Zhenhua RD., Futian, Shenzhen, China



# Tiny Package, High Efficiency, Constant Current LED Driver

## General Description

The RT9269 is a compact, high efficient LED driver with high flexibility of application configurations in charge pump mode or in boost rectifier mode, delivering Tens of mA constant output current for driving 1~4 white LED's.

The 0.25V low reference voltage minimized the power loss across the current-setting resistor.

The wide applicable VDD range makes RT9269 suitable for 1 to 4 battery cell applications as well as being supplied with 2.5/3.3/5/6V system powers. The 500kHz high switching rate minimized the size of external components. Besides, the 17μA low quiescent current together with high efficiency maintains long battery lifetime.

The output current is set with 1 external resistor. And the chip enable (EN) pin can be used for tuning the LED brightness by controlling the ON/OFF duty with external clock. RT9269 is provided in SOT-23-6 package.

## Ordering Information

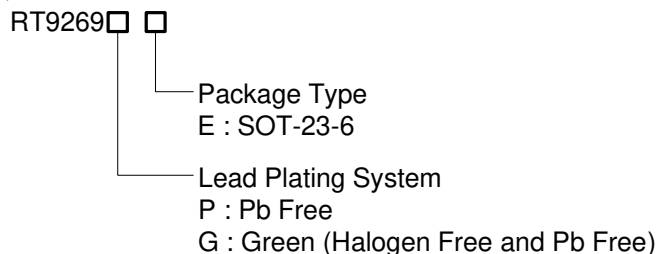

Note :

Richtek products are :

- ▶ RoHS compliant and compatible with the current requirements of IPC/JEDEC J-STD-020.
- ▶ Suitable for use in SnPb or Pb-free soldering processes.

## Marking Information

For marking information, contact our sales representative directly or through a Richtek distributor located in your area.

## Features

- 0.25V Low Reference Voltage
- 17μA Quiescent (Switch-off) Supply Current
- Zero Shutdown Mode Supply Current
- 85% Efficiency
- 500kHz Fixed Switching Rate
- Tuning LED brightness with EN Pin ON/OFF Duty
- Small SOT-23-6 Package
- RoHS Compliant and 100% Lead (Pb)-Free

## Applications

- LED Module
- Hand Held Panel
- Compact Back Light Module
- Small Battery Charger
- Constant Current Source

## Pin Configurations

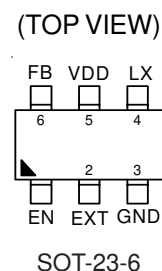

Typical Application Circuit

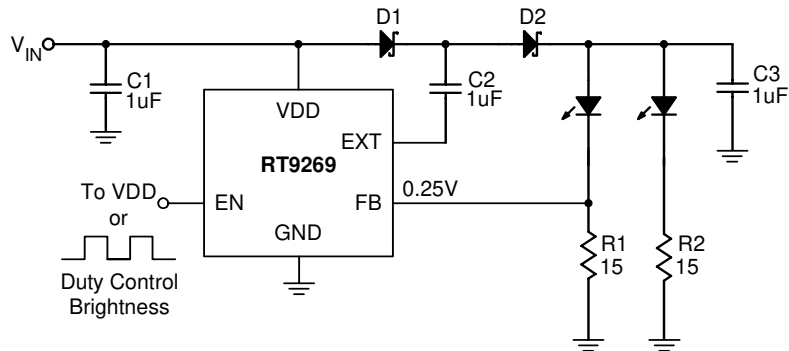

Figure 1. RT9269 drives single or parallel LED's in charge pump configuration

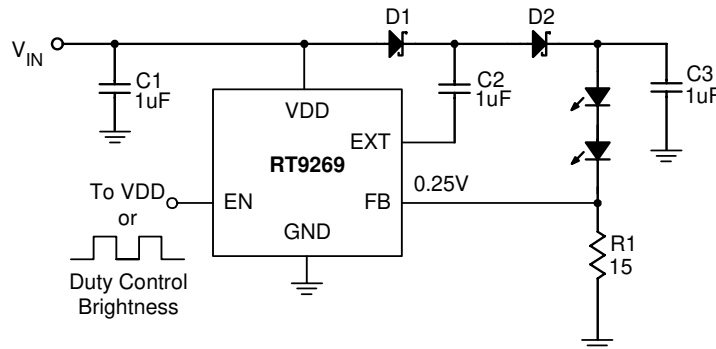

Figure 2. RT9269 drives 2 series connected LED's in charge pump configuration

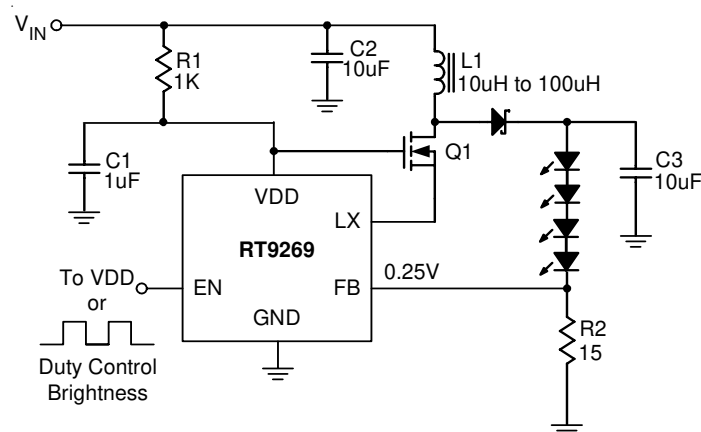

Figure 3. RT9269 drives 2~4 series connected LED's in boost rectifier configuration

Note: NICHIANSCW100 is used for RT9269 LED parts.

**Functional Pin Description**

Pin No.	Pin Name	Pin Function
1	EN	Chip Enable (Active High)
2	EXT	Output Pin for Configuring Charge Pump or Driving External NMOS
3	GND	Ground
4	LX	Pin for Switching
5	VDD	Input Positive Power Pin of RT9269
6	FB	Feedback Input pin Internal Reference Voltage for the Error Amplifier is 0.25V.

**Function Block Diagram**

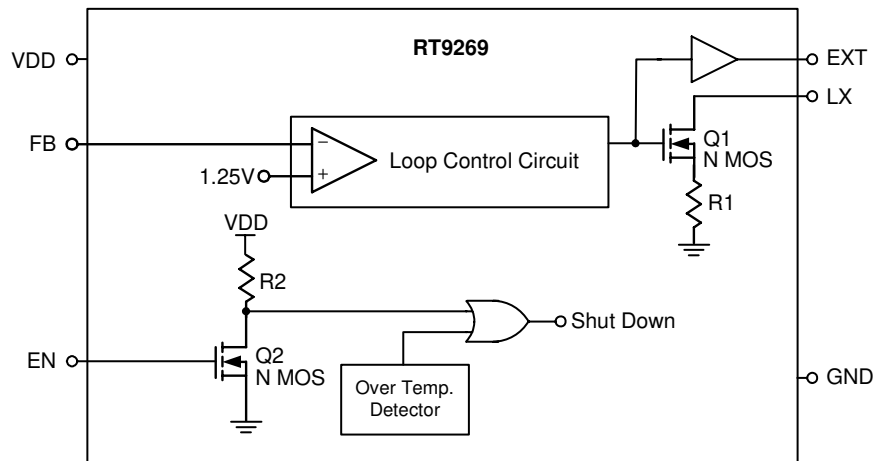

## Absolute Maximum Ratings

- Supply Voltage ----- -0.3V to 7V
- LX Pin Switch Voltage ----- -0.3V to (V<sub>DD</sub> + 0.8V)
- Other I/O Pin Voltages ----- -0.3V to (V<sub>DD</sub> + 0.3V)
- LX Pin Switch Current ----- 2.5A
- EXT Pin Driver Current ----- 200mA
- Power Dissipation, P<sub>D</sub> @ T<sub>A</sub> = 25°C  
   SOT-23-6 ----- 0.25W
- Package Thermal Resistance  
   SOT-23-6, θ<sub>JA</sub> ----- 250°C/W
- Operating Junction Temperature ----- 125°C
- Storage Temperature Range ----- -65°C to +150°C

## Electrical Characteristics

(V<sub>IN</sub> = 3.3V, V<sub>DD</sub> set to 5V, Load Current = 0, T<sub>A</sub> = 25°C, unless otherwise specified)

Parameter	Symbol	Test Conditions	Min	Typ	Max	Unit
Start-UP Voltage	V <sub>ST</sub>	I <sub>L</sub> = 1mA	--	0.98	1.05	V
Operating V <sub>DD</sub> Range	V <sub>DD</sub>	V <sub>DD</sub> pin voltage	2	--	6.5	V
No Load Current I (V <sub>IN</sub> )	I <sub>NO LOAD</sub>	V <sub>IN</sub> = 3.3V, V <sub>OUT</sub> = 5V	--	30	--	μA
Switch-off Current I (V <sub>DD</sub> )	I <sub>SWITCH</sub>	V <sub>IN</sub> = 6V	--	17	--	μA
Shutdown Current I (V <sub>IN</sub> )	I <sub>OFF</sub>	EN Pin = 0V, V <sub>IN</sub> = 6V	--	0.1	1	μA
Feedback Reference Voltage	V <sub>REF</sub>	Close Loop, V <sub>DD</sub> = 5V		0.25		V
Switching Rate	F <sub>S</sub>	V <sub>DD</sub> = 5V	--	500	--	kHz
Maximum Duty	D <sub>MAX</sub>	V <sub>DD</sub> = 5V	--	75	--	%
LX ON Resistance		V <sub>DD</sub> = 5V	--	0.4	--	Ω
Current Limit Setting	I <sub>LIMIT</sub>	V <sub>DD</sub> = 5V	--	500	--	mA
EXT ON Resistance to V <sub>DD</sub>		V <sub>DD</sub> = 5V	--	5	--	Ω
EXT ON Resistance to GND		V <sub>DD</sub> = 5V	--	5	--	Ω
EN Pin Trip Level		V <sub>DD</sub> = 5V	0.4	0.8	1.2	V
Temperature Stability for V <sub>REF</sub>	T <sub>S</sub>		--	50	--	ppm/°C
Thermal Shutdown	T <sub>SD</sub>		--	165	--	°C
Thermal Shutdown Hysterises	ΔT <sub>SD</sub>		--	10	--	°C

**Typical Operating Characteristics**

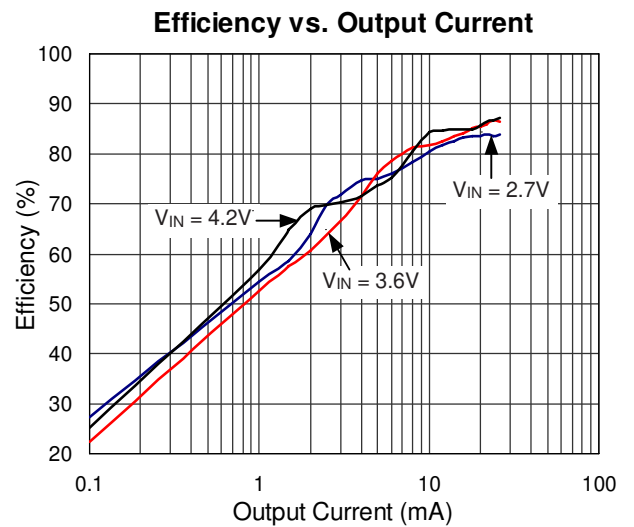
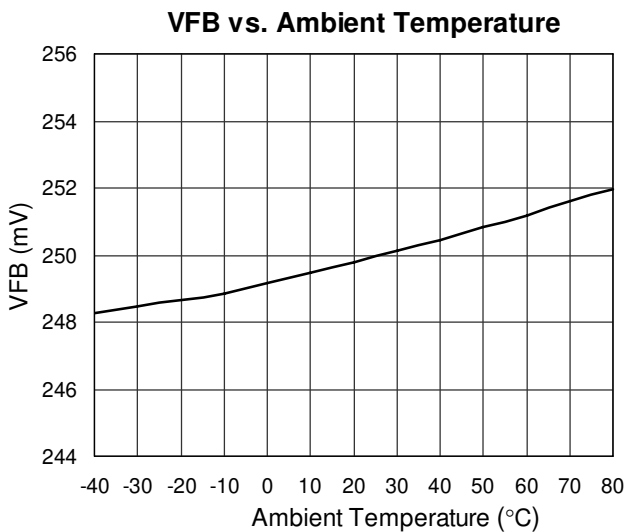
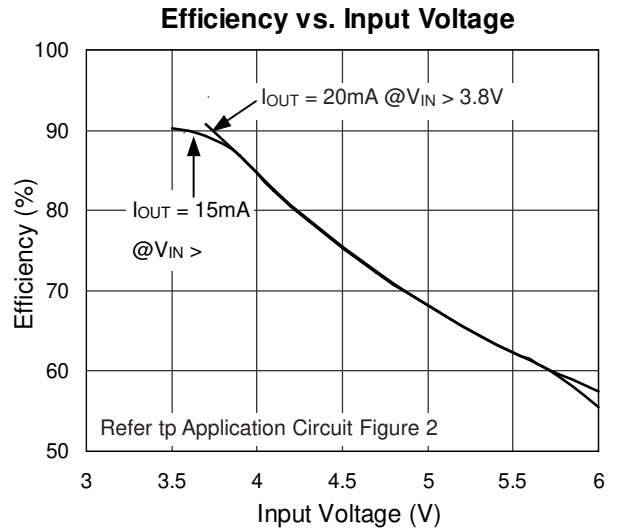
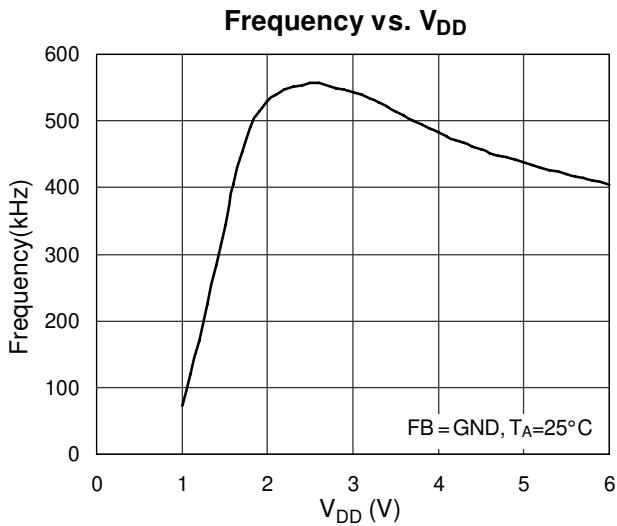
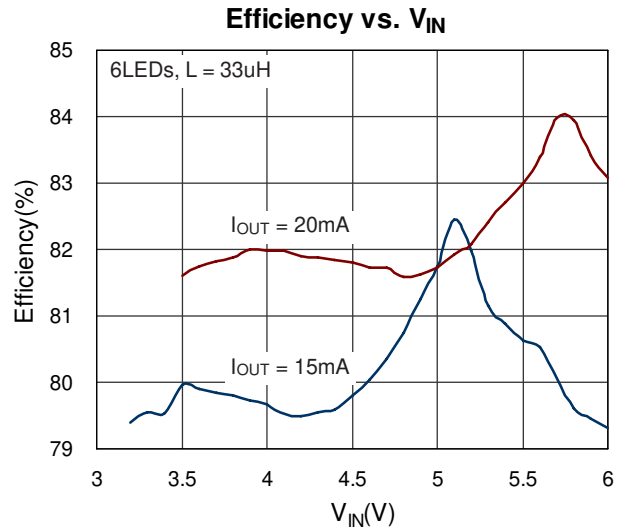
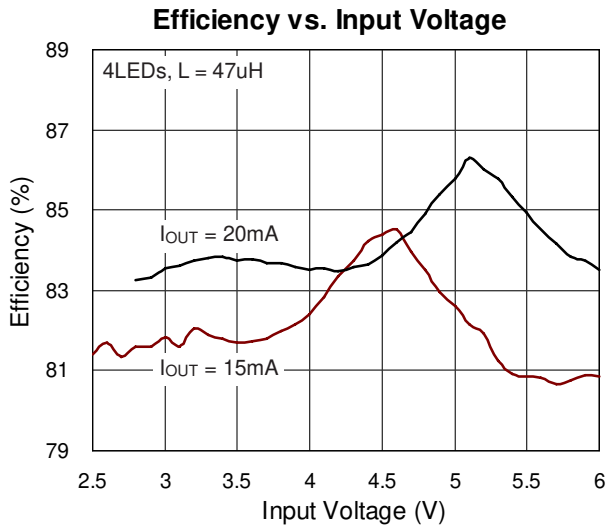

Power ON Waveform

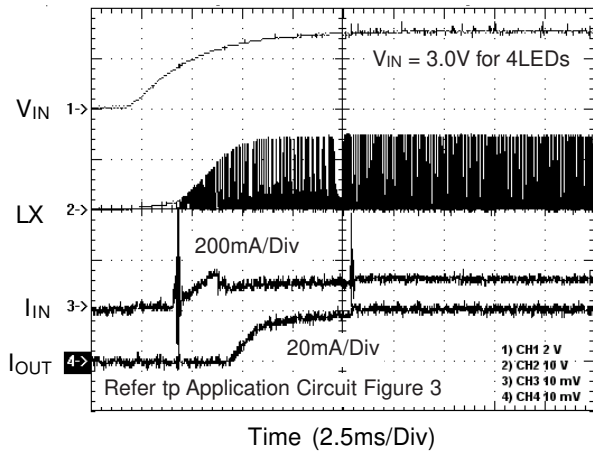

Power ON Waveform

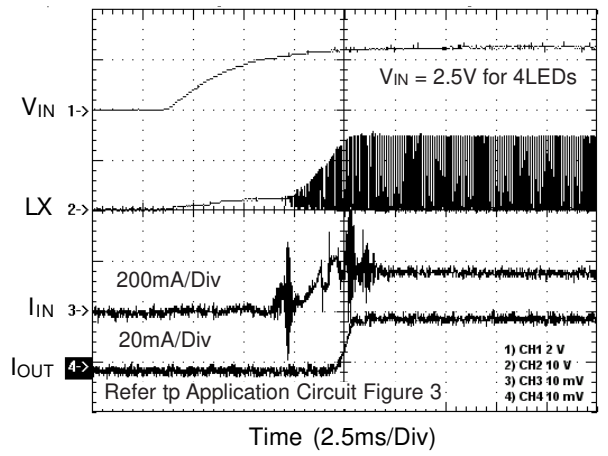

LX vs. Output Ripple

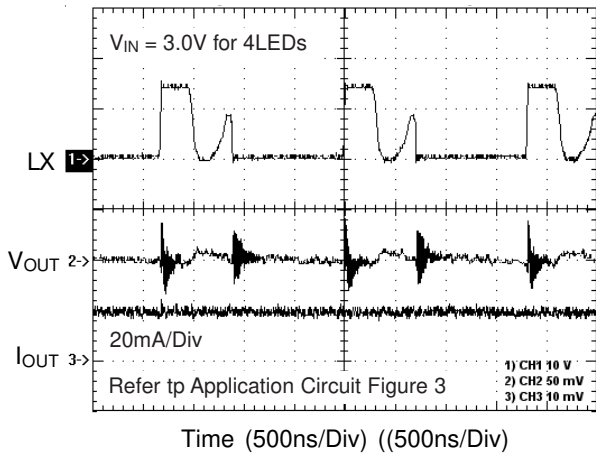

LX vs. Output Ripple

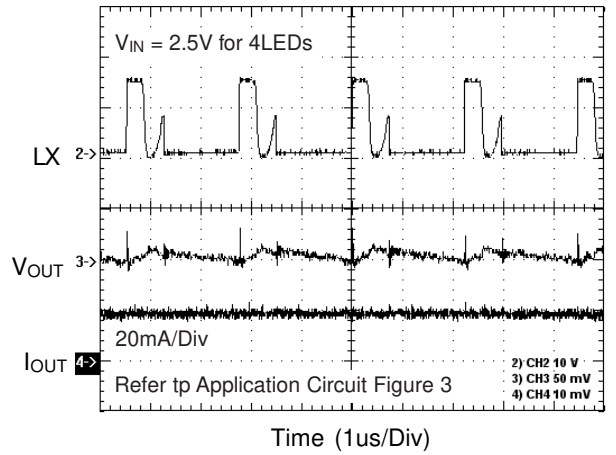

Power UP Waveform

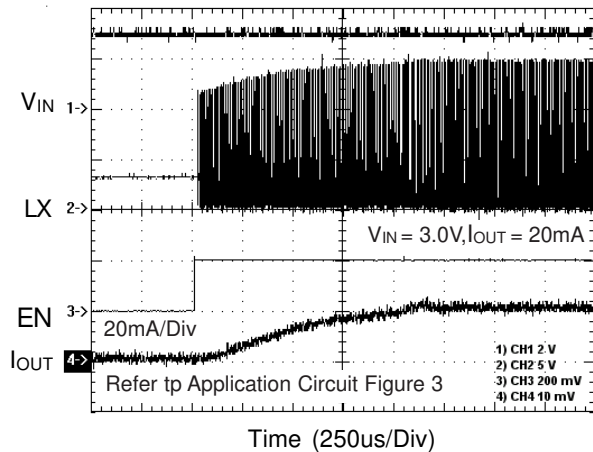

Power UP Waveform

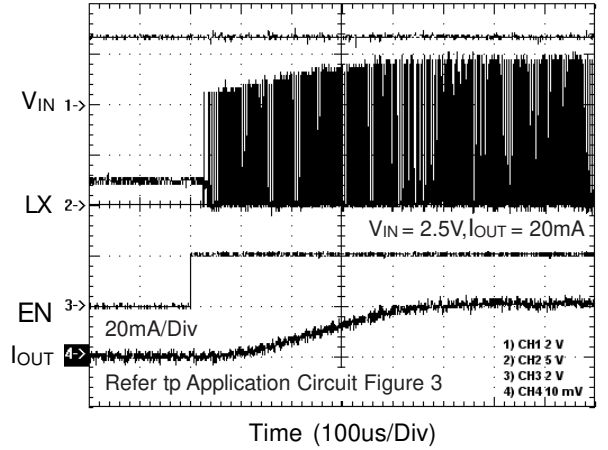

Power On Waveform

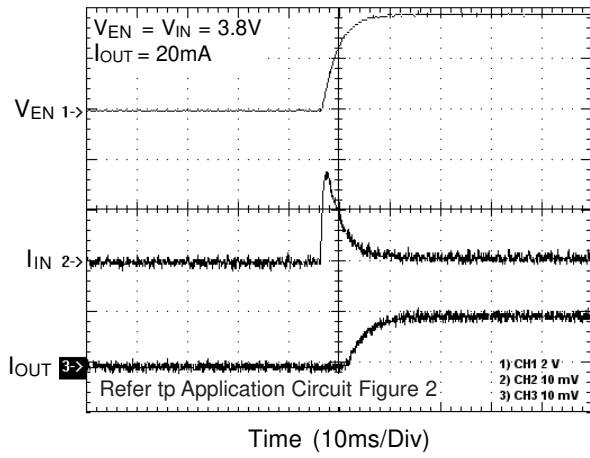

Power Up Waveform

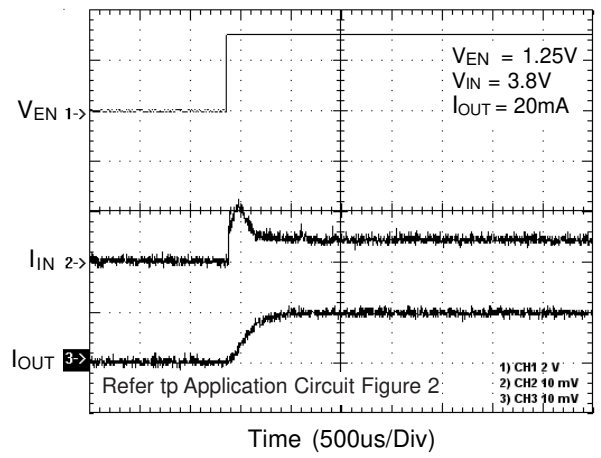

EN Pin Shutdown Response

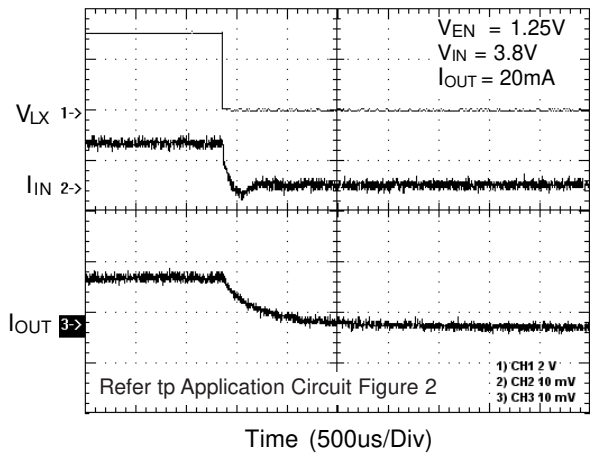

LX vs. Output Ripple

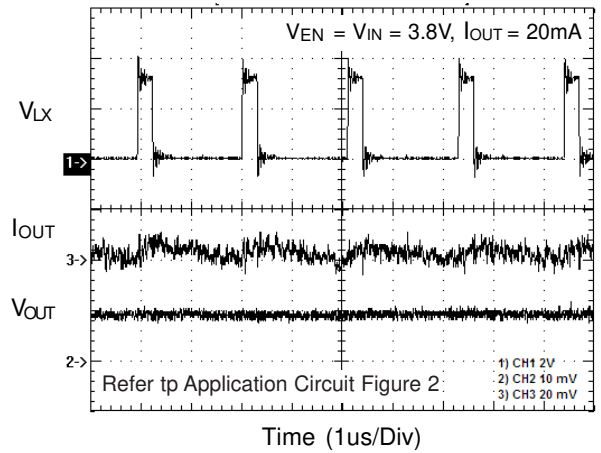

Power On Waveform

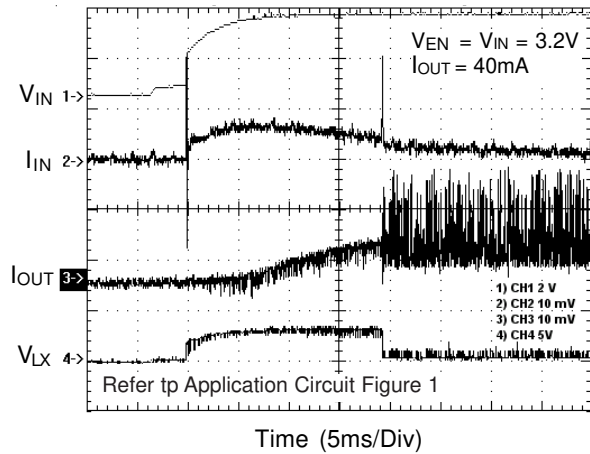

Power Up Waveform

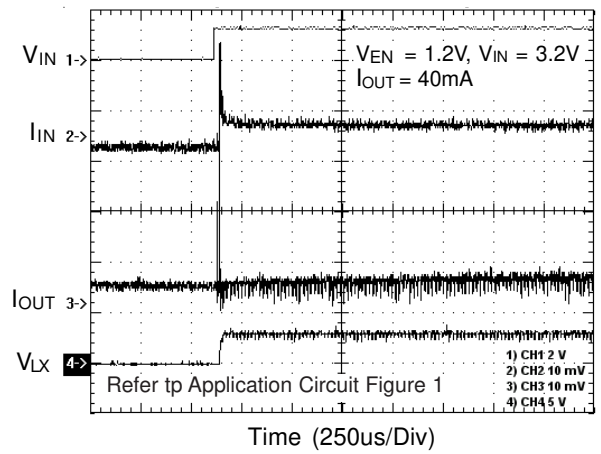



EN Pin Shutdown Response

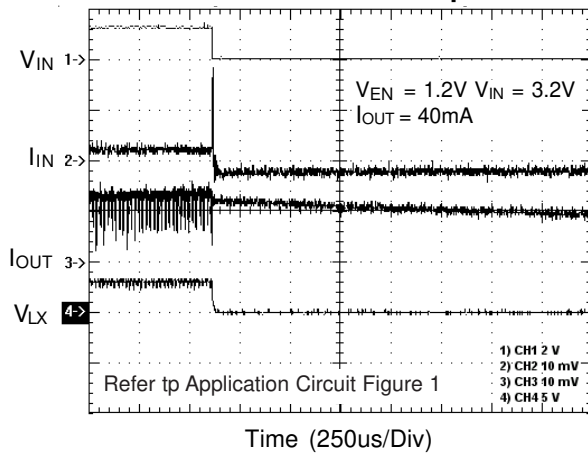

LX vs. Output Ripple

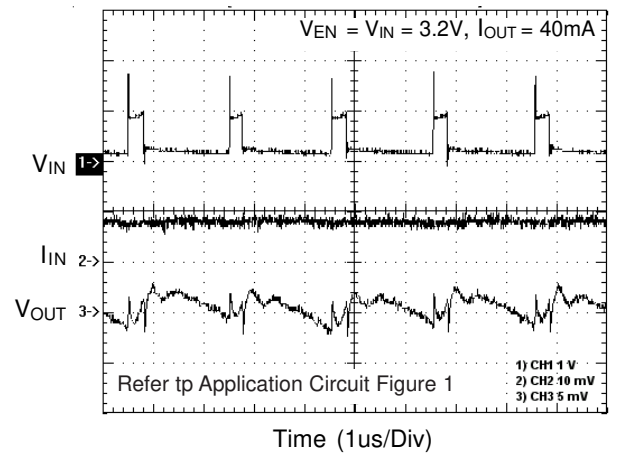

Brightness Control

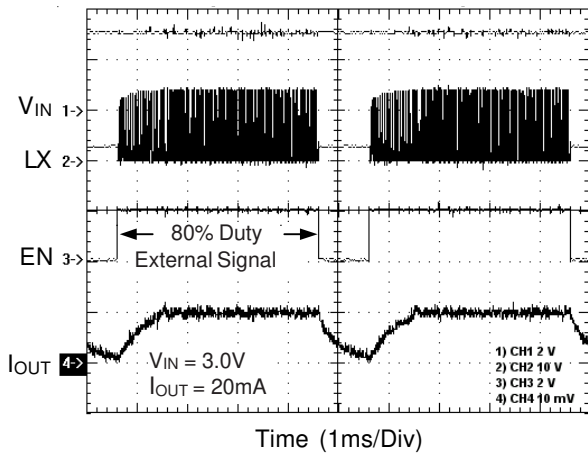

Brightness Control

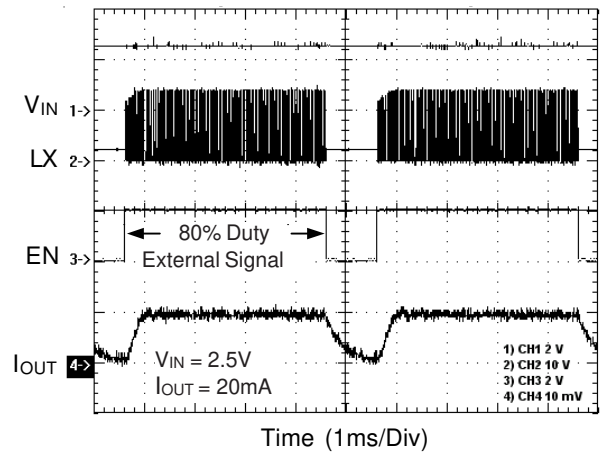

**Outline Dimension**

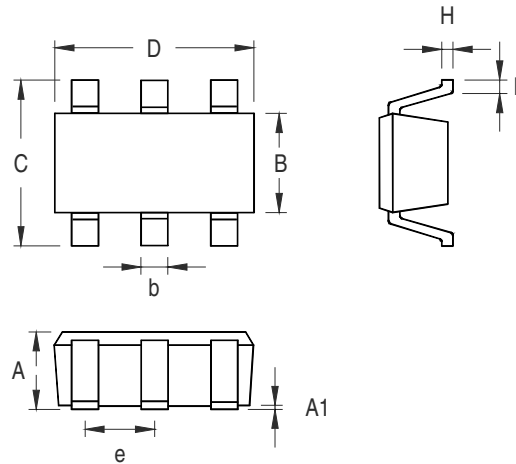

Symbol	Dimensions In Millimeters		Dimensions In Inches	
	Min	Max	Min	Max
A	0.889	1.295	0.031	0.051
A1	0.000	0.152	0.000	0.006
B	1.397	1.803	0.055	0.071
b	0.250	0.560	0.010	0.022
C	2.591	2.997	0.102	0.118
D	2.692	3.099	0.106	0.122
e	0.838	1.041	0.033	0.041
H	0.080	0.254	0.003	0.010
L	0.300	0.610	0.012	0.024

**SOT-23-6 Surface Mount Package**

**Richtek Technology Corporation**

Headquarter  
 5F, No. 20, Taiyuen Street, Chupei City  
 Hsinchu, Taiwan, R.O.C.  
 Tel: (8863)5526789 Fax: (8863)5526611

**Richtek Technology Corporation**

Taipei Office (Marketing)  
 5F, No. 95, Minchiuan Road, Hsintien City  
 Taipei County, Taiwan, R.O.C.  
 Tel: (8862)86672399 Fax: (8862)86672377  
 Email: marketing@richtek.com

Information that is provided by Richtek Technology Corporation is believed to be accurate and reliable. Richtek reserves the right to make any change in circuit design, specification or other related things if necessary without notice at any time. No third party intellectual property infringement of the applications should be guaranteed by users when integrating Richtek products into any application. No legal responsibility for any said applications is assumed by Richtek.