



Chipsmall Limited consists of a professional team with an average of over 10 year of expertise in the distribution of electronic components. Based in Hongkong, we have already established firm and mutual-benefit business relationships with customers from,Europe,America and south Asia,supplying obsolete and hard-to-find components to meet their specific needs.

With the principle of “Quality Parts,Customers Priority,Honest Operation,and Considerate Service”,our business mainly focus on the distribution of electronic components. Line cards we deal with include Microchip,ALPS,ROHM,Xilinx,Pulse,ON,Everlight and Freescale. Main products comprise IC,Modules,Potentiometer,IC Socket,Relay,Connector.Our parts cover such applications as commercial,industrial, and automotives areas.

We are looking forward to setting up business relationship with you and hope to provide you with the best service and solution. Let us make a better world for our industry!



Contact us

Tel: +86-755-8981 8866 Fax: +86-755-8427 6832

Email & Skype: info@chipsmall.com Web: www.chipsmall.com

Address: A1208, Overseas Decoration Building, #122 Zhenhua RD., Futian, Shenzhen, China



High Efficiency Boost LDO Converter & High Power White LED Driver

General Description

The RT9278 is a compact, high efficiency, synchronous step-up converter, it provides a power supply solution for products powered by either two-cell, three-cell Alkaline/ NiMH or one-cell Li-Ion/Li-polymer battery.

The RT9278 is boost converter with PWM control loop, provide up to 95% efficiency by using a synchronous rectifier. The maximum peak current in the internal switch is limited to up to 2A.

It keeps the output voltage regulated when the input voltage exceeds the setting output voltage. The output voltage can be set by an external resistor divider, or be fixed to reduce external components. It integrates a linear controller for linear regulator.

RT9278 is available in VDFN-10L 3x3 package.

Ordering Information

RT9278 □□

- Package Type
QV : VDFN-10L 3x3 (V-Type)
- Lead Plating System
P : Pb Free
G : Green (Halogen Free and Pb Free)

Note :

Richtek products are :

- ▶ RoHS compliant and compatible with the current requirements of IPC/JEDEC J-STD-020.
- ▶ Suitable for use in SnPb or Pb-free soldering processes.

Pin Configurations

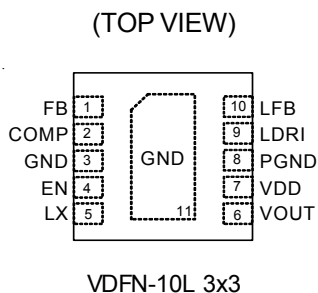

Features

- 95% Efficiency Synchronous Boost Converter
- High Supply Capability
- 2A Current Limit
- Input Voltage Range : 1.5V to 5.5V
- 600kHz Fixed Switching Rate
- Adjustable Output Voltage Options Up to 5.5V
- Output Voltage Keep Regulated when Input Voltage Exceed Setting Output Voltage
- 1uA Supply Current in Shutdown Mode
- External Compensation Network
- Build in Linear Controller for Linear Regulator
- Over Temperature Protection
- Small 10-Lead VDFN Package
- RoHS Compliant and 100% Lead (Pb)-Free

Applications

- Digital Still Camera
- Camera White LED Flash Light
- PDAs
- Portable Device

Marking Information

RT9278PQV

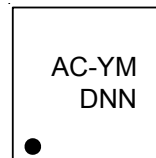

AC- : Product Code
YMDNN : Date Code

RT9278QQV

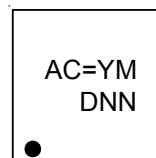

AC= : Product Code
YMDNN : Date Code

Typical Application Circuit

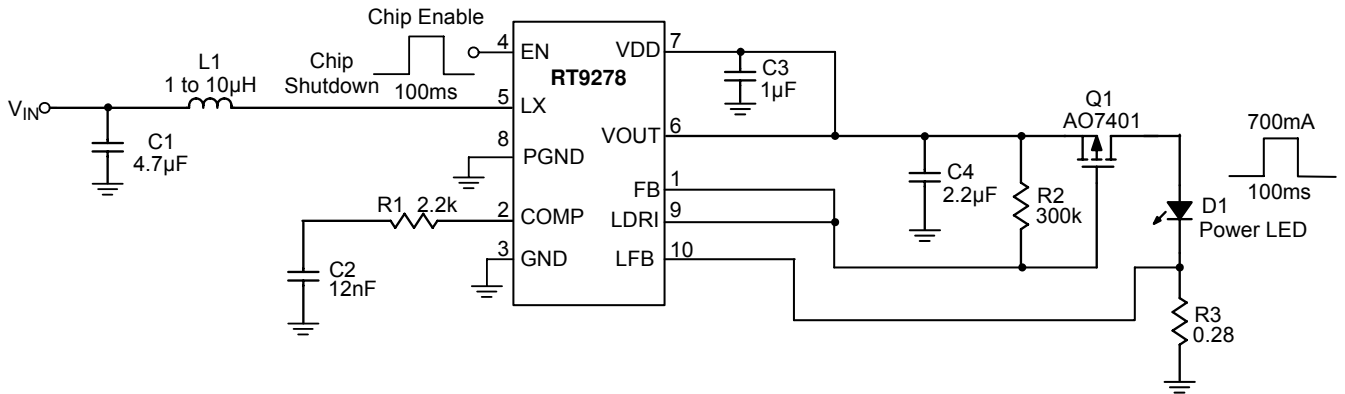

Figure 1. Novel Up-Down Driver for Power LED with Strobe Mode

Note : Patent Pending.

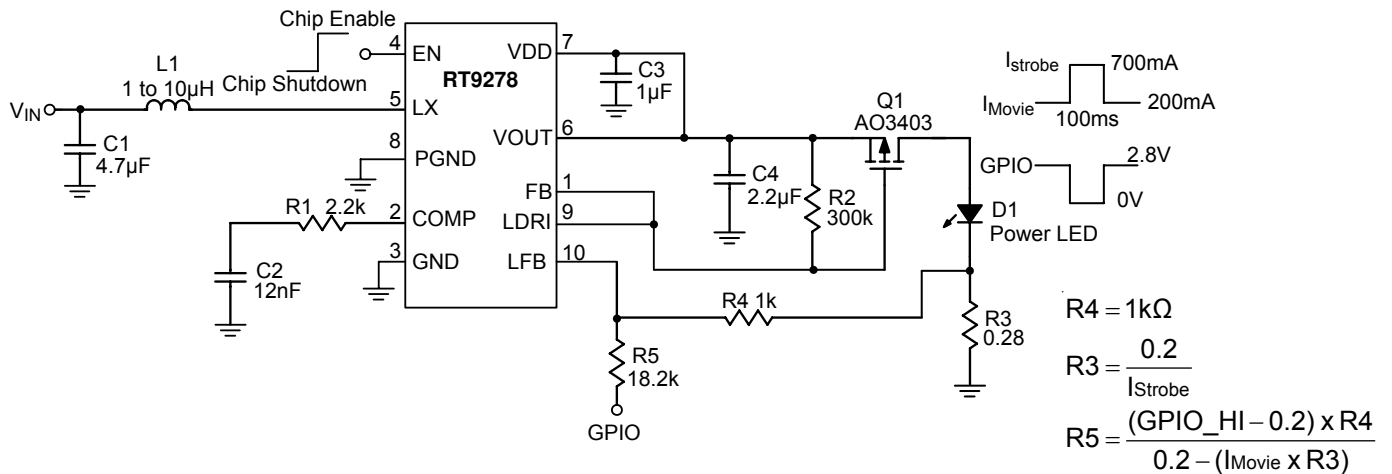

Figure 2. Novel Up-Down Driver for Power LED with Strobe Mode and Movie Mode

Note :

- Patent Pending.
- The GPIO Signal has to pull high before enable IC.

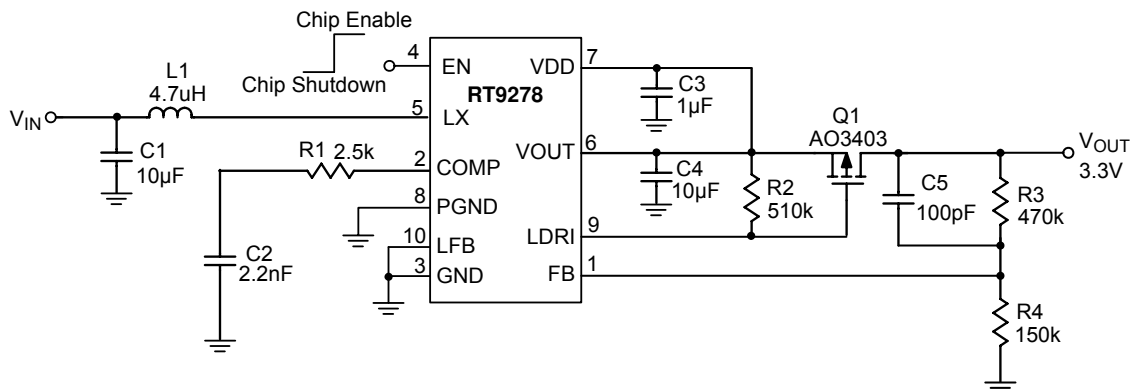

Figure 3. Synchronous Boost Converter with Load Disconnect in Shutdown

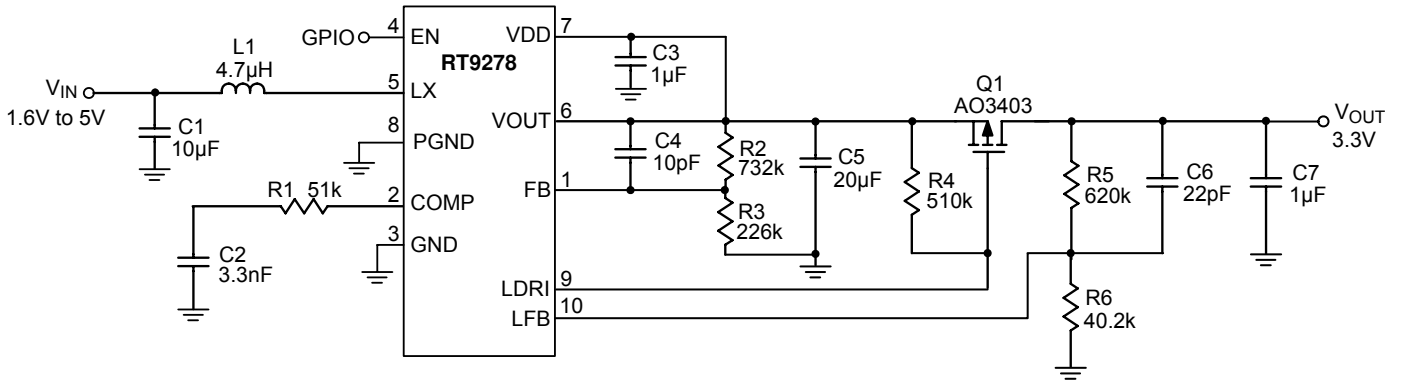

Figure 4. Boost-LDO Application for Constant Output Voltage

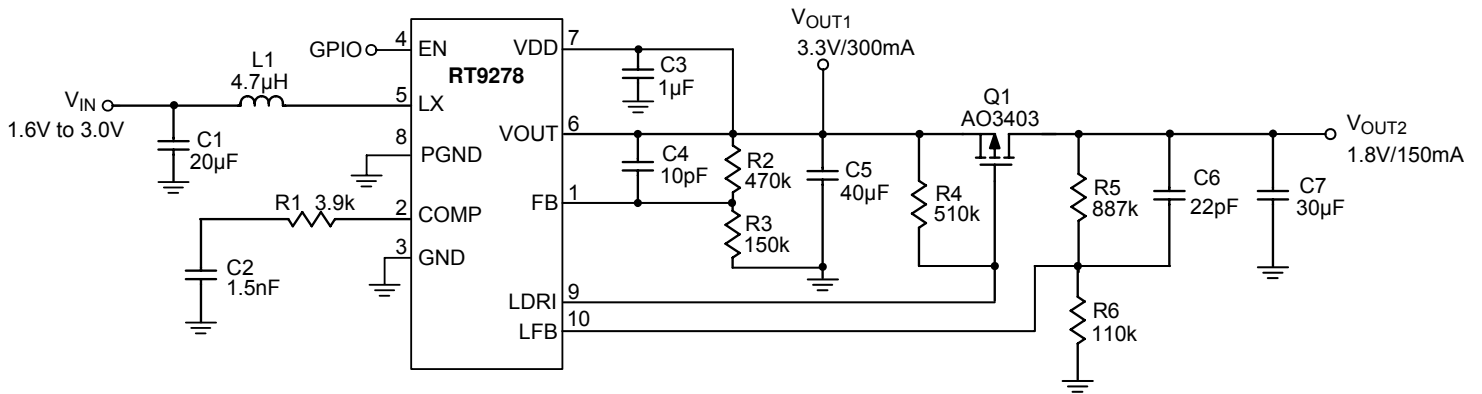

Figure 5. Synchronous Boost Converter Driver for Dual Output Voltage

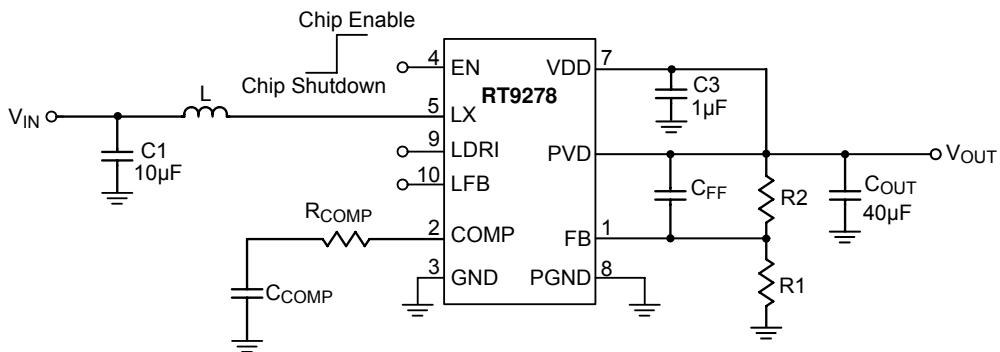

Figure 6. Synchronous Boost Converter

Table 1. Component Selection for Figure 6 (L=2.2μH)

Input Voltage (V)	Output Voltage (V)	L (μH)	C _{OUT} (μF)	R1 (kΩ)	R2 (kΩ)	R _{COMP} (kΩ)	C _{COMP} (nF)	C _{FF} (pF)
1.5~3.0	3.3	2.2	40	150	470	43	5.6	18
1.5~3.3	5.0	2.2	40	130	680	24	8.2	12
3.0~4.5	5.0	2.2	40	130	680	24	3.9	12

Table 2. Component Selection for Figure 6 (L=4.7μH)

Input Voltage (V)	Output Voltage (V)	L (μH)	C _{OUT} (μF)	R1 (kΩ)	R2 (kΩ)	R _{COMP} (kΩ)	C _{COMP} (nF)	C _{FF} (pF)
1.5~3.0	3.3	4.7	40	150	470	24	10	18
1.5~3.3	5.0	4.7	40	130	680	24	15	12
3.0~4.5	5.0	4.7	40	130	680	24	8.2	12

Table 3. Component Selection for Figure 6 (L=6.8μH)

Input Voltage (V)	Output Voltage (V)	L (μH)	C _{OUT} (μF)	R1 (kΩ)	R2 (kΩ)	R _{COMP} (kΩ)	C _{COMP} (nF)	C _{FF} (pF)
1.5~3.0	3.3	6.8	40	150	470	24	15	18
1.5~3.3	5.0	6.8	40	130	680	24	22	12
3.0~4.5	5.0	6.8	40	130	680	24	12	12

Table 4. Component Selection for Figure 6 (L=10μH)

Input Voltage (V)	Output Voltage (V)	L (μH)	C _{OUT} (μF)	R1 (kΩ)	R2 (kΩ)	R _{COMP} (kΩ)	C _{COMP} (nF)	C _{FF} (pF)
1.5~3.0	3.3	10	40	150	470	24	22	18
1.5~3.3	5.0	10	40	130	680	24	33	12
3.0~4.5	5.0	10	40	130	680	24	18	12

Functional Pin Description

Pin No.	Pin Name	Pin Function
1	FB	Feedback Input Pin.
2	COMP	Feedback Compensation Pin.
3	GND	Ground.
4	EN	Enable Input Pin
5	LX	Switch Node.
6	VOUT	Output Pin
7	VDD	Device Input Power Pin.
8	PGND	Power Ground.
9	LDRI	Linear Controller Driver Output.
10	LFB	Linear Controller Feedback Input.
11 (Exposed Pad)	GND	The exposed pad must be soldered to a large PCB and connected to GND for maximum power dissipation.

Function Block Diagram

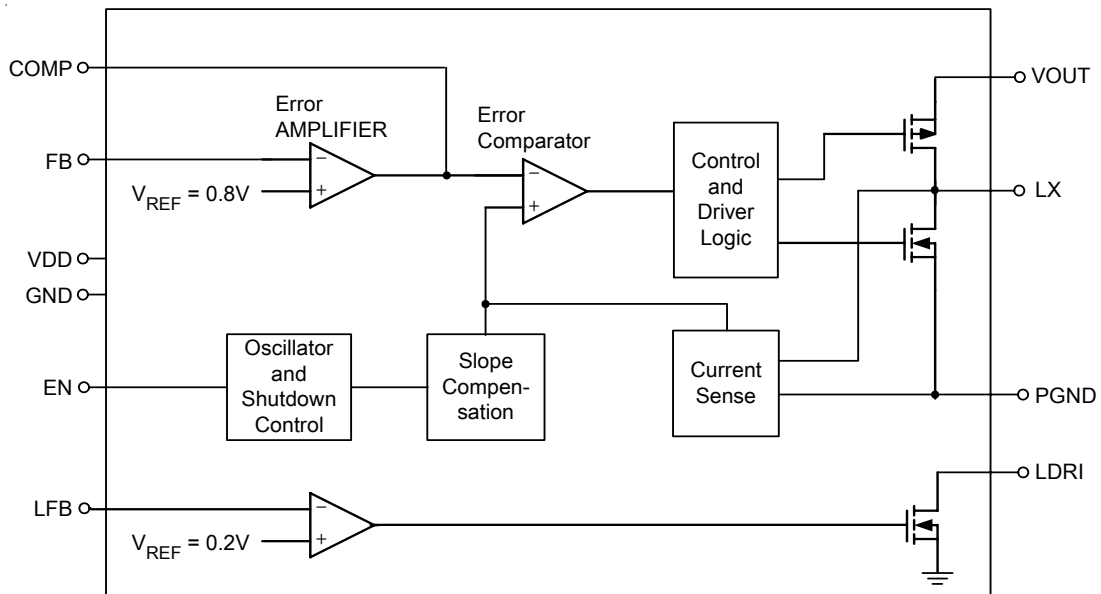

Operation

RT9278 integrates a high-efficiency step-up DC-DC converter and a linear regulator controller. The boost converter is based on a fixed frequency, pulse-width-modulation (PWM) controller using a synchronous rectifier to obtain maximum efficiency. Current mode control with external compensation network makes it easy to stabilize the system and keep maximum flexibility. The linear regulator controller can use to drive the external P-Channel MOSFET switch for load disconnection. It keeps the output voltage regulated even when the input voltage exceeds the nominal output voltage, and keeps the output voltage completely disconnected from input voltage (battery) when the chip is in shutdown mode

Soft-start

When the chip is enabled. Soft-start is achieved by ramping up the PWM duty from very small to normal operation. The ramping up PWM duty is achieved by sourcing 1uA from error amplifier to the compensation capacitor. When the output voltage is regulated, the PWM duty enters the normal operation, and the error amplifier can sink and source up to 22uA. The soft-start time is set by the following formula :

$$T_{SS} = \frac{(1V - 1\mu A \times R_{COMP}) \times C_{COMP}}{1\mu A}$$

R_{COMP} and C_{COMP} are compensation components.

Current limit

The current of NMOS is sensed cycle by cycle to prevent over current. When over current limit, then the NMOS is off. This state is latched and then reset automatically at next clock cycle.

Over voltage

When the chip voltage is higher than 6.5V, Switch is off. When the Over Voltage Protection is relieved, the chip operates well again.

Thermal protection

Thermal protection function is integrated in the chip. When the chip temperature is higher than 180°C, the controllers are shutdown. 20°C is the hysteresis range of temperature to prevent unstable operation when the thermal protection happens. When the thermal protection is relieved, the chip operates well again.

Absolute Maximum Ratings (Note 1)

- Supply Voltage, V_{DD} ----- 7V
- LX Pin Voltage ----- -0.3V to 7V
- The Other pins ----- -0.3V to 7V
- Power Dissipation, $P_D @ T_A = 25^\circ\text{C}$
 - VDFN-10L 3x3 ----- 1.43W
- Package Thermal Resistance (Note 2)
 - VDFN-10L 3x3, θ_{JA} ----- 70°C/W
- Lead Temperature (Soldering, 10 sec.) ----- 260°C
- Junction Temperature ----- 150°C
- Storage Temperature Range ----- -65°C to 150°C
- ESD Susceptibility (Note 3)
 - HBM (Human Body Mode) ----- 2kV

Recommended Operating Conditions (Note 4)

- Ambient Temperature Range ----- -40°C to 85°C
- Junction Temperature Range ----- -40°C to 125°C

Electrical Characteristics

($V_{BAT} = 1.8\text{V}$, $V_{OUT} = 3.3\text{V}$, $T_A = 25^\circ\text{C}$, unless otherwise specified)

Parameter	Symbol	Test Conditions	Min	Typ	Max	Unit
Start-Up Voltage	V_{ST}	$I_L = 1\text{mA}$	--	1.5	--	V
Operating Voltage Range, After start-up	V_{BAT}		1.1	--	5.5	V
VO _{UT} Output Voltage Range	V_{OUT_ADJ}		2.4	--	5.5	V
VO _{UT} Over Voltage Protection			--	6.5	--	V
Switch-off Current I (V_{BAT})	$I_{SW\ OFF}$	$V_{OUT} = 3.3\text{V}$, $V_{FB} = 0.9\text{V}$	--	200	350	μA
Shutdown Current	I_{OFF}	EN Pin = 0V, Open Loop	--	0.01	1	μA
Feedback Reference Voltage	V_{FB}	Close Loop, $V_{OUT} = 3.3\text{V}$	0.784	0.8	0.816	V
Switching Frequency	f_S		--	650	--	kHz
Maximum Duty	$D_{(MAX)}$		--	85	--	%
SW _N Switch ON Resistance		$V_{OUT} = 3.3\text{V}$	--	210	--	$\text{m}\Omega$
SW _P Switch ON Resistance		$V_{OUT} = 3.3\text{V}$	--	240	--	$\text{m}\Omega$
Current Limit Setting	I_{SW}	$V_{OUT} = 3.3\text{V}$	--	2	--	A
Error Amplifier						
GM			--	0.2	--	ms
Compensation Source Current			--	22	--	μA
Compensation Sink Current			--	22	--	μA

Parameter	Symbol	Test Conditions	Min	Typ	Max	Unit
Linear Controller						
Feedback Voltage for Linear Controller		V_{LFB}	--	0.2	--	V
EN Input High Level Threshold			--	--	1.3	V
EN Input Low Level Threshold			0.4	--	--	V
Thermal Shutdown	T_{SD}		--	180	--	°C
Thermal Shutdown Hysteresis	ΔT_{SD}		--	20	--	°C

Note 1. Stresses beyond those listed “Absolute Maximum Ratings” may cause permanent damage to the device. These are stress ratings only, and functional operation of the device at these or any other conditions beyond those indicated in the operational sections of the specifications is not implied. Exposure to absolute maximum rating conditions may affect device reliability.

Note 2. θ_{JA} is measured at $T_A = 25^\circ\text{C}$ on a high effective thermal conductivity four-layer test board per JEDEC 51-7.

Note 3. Devices are ESD sensitive. Handling precaution is recommended.

Note 4. The device is not guaranteed to function outside its operating conditions.

Typical Operating Characteristics

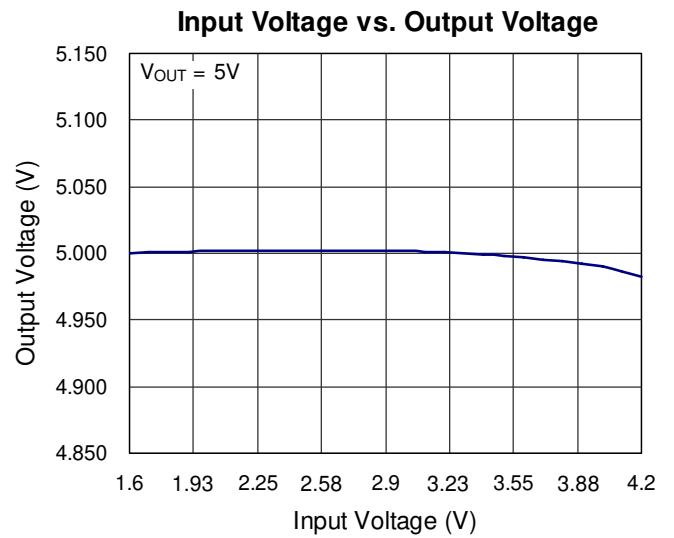
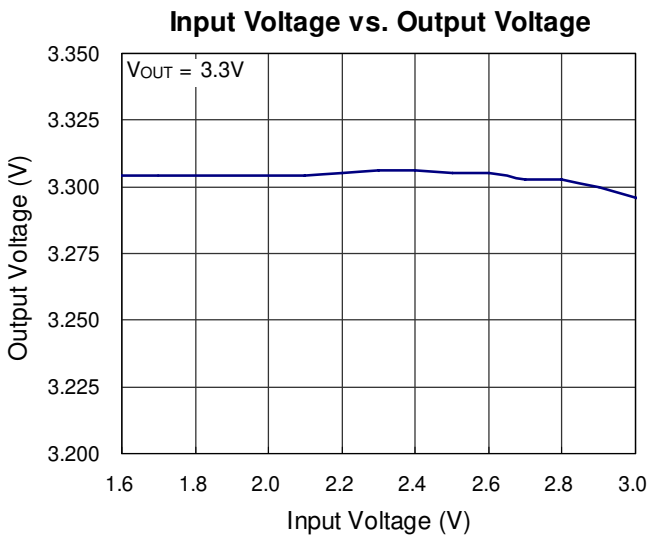
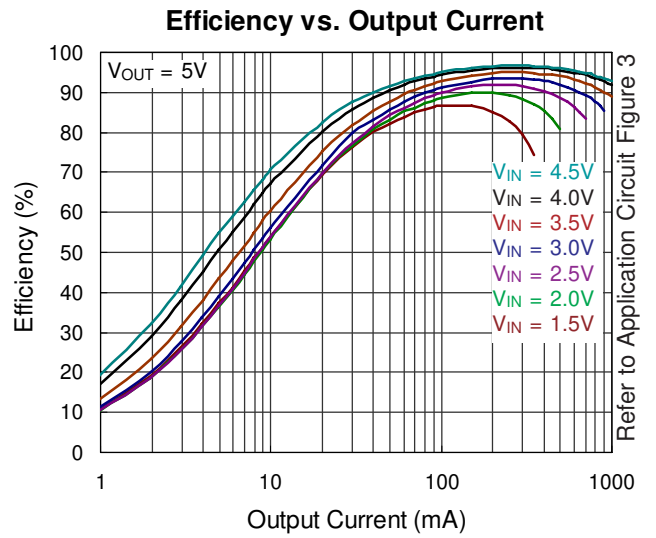
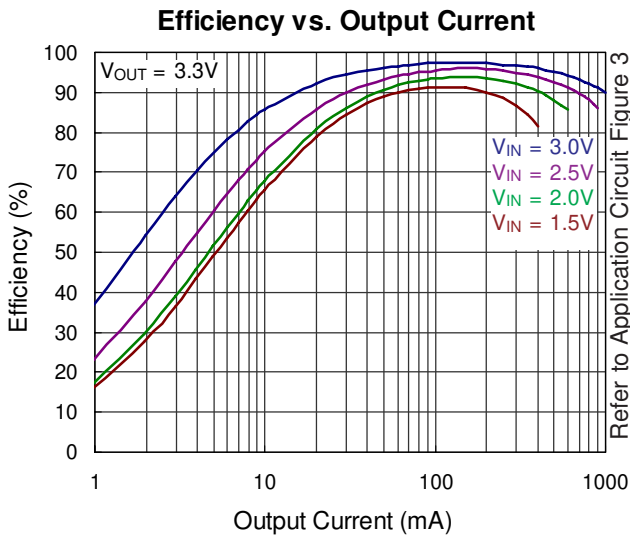
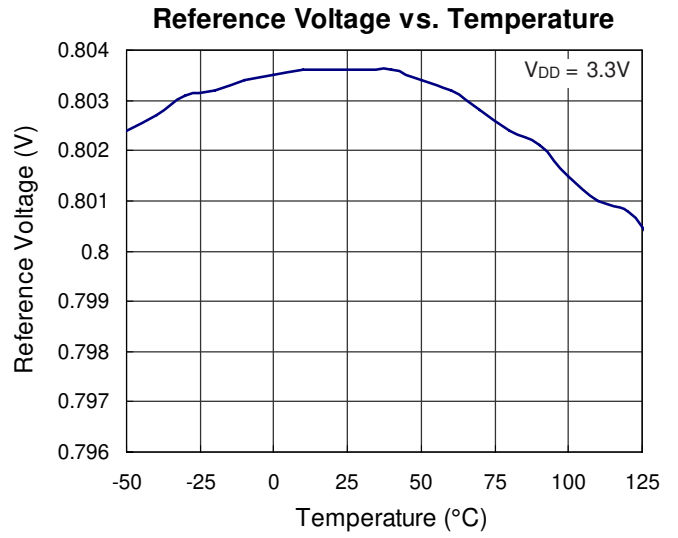
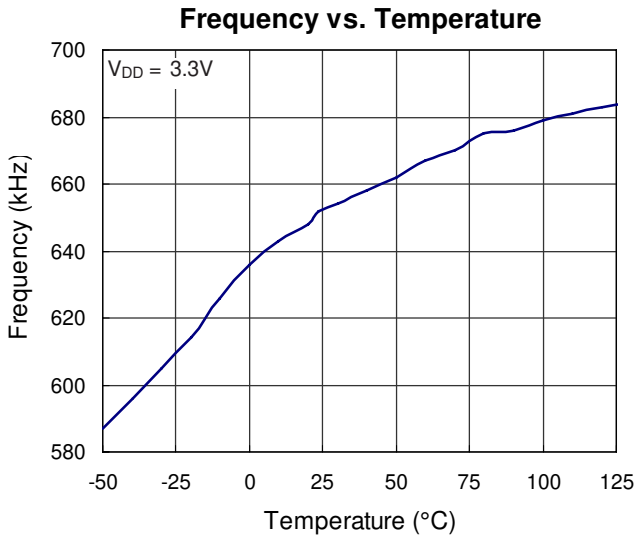

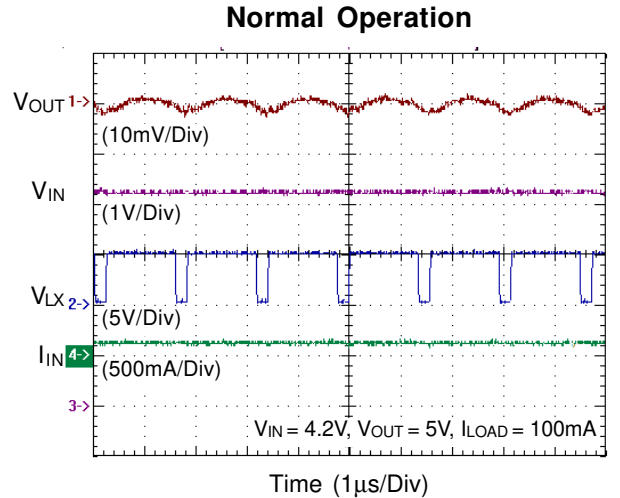
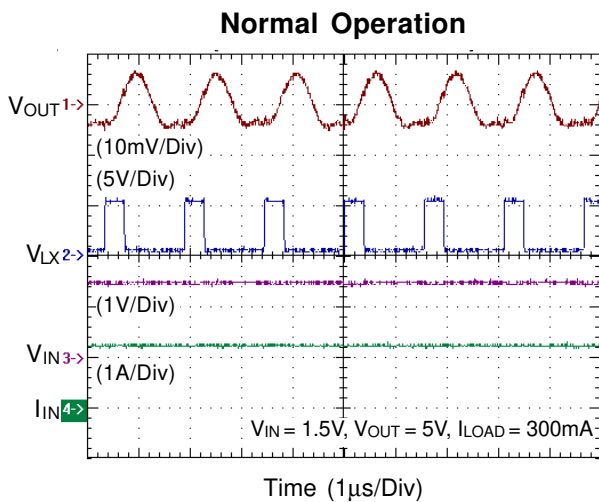
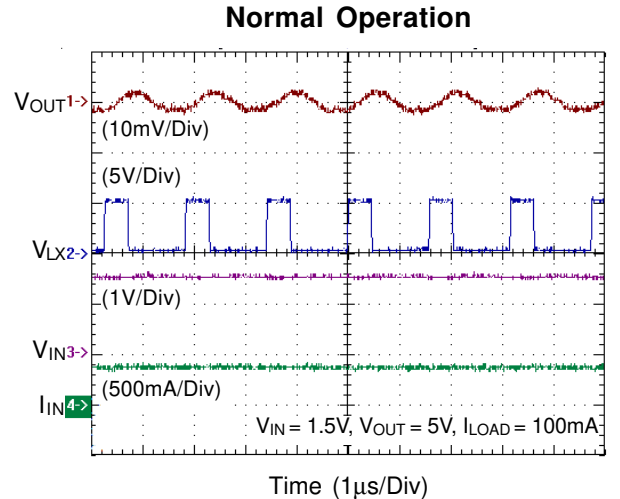
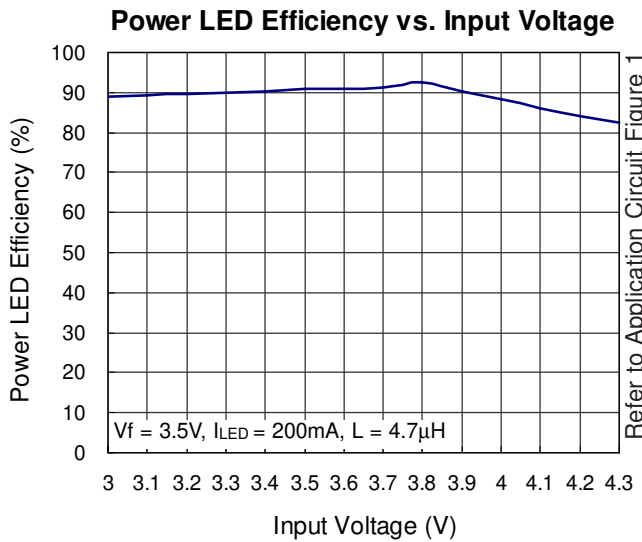
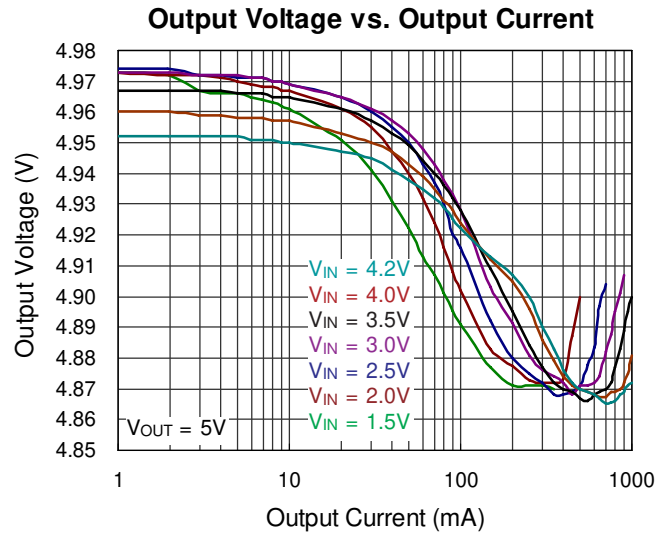
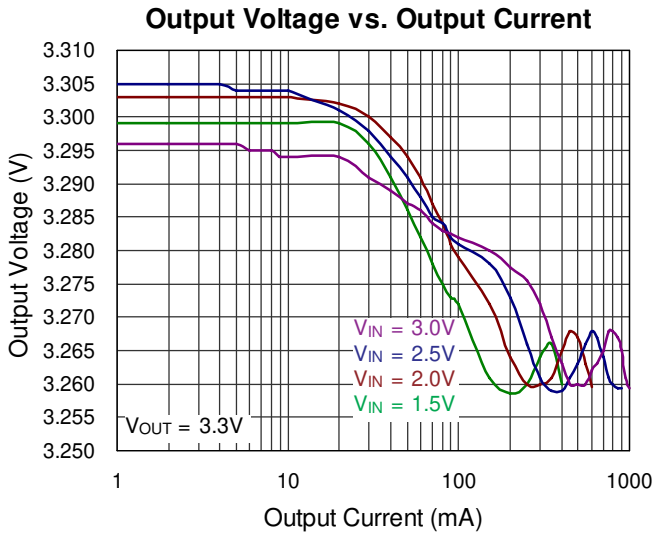

Normal Operation

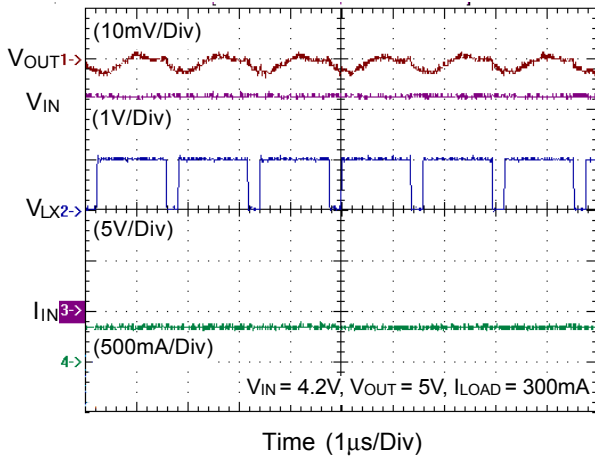

Load Transient Regulation

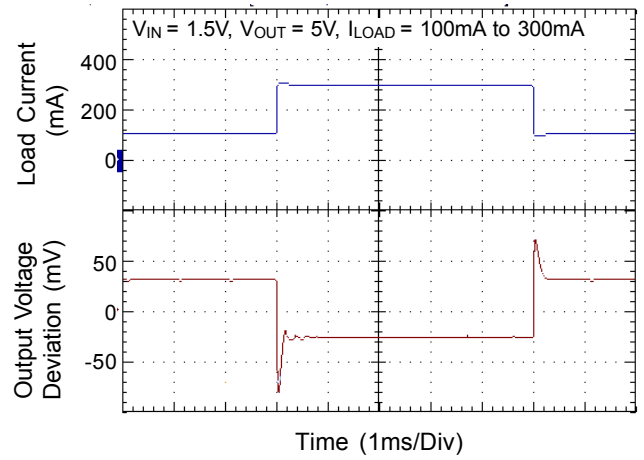

Load Transient Regulation

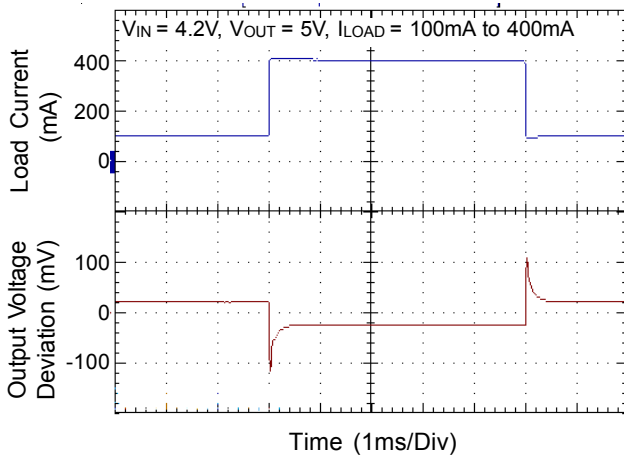

Flash LED

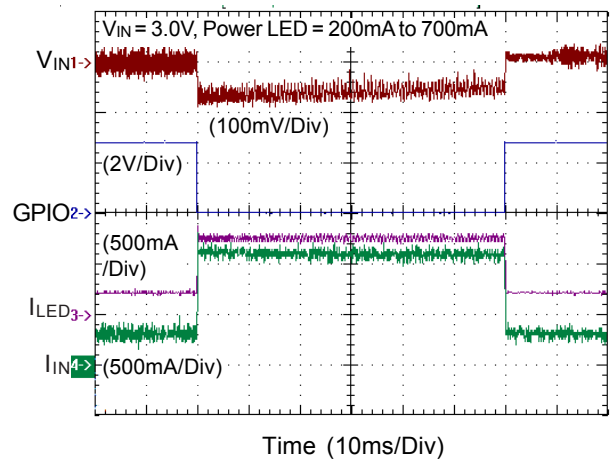

Flash LED

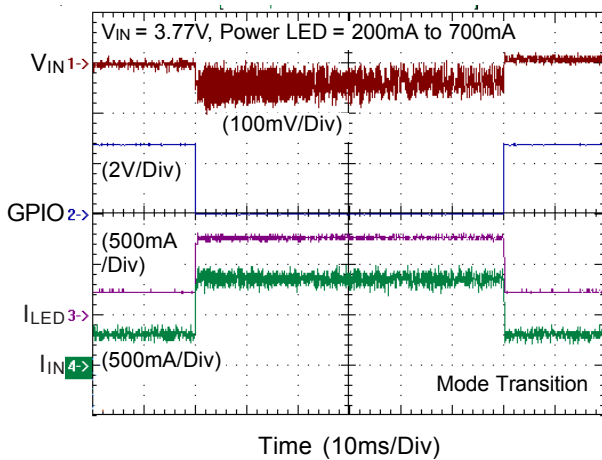

Flash LED

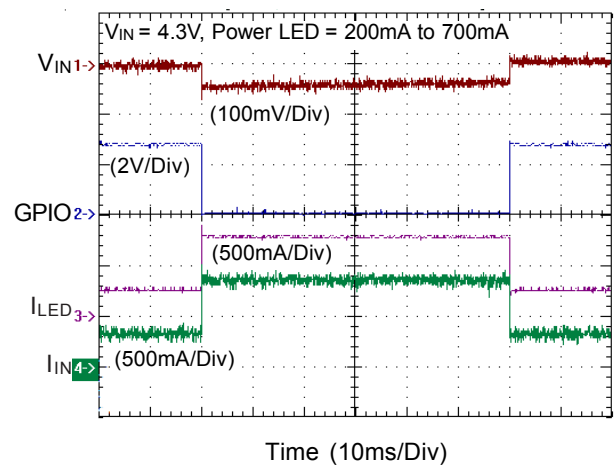

Application Information

RT9278 integrates a high-efficiency synchronous rectifier step-up DC-DC converter and a linear regulator controller. To fully utilize its advantages, peripheral components should be appropriately selected. The following information provides basic considerations for component selection.

Inductor Selection

For a better efficiency in high switching frequency converter, the inductor selection has to use a proper core material such as ferrite core to reduce the core loss and choose low ESR wire to reduce copper loss. The most important point is to prevent the core saturated when handling the maximum peak current. Using a shielded inductor can minimize radiated noise in sensitive applications. The maximum peak inductor current is the maximum input current plus the half of inductor ripple current. The calculated peak current has to be smaller than the current limitation in the electrical characteristics. A typical setting of the inductor ripple current is 20% to 40% of the maximum input current. If the selection is 40%

$$I_{PK} = I_{IN(MAX)} + \frac{1}{2} I_{RIPPLE} = 1.2 \times I_{IN(MAX)}$$

$$= 1.2 \times \left[\frac{(I_{OUT(MAX)} \times V_{OUT})}{\eta \times V_{IN(MIN)}} \right]$$

The minimum inductance value is derived from the following equation :

$$L = \frac{\eta \times I_{IN(MIN)}^2 \times [V_{OUT} - V_{IN(MIN)}]}{0.4 \times I_{OUT(MAX)} \times V_{OUT}^2 \times f_{OSC}}$$

Depending on the application, the recommended inductor value is between 2.2μH and 10μH.

Input Capacitor Selection

For better input bypassing, low-ESR ceramic capacitors are recommended for performance. A 10μF input capacitor is sufficient for most applications. For a lower output power requirement application, this value can be decreased.

Output Capacitor Selection

For lower output voltage ripple, low-ESR ceramic capacitors are recommended. The tantalum capacitors can be used

as well, but the ESR is bigger than ceramic capacitor. The output voltage ripple consists of two components: one is the pulsating output ripple current flows through the ESR, and the other is the capacitive ripple caused by charging and discharging.

$$V_{RIPPLE} = V_{RIPPLE(ESR)} + V_{RIPPLE(C)}$$

$$\cong I_{PEAK} \times ESRC_{OUT} + \frac{I_{PP}}{2 \times C \times f}$$

Output Voltage Setting

Referring to application circuits (Figure 6), the output voltage of the switching regulator (V_{OUT}) can be set with below equation :

$$V_{OUT} = \left(1 + \frac{R2}{R1}\right) \times V_{FB},$$

$$V_{FB} = 0.8V \text{ (typ.)}$$

Linear Regulator

Linear Regular MOSFETs Selection

The linear controller of RT9278 was designed to drive an external P-Channel MOSFET. The main consideration of pass MOSFETs of linear regulator is package selection for efficient removal of heat. The power dissipation of a linear regulator is

$$P_{linear} = (V_{IN} - V_{OUT}) \times I_{OUT} \quad (W)$$

The criterion for selection of package is the junction temperature below the maximum desired temperature with the maximum expected ambient temperature.

Layout Consideration

- ▶ A full GND plane without gap break.
- ▶ V_{DD} to GND noise bypass – Short and wide connection for the 1μF MLCC capacitor between Pin7 and Pin3.
- ▶ V_{IN} to GND noise bypass – Add a capacitor close to L1 inductor, when V_{IN} is not an ideal voltage source.
- ▶ Minimized FB node copper area and keep far away from noise sources.
- ▶ The MOSFETs of linear regulator should have wide pad to dissipate the heat.

Outline Dimension

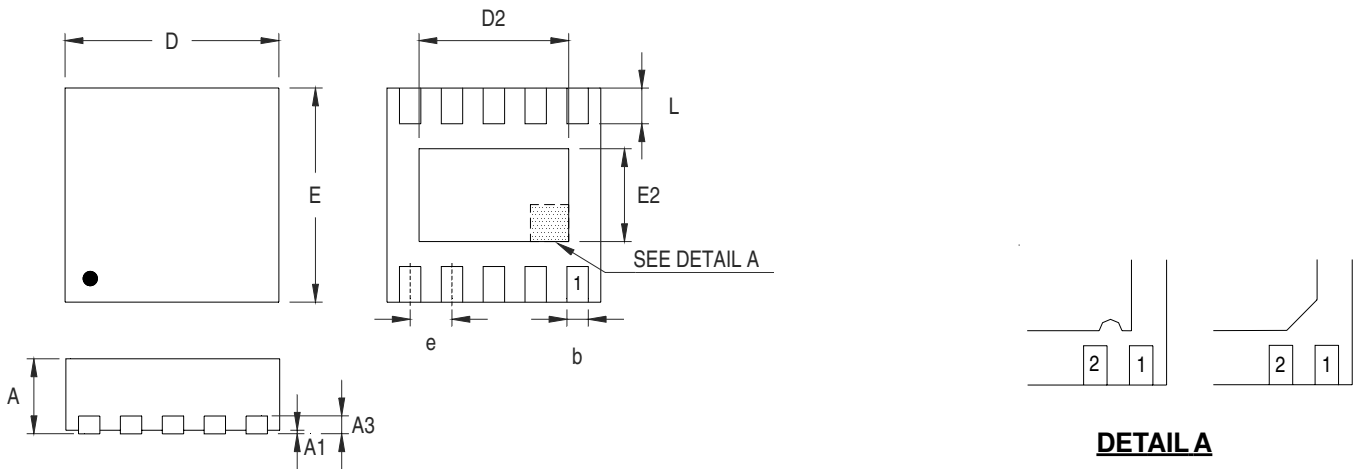

DETAIL A
Pin #1 ID and Tie Bar Mark Options

Note : The configuration of the Pin #1 identifier is optional, but must be located within the zone indicated.

Symbol	Dimensions In Millimeters		Dimensions In Inches	
	Min	Max	Min	Max
A	0.800	1.000	0.031	0.039
A1	0.000	0.050	0.000	0.002
A3	0.175	0.250	0.007	0.010
b	0.180	0.300	0.007	0.012
D	2.950	3.050	0.116	0.120
D2	2.300	2.650	0.091	0.104
E	2.950	3.050	0.116	0.120
E2	1.500	1.750	0.059	0.069
e	0.500		0.020	
L	0.350	0.450	0.014	0.018

V-Type 10L DFN 3x3 Package

Richtek Technology Corporation

5F, No. 20, Taiyuen Street, Chupei City
Hsinchu, Taiwan, R.O.C.
Tel: (8863)5526789

Richtek products are sold by description only. Richtek reserves the right to change the circuitry and/or specifications without notice at any time. Customers should obtain the latest relevant information and data sheets before placing orders and should verify that such information is current and complete. Richtek cannot assume responsibility for use of any circuitry other than circuitry entirely embodied in a Richtek product. Information furnished by Richtek is believed to be accurate and reliable. However, no responsibility is assumed by Richtek or its subsidiaries for its use; nor for any infringements of patents or other rights of third parties which may result from its use. No license is granted by implication or otherwise under any patent or patent rights of Richtek or its subsidiaries.