



Chipsmall Limited consists of a professional team with an average of over 10 year of expertise in the distribution of electronic components. Based in Hongkong, we have already established firm and mutual-benefit business relationships with customers from,Europe,America and south Asia,supplying obsolete and hard-to-find components to meet their specific needs.

With the principle of “Quality Parts,Customers Priority,Honest Operation,and Considerate Service”,our business mainly focus on the distribution of electronic components. Line cards we deal with include Microchip,ALPS,ROHM,Xilinx,Pulse,ON,Everlight and Freescale. Main products comprise IC,Modules,Potentiometer,IC Socket,Relay,Connector.Our parts cover such applications as commercial,industrial, and automotives areas.

We are looking forward to setting up business relationship with you and hope to provide you with the best service and solution. Let us make a better world for our industry!



Contact us

Tel: +86-755-8981 8866 Fax: +86-755-8427 6832

Email & Skype: info@chipsmall.com Web: www.chipsmall.com

Address: A1208, Overseas Decoration Building, #122 Zhenhua RD., Futian, Shenzhen, China



5A Single Cell Li-Ion Switching Battery Charger with Power Path Management and USB-OTG Boost Mode

General Description

The RT9467 is a switch-mode single cell Li-Ion/Li-Polymer battery charger for portable applications. It integrates a synchronous PWM controller, power MOSFETs, input current sensing and regulation, high-accuracy voltage regulation, and charge termination. The charge current is regulated through integrated sensing resistors. The RT9467 also features USB On-The-Go (OTG) support. RT9467 integrates D+/D- pin for USB host/charging port detection.

The RT9467 optimizes for charging task by using a control algorithm to vary the charge rate for different modes, including pre-charge mode, fast charge mode (constant voltage and constant current). The key charge parameters are programmable through an I²C interface. The RT9467 will resume the charge cycle whenever the battery voltage falls below an internal recharge threshold, and can automatically enter sleep mode if the input power supply is removed.

Other features include under-voltage protection, over voltage protection, thermal regulation and reverse leakage protection.

The RT9467 is available in a WQFN-24L 4x4 package.

Applications

- Cellular Telephones
- Personal Information Appliances
- Tablet PC, Power Bank
- Portable Instruments

Ordering Information

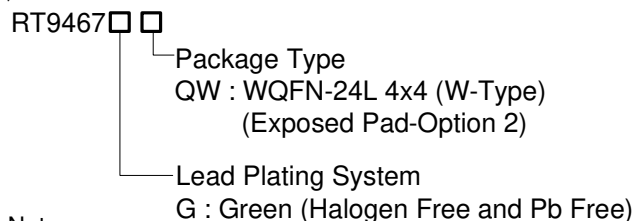

Note :

Richtek products are :

- ▶ RoHS compliant and compatible with the current requirements of IPC/JEDEC J-STD-020.
- ▶ Suitable for use in SnPb or Pb-free soldering processes.

Features

- **High Efficiency 5A, 1.5MHz Switching Charger with Output Inductor DFE252012F, TOKO**
 - ▶ Charging Efficiency 90.25% at ICHG = 2A
 - ▶ Charging Efficiency 88.86% at ICHG = 3A
 - ▶ Charging Efficiency 84.2% at ICHG = 5A
- **Synchronous 1.5MHz/0.75MHz Fixed-Frequency PWM Controller with Up to 95% Duty Cycle**
- **Power Path Management by BATFET Control**
- **Support High Voltage Input (9V/12V)**
- **Support High Voltage Input Adapter (Pump Express 1.0/2.0)**
- **Support IR Compensation Function from Charger Output to Cell Terminal**
- **Optimize Input Sourcing Capability to Prevent Overload**
 - ▶ AICR Current Limit Setting via I²C
 - ▶ ILIM Pin for Current Limit Setting
 - ▶ Average Input Current Limit Measurement
- **Shipping Mode for Battery Leakage Reduction**
 - ▶ Wake Up System, Exit Shipping Mode, and Reset System by QON Pin
- **Automatic Charging**
- **Average Input Current Regulation (AICR) : 0.1A to 3.25A in 50mA Steps**
- **Charge Current Regulation Accuracy : ±7%**
- **Charge Voltage Regulation Accuracy : ±1% (0 to 85°C)**
- **Protection for Overall System Considerations**
 - ▶ Thermal Regulation for Current Reduction and Over-Temperature Protection
 - ▶ Input Over-Voltage Protection
 - ▶ Input Bad Adapter Protection
 - ▶ Battery Over-Voltage Protection
- **Support ADC Conversion for**
 - ▶ VBUS, VBAT, VSYS, REGN, TS_BAT, IBUS, IBAT, TEMP_JC
- **INT Output for Communication with Host Through I²C (Watch Dog / Polling Function)**

Marking Information

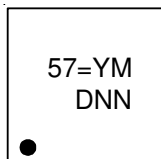

57= : Product Code
YMDNN : Date Code

Pin Configuration

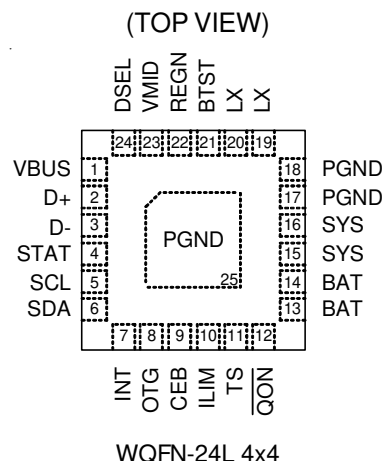

Typical Application Circuit

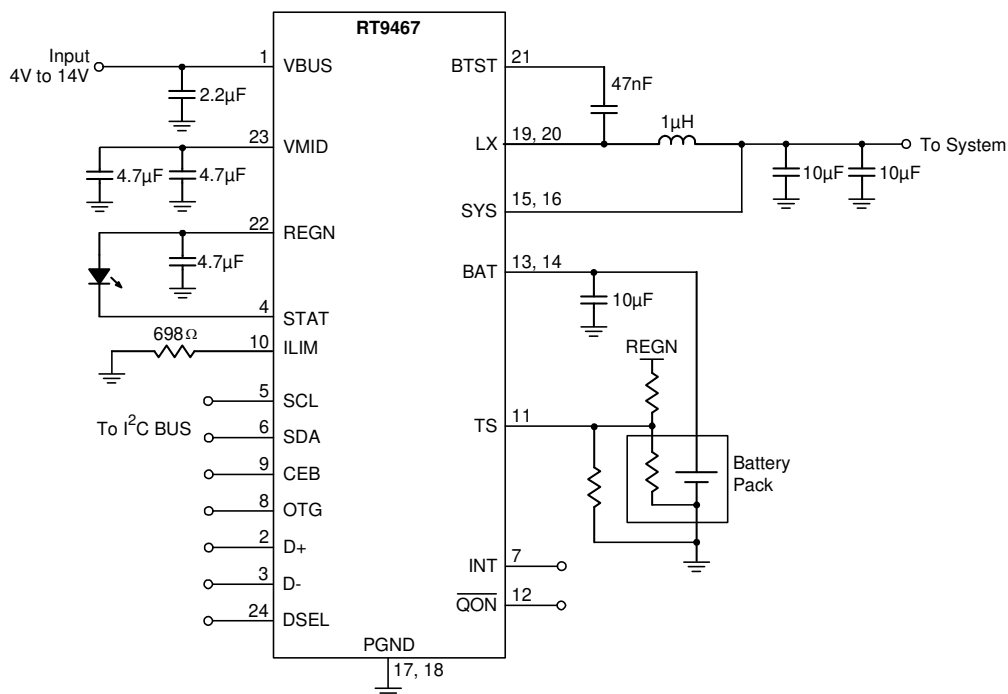

Below are recommended components information

Pin	Description	Part Number	Package	Manufacturer
VBUS	2.2µF/25V/X5R	GRM155R61E225KE11	0402	muRata
VMID	4.7µF/25V/X5R	GRM188R61E475KE11	0603	muRata
BTST	47nF/16V/X5R	GRM033R61C473KE84	0201	muRata
SYS	10µF/6.3V/X5R	GRM185R60J106ME15	0603	muRata
BAT	10µF/6.3V/X5R	GRM185R60J106ME15	0603	muRata
REGN	4.7µF/6.3V/X5R	GRM155R60J475ME47	0402	muRata
LX	1µH/20%	DFE252012F-1R0	2.5 x 2mm	TOKO
ILIM	698Ω/1%	RR0306S-6980-FNH	0201	CYNTEC

Functional Pin Description

Pin No.	Pin Name	Pin Description
1	VBUS	Power input.
2	D+	USB D+ port.
3	D-	USB D- port.
4	STAT	Charge status indication, open-drain output that indicates charge is in progress when held low and charge is finished when held High. If any fault occurs, CHG_STAT will blink at the frequency of 1Hz. Connect a 2.2k-10kΩ pull-up resistor.
5	SCL	I ² C interface serial clock input. Open-drain. An external pull-up resistor is required.
6	SDA	I ² C interface serial data input/output. Open-drain. An external pull-up resistor is required.
7	INT	Interrupt output, active-low open-drain. Indicator of the charger/Boost event for system processor.
8	OTG	OTG boost mode enable control, active-high. Act with OTG_PIN_EN (Addr0x01[1]). (Internal pull down 102kΩ)
9	CEB	Charger enable input, active-low. (Internal pull down 102kΩ)
10	ILIM	Input current limit setting pin. A resistor is connected from ILIM pin to ground to set the maximum input current limit. The actual input current limit is the lower value set through the ILIM pin and IAICR register bits.
11	TS	Battery temperature-sense input, connected to a resistor divider for temperature programming. If there is no need for the battery temperature-sense function, a 50kΩ resistor is connected to REGN and another 50kΩ resistor to ground.
12	\overline{QON}	Internal BATFET enable control input. In shipping mode, \overline{QON} is pulled Low for the duration of t _{SHIPMODE} (typical 0.9s) to exit shipping mode.
13, 14	BAT	Charge current output node for battery connection. The internal BATFET is connected between VSYS and BAT. Connect a 10μF ceramic capacitor between BAT and ground.
15, 16	SYS	System connection node. The internal BATFET is connected between SYS and BAT. Connect a 20μF ceramic capacitor between SYS and ground.
17, 18	PGND	Power ground.
19, 20	LX	Switch node for output inductor connection.
21	BTST	Bootstrap capacitor connection for high-side gate driver. Connect a capacitor from BTST to LX to power the internal gate driver.
22	REGN	Regulated output voltage to supply for the PWM low-side gate driver and the bootstrap capacitor. Connect a 4.7μF ceramic capacitor from REGN to GND. 1. If VBUS is plugged in, REGN will be powered by VBUS and regulated to 4.9V. 2. If VBUS is unplugged, the charger will operate in sleep mode and the REGN voltage will be 0V. * For #2. : Since the REGN voltage is also used to power the TS resistor, when the charger is in sleep mode, the REGN will be woken up (be reactivated) if VBAT is greater than forward voltage (V _F) of the internal high-side(HS) MOS diode by V _{SLEEP_EXIT} with all function of the internal ADC being activated and I ² C R/W. The REGN wake-up time is 500ms.

Pin No.	Pin Name	Pin Description
23	VMID	Connection point between the reverse blocking MOSFET and the high-side switching MOSFET.
24	DSEL	1. Open drain type configuration 2. During input source type detection, the pin drives low. 3. When detection is completed, the pin keeps low. (DCP / HVDCP) 4. When detection is completed, the pin keeps high. (The other type source detection, SDP /CDP)
25 (Exposed Pad)	PGND	Power ground. The exposed pad must be connected to GND and well soldered to a large PCB copper area for maximum power dissipation.

Functional Block Diagram

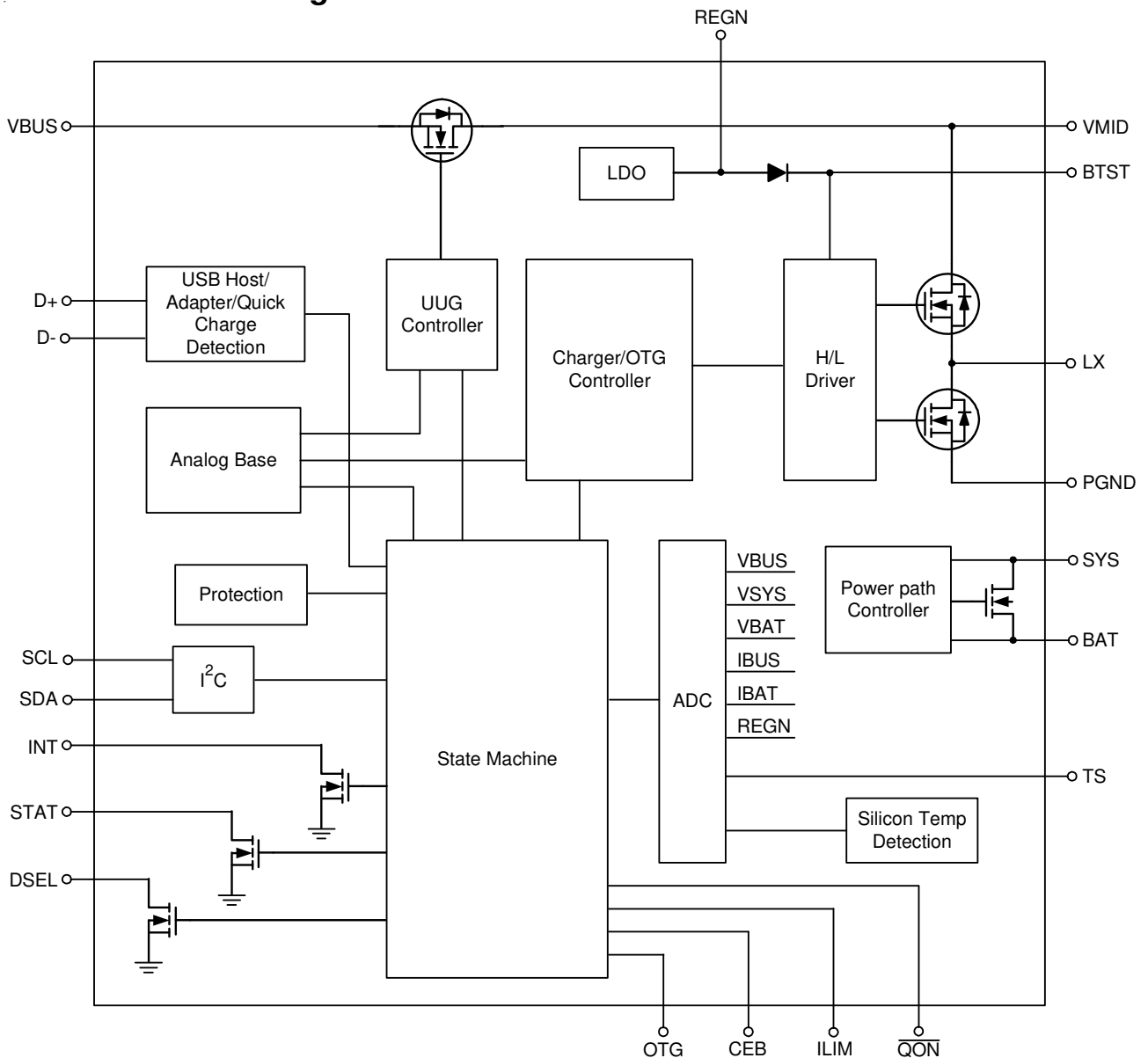

Operation

The RT9467 is an integrated single cell Li-ion battery switching charger with power path controller.

Base Circuits

Base circuits provide the internal power, VREGN and reference voltage and bias current.

Protection Circuits

The protection circuits include the VINOVP, VINUVLO, BATOVP and OTP circuits. The protection circuits turn off the charging when the input power or die temperature is in abnormal level.

Buck Regulator for Charging and Boost Regulator

as OTG

The multi-loop controller controls the operation of charging process and current supply to the system. It also controls the circuits as a Boost converter for OTG applications.

Battery Detection

The RT9467 is capable of doing the battery absence detection. The detection protects the charger when battery is removed accidentally.

Adapter Detection

If the poor input power source is connected to the RT9467, the operation will be shut down by the adapter detection.

Power Path Management and Control

Once the battery voltage increases to a defined system minimum regulation voltage, the internal path between SYS and BAT will be fully turned on. That is, a better charging efficiency can be achieved. When end of charge occurs, the charging will stop and the internal path will be turned off.

USB Charger Detection

The RT9467 can detect and distinguish Standard Downstream Port, Charging Downstream Port and Dedicated Charging Port via DP and DM pins.

TS Detection

The RT9467 detects the temperature of the battery pack via REGN and TS pins. The REGN pin provides a constant voltage source to drive the voltage divider composed of a pulled-high resistor and a NTC resistor. The RT9467 reports the sensing results via IRQ and status bits for COLD, COOL, WARM and HOT.

I²C Controller

The key parameters of charging and OTG are programmable through I²C commands.

Absolute Maximum Ratings (Note 1)

• Supply Input Voltage, V _{BUS} -----	-0.3V to 22V
• Supply Input Voltage, V _{BUS} (Peak <100ns duration) -----	-2V
• VMID, BTST -----	-0.3V to 22V
• LX -----	-0.3V to 16V
• LX (Peak <100ns duration) -----	-2V
• VMID – V _{BUS} , BTST – LX -----	-0.3V to 6V
• Other Pins -----	-0.3V to 6V
• Power Dissipation, P _D @ T _A = 25°C	
WQFN-24L 4x4 -----	4.54W
• Package Thermal Resistance (Note 2)	
WQFN-24L 4x4, θ _{JA} -----	22°C/W
WQFN-24L 4x4, θ _{JC} -----	5.4°C/W
• Lead Temperature (Soldering, 10 sec.) -----	260°C
• Junction Temperature -----	150°C
• Storage Temperature Range -----	-65°C to 150°C
• ESD Susceptibility (Note 3)	
HBM (Human Body Model) -----	2kV

Recommended Operating Conditions (Note 4)

• Supply Input Voltage -----	4V to 14V
• Maximum Input Current (V _{BUS}), I _{AICR} -----	3.25A
• Maximum SYS Output Current (SW), I _{SYS} -----	5A
• Maximum Battery Voltage, V _{BAT} -----	4.71V
• Maximum I _{BAT} Fast Charging Current -----	5A
• Maximum I _{BAT} Discharging Current -----	6A
• Maximum I _{BAT} Discharging Current peak, 1sec duration -----	9A
• Junction Temperature Range -----	-40°C to 125°C
• Ambient Temperature Range -----	-40°C to 85°C

Electrical Characteristics

(V_{BUS} = 5V, V_{BAT} = 4.2V, L = 1μH, C_{IN} = 2.2μF, C_{BATS} = 10μF, T_A = 25°C, unless otherwise specified)

Parameter	Symbol	Test Conditions	Min	Typ	Max	Unit
Quiescent Current						
V _{BUS} Supply Current	I _{VBUS_SW}	V _{LX} is switching, V _{BUS} = 5V, V _{SYS} = 3.8V	--	8	--	mA
	I _{VBUS_NON_SW}	V _{LX} is non-switching, V _{BUS} = 5V, V _{SYS} = 4.4V	--	--	5	mA
	I _{VBUS_HZ}	V _{LX} is in high-impedance mode, V _{BUS} = 5V, V _{SYS} = 3.8V	--	--	170	μA
Battery Leakage Current	I _{BAT_LEAK_OFF}	V _{BAT} = 4.2V, power path is off	--	--	25	μA
	I _{BAT_LEAK_ON}	V _{BAT} = 4.2V, SCL & SDA pull low, no V _{BUS} .	--	--	60	

Parameter	Symbol	Test Conditions	Min	Typ	Max	Unit
Boost-Mode Battery Discharge Current	IBAT_BOOST_SW	V _{BAT} = 4.2V, boost mode, I _{VBUS} = 0A, V _{LX} is switching	--	5	--	mA
V_{BUS} / V_{BAT} Power-Up						
Sleep-Mode Entry Threshold, V _{BUS} -V _{BAT}	V _{SLEEP_ENTER}	2.5V < V _{BAT} < V _{OREG} , V _{BUS} falling	0	40	100	mV
Sleep-Mode Exit Threshold, V _{BUS} -V _{BAT}	V _{SLEEP_EXIT}	2.5V < V _{BAT} < V _{OREG} , V _{BUS} rising	40	100	200	mV
Sleep-Mode Exit Deglitch Time	t _{D_SLEEP_EXIT}	Exit sleep-mode	--	120	--	ms
V _{BUS} Bad Adapter Threshold	V _{BAD_ADP}		--	3.8	--	V
V _{BUS} Bad Adapter Hysteresis	V _{BAD_ADP_HYS}		--	150	--	mV
V _{BUS} Bad Adapter Sink Current	I _{BAD_ADP_SINK}		--	50	--	mA
V _{BUS} Bad Adapter Detection Time	t _{BAD_ADP_DET}		--	30	--	ms
Input Current Limit Factor	K _{ILIM}	Input current regulation 508mA by ILIM pin with resistance = 698Ω	320	355	390	AΩ
Input Current Limit Regulation	I _{ILIM_MIN}	Minimum input current for regulation on ILIM pin	0.5	--	--	A
Input Power Regulation						
Minimum Input Voltage Regulation (MIVR) Threshold Range	V _{MIVR}	I ² C programmable in 0.1V steps	3.9	--	13.4	V
Default Minimum Input Voltage Regulation Threshold	V _{MIVR_DEF}	Default	--	4.4	--	V
Minimum Input Voltage Regulation Accuracy	V _{MIVR_ACC}	V _{MIVR} = 4.4V, 9V	-3	--	3	%
Average Input Current Regulation Accuracy	I _{AICR_ACC}	USB charge mode, I _{AICR} = 100mA	86	93	100	mA
		USB charge mode, I _{AICR} = 500mA	440	470	500	
		USB charge mode, I _{AICR} = 1000mA	880	940	1000	
		Adapter 1.5A charge mode, I _{AICR} = 1500mA	1300	1400	1500	
Protection						
V_{BUS}						
V _{BUS} Under-Voltage Protection Threshold	V _{UVLO}	V _{BUS} rising	3.05	3.3	3.55	V
V _{BUS} Under-Voltage Protection Hysteresis	V _{UVLO_HYS}	V _{BUS} falling from UVLO	--	150	--	mV

Parameter	Symbol	Test Conditions	Min	Typ	Max	Unit
VBUS Over-Voltage Protection Threshold	V _{BUS_OVP}	VBUS rising	14	14.5	15	V
VBUS Over-Voltage Protection Hysteresis	V _{BUS_OVP_HYS}	VBUS falling	--	250	--	mV
VBAT						
Battery Over-Voltage Protection Threshold	V _{BAT_OVP}	VBAT rising, as percentage of V _{OREG} , as (V _{BAT_OVP} -V _{OREG})/V _{OREG}	106	108	110	%
Battery Over-Voltage Protection Hysteresis	V _{BAT_OVP_HYS}	VBAT falling, as (V _{BAT_OVP_HYS})/V _{OREG}	--	4	--	%
Thermal Protection						
Over-Temperature Protection Threshold	T _{OTP}	Thermal shutdown threshold temperature	--	160	--	°C
Over-Temperature Protection Hysteresis	T _{OTP_HYS}	Thermal shutdown hysteresis temperature	--	30	--	°C
Thermal Regulation Threshold	T _{TR}	Charge current starts decreasing	--	120	--	°C
V_{sys}						
V _{sys} Over-Voltage Protection Threshold	V _{sys_OVP}	V _{sys} rising	--	5.25	--	V
V _{sys} Under-Voltage Protection Threshold	V _{sys_UVP}	V _{sys} falling	--	2.4	--	V
Battery Charging Stages						
End of Charge						
Regulated Battery Voltage Range	V _{OREG}	I ² C programmable in 10mV steps	3.9	--	4.71	V
Regulated Battery Voltage	V _{OREG_DEF}	Default	--	4.2	--	V
Regulated Battery Voltage Accuracy	V _{OREG_ACC}	Temperature = 0 to 85°C	-1	--	1	%
Re-Charge Mode Threshold	V _{RECH}	VBAT falling, the difference below V _{OREG} , (Addr 0x0B[2:0] = 00)	50	100	150	mV
Re-Charge Deglitch Time	t _{D_RECH}		--	120	--	ms
End-of-Charge Current	I _{EOC}	I ² C programmable in 50mA steps	100	--	850	mA
Default End-of-Charge Current	I _{EOC_DEF}	Default	--	250	--	mA
End-of-Charge Current Accuracy	I _{EOC_ACC}		-20	--	20	%
Default End-of-Charge Deglitch Time	t _{D_EOC}	Default	--	2	--	ms
Fast Charge						
Charge Current Range	I _{CHG}	I ² C programmable in 0.1A steps	0.1	--	5	A

Parameter	Symbol	Test Conditions	Min	Typ	Max	Unit	
Charge Current Accuracy	I _{CHG_ACC}	V _{BAT} = 3.8V	I _{CHG} < 500mA	-20	--	20	%
			500mA < I _{CHG} < 1000mA	-10	--	10	
			I _{CHG} > 1000mA	-7	--	7	
Pre-Charge							
Pre-Charge Mode Threshold	V _{PRECHG}	I ² C programmable in 0.1V steps	2	--	3.5	V	
Pre-Charge Mode Hysteresis	V _{PRECHG_HYS}	Pre-charge hysteresis, falling	--	0.2	--	V	
Pre-Charge Mode Threshold Accuracy	V _{PRECHG_ACC}		-5	--	5	%	
Pre-Charge Current Range	I _{PRECHG}	I ² C programmable in 50mA steps	100	--	850	mA	
Default Pre-Charge Current	I _{PRECHG_DEF}	Default	--	150	--	mA	
Pre-Charge Current Accuracy	I _{PREC_ACC}		-20	--	20	%	
Trickle Charge							
Trickle Charge Threshold	V _{TRICHG}	V _{BAT} falling	--	2	--	V	
Trickle Charge Threshold Hysteresis	V _{TRICHG_HYS}	V _{BAT} rising	--	200	--	mV	
Trickle Charge Threshold Accuracy	V _{TRICHG_ACC}		-5	--	5	%	
Trickle Current	I _{TRICHG}	V _{BAT} < 2V, charge with ICC = 100mA V _{BAT} < 1.6V, charge with AICR = 100mA	--	100	--	mA	
Trickle Current Accuracy	I _{TRICHG_ACC}		-20	--	20	%	
V_{sys}							
System Regulation Voltage	V _{sysREG}	Minimum system regulation voltage, I ² C programmable in 0.1V steps	3.3	--	4	V	
Default System Regulation Voltage	V _{sysREG_DEF}	Default minimum system regulation voltage	--	3.6	--	V	
System Regulation Accuracy	V _{sysREG_ACC}		-5	--	5	%	
Battery Charger							
UUG On-Resistance	R _{ON_UUG}	From V _{BUS} to V _{MID}	--	17	32	mΩ	
High-Side On-Resistance	R _{ON_UUG_UG}	From V _{BUS} to LX	--	42	79	mΩ	
Low-Side On-Resistance	R _{ON_LG}	From LX to PGND	--	28	40	mΩ	
Power-Path-Side On-Resistance	R _{ON_PPMOS}	From SYS to BAT	--	13	30	mΩ	
Switching Frequency (1.5MHz)	f _{OSC1}	I ² C programmable to 1.5 MHz (Addr 0x01[7] =0)	--	1.5	--	MHz	

Parameter	Symbol	Test Conditions	Min	Typ	Max	Unit
Switching Frequency (750kHz)	f _{OSC2}	I ² C programmable to 0.75MHz (Addr 0x01[7] =1)	--	0.75	--	MHz
Frequency Accuracy	f _{OSC_ACC}		-10	--	10	%
Maximum Duty Cycle	D _{MAX}	At minimum input voltage	--	97	--	%
Minimum Duty Cycle	D _{MIN}		0	--	--	%
REGN Regulation	V _{REGN}	V _{BUS} = 5V / 9V / 12V	--	4.9	--	V
REGN Current Limit	I _{LIM_REGN}	V _{BUS} = 5V / 9V / 12V	50	--	--	mA
Sink Current for Battery Detection	I _{BAT_SINK}		--	300	--	μA
Internal QON Pull-Up Resistance	R _{QON}		--	200	--	kΩ
Internal QON Pull-Up	V _{QON}	Battery only	--	V _{BAT}	--	V
		V _{BUS} = 5V/9V	--	4.8	--	
QON Exit Shipping Mode Time	t _{SHIPMODE}	QON Low for BATFET on-time to exit shipping mode	--	0.9	--	sec
System Reset by QON Pin	t _{QON_RST}	QON low time to enable full system reset	--	10	--	sec
BATFET Reset Time	t _{BATFET_RST}	BATFET off-time during full system reset	--	0.41	--	sec
Shipping Mode Entry Deglitch Time	t _{D_SM_ENTER}	Enter shipping mode	--	9	--	sec
AICL	V _{AICL}	V _{BUS} rising, I ² C programmable	--	4.6	--	V
AICL Hysteresis	V _{AICL_HYS}		--	50	--	mV
Inductor Over-Current Protection Buck Threshold	I _{OCP_BUCK}	Inductor OCP level for buck mode	--	6	--	A
OTG Boost Mode Operation						
OTG Boost-Mode Output Regulation Voltage Range	V _{OTGBST}	To V _{BUS}	4.425	--	5.825	V
OTG Boost-Mode Output Regulation Voltage Accuracy	V _{OTGBST_ACC}		-3	--	3	%
OTG Boost-Mode Over-Load Protection Threshold	I _{OTG_OLP}	I ² C programmable	0.5	--	2.4	A
OTG Boost-Mode Default Over-Load Protection Threshold	I _{OTG_OLP_DEF}	Addr 0x0A [2:0] = 000	0.5	--	--	A
OTG Low Battery Protection Threshold	V _{OTG_LBP}	I ² C programmable, hysteresis = 0.4 V	2.3	--	3.8	V
OTG Default Low Battery Protection Threshold	V _{OTG_LBP_DEF}	OTG_LBP = 2.8V (Addr0x0A[7:4] = 0101)	--	2.8	--	V

Parameter	Symbol	Test Conditions	Min	Typ	Max	Unit
OTG Low Battery Protection Threshold Accuracy			-5	--	5	%
OTG VMID Over-Voltage Protection	VOTG_VMID_OVP	VVMID rising	--	6	--	V
OTG VMID Over-Voltage Protection Hysteresis	VOTG_VMID_OVP_HYS		--	200	--	mV
Inductor Over-Current Protection Boost Threshold	IOCP_BOOST	Inductor OCP level for boost mode	--	5.5	--	A
Current Pulse Control, PE1.0						
Current Pulse Control Stop Pulse	tPUMPX_STOP		430	--	570	ms
Current Pulse Control Long On Pulse	tPUMPX_ON1		240	--	360	ms
Current Pulse Control Short On Pulse	tPUMPX_ON2		70	--	130	ms
Current Pulse Control Off Pulse	tPUMPX_OFF		70	--	130	ms
Current Pulse Control Short On Pulse	tPUMPX_ON2		70	--	130	ms
Current Pulse Control Off Pulse	tPUMPX_OFF		70	--	130	ms
Current Pulse Control Stop Start Delay	tPUMPX_DLY		80	--	225	ms
I²C Characteristics						
Output Low Threshold Voltage	V _{OL} I ² C	I _{DS} = 10mA	--	--	0.4	V
SCL, SDA Input Logic High Threshold Voltage	V _{IH} I ² C		1.3	--	--	V
SCL, SDA Input Logic Low Threshold Voltage	V _{IL} I ² C		--	--	0.4	V
SCL Clock	f _{SCL}		--	--	400	kHz
High Level Leakage Current	I _{BIRS}	V _{PULL_UP} = 1.8V, SDA and SCL	--	--	1	μA
Load Capacitance	C _{LOAD}	V _{PULL_UP} = 1.8V	--	--	1	pF
Default Wait Time for Watch Dog Reset	t _{WDT_DEF}	Watch Dog timer selection, Default : 0x0D[6] = 1	--	500	--	ms
NTC Monitor						
Battery Temperature HOT Threshold	V _{VTS_HOT}	V _{TS} falling, the ratio of V _{REGN}	33.5	34.5	35.5	%
Battery Temperature WARM Threshold	V _{VTS_WARM}	V _{TS} falling, the ratio of V _{REGN}	44	45	46	%

Parameter	Symbol	Test Conditions	Min	Typ	Max	Unit
Battery Temperature COOL Threshold	VVTS_COOL	V _{TS} rising, the ratio of V _{REGN}	67.5	68.5	69.5	%
Battery Temperature COLD Threshold	VVTS_COLD	V _{TS} rising, the ratio of V _{REGN}	72.5	73.5	74.5	%
Battery Temperature Hysteresis	VVTS_HYS		--	2	--	%
Control I/O Pin (STAT, INT)						
Output Low Voltage	V _{OL_CTRL}	I _{DS} = 10mA	--	--	0.4	V
Control I/O Pin (OTG, CEB, QON)						
Input Threshold Voltage	V _{IH_CTRL}	Logic high threshold	1.3	--	--	V
	V _{IL_CTRL}	Logic low threshold	--	--	0.4	
Battery Charge Detection Spec (D+/D-)						
VDP_SRC Voltage	VDP_SRC	With I _{DAT_SRC} = 0 to 250μA	0.5	0.65	0.7	V
V _{DAT_REF} Voltage	V _{DAT_REF}		0.25	0.325	0.4	V
VLGC Voltage	V _{LGC}		0.8	1.2	2	V
IDM SINK Current	I _{DM_SINK}	May be a resistance if desired	50	100	150	μA
Data Contact Timeout	t _{DCDT}	Setting by register 0x12[5:4]	--	600	--	ms
ADC						
ADC Conversion Time each Channel	t _{CONV}		35	200	--	ms
Number of Bits for ADC Resolution	RES	Logic high threshold	--	10	--	bit
ADC Accuracy and Measurement Range						
VBUS_DIV5 Measurement Range	V _{VBUS_DIV5ADC_RANGE}		1	--	22	V
VBUS_DIV5 Resolution	V _{VBUS_DIV5ADC_RES}		--	25	--	mV
VBUS_DIV5 Accuracy	V _{VBUS_DIV5ADC_ACC}		-2	--	2	LSB
VBUS_DIV2 Measurement Range	V _{VBUS_DIV2ADC_RANGE}		1	--	9.8	V
VBUS_DIV2 Resolution	V _{VBUS_DIV2ADC_RES}		--	10	--	mV
VBUS_DIV2 Accuracy	V _{VBUS_DIV2ADC_ACC}		-2	--	2	LSB
VBAT Measurement Range	V _{VBAT_ADC_RANGE}		0	--	4.9	V
VBAT Resolution	V _{VBAT_ADC_RES}		--	5	--	mV
VBAT Accuracy	V _{VBAT_ADC_ACC}		-2	--	2	LSB
V _{SYS} Measurement Range	V _{VSYS_ADC_RANGE}		0	--	4.9	V
V _{SYS} Resolution	V _{VSYS_ADC_RES}		--	5	--	mV

Parameter	Symbol	Test Conditions	Min	Typ	Max	Unit
VSYS Accuracy	V _{VSYS} ADC_ACC		-2	--	2	LSB
REGN Measurement Range	V _{REGN} ADC_Range		0	--	4.9	V
REGN Resolution	V _{REGN} ADC_RES		--	5	--	mV
REGN Accuracy	V _{REGN} ADC_ACC		-2	--	2	LSB
TS_BAT Measurement Range	Rate _{TS_BAT}		0	--	100	%
TS_BAT Resolution	Rate _{TS_BAT} RES		--	0.25	--	%
TS_BAT Accuracy	Rate _{TS_BAT} ACC		-2	--	2	LSB
IBUS Measurement Range	I _{IBAT} ADC_Range		0	--	3.25	A
IBUS Resolution	I _{IBAT} ADC_RES		--	50	--	mA
IBUS Accuracy	I _{IBAT} ADC_ACC		-2	--	2	LSB
IBAT Measurement Range	I _{IBAT} ADC_Range		0	--	5	A
IBAT Resolution	I _{IBAT} ADC_RES		--	50	--	mA
IBAT Accuracy	I _{IBAT} ADC_ACC		-2	--	2	LSB
TEMP_JC Measurement Range	T _{TEMP_JC} ADC_Range		-40	--	120	°C
TEMP_JC Resolution	T _{TEMP_JC} ADC_RES		--	2	--	°C
TEMP_JC Accuracy	T _{TEMP_JC} ADC_ACC	Temperature < 85°C	-2	--	2	LSB

Note 1. Stresses beyond those listed “Absolute Maximum Ratings” may cause permanent damage to the device. These are stress ratings only, and functional operation of the device at these or any other conditions beyond those indicated in the operational sections of the specifications is not implied. Exposure to absolute maximum rating conditions may affect device reliability.

Note 2. θ_{JA} is measured in the natural convection at $T_A = 25^\circ\text{C}$ on a Four-layer Richtek Evaluation Board. θ_{JC} is measured at the Top of the package.

Note 3. Devices are ESD sensitive. Handling precaution is recommended.

Note 4. The device is not guaranteed to function outside its operating conditions.

Typical Operating Characteristics

Charger Efficiency vs. Charging Current

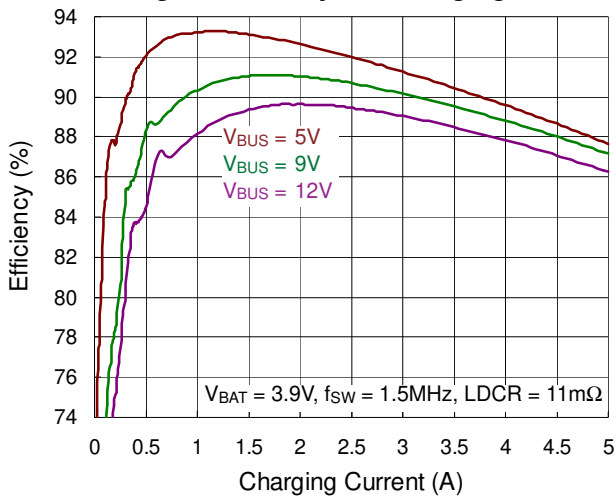

Charger Efficiency vs. Charging Current

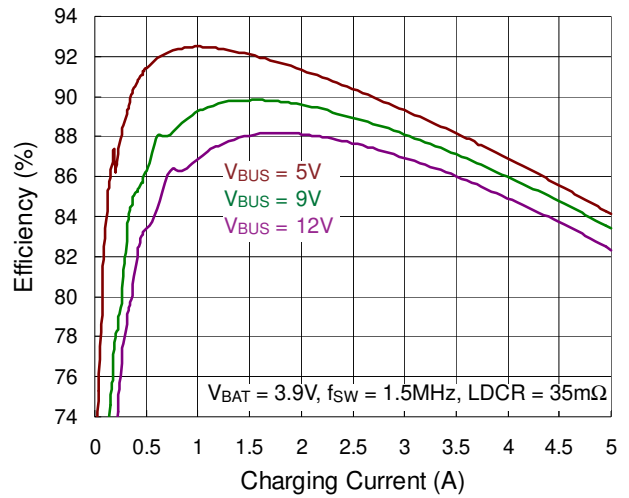

Charger Efficiency vs. Charging Current

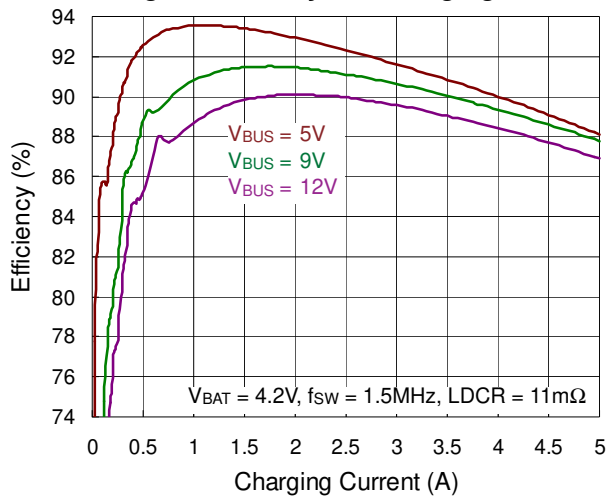

Charger Efficiency vs. Charging Current

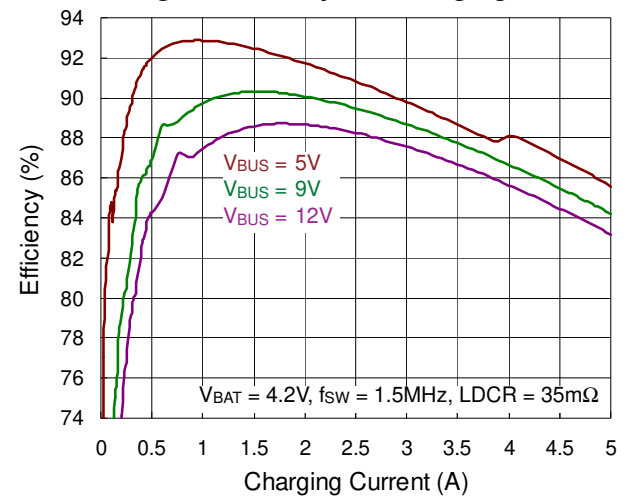

Boost Efficiency vs. Load Current

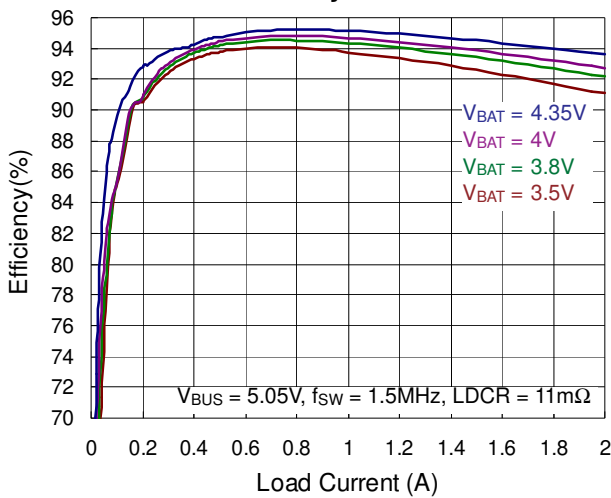

Boost Efficiency vs. Load Current

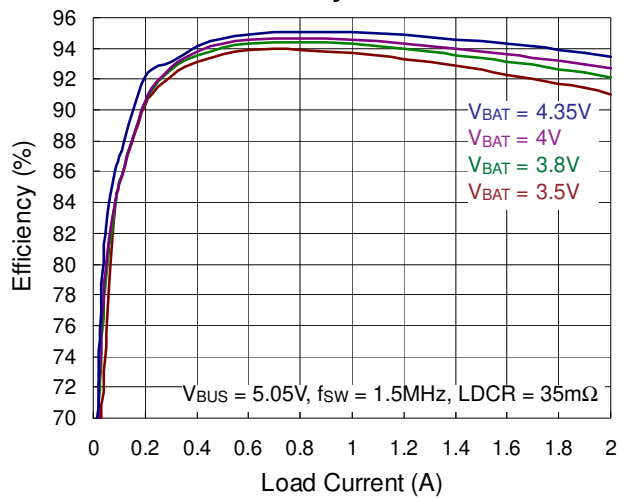

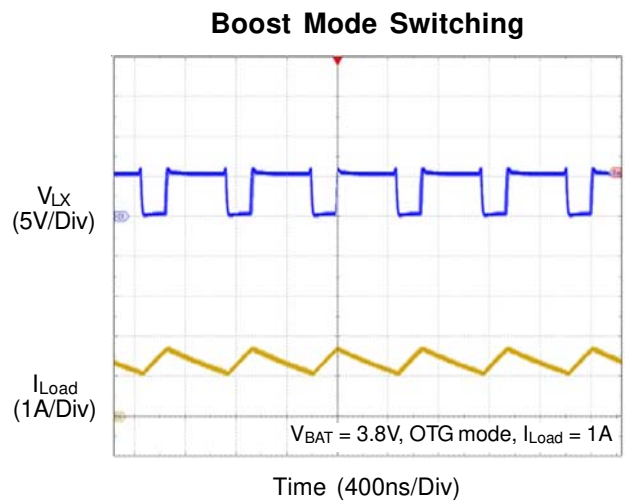
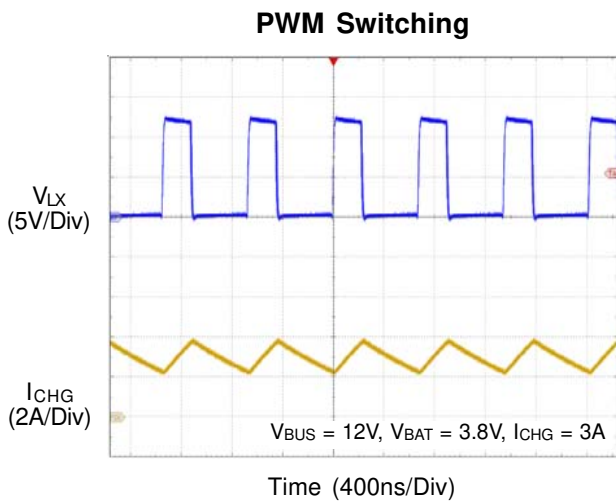
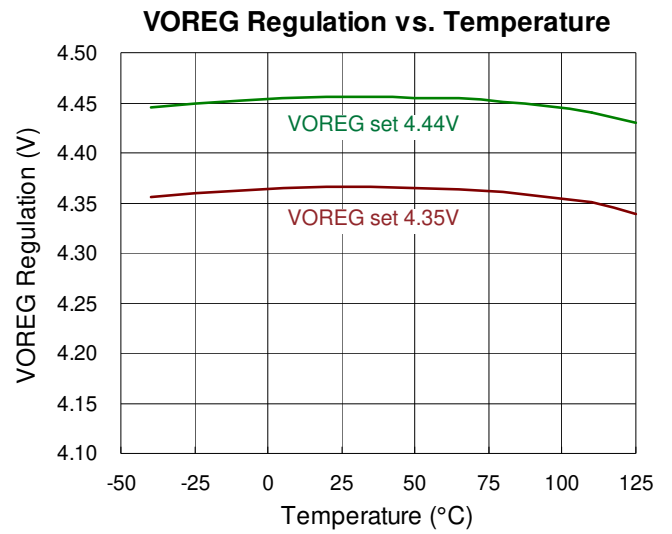
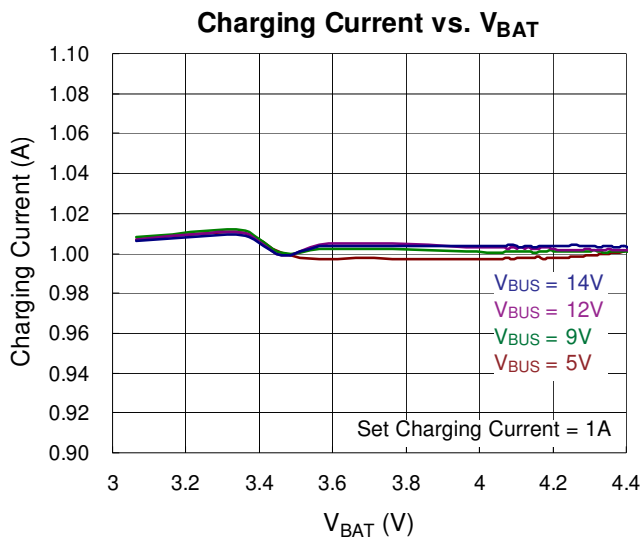

Register Description

I²C Slave Address : 1011011 (5BH)

Name		Function	Addr	Reset
CORE_CTRL0		Control 0	0x00	0x00
Bit	Mode	Name	Reset Value	Description
7	R/W	RST_REG	0	All registers reset bit. 0: Don't reset all registers. 1: Reset all registers. (Notice: 1. This bit will be reset to "0" after reset procedure finish. 2. In high-impedance mode, this bit reset all registers after leave high-impedance mode.)
[6:0]	R/W	Reversed	0000000	Reversed

Name		Function	Addr	Reset
CHG_CTRL1		Control 1	0x01	0x10
Bit	Mode	Name	Reset Value	Description
7	R/W	SEL_SWFREQ	0	The switching frequency selection bit (Charger/OTG) 0 : The switching frequency is 1.5MHz. (Default) 1 : The switching frequency is 0.75MHz.
6	R/W	FIXFREQ	0	Charger switching frequency 0 : Charger switching frequency would be varied if VBUS is closed to VBAT(default) 1 : Charger switching frequency is fixed
5	R/W	Reversed	0	Reversed
4	R/W	STAT_EN	1	Charger STAT pin function 0 : Disable 1 : Enable (default)
3	R/W	IRQ_PULSE	0	IRQ reminder function 0 : IRQ reminder is disabled (default) 1 : IRQ reminder is enabled. If IRQ is triggered but no check action, INT pin will be released as well as being triggered again with every 2s intervals
2	R/W	HZ	0	High-impedance selection 0 : No high-impedance mode (default) 1 : High-impedance mode
1	R/W	OTG_PIN_EN	0	Boost mode enable with OTG pin 0 : Enable Boost mode by OPA_MODE (default) 1 : Enable Boost by both OPA_MODE bit and OTG pin
0	R/W	OPA_MODE	0	Boost mode enable 0 : Charge mode (default) 1 : Boost mode for OTG

Name		Function	Addr	Reset
CHG_CTRL2		Charger Control 2	0x02	0x03
Bit	Mode	Name	Reset Value	Description
7	R/W	SHIP_MODE	0	Shipping mode enable, force BATFET OFF 0 : Allow BATFET turn on (default) 1 : Force BATFET turn off
6	R/W	BATDET_DIS_DLY	0	BATFET turn off delay 0 : BATFET turn off immediately (default) 1 : BATFET turn off with 10s delay after SHIP_MODE bit is set
5	R/W	Reserved	0	Reserved
4	R/W	TE	0	Termination enable 0 : Disable charge current termination (default) 1 : Enable charge current termination
[3:2]	R/W	IINLMTSEL	00	Input current limit selection bit 00 : Input limit is set as 3.25A (default) 01 : CHG_TYP results is applied D+D- detection 10 : IAICR[5:0] results is applied 11 : Input limit is set by the lower level of these three
1	R/W	CFO_EN	1	Charger and OTG enable 0 : Charger and OTG disable 1 : Charger and OTG enable (default)
0	R/W	CHG_EN	1	Charger enable 0 : Charger is disabled 1 : Charger is enabled (default)

Name		Function	Addr	Reset
CHG_CTRL3		Control 3	0x03	0x23
Bit	Mode	Name	Reset Value	Description
[7:2]	R/W	IAICR[5:0]	001000	AICR setting 000000 : 100mA 000001 : 150mA 000010 : 200mA 000011 : 250mA ... 001000 : 500mA (default) 001001 : 550mA ... 100110 : 2A ... 111010 : 3A ... 111111 : 3.25A
1	R/W	AICR_EN	1	AICR loop enable 0 : AICR loop disable 1 : AICR loop enable (default)
0	R/W	ILIM_EN	1	ILIM function enable 0 : ILIM function disable 1 : ILIM function enable (default)

Name		Function	Addr	Reset
CHG_CTRL4		Control 4	0x04	0x3C
Bit	Mode	Name	Reset Value	Description
[7:1]	R/W	VOREG[6:0]	0011110	Battery regulation voltage. The delta-V of the Battery regulation voltage is 10mV. 0000000 : 3.9V 0000001 : 3.91V 0000010 : 3.92V 0000011 : 3.93V ... 0011101 : 4.19V 0011110 : 4.2V (default) 0011111 : 4.21V ... 0101100 : 4.34V 0101101 : 4.35V 0101110 : 4.36V ... 1010001 : 4.71V 1010001 to 1111111 : 4.71V
0	R/W	Reserved	0	Reserved

Name		Function	Addr	Reset
CHG_CTRL5		Control 5	0x05	0x67
Bit	Mode	Name	Reset Value	Description
[7:2]	R/W	VOTGBST[5:0]	011001	OTG boost-mode output regulation voltage. The delta-V of the OTG regulation voltage is 25mV. 000000 : 4.425V 000001 : 4.45V 000010 : 4.475V ... 010111 : 5V 011000 : 5.025V 011001 : 5.05V (default) 011010 : 5.075V 011011 : 5.1V ... 111000 : 5.825V 111001 to 111111 : 5.825V
[1:0]	R/W	THREG[1:0]	11	Charger thermal regulation threshold 00 : 60°C 01 : 80°C 10 : 100°C 11 : 120°C (default)

Name		Function	Addr	Reset
CHG_CTRL6		Control 6	0x06	0x0B
Bit	Mode	Name	Reset Value	Description
[7:1]	R/W	VMIVR[6:0]	0000101	Input MIVR threshold setting 0000000 : 3.9V 0000001 : 4V 0000010 : 4.1V 0000011 : 4.2V 0000100 : 4.3V 0000101 : 4.4V (default) 0000110 : 4.5V ... 0011110 : 6.9V 0011111 : 7V ... 0110010 : 8.9V 0110011 : 9V ... 1010000 : 11.9V 1010001 : 12V ... 1011111 : 13.4V 1100000 to 1111111 : 13.4V
0	R/W	MIVR_EN	1	MIVR loop enable 0 : MIVR loop disable 1 : MIVR loop enable (default)

Name		Function	Addr	Reset
CHG_CTRL7		Control 7	0x07	0x4C
Bit	Mode	Name	Reset Value	Description
[7:2]	R/W	ICHG[5:0]	010011	Charging regulation current 000000 : 0.1A 000001 : 0.2A 000010 : 0.3A ... 001000 : 0.9A 001001 : 1A 001010 : 1.1A ... 010010 : 1.9A 010011 : 2A (default) ... 011100 : 2.9A 011101 : 3A ... 100110 : 3.9A 100111 : 4A ... 110000 : 4.9A 110001 : 5A 110010 to 111111 : 5A Note : When ICHG is set above 2.5A, recommend the OCP to set higher level. (Addr 0x0D[2] = 1)
[1:0]	R/W	EOC_TIMER[1:0]	00	EOC back-charging time 00 : 0mins (default) 01 : 30mins 10 : 45mins 11 : 60mins

Name		Function	Addr	Reset
CHG_CTRL8		Control 8	0x08	0xA1
Bit	Mode	Name	Reset Value	Description
[7:4]	R/W	VPREC[3:0]	1010	Pre-Charge voltage threshold 0000 : 2V 0001 : 2.1V 0010 : 2.2V 0011 : 2.3V 0100 : 2.4V 0101 : 2.5V 0110 : 2.6V 0111 : 2.7V 1000 : 2.8V 1001 : 2.9V 1010 : 3.0V (default) 1011 : 3.1V 1100 : 3.2V 1101 : 3.3V 1110 : 3.4V 1111 : 3.5V
[3:0]	R/W	IPREC[3:0]	0001	Pre-Charge current threshold 0000 : 100mA 0001 : 150mA (default) 0010 : 200mA 0011 : 250mA 0100 : 300mA 0101 : 350mA 0110 : 400mA 0111 : 450mA 1000 : 500mA 1001 : 550mA 1010 : 600mA 1011 : 650mA 1100 : 700mA 1101 : 750mA 1110 : 800mA 1111 : 850mA

Name		Function	Addr	Reset
CHG_CTRL9		Control 9	0x09	0x3C
Bit	Mode	Name	Reset Value	Description
[7:4]	R/W	IEOC[3:0]	0011	EOC current setting 0000 : 100mA 0001 : 150mA 0010 : 200mA 0011 : 250mA (default) 0100 : 300mA 0101 : 350mA 0110 : 400mA 0111 : 450mA 1000 : 500mA 1001 : 550mA 1010 : 600mA 1011 : 650mA 1100 : 700mA 1101 : 750mA 1110 : 800mA 1111 : 850mA
3	R/W	EOC_EN	1	IEOC enable/disable 0: Disable 1: Enable (default)
[2:0]	R/W	CHG_TDEG_EOC[2:0]	100	EOC deglitch time 000 : 32μs 001 : 64μs 010 : 128μs 011 : 256μs 100 : 2ms (default) 101 : 4ms 110 : 8ms 111 : 16ms

Name		Function	Addr	Reset
CHG_CTRL10		Control 10	0x0A	0x58
Bit	Mode	Name	Reset Value	Description
[7:4]	R/W	OTG_LBP[3:0]	0101	OTG Low battery protection voltage selection (falling edge threshold, hysteresis voltage = 0.4V) 0000 : 2.3V 0001 : 2.4V 0010 : 2.5V 0011 : 2.6V 0100 : 2.7V 0101 : 2.8V (default) 0110 : 2.9V 0111 : 3.0V 1000 : 3.1V 1001 : 3.2V 1010 : 3.3V 1011 : 3.4V 1100 : 3.5V 1101 : 3.6V 1110 : 3.7V 1111 : 3.8V
3	R/W	OTG_LBP_EN	1	OTG Low battery protection enable/disable 0 : Disable 1 : Enable (default)
[2:0]	R/W	OTG_OLP[2:0]	000	OTG over-load threshold (Minimum) 000 : 0.5A (default) 001 : 0.7A 010 : 1.1A 011 : 1.3A 100 : 1.8A 101 : 2.1A 110 : 2.4A 111 : Reserved Note : When OTG_OLP is set 2.1A or 2.4A, recommend the OCP to set higher level. (Addr 0x0D[2] = 1)

Name		Function	Addr	Reset
CHG_CTRL11		Control 11	0x0B	0x2C
Bit	Mode	Name	Reset Value	Description
7	R/W	ADP_DIS	0	Charger adapter detection disable 0 : Adapter detection is enabled (default) 1 : Adapter detection is disabled
6	R/W	BATD_EN	0	Charger battery detection when charge done 0 : Battery detection is disabled (default) 1 : Battery detection is enabled
5	R/W	SYSUV_HW_SEL	1	System UV protection selection bit 0 : Buck Switching is not turned off when System UVP 1 : Buck Switching is turned off when System UVP (default)
[4:2]	R/W	SYSREG[2:0]	011	Minimum system regulation voltage 000 : 3.3V 001 : 3.4V 010 : 3.5V 011 : 3.6V (default) 100 : 3.7V 101 : 3.8V 110 : 3.9V 111 : 4.0V
[1:0]	R/W	VRECH	00	Charging recharge voltage threshold with VOREG 00 : 100mV (default) 01 : 200mV 10 : 300mV 11 : 400mV

Name		Function	Addr	Reset
CHG_CTRL12		Control 12	0x0C	0x02
Bit	Mode	Name	Reset Value	Description
[7:5]	R/W	WT_FC[2:0]	000	Fast charge Timer 000 : 4hrs (default) 001 : 6hrs 010 : 8hrs 011 : 10hrs 100 : 12hrs 101 : 14hrs 110 : 16hrs 111 : 20hrs
[4:3]	R/W	WT_PRC[1:0]	00	Pre-charge Timer 00 : 30mins (default) 01 : 45mins 10 : 60mins 11 : 60mins
2	R/W	TMR2X_EN	0	Double charger timer during MIVR, AICR, and thermal regulation 0 : Disable 2x extended charger timer (default) 1 : Enable 2x extended charger timer
1	R/W	TMR_EN	1	Charger timer enable/disable 0 : Disable 1 : Enable (default)
0	R/W	TMR_PAUSE	0	Timer control bit 0: Timer is active (default) 1: Timer is pause