



Chipsmall Limited consists of a professional team with an average of over 10 year of expertise in the distribution of electronic components. Based in Hongkong, we have already established firm and mutual-benefit business relationships with customers from,Europe,America and south Asia,supplying obsolete and hard-to-find components to meet their specific needs.

With the principle of "Quality Parts,Customers Priority,Honest Operation,and Considerate Service",our business mainly focus on the distribution of electronic components. Line cards we deal with include Microchip,ALPS,ROHM,Xilinx,Pulse,ON,Everlight and Freescale. Main products comprise IC,Modules,Potentiometer,IC Socket,Relay,Connector.Our parts cover such applications as commercial,industrial, and automotives areas.

We are looking forward to setting up business relationship with you and hope to provide you with the best service and solution. Let us make a better world for our industry!



## Contact us

Tel: +86-755-8981 8866 Fax: +86-755-8427 6832

Email & Skype: info@chipsmall.com Web: www.chipsmall.com

Address: A1208, Overseas Decoration Building, #122 Zhenhua RD., Futian, Shenzhen, China



REVISIONS					
REV	ECO	DESCRIPTION	DATE	BY	APPR
A1		FIRST RELEASED	Apr.05,2016	Drack	Tommy

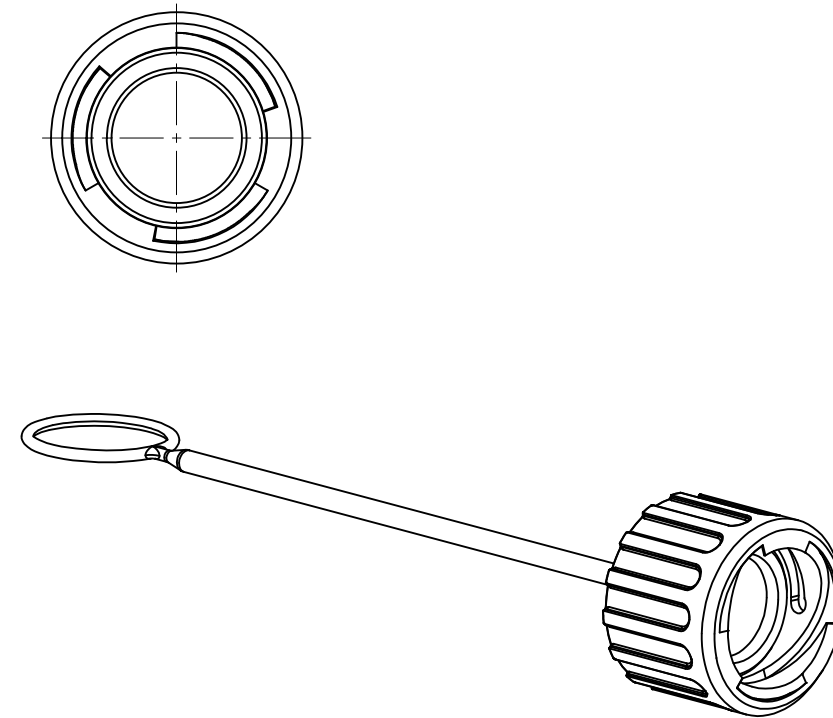
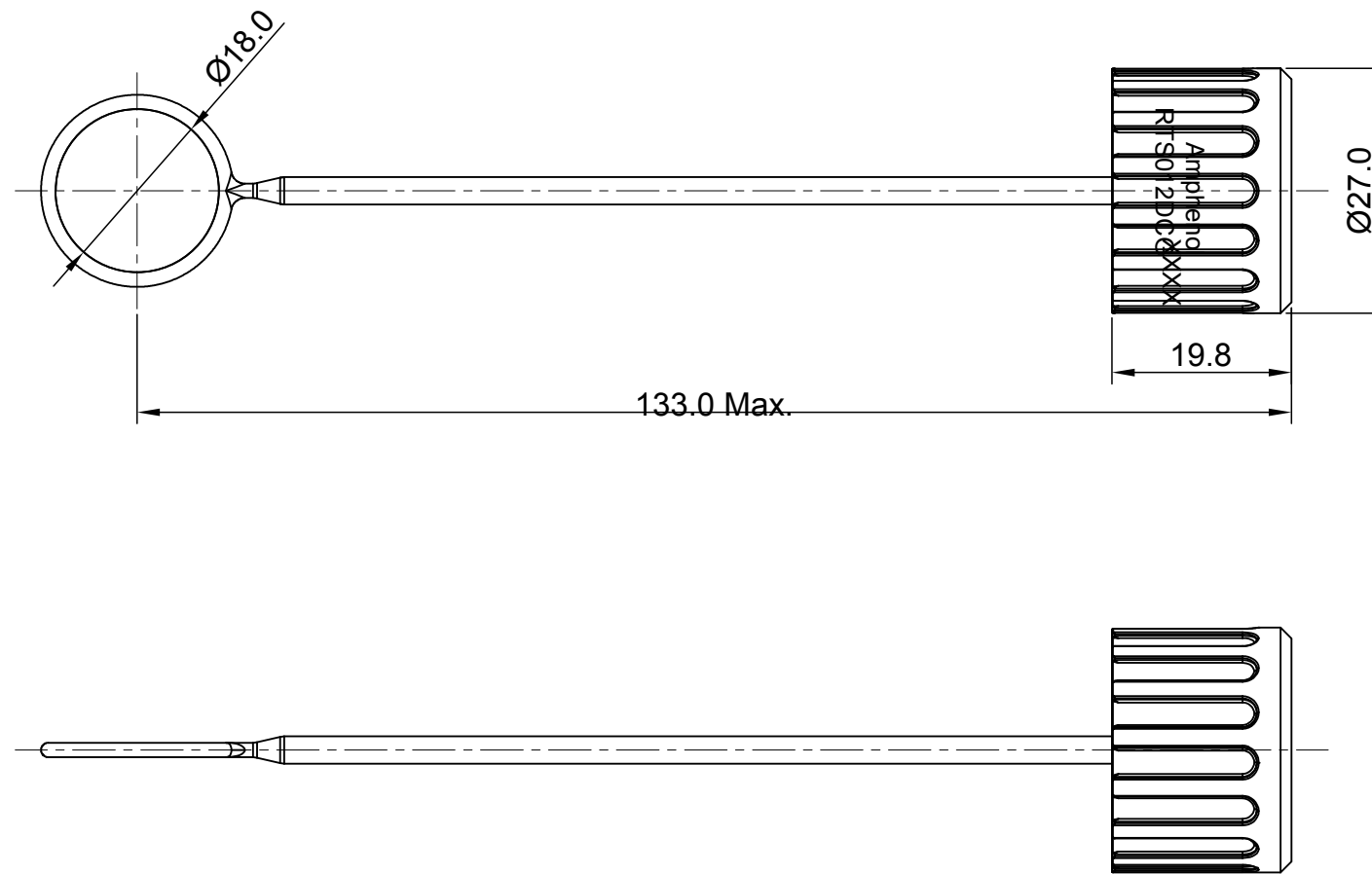

PART NUMBER	
-40°C ~ 105°C	-40°C ~ 125°C
RTS012DCG	RTS012DCG03

NOTES : (UNLESS OTHERWISE SPECIFIED)

- MATERIAL :  
SHELL : THERMOPLASTIC , UL94 V-0.  
SEAL GASKET : NBR OR SR.
- SPECIFICATIONS :  
2.1, OPERATING TEMPERATURE : SEE TABLE.  
2.2, IP-CLASS : IP67.  
2.3, MATING CYCLES DURABILITY : 500 CYCLES MIN.  
2.4, RoHS COMPLIANT.
- ALL DIMENSIONS ARE FOR REFERENCE USE ONLY.

QUANTITY	PART NUMBER	DESCRIPTION	ITEM
<b>MATERIALS LIST</b>			
<p><b>UNLESS OTHERWISE SPECIFIED</b></p> <p>1) All dimensions are in metric (mm).</p> <p>2) PL DEC ±0.15 Angles ±1°</p> <p>3) Note reference = </p>		<p><b>Amphenol</b></p> <p>Sine Systems - www.amphenol-sine.com 44724 Morley Drive Clinton Township, MI 48036</p>	
<p>MATERIAL SPECIFICATIONS:</p> <p>PROCESS SPECIFICATIONS:</p> <p>NEXT ASSY:</p>		<p>CUSTOMER:</p> <p>ECO-MATE, DUST CAP, RECEPTACLE SIZE 12</p> <p>THIS DRAWING IS SUPPLIED FOR INFORMATION ONLY. DESIGN FEATURES, SPECIFICATIONS AND PERFORMANCE DATA SHOWN HEREON ARE THE PROPERTY OF THE AMPHENOL CORPORATION. NO RIGHTS OF REPRODUCTION ARE IMPLIED. ALL DIMENSIONS ARE SUBJECT TO NORMAL MANUFACTURING VARIATIONS.</p>	
<p>SIGNATURES</p> <p>DATE</p> <p>CHECKED:</p> <p>ENGINEER:</p> <p>APPROVAL:</p>		<p>SCALE: NONE</p> <p>SIZE: B C-</p> <p>DWG NO: RTS012DCGxx</p> <p>REVISION: A1</p>	
		<p>SHEET 1 OF 1</p>	

TITLE: ECO-MATE DUST CAP RECEPTACLE SIZE 12  
 DWG NO: RTS012DCGxx  
 REV: A1  
 SH: 1  
 OF: 1