



Chipsmall Limited consists of a professional team with an average of over 10 year of expertise in the distribution of electronic components. Based in Hongkong, we have already established firm and mutual-benefit business relationships with customers from,Europe,America and south Asia,supplying obsolete and hard-to-find components to meet their specific needs.

With the principle of “Quality Parts,Customers Priority,Honest Operation,and Considerate Service”,our business mainly focus on the distribution of electronic components. Line cards we deal with include Microchip,ALPS,ROHM,Xilinx,Pulse,ON,Everlight and Freescale. Main products comprise IC,Modules,Potentiometer,IC Socket,Relay,Connector.Our parts cover such applications as commercial,industrial, and automotives areas.

We are looking forward to setting up business relationship with you and hope to provide you with the best service and solution. Let us make a better world for our industry!



Contact us

Tel: +86-755-8981 8866 Fax: +86-755-8427 6832

Email & Skype: info@chipsmall.com Web: www.chipsmall.com

Address: A1208, Overseas Decoration Building, #122 Zhenhua RD., Futian, Shenzhen, China



REVISIONS					
REV	ECO	DESCRIPTION	DATE	BY	APPR
A1	--	RELEASED DRAWING	Dec-26-2016	Ben	Tommy
A2	--	UPDATE NOTES	Jul-05-2017	Nick	Tommy
A3	--	UPDATE DRAWING	Mar-20-2018	White	Tommy
A4	--	UPDATE DRAWING	Apr-10-2018	White	Tommy

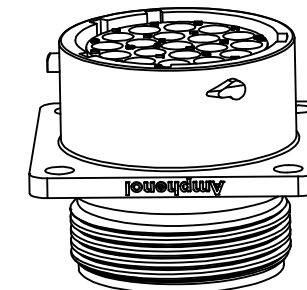
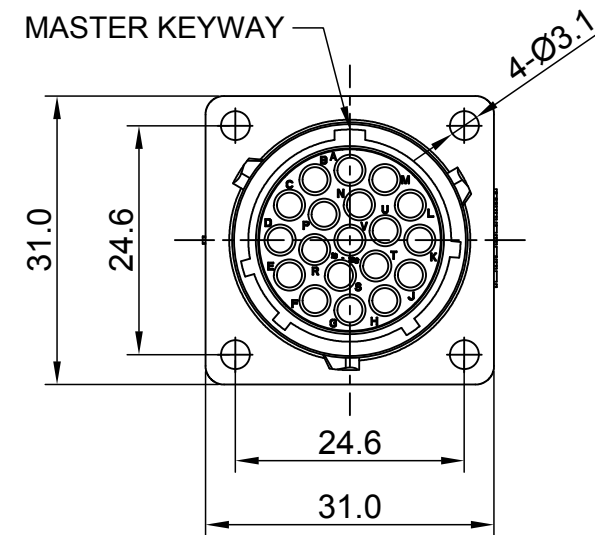
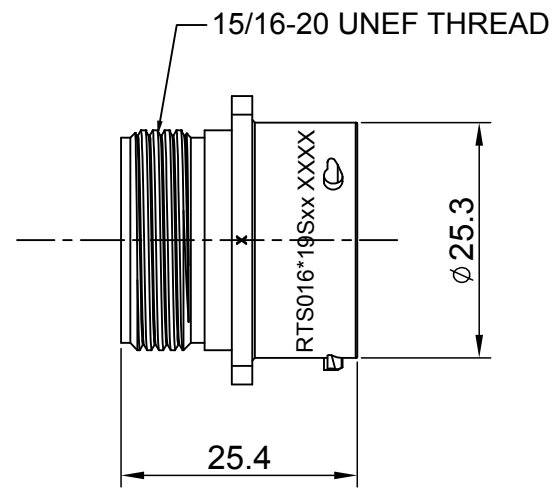

NOTES : (UNLESS OTHERWISE SPECIFIED)

- MATERIAL :
SHELL : THERMOPLASTIC , UL94 V-0.
INSERT : THERMOPLASTIC , UL94 V-0.
SEAL GASKET : NBR/SILICONE RUBBER.
- SPECIFICATIONS :
2.1 RATED CURRENT : 13A MAX.
2.2 RATED VOLTAGE : 500V(AC/DC).
2.3 OPERATING TEMPERATURE : SEE TABLE.
2.4 DIELECTRIC WITHSTANDING VOLTAGE : LESS THAN 2 MILLIAMPS CURRENT LEAKAGE@2000 VOLTS AC.
2.5 INSULATION RESISTANCE : 5000 MEGOHMS MIN.
2.6 IP--CLASS : IP67 AND IP69K IN THE MATED CONDITION, PANEL EXTERNAL.
2.7 MATING CYCLES DURABILITY : 500 CYCLES MIN.
2.8 RoHS COMPLIANT.
- SUITABLE CONTACTS : 16# CONTACT.
- ALL DIMENSIONS ARE FOR REFERENCE USE ONLY.

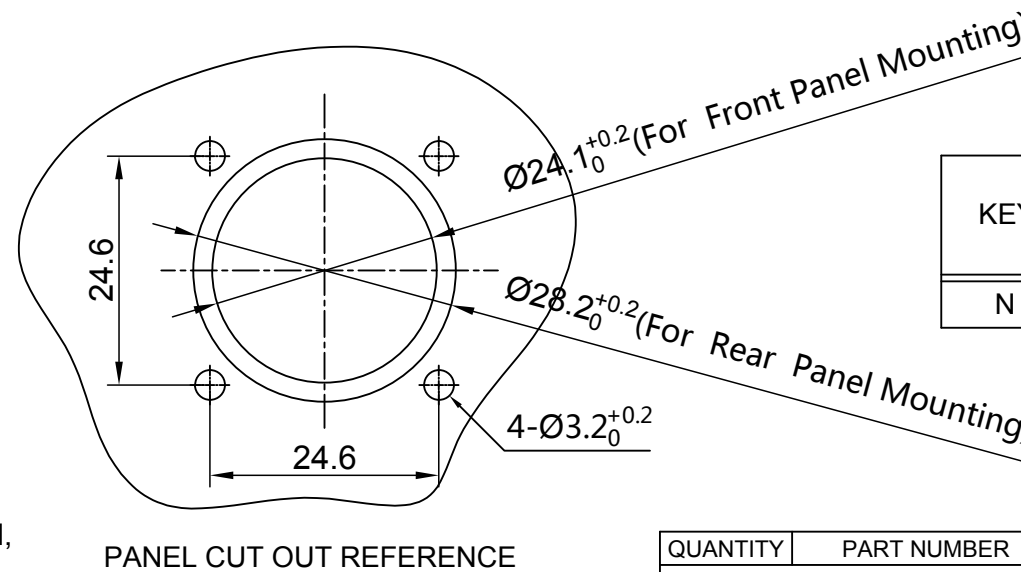

KEY	PART NUMBER	
		-40°C ~ 105°C
N	RTS016N19S	RTS016N19S03

QUANTITY	PART NUMBER	DESCRIPTION	ITEM															
MATERIALS LIST																		
UNLESS OTHERWISE SPECIFIED 1) All dimensions are in metric(mm). 2) Tolerances are as follows: 1 PL DEC ±0.30 Fractions ±1/64 2 PL DEC ±0.15 Angles ±1° 3 PL DEC ±0.08		<table border="1"> <thead> <tr> <th colspan="2">SIGNATURES</th> <th>DATE</th> </tr> </thead> <tbody> <tr> <td>DRAWN: White</td> <td></td> <td>Apr-10-2018</td> </tr> <tr> <td>CHECKED: Tod</td> <td></td> <td>Apr-10-2018</td> </tr> <tr> <td>ENGINEER:</td> <td></td> <td></td> </tr> <tr> <td>APPROVAL: Tommy</td> <td></td> <td>Apr-10-2018</td> </tr> </tbody> </table>		SIGNATURES		DATE	DRAWN: White		Apr-10-2018	CHECKED: Tod		Apr-10-2018	ENGINEER:			APPROVAL: Tommy		Apr-10-2018
SIGNATURES		DATE																
DRAWN: White		Apr-10-2018																
CHECKED: Tod		Apr-10-2018																
ENGINEER:																		
APPROVAL: Tommy		Apr-10-2018																
MATERIAL SPECIFICATIONS:		<p style="text-align: center;">Amphenol</p> <p style="text-align: center;">Sine Systems - www.amphenol-sine.com 44724 Morley Drive Clinton Township, MI 48036</p>																
PROCESS SPECIFICATIONS:		<p style="text-align: center;">ECO-MATE, RECEPTACLE, FLANGE, SIZE 16, 19 POS, SOCKET</p>																
NEXT ASSY:		<table border="1"> <thead> <tr> <th>SIZE</th> <th>TYPE</th> <th>DWG NO:</th> <th>REVISION</th> </tr> </thead> <tbody> <tr> <td>B</td> <td>C-</td> <td>RTS016*19Sxx</td> <td>A4</td> </tr> </tbody> </table>		SIZE	TYPE	DWG NO:	REVISION	B	C-	RTS016*19Sxx	A4							
SIZE	TYPE	DWG NO:	REVISION															
B	C-	RTS016*19Sxx	A4															
SCALE: NONE		SHEET 1 OF 1																

TITLE: ECO-MATE, RECEPTACLE, FLANGE SIZE 16, 19 POS, SOCKET

DWG NO: RTS016*19Sxx

REV: A4

SH: 1

OF: 1