



Chipsmall Limited consists of a professional team with an average of over 10 year of expertise in the distribution of electronic components. Based in Hongkong, we have already established firm and mutual-benefit business relationships with customers from,Europe,America and south Asia,supplying obsolete and hard-to-find components to meet their specific needs.

With the principle of “Quality Parts,Customers Priority,Honest Operation,and Considerate Service”,our business mainly focus on the distribution of electronic components. Line cards we deal with include Microchip,ALPS,ROHM,Xilinx,Pulse,ON,Everlight and Freescale. Main products comprise IC,Modules,Potentiometer,IC Socket,Relay,Connector.Our parts cover such applications as commercial,industrial, and automotives areas.

We are looking forward to setting up business relationship with you and hope to provide you with the best service and solution. Let us make a better world for our industry!



Contact us

Tel: +86-755-8981 8866 Fax: +86-755-8427 6832

Email & Skype: info@chipsmall.com Web: www.chipsmall.com

Address: A1208, Overseas Decoration Building, #122 Zhenhua RD., Futian, Shenzhen, China





Is Now Part of



ON Semiconductor®

To learn more about ON Semiconductor, please visit our website at

www.onsemi.com

ON Semiconductor and the ON Semiconductor logo are trademarks of Semiconductor Components Industries, LLC dba ON Semiconductor or its subsidiaries in the United States and/or other countries. ON Semiconductor owns the rights to a number of patents, trademarks, copyrights, trade secrets, and other intellectual property. A listing of ON Semiconductor's product/patent coverage may be accessed at www.onsemi.com/site/pdf/Patent-Marking.pdf. ON Semiconductor reserves the right to make changes without further notice to any products herein. ON Semiconductor makes no warranty, representation or guarantee regarding the suitability of its products for any particular purpose, nor does ON Semiconductor assume any liability arising out of the application or use of any product or circuit, and specifically disclaims any and all liability, including without limitation special, consequential or incidental damages. Buyer is responsible for its products and applications using ON Semiconductor products, including compliance with all laws, regulations and safety requirements or standards, regardless of any support or applications information provided by ON Semiconductor. "Typical" parameters which may be provided in ON Semiconductor data sheets and/or specifications can and do vary in different applications and actual performance may vary over time. All operating parameters, including "Typicals" must be validated for each customer application by customer's technical experts. ON Semiconductor does not convey any license under its patent rights nor the rights of others. ON Semiconductor products are not designed, intended, or authorized for use as a critical component in life support systems or any FDA Class 3 medical devices or medical devices with a same or similar classification in a foreign jurisdiction or any devices intended for implantation in the human body. Should Buyer purchase or use ON Semiconductor products for any such unintended or unauthorized application, Buyer shall indemnify and hold ON Semiconductor and its officers, employees, subsidiaries, affiliates, and distributors harmless against all claims, costs, damages, and expenses, and reasonable attorney fees arising out of, directly or indirectly, any claim of personal injury or death associated with such unintended or unauthorized use, even if such claim alleges that ON Semiconductor was negligent regarding the design or manufacture of the part. ON Semiconductor is an Equal Opportunity/Affirmative Action Employer. This literature is subject to all applicable copyright laws and is not for resale in any manner.



RV4141A Low-Power, Ground-Fault Interrupter

Features

- Powered from the AC Line
- Built-In Rectifier
- Direct Interface to SCR
- 500µA Quiescent Current
- Precision Sense Amplifier
- Adjustable Time Delay
- Minimum External Components
- Meets UL 943 Requirements
- Compatible with 110V or 220V Systems
- Available in an 8-Pin SOIC Package

Description

The RV4141A is a low-power controller for AC-receptacle, ground-fault circuit interrupters. These devices detect hazardous current paths to ground and ground to neutral faults. The circuit interrupter then disconnects the load from the line before a harmful or lethal shock occurs.

Internally, the RV4141A contains a diode rectifier, shunt regulator, precision sense amplifier, current reference, time-delay circuit, and SCR driver.

Two sense transformers, SCR, solenoid, three resistors, and four capacitors complete the design of the basic circuit interrupter. The simple layout and minimum component count ensure ease of application and long-term reliability. Features not found in other GFCI controllers include a low offset voltage sense amplifier, eliminating the need for a coupling capacitor between the sense transformer and sense amplifier, and an internal rectifier to eliminate high-voltage rectifying diodes.

The RV4141A is powered only during the positive half period of the line voltage, but can sense current faults independent of its phase relative to the line voltage. The gate of the SCR is driven only during the positive half cycle of the line voltage.

Ordering Information

Part Number	Operating Temperature Range	Package	Packing Method
RV4141AN	-35 to +80°C	8-Lead, Plastic Dual-Inline Package (DIP)	Rails
RV4141AMT	-35 to +80°C	8-Lead, Plastic Small-Outline Integrated Circuit (SOIC)	Tape and Reel

Block Diagram

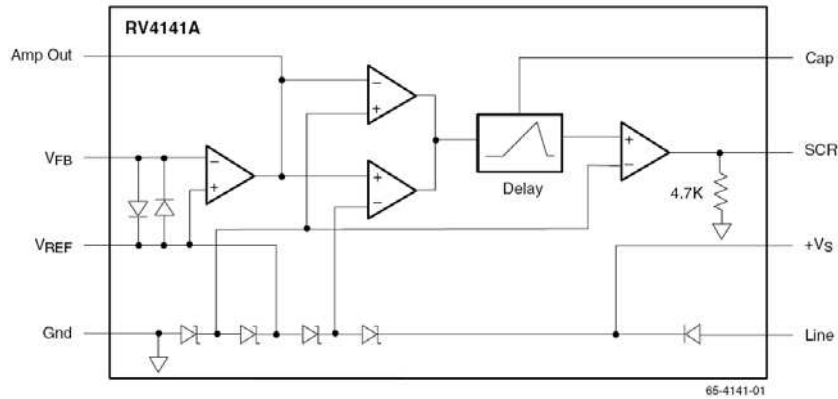

Figure 1. Block Diagram

Pin Configuration

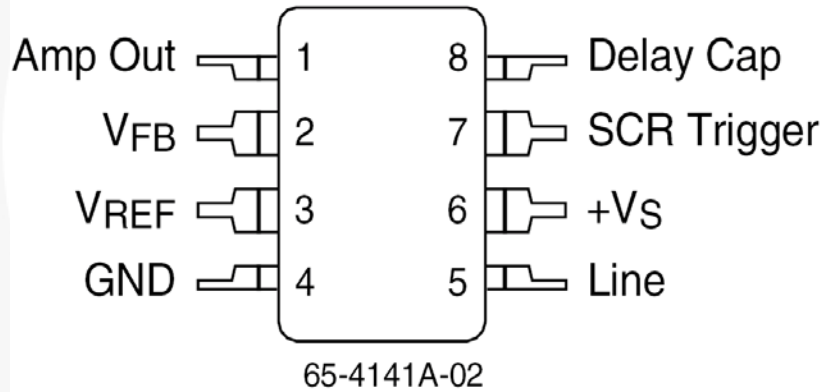

Figure 2. Pin Assignment

Pin Definitions

Pin #	Name	Description
1	Amp Out	Sense Amplifier Output – an external resistor to V _{FB} sets the I _{FAULT} threshold
2	V _{FB}	Sense amplifier negative input
3	V _{REF}	Sense amplifier positive input – biased internally at +V _S /2
4	GND	Substrate ground for all circuitry
5	Line	Anode of internal diode connected to supply voltage
6	+V _S	Supply input for RV4141A circuitry
7	SCR Trigger	Output for triggering external SCR when a fault is detected
8	Delay Cap	An external capacitor to ground sets the delay time for a ground fault to be present before triggering the SCR

Absolute Maximum Ratings

Stresses exceeding the absolute maximum ratings may damage the device. The device may not function or be operable above the recommended operating conditions and stressing the parts to these levels is not recommended. In addition, extended exposure to stresses above the recommended operating conditions may affect device reliability. The absolute maximum ratings are stress ratings only.

Symbol	Parameter	Min.	Max.	Unit
V_{CC}	Power Supply		10	mA
P_D	Internal Power Dissipation		500	mW
T_{STG}	Storage Temperature Range	-65	+150	°C
T_A	Operating Temperature Range	-35	+80	°C
T_J	Junction Temperature		+125	°C
T_L	Lead Soldering Temperature	10 Seconds, SOIC	+260	°C
		60 Seconds, DIP	+300	

Thermal Characteristics

Symbol	Parameter	Typ.	Max.	Unit
Θ_{JA}	Thermal Resistance	SOIC	240	°C/W
		DIP	160	

Electrical Characteristics

$I_{LINE} = 1.5\text{mA}$ and $T_A = +25^\circ\text{C}$, $R_{SET} = 650\text{k}\Omega$.

Symbol	Parameter	Conditions	Min.	Typ.	Max.	Units
Shunt Regulator (Pins 5 to 4)						
V_{REG}	Regulated Voltage	$I_{2-3} = 11\mu\text{A}$	25	27	29	V
		$I_{LINE} = 750\mu\text{A}$, $I_{2-3} = 9\mu\text{A}$	25	27	29	
I_Q	Quiescent Current	$V_{5-4} = 24\text{V}$		500		μA
Sense Amplifier (Pins 2 to 3)						
V_{OFF}	Offset Voltage		-200	0	200	μV
GBW	Gain Bandwidth	Design Value		3		MHz
t_{SK}	Slew Rate	Design Value		1		$\text{V}/\mu\text{S}$
I_{BIAS}	Input Bias Current	Design Value		30	100	nA
SCR Trigger (Pins 7 to 4)						
R_{OUT}	Output Resistance	$V_{7-4} = \text{Open}$, $I_{2-3} = \mu\text{A}$	3.8	4.7	5.6	$\text{k}\Omega$
V_{OUT}	Output Voltage	$I_{2-3} = 9\mu\text{A}$	0	0.1	10.0	mV
		$I_{2-3} = 11\mu\text{A}$	3.0	3.8	4.5	V
I_{OUT}	Output Current	$V_{7-4} = 0\text{V}$, $I_{2-3} = 11\mu\text{A}$	400	600		μA
Reference Voltage (Pins 3 to 4)						
V_{REF}	Reference Voltage	$I_{LINE} = 750\mu\text{A}$	12	13	14	V
Delay Timer (Pins 8 to 4)						
	Discharge / Charge Ratio	$I_{2-3} = 0/11\mu\text{A}$	1.8	2.5	3.0	$\mu\text{A}/\mu\text{A}$
t_{DLY}	Delay Time ⁽¹⁾	$C_{8-4} = 12\text{nF}$		2		ms
I_{DLY}	Delay Current	$I_{2-3} = 11\mu\text{A}$	30	40	50	μA

Notes:

1. Delay time is defined as starting when the instantaneous sense current (I_{2-3}) exceeds $6.5\text{V}/R_{SET}$ and ending when the SCR trigger voltage V_{7-6} goes HIGH.

Circuit Operation

(Refer to Figure 1 and Figure 3.)

The precision op amp connected to pins 1 through 3 senses the fault current flowing in the secondary of the sense transformer, converting it to a voltage at pin 1. The ratio of secondary current to output voltage is directly proportional to feedback resistor, R_{SET} .

R_{SET} converts the sense transformer secondary current to a voltage at pin 1. Due to the virtual ground created at the sense amplifier input by its negative feedback loop, the sense transformer's burden is equal to the value of R_{IN} . From the transformer's point of view, the ideal value for R_{IN} is 0Ω . This causes it to operate as a true current transformer with minimal error. However, making R_{IN} equal to zero creates a large offset voltage at pin 1 due to the sense amplifier's very high DC gain. R_{IN} should be selected as high as possible, consistent with preserving the transformer's operation as a true current mode transformer. A typical value for R_{IN} is between 200 and 1000Ω .

As seen in Equation (1), maximizing R_{IN} minimizes the DC offset error at the sense amplifier output. The DC offset voltage at pin 1 contributes directly to the trip current error. The offset voltage at pin 1 is:

$$V_{OS} \times R_{SET} / (R_{IN} + R_{SEC}) \quad (1)$$

where:

V_{OS} = Input offset voltage of sense amplifier;

R_{SET} = Feedback resistor;

R_{IN} = Input resistor;

R_{SEC} = Transformer secondary winding resistance.

The sense amplifier has a specified maximum offset voltage of $200\mu\text{V}$ to minimize trip current errors. Two comparators connected to the sense amplifier output are configured as a window detector, whose references are -6.5V and $+6.5\text{V}$, referred to pin 3. When the sense transformer secondary RMS current exceeds $4.6/R_{SET}$, the output of the window detector starts the delay circuit. If the secondary current exceeds the predetermined trip current for longer than the delay time, a current pulse appears at pin 7, triggering the SCR.

The SCR anode is directly connected to a solenoid or relay coil. The SCR can be tripped only when its anode is more positive than its cathode.

Supply Current Requirements

The RV4141A is powered directly from the line through a series-limiting resistor called R_{LINE} ; its value is between $24\text{k}\Omega$ and $91\text{k}\Omega$.

The controller IC has a built-in diode rectifier, eliminating the need for external power diodes. The recommended value for R_{LINE} is $24\text{k}\Omega$ to $47\text{k}\Omega$ for 110V systems and $47\text{k}\Omega$ to $91\text{k}\Omega$ for 220V systems. When R_{LINE} is $47\text{k}\Omega$, the shunt regulator current is limited to 3.6mA . The recommended maximum peak line current through R_{LINE} is 10mA .

GFCI Application

(Refer to Figure 3)

The GFCI detects a ground fault by sensing a difference in current in the line and neutral wires. The difference in current is assumed to be a fault current creating a potentially hazardous path from line to ground. Since the line and neutral wires pass through the center of the sense transformer, only the differential primary current is transferred to the secondary. Assuming the turns ratio is 1:1000, the secondary current is 1/1000th the fault current. The RV4141A's sense amplifier converts the secondary current to a voltage compared with either of the two window detector reference voltages. If the fault current exceeds the design value for the duration of the programmed time delay, the RV4141A sends a current pulse to the gate of the SCR.

Detecting ground-to-neutral faults is more difficult. R_B represents a normal ground fault resistance. R_N is the wire resistance of the electrical circuit between load/neutral and earth ground. R_G represents the ground-to-neutral fault condition. According to UL 943, the GFCI must trip when $R_N = 0.4\Omega$, $R_G = 1.6\Omega$, and the normal ground fault is 6mA .

Assuming the ground fault to be 5mA , 1mA , and 4mA goes through R_G and R_N , respectively, causing an effective 1mA fault current. This current is detected by the sense transformer and amplified by the sense amplifier. The ground / neutral and sense transformers are mutually coupled by R_G , R_N , and the neutral wire ground loop, producing a positive feedback loop around the sense amplifier. The newly created feedback loop causes the sense amplifier to oscillate at a frequency determined by ground/neutral transformer secondary inductance and C4, which occurs at 8KHz .

C2 is used to program the time required for the fault to be present before the SCR is triggered. Refer to Equation (2) for calculating the value of C2. Its typical value is 12nF for a 2ms delay. R_{SET} is used to set the fault current at which the GFCI trips. When used with a 1:1000 sense transformer, its typical value is $1\text{M}\Omega$ for a GFCI designed to trip at 5mA .

R_{IN} should be the highest value possible that ensures a predictable secondary current from the sense transformer. If R_{IN} is set too high, normal production variations in the transformer permeability causes unit-to-unit variations in the secondary current. If it is too low, a large offset voltage error at pin 1 is present. This error voltage in turn creates a trip current error proportional to the input offset voltage of the sense amplifier. As an example, if R_{IN} is 500Ω , R_{SET} is $1\text{M}\Omega$, R_{SEC} is 45Ω , and the V_{OS} of the sense amplifier is its maximum of $200\mu\text{V}$; the trip current error is $\pm 5.6\%$.

The SCR anode is directly connected to a solenoid or relay coil. It can be tripped only when its anode is more positive than its cathode. It must have a high dV/dt rating to ensure that line noise (generated by electrically noisy appliances) does not falsely trigger it. Also the SCR must have a gate drive requirement less than 200µA. C3 is a noise filter that prevents high-frequency line pulses from triggering the SCR. The relay solenoid should have a response time of 3ms or less to meet the UL 943 timing requirement.

Sense Transformers and Cores

The sense and ground/neutral transformer cores are usually fabricated using high-permeability laminated steel rings. Their single-turn primary is created by passing the line and neutral wires through the center of its core. The secondary is usually from 200 to 1500 turns. Transformers may be obtained from Magnetic Metals, Inc. (www.magmet.com).

Calculating the Values of R_{SET} and C2

Determine the nominal ground-fault trip-current requirement. This is typically 5mA in North America (117V_{AC}) and 22mA in the UK and Europe (220V_{AC}). Determine the minimum delay time required to prevent nuisance tripping, typically 1 to 2ms. The value of C2 required to provide the desired delay time is:

$$C2 = 6 \times t \quad (2)$$

where:

C2 is in nF and t is the desired delay time in ms.

The value of R_{SET} to meet the nominal ground fault trip current specification is:

$$R_{SET} = \frac{4.6 \times N}{I_{FAULT} \times \cos 180(t/P)} \quad (3)$$

where:

R_{SET} is in kΩ;

t is the time delay in ms;

P is the period of the line frequency in ms;

I_{FAULT} is the desired ground fault trip current in mA RMS;

N is the number of sense transformer secondary turns.

Note:

- This formula assumes an ideal sense transformer is used. The calculated value of R_{SET} may have to be changed up to 30% when using a non-ideal transformer.

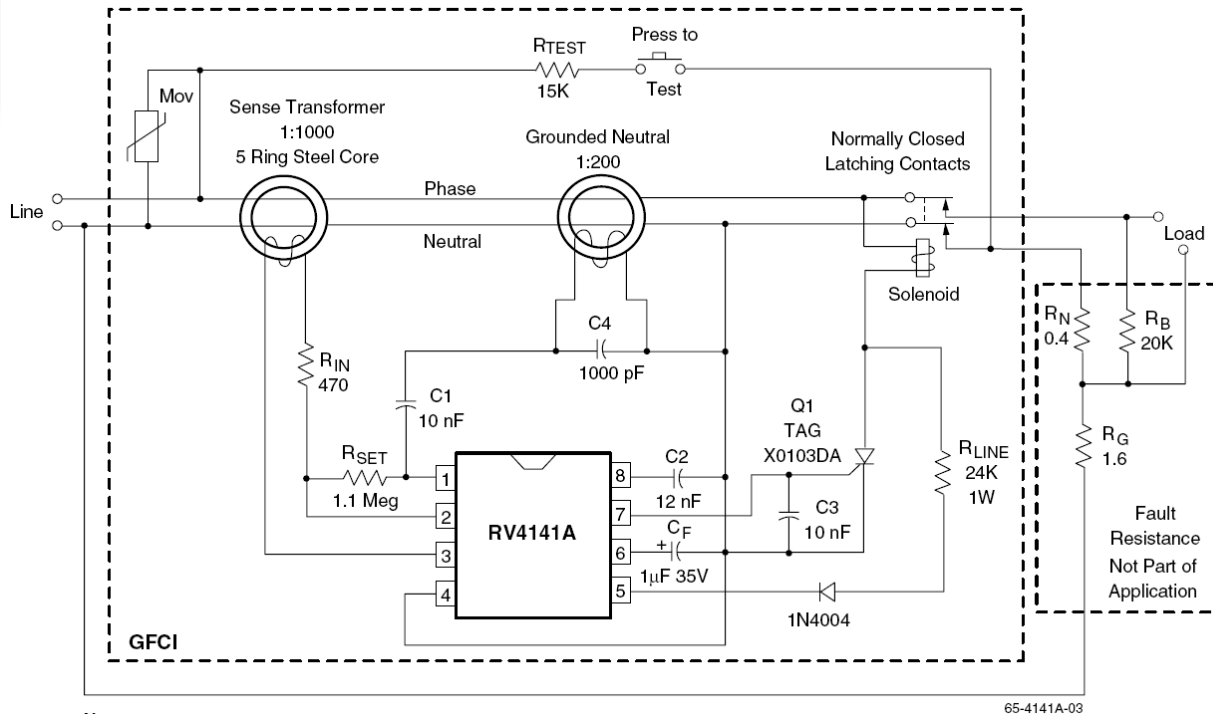

Figure 3. GFI Application Circuit

Physical Dimensions

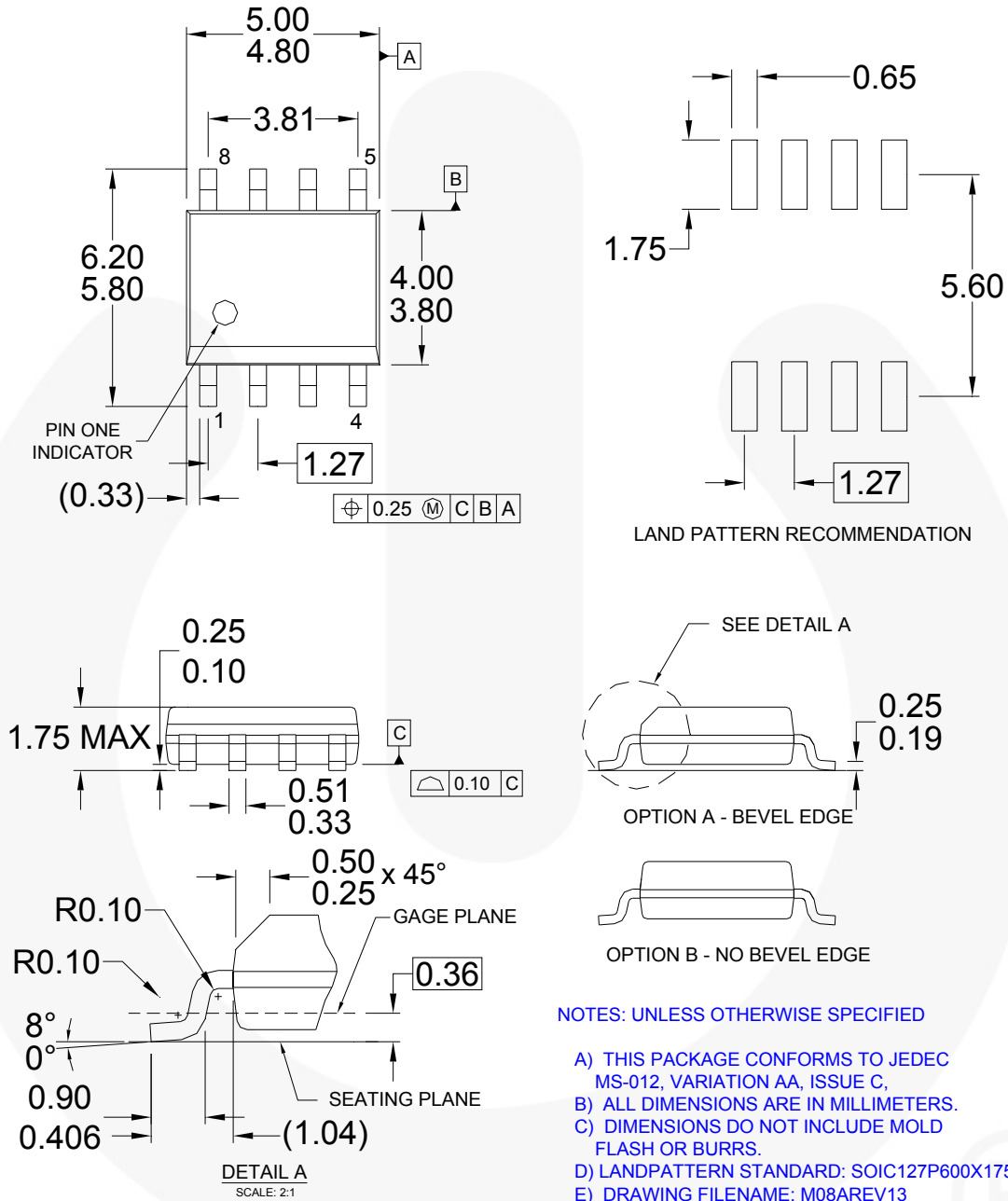

Figure 5. 8-Lead, Plastic Small-Outline Integrated Circuit (SOIC)

Package drawings are provided as a service to customers considering Fairchild components. Drawings may change in any manner without notice. Please note the revision and/or date on the drawing and contact a Fairchild Semiconductor representative to verify or obtain the most recent revision. Package specifications do not expand the terms of Fairchild's worldwide terms and conditions, specifically the warranty therein, which covers Fairchild products.

Always visit Fairchild Semiconductor's online packaging area for the most recent package drawings:
<http://www.fairchildsemi.com/packaging/>.



TRADEMARKS

The following includes registered and unregistered trademarks and service marks, owned by Fairchild Semiconductor and/or its global subsidiaries, and is not intended to be an exhaustive list of all such trademarks.

2Cool™
AccuPower™
Auto-SPM™
AX-CAP™*
BitSiC™
Build it Now™
CorePLUS™
CorePOWER™
CROSSVOLT™
CTL™
Current Transfer Logic™
DEUXPEED®
Dual Cool™
EcoSPARK®
EfficientMax™
ESBC™
F®
Fairchild®
Fairchild Semiconductor®
FACT Quiet Series™
FACT®
FAST®
FastvCore™
FETBench™
FlashWriter®*

FPS™
F-PFS™
FRFET®
Global Power Resource™
GreenBridge™
Green FPS™
Green FPS™ e-Series™
Gmax™
GTO™
IntelliMAX™
ISOPLANAR™
Making Small Speakers Sound Louder and Better™
MegaBuck™
MICROCOUPLER™
MicroFET™
MicroPak™
MicroPak2™
MillerDrive™
MotionMax™
Motion-SPM™
mWSaver™
OptoHiT™
OPTOLOGIC®
OPTOPLANAR®

®
PowerTrench®
PowerXS™
Programmable Active Droop™
QFET®
QS™
Quiet Series™
RapidConfigure™
™
Saving our world, 1mW/W/kW at a time™
SignalWise™
SmartMax™
SMART START™
Solutions for Your Success™
SPM®
STEALTH™
SuperFET®
SuperSOT™-3
SuperSOT™-6
SuperSOT™-8
SupreMOS®
SyncFET™
Sync-Lock™
 SYSTEM GENERAL®*

The Power Franchise®
the **p**ower franchise
TinyBoost™
TinyBuck™
TinyCalc™
TinyLogic®
TINYOPTO™
TinyPower™
TinyPWM™
TinyWire™
TranSiC™
TriFault Detect™
TRUECURRENT®*
µSerDes™
 SerDes®
UHC®
Ultra FRFET™
UniFET™
VCX™
VisualMax™
VoltagePlus™
XS™

* Trademarks of System General Corporation, used under license by Fairchild Semiconductor.

DISCLAIMER

FAIRCHILD SEMICONDUCTOR RESERVES THE RIGHT TO MAKE CHANGES WITHOUT FURTHER NOTICE TO ANY PRODUCTS HEREIN TO IMPROVE RELIABILITY, FUNCTION, OR DESIGN. FAIRCHILD DOES NOT ASSUME ANY LIABILITY ARISING OUT OF THE APPLICATION OR USE OF ANY PRODUCT OR CIRCUIT DESCRIBED HEREIN; NEITHER DOES IT CONVEY ANY LICENSE UNDER ITS PATENT RIGHTS, NOR THE RIGHTS OF OTHERS. THESE SPECIFICATIONS DO NOT EXPAND THE TERMS OF FAIRCHILD'S WORLDWIDE TERMS AND CONDITIONS, SPECIFICALLY THE WARRANTY THEREIN, WHICH COVERS THESE PRODUCTS.

LIFE SUPPORT POLICY

FAIRCHILD'S PRODUCTS ARE NOT AUTHORIZED FOR USE AS CRITICAL COMPONENTS IN LIFE SUPPORT DEVICES OR SYSTEMS WITHOUT THE EXPRESS WRITTEN APPROVAL OF FAIRCHILD SEMICONDUCTOR CORPORATION.

As used herein:

1. Life support devices or systems are devices or systems which, (a) are intended for surgical implant into the body or (b) support or sustain life, and (c) whose failure to perform when properly used in accordance with instructions for use provided in the labeling, can be reasonably expected to result in a significant injury of the user.
2. A critical component in any component of a life support, device, or system whose failure to perform can be reasonably expected to cause the failure of the life support device or system, or to affect its safety or effectiveness.

ANTI-COUNTERFEITING POLICY

Fairchild Semiconductor Corporation's Anti-Counterfeiting Policy. Fairchild's Anti-Counterfeiting Policy is also stated on our external website, www.fairchildsemi.com, under Sales Support.

Counterfeiting of semiconductor parts is a growing problem in the industry. All manufacturers of semiconductor products are experiencing counterfeiting of their parts. Customers who inadvertently purchase counterfeit parts experience many problems such as loss of brand reputation, substandard performance, failed applications, and increased cost of production and manufacturing delays. Fairchild is taking strong measures to protect ourselves and our customers from the proliferation of counterfeit parts. Fairchild strongly encourages customers to purchase Fairchild parts either directly from Fairchild or from Authorized Fairchild Distributors who are listed by country on our web page cited above. Products customers buy either from Fairchild directly or from Authorized Fairchild Distributors are genuine parts, have full traceability, meet Fairchild's quality standards for handling and storage and provide access to Fairchild's full range of up-to-date technical and product information. Fairchild and our Authorized Distributors will stand behind all warranties and will appropriately address any warranty issues that may arise. Fairchild will not provide any warranty coverage or other assistance for parts bought from Unauthorized Sources. Fairchild is committed to combat this global problem and encourage our customers to do their part in stopping this practice by buying direct or from authorized distributors.

PRODUCT STATUS DEFINITIONS

Definition of Terms

Datasheet Identification	Product Status	Definition
Advance Information	Formative / In Design	Datasheet contains the design specifications for product development. Specifications may change in any manner without notice.
Preliminary	First Production	Datasheet contains preliminary data; supplementary data will be published at a later date. Fairchild Semiconductor reserves the right to make changes at any time without notice to improve design.
No Identification Needed	Full Production	Datasheet contains final specifications. Fairchild Semiconductor reserves the right to make changes at any time without notice to improve the design.
Obsolete	Not In Production	Datasheet contains specifications on a product that is discontinued by Fairchild Semiconductor. The datasheet is for reference information only.

Rev. I60

ON Semiconductor and  are trademarks of Semiconductor Components Industries, LLC dba ON Semiconductor or its subsidiaries in the United States and/or other countries. ON Semiconductor owns the rights to a number of patents, trademarks, copyrights, trade secrets, and other intellectual property. A listing of ON Semiconductor's product/patent coverage may be accessed at www.onsemi.com/site/pdf/Patent-Marking.pdf. ON Semiconductor reserves the right to make changes without further notice to any products herein. ON Semiconductor makes no warranty, representation or guarantee regarding the suitability of its products for any particular purpose, nor does ON Semiconductor assume any liability arising out of the application or use of any product or circuit, and specifically disclaims any and all liability, including without limitation special, consequential or incidental damages. Buyer is responsible for its products and applications using ON Semiconductor products, including compliance with all laws, regulations and safety requirements or standards, regardless of any support or applications information provided by ON Semiconductor. "Typical" parameters which may be provided in ON Semiconductor data sheets and/or specifications can and do vary in different applications and actual performance may vary over time. All operating parameters, including "Typicals" must be validated for each customer application by customer's technical experts. ON Semiconductor does not convey any license under its patent rights nor the rights of others. ON Semiconductor products are not designed, intended, or authorized for use as a critical component in life support systems or any FDA Class 3 medical devices or medical devices with a same or similar classification in a foreign jurisdiction or any devices intended for implantation in the human body. Should Buyer purchase or use ON Semiconductor products for any such unintended or unauthorized application, Buyer shall indemnify and hold ON Semiconductor and its officers, employees, subsidiaries, affiliates, and distributors harmless against all claims, costs, damages, and expenses, and reasonable attorney fees arising out of, directly or indirectly, any claim of personal injury or death associated with such unintended or unauthorized use, even if such claim alleges that ON Semiconductor was negligent regarding the design or manufacture of the part. ON Semiconductor is an Equal Opportunity/Affirmative Action Employer. This literature is subject to all applicable copyright laws and is not for resale in any manner.

PUBLICATION ORDERING INFORMATION

LITERATURE FULFILLMENT:

Literature Distribution Center for ON Semiconductor
19521 E. 32nd Pkwy, Aurora, Colorado 80011 USA
Phone: 303-675-2175 or 800-344-3860 Toll Free USA/Canada
Fax: 303-675-2176 or 800-344-3867 Toll Free USA/Canada
Email: orderlit@onsemi.com

N. American Technical Support: 800-282-9855 Toll Free
USA/Canada
Europe, Middle East and Africa Technical Support:
Phone: 421 33 790 2910
Japan Customer Focus Center
Phone: 81-3-5817-1050

ON Semiconductor Website: www.onsemi.com
Order Literature: <http://www.onsemi.com/orderlit>
For additional information, please contact your local
Sales Representative