



Chipsmall Limited consists of a professional team with an average of over 10 year of expertise in the distribution of electronic components. Based in Hongkong, we have already established firm and mutual-benefit business relationships with customers from,Europe,America and south Asia,supplying obsolete and hard-to-find components to meet their specific needs.

With the principle of “Quality Parts,Customers Priority,Honest Operation,and Considerate Service”,our business mainly focus on the distribution of electronic components. Line cards we deal with include Microchip,ALPS,ROHM,Xilinx,Pulse,ON,Everlight and Freescale. Main products comprise IC,Modules,Potentiometer,IC Socket,Relay,Connector.Our parts cover such applications as commercial,industrial, and automotives areas.

We are looking forward to setting up business relationship with you and hope to provide you with the best service and solution. Let us make a better world for our industry!



## Contact us

Tel: +86-755-8981 8866 Fax: +86-755-8427 6832

Email & Skype: info@chipsmall.com Web: www.chipsmall.com

Address: A1208, Overseas Decoration Building, #122 Zhenhua RD., Futian, Shenzhen, China





Product Number (Please contact us)  
RX6110SA B : X1B000232000100

# REAL TIME CLOCK MODULE (SPI & I<sup>2</sup>C-Bus)

Power Switching and Low current consumption

## RX6110SA B

- Built in frequency adjusted 32.768 kHz crystal unit.
- Interface Type : SPI & I<sup>2</sup>C -Bus
- Operating voltage range : 1.6 V to 5.5 V
- The wide voltage for time keeping : 1.1 V to 5.5 V
- Low backup current : 130 nA / 3 V ( Typ. )
- Built-in user RAM : 128 bit ( 8 bit × 16, SRAM)
- Auto power switching functions : When VDD deteriorates than 1.6V, internal source is switched to VBAT.

• The various functions include full calendar, alarm, timer.  
Epson prepared Linux driver for development.  
([http://www5.epsondevice.com/en/information/support/linux\\_rtc/](http://www5.epsondevice.com/en/information/support/linux_rtc/))

The registered trademark Linux® is used pursuant to a sublicense from LMI(Linux Mark Institute)  
The I<sup>2</sup>C-Bus is a trademark of NXP Semiconductors



Actual size



### Block diagram

### Overview

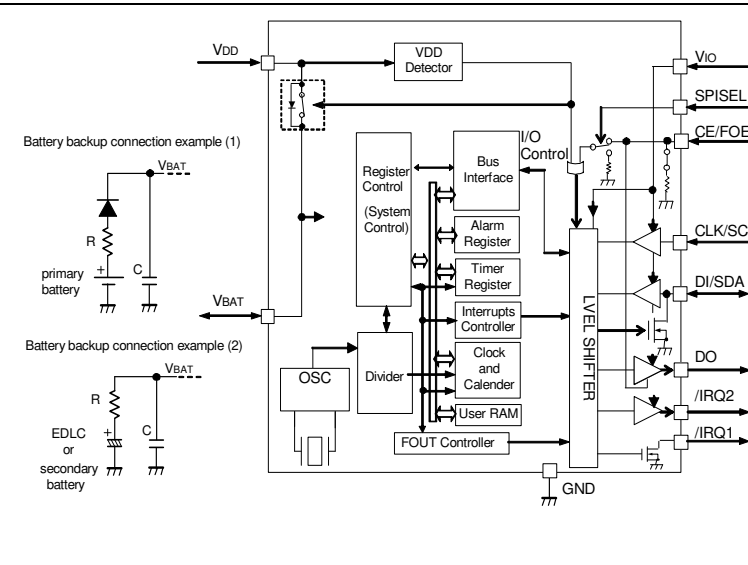

- Interface type.
  - SPI-Bus and I<sup>2</sup>C-Bus interface.
  - By a terminal, a switchover of the interface is possible.
- Built-in auto power switching function
  - To efficiently charge from VDD to backup battery (Secondary battery, Large capacitor) connected to VBAT is possible. Detects VDD voltage drop(VDET-) and automatically switches to the backup battery.
- Frequency output function
  - Output frequency is selectable from 32.768kHz, 1024Hz, 1Hz.
- Timer function
  - Timer function is selectable in 1/4096 second from 65535 hours.
  - Timer source clock are 1 hour, 1min, 64Hz, 4096Hz.
  - It is recorded automatic to TF-bit at the time of event occurrence, and possible to output with /IRQ1 or /IRQ2 pin.
- Alarm function
  - Alarm function can be set to day of week, day, hour, and minute.
  - It is recorded automatic to AF-bit at the alarm occurrence, and possible to output with /IRQ1 pin output.
- User RAM
  - 128 bit (8 bit x 16, SRAM)

### Pin Function

### Terminal connection / External dimensions

(Unit:mm)

Signal Name	Input/Output	Function
SPISEL	Input	The interface select pin. SPI is chosen at a "H" level (V <sub>IO</sub> voltage) / I <sup>2</sup> C is chosen at a "L" level (GND voltage).
CE/FOE	Input	SPI: Should be held high to allow access to the CPU. Incorporates a pull-down resistor. I <sup>2</sup> C: It is an input pin for controlling the DO/FOUT output. When the frequency output from a DO/FOUT pin does not need, CE/FOE pin must be connected to GND.
CLK/SCL	Input	This is a shift clock input pin for serial data transmission.
DI/SDA	Input / Output	SPI: This is the data input pin for serial data transfer. I <sup>2</sup> C: This is the data input/output pin for serial data transfer.
DO/FOUT	Output	SPI: This is the data output pin for serial data transfer. I <sup>2</sup> C: This is the C-MOS output pin with output control provided via the CE/FOE pin. (frequency selection: 32.768 kHz / 1024 Hz / 1Hz / Hi-z)
/IRQ1	Output	This pin outputs interrupt signals ("L" level) for alarm, timer, time update, and FOUT. This is an N-ch open-drain output. This pin can output even a backup mode.
/IRQ2	Output	This pin outputs interrupt signals ("L" level) for timer and FOUT. This is an C-MOS output. This pin becomes Hi-z in less than V <sub>DD</sub> =1.6V.
VDD	-	This is a power-supply pin. It can impress the voltage unlike V <sub>IO</sub> .
V <sub>IO</sub>	-	This pin is a power supply for input and the output and input / output pins. Connected to a positive power supply.
VBAT	-	Connect a secondary battery or capacitor for backup power supply. If a backup power supply is not present, this pin connect to V <sub>DD</sub> .
GND	-	Connected to a ground.

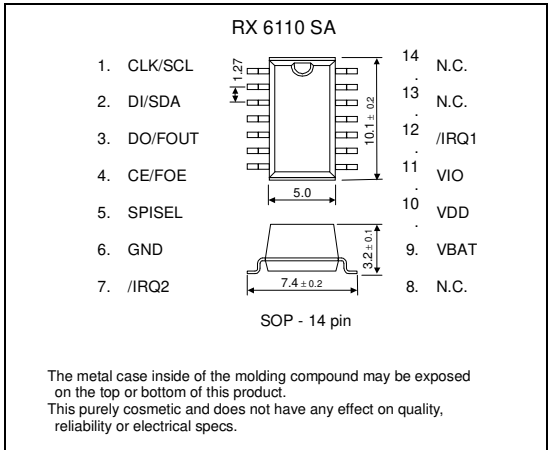

### Specifications (characteristics)

\* Refer to application manual for details.

#### Recommended Operating Conditions

Item	Symbol	Conditions	Min.	Typ.	Max.	Unit
Power voltage	V <sub>DD</sub>	—	1.6	3.0	5.5	V
Clock voltage	V <sub>CLK</sub>	—	1.1	3.0	5.5	V
Operating temperature	T <sub>OPR</sub>	—	-40	+25	+85	°C

#### Frequency characteristics

Item	Symbol	Conditions	Rating	Unit
Frequency tolerance	Δf/f	T <sub>A</sub> = +25 °C V <sub>DD</sub> = 3.0 V	B: 5 ± 23 *1	× 10 <sup>-6</sup>
Oscillation start-up time	t <sub>STA</sub>	T <sub>A</sub> = +25 °C V <sub>DD</sub> = 1.6 V	1 Max.	s

\*1) Equivalent to 1 minute of monthly deviation (excluding offset.) / Standard product

#### Current consumption characteristics

T<sub>A</sub> = -40 °C to +85 °C

Item	Symbol	Conditions	Min.	Typ.	Max.	Unit
Current Consumption	I <sub>BK</sub>	V <sub>BAT</sub> = 3.0 V Input pins are "L", V <sub>DD</sub> = 0 V DO/FOUT=OFF, f <sub>CLK</sub> = 0 Hz, /IRQ1,2 = OFF, TSEL2="1" It include an OFF leak current of SW between the power supply (VBAT-VDD)	-	130	250	nA
	I <sub>32k</sub>	V <sub>DD</sub> = 3.0 V f <sub>CLK</sub> = 0 Hz, /IRQ1,2 = OFF, CE/FOE = V <sub>IO</sub> , DO/FOUT : 32.768 kHz ON, CL = 0 pF	-	1.5	2.1	μA



## PROMOTION OF ENVIRONMENTAL MANAGEMENT SYSTEM CONFORMING TO INTERNATIONAL STANDARDS

At Seiko Epson, all environmental initiatives operate under the Plan-Do-Check-Action (PDCA) cycle designed to achieve continuous improvements. The environmental management system (EMS) operates under the ISO 14001 environmental management standard.

All of our major manufacturing and non-manufacturing sites, in Japan and overseas, completed the acquisition of ISO 14001 certification.

ISO 14000 is an international standard for environmental management that was established by the International Standards Organization in 1996 against the background of growing concern regarding global warming, destruction of the ozone layer, and global deforestation.





## WORKING FOR HIGH QUALITY

In order provide high quality and reliable products and services than meet customer needs,

Seiko Epson made early efforts towards obtaining ISO9000 series certification and has acquired ISO9001 for all business establishments in Japan and abroad. We have also acquired ISO/TS 16949 certification that is requested strongly by major automotive manufacturers as standard.

ISO/TS16949 is the international standard that added the sector-specific supplemental requirements for automotive industry based on ISO9001.

### ► Explanation of the mark that are using it for the catalog

	► Pb free.
	► Complies with EU RoHS directive. *About the products without the Pb-free mark. Contains Pb in products exempted by EU RoHS directive. (Contains Pb in sealing glass, high melting temperature type solder or other.)
	► Designed for automotive applications such as Car Multimedia, Body Electronics, Remote Keyless Entry etc.
	► Designed for automotive applications related to driving safety (Engine Control Unit, Air Bag, ESC etc).

## Notice

- This material is subject to change without notice.
- Any part of this material may not be reproduced or duplicated in any form or any means without the written permission of Seiko Epson.
- The information about applied data, circuitry, software, usage, etc. written in this material is intended for reference only. Seiko Epson does not assume any liability for the occurrence of customer damage or infringing on any patent or copyright of a third party. This material does not authorize the licensing for any patent or intellectual copyrights.
- When exporting the products or technology described in this material, you should comply with the applicable export control laws and regulations and follow the procedures required by such laws and regulations.
- You are requested not to use the products (and any technical information furnished, if any) for the development and/or manufacture of weapon of mass destruction or for other military purposes. You are also requested that you would not make the products available to any third party who may use the products for such prohibited purposes.
- These products are intended for general use in electronic equipment. When using them in specific applications that require extremely high reliability, such as the applications stated below, you must obtain permission from Seiko Epson in advance.  
/ Space equipment (artificial satellites, rockets, etc.) / Transportation vehicles and related (automobiles, aircraft, trains, vessels, etc.) / Medical instruments to sustain life / Submarine transmitters / Power stations and related / Fire work equipment and security equipment / traffic control equipment / and others requiring equivalent reliability.
- All brands or product names mentioned herein are trademarks and/or registered trademarks of their respective.