



Chipsmall Limited consists of a professional team with an average of over 10 year of expertise in the distribution of electronic components. Based in Hongkong, we have already established firm and mutual-benefit business relationships with customers from,Europe,America and south Asia,supplying obsolete and hard-to-find components to meet their specific needs.

With the principle of “Quality Parts,Customers Priority,Honest Operation,and Considerate Service”,our business mainly focus on the distribution of electronic components. Line cards we deal with include Microchip,ALPS,ROHM,Xilinx,Pulse,ON,Everlight and Freescale. Main products comprise IC,Modules,Potentiometer,IC Socket,Relay,Connector.Our parts cover such applications as commercial,industrial, and automotives areas.

We are looking forward to setting up business relationship with you and hope to provide you with the best service and solution. Let us make a better world for our industry!



Contact us

Tel: +86-755-8981 8866 Fax: +86-755-8427 6832

Email & Skype: info@chipsmall.com Web: www.chipsmall.com

Address: A1208, Overseas Decoration Building, #122 Zhenhua RD., Futian, Shenzhen, China





TM Series
GNSS Receiver Module
Data Guide

Wireless made simple[®]

Warning: Some customers may want Linx radio frequency (“RF”) products to control machinery or devices remotely, including machinery or devices that can cause death, bodily injuries, and/or property damage if improperly or inadvertently triggered, particularly in industrial settings or other applications implicating life-safety concerns (“Life and Property Safety Situations”).

NO OEM LINX REMOTE CONTROL OR FUNCTION MODULE SHOULD EVER BE USED IN LIFE AND PROPERTY SAFETY SITUATIONS. No OEM Linx Remote Control or Function Module should be modified for Life and Property Safety Situations. Such modification cannot provide sufficient safety and will void the product’s regulatory certification and warranty.

Customers may use our (non-Function) Modules, Antenna and Connectors as part of other systems in Life Safety Situations, but only with necessary and industry appropriate redundancies and in compliance with applicable safety standards, including without limitation, ANSI and NFPA standards. It is solely the responsibility of any Linx customer who uses one or more of these products to incorporate appropriate redundancies and safety standards for the Life and Property Safety Situation application.

Do not use this or any Linx product to trigger an action directly from the data line or RSSI lines without a protocol or encoder/decoder to validate the data. Without validation, any signal from another unrelated transmitter in the environment received by the module could inadvertently trigger the action.

All RF products are susceptible to RF interference that can prevent communication. RF products without frequency agility or hopping implemented are more subject to interference. This module does not have a frequency hopping protocol built in.

Do not use any Linx product over the limits in this data guide. Excessive voltage or extended operation at the maximum voltage could cause product failure. Exceeding the reflow temperature profile could cause product failure which is not immediately evident.

Do not make any physical or electrical modifications to any Linx product. This will void the warranty and regulatory and UL certifications and may cause product failure which is not immediately evident.

Table of Contents

1	Description
1	Features
1	Applications Include
2	Ordering Information
2	Absolute Maximum Ratings
2	Electrical Specifications
4	Pin Assignments
4	Pin Descriptions
5	A Brief Overview of GNSS
6	Time To First Fix (TTFF)
6	Module Description
7	Backup Battery
7	Power Supply Requirements
7	The 1PPS Output
7	Hybrid Ephemeris Prediction (AGPS)
8	Antenna Considerations
9	Power Control
10	Slow Start Time
11	Interfacing with NMEA Messages
12	NMEA Output Messages
20	Input Messages
40	Typical Applications
41	Microstrip Details
42	Board Layout Guidelines
43	Pad Layout
44	Production Guidelines
44	Hand Assembly
44	Automated Assembly
46	Master Development System

TM Series GNSS Receiver

Data Guide



Description

The TM Series GNSS receiver module is a self-contained high-performance Global Satellite Navigation System receiver. Based on the MediaTek chipset, it can simultaneously acquire and track multiple satellite constellations. These include the United States GPS system, Europe's GALILEO, Russia's GLONASS and Japan's QZSS.

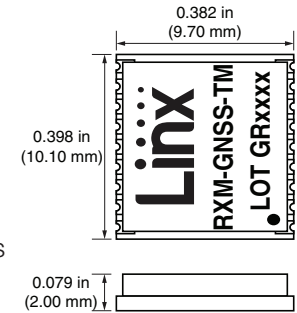

Figure 1: Package Dimensions

The module has an internal Low Noise Amplifier (LNA) that provides exceptional sensitivity, even in dense foliage and urban canyons. Its very low power consumption helps maximize runtimes in battery powered applications. Hybrid ephemeris prediction can be used to achieve cold start times of less than 15 seconds. The module outputs standard NMEA data through a UART interface.

Housed in a tiny reflow-compatible SMD package, the receiver requires no programming or additional RF components (except an antenna) to form a complete GNSS solution. This makes the TM Series easy to integrate, even by engineers without previous RF or GNSS experience.

Features

- MediaTek chipset
- High sensitivity (-164dBm)
- Fast TTFF at low signal levels
- Battery-backed SRAM
- 3-day ephemeris prediction
- No programming necessary
- No external RF components needed (except an antenna)
- No production tuning
- UART serial interface
- Power control features
- Compact SMD package

Applications Include

- Positioning and Navigation
- Location and Tracking
- Security/Loss-Prevention
- Surveying
- Logistics
- Fleet Management

Warning: This product incorporates numerous static-sensitive components. Always wear an ESD wrist strap and observe proper ESD handling procedures when working with this device. Failure to observe this precaution may result in module damage or failure.

Ordering Information

Ordering Information	
Part Number	Description
RXM-GNSS-TM-x	TM Series GNSS Receiver Module
MDEV-GNSS-TM	TM Series GNSS Receiver Master Development System
EVM-GNSS-TM	TM Series Evaluation Module

x = "T" for Tape and Reel, "B" for Bulk
 Reels are 1,000 pieces
 Quantities less than 1,000 pieces are supplied in bulk

Figure 2: Ordering Information

Absolute Maximum Ratings

Absolute Maximum Ratings				
Supply Voltage V_{CC}		+4.3		VDC
Input Battery Backup Voltage		+4.3		VDC
VCC_RF Output Current		50		mA
Operating Temperature	-40	to	+85	°C
Storage Temperature	-40	to	+85	°C

Exceeding any of the limits of this section may lead to permanent damage to the device. Furthermore, extended operation at these maximum ratings may reduce the life of this device.

Figure 3: Absolute Maximum Ratings

Electrical Specifications

TM Series GNSS Receiver Specifications						
Parameter	Symbol	Min.	Typ.	Max.	Units	Notes
Power Supply						
Operating Voltage	V_{CC}	3.0	3.3	4.3	VDC	
Supply Current	I_{CC}					
Peak				156	mA	1
Acquisition			28		mA	1
Tracking			20		mA	1
Standby			0.365		mA	1
Backup Battery Voltage	V_{BAT}	2.0		4.3	VDC	
Backup Battery Current	I_{BAT}		7		μA	2
VOUT Output Voltage	V_{OUT}	2.7	2.8	2.9	VDC	

TM Series GNSS Receiver Specifications						
Parameter	Symbol	Min.	Typ.	Max.	Units	Notes
VOUT Output Current	I_{OUT}			30	mA	1
Output Low Voltage	V_{OL}			0.4	VDC	
Output High Voltage	V_{OH}	2.4		3.3		
Output Low Current	I_{OL}		2.0		mA	
Output High Current	I_{OH}		2.0		mA	
Input Low Voltage	V_{IL}	-0.3		0.8	VDC	
Input High Voltage	V_{IH}	2.0		3.6	VDC	
Input Low Current	I_{IL}	-1		1	μA	3
Input High Current	I_{IH}	-1		1	μA	3
Antenna Port						
RF Impedance	R_{IN}		50		Ω	
Receiver Section						
Receiver Sensitivity						
Tracking			-164		dBm	
Cold Start			-147		dBm	
Acquisition Time						
Hot Start (Open Sky)			1		s	
Hot Start (Indoor)			30		s	
Cold Start			33		s	
Cold Start, AGPS			15		s	
Position Accuracy						
Autonomous			2.5		m	
SBAS			2.5		m	
1PPS Accuracy		-11		11	ns	4
Altitude				18,000	m	
Velocity				515	m/s	
Chipset	MediaTek MT3333					
Frequency	GPS, GALILEO, QZSS: L1 1575.42MHz, C/A code GLONASS: L1 1598.0625MHz ~ 1605.375MHz, C/A code					
Channels	99					
Update Rate	1Hz default, up to 10Hz					
Protocol Support	NMEA 0183 ver 4.10					

- $V_{CC} = 3.3V$, without active antenna, ephemeris prediction is off
- $V_{CC} = 0V$
- No pull-up or pull-down on the lines
- Relative to other TM Series modules, not to UTC time

Figure 4: Electrical Specifications

Pin Assignments

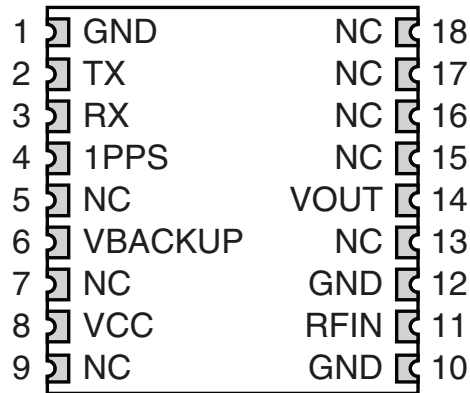

Figure 5: TM Series GNSS Receiver Pinout (Top View)

Pin Descriptions

Pin Descriptions			
Pin Number	Name	I/O	Description
1, 10, 12	GND	P	Ground
2	TX	O	Serial output (default NMEA)
3	RX	I	Serial input (default NMEA)
4	1PPS	O	1 Pulse Per Second (11nS accuracy)
5, 7, 9, 13, 15, 16, 17, 18	NC	-	No electrical connection
6	VBACKUP	P	Backup battery supply voltage. This line must be powered to enable the module.
8	VCC	P	Supply Voltage
11	RFIN	I	GNSS RF signal input
14	VOUT	O	Supply output for an active antenna

Figure 6: TM Series GNSS Receiver Pin Descriptions

A Brief Overview of GNSS

Global Navigation Satellite System is a generic term that covers any system of satellites that are used to determine location on Earth and have global coverage. As of 2013 there are two fully operational GNSS systems; NAVSTAR GPS operated by the United States and GLONASS operated by Russia. The European Union is building its satellite constellation for their Galileo system and China has started to expand their Beidou system into a global system called Compass.

The United States has the original GNSS system consisting of a nominal constellation of 24 satellites orbiting the earth at about 12,000 nautical miles in height. The pattern and spacing of the satellites allow at least four to be visible above the horizon from any point on the Earth. Russia's GLONASS system fell into disrepair after the collapse of the Soviet Union, but was recovered and fully restored in 2011.

The systems were originally intended for military applications such as ordinance delivery and troop movement. In 1994 when the NAVSTAR constellation was completed, the GPS signals were made available for civilian applications, primarily aircraft navigation.

Each satellite transmits low power radio signals which contain three different bits of information; a pseudorandom code identifying the satellite, ephemeris data which contains the current date and time as well as the satellite's precise orbit information, and the almanac data which tells where each satellite should be at any time throughout the day and its status.

A receiver times the signals sent by multiple satellites and calculates the distance to each satellite. If the position of each satellite is known, the receiver can use triangulation to determine its position anywhere on the earth. The receiver uses four satellites to solve for four unknowns; latitude, longitude, altitude, and time. If any of these factors is already known to the system, an accurate position (fix) can be obtained with fewer satellites in view. Tracking more satellites improves calculation accuracy.

A faster Time To First Fix (TTFF) is possible if satellite information is stored in the receiver. If the receiver knows some of this information, then it can accurately predict satellite positions before acquiring an updated position fix. For example, aircraft or marine navigation equipment may have other means of determining altitude, so the GPS receiver would only have to lock on to three satellites and calculate three equations to provide the first position fix after power-up.

Time To First Fix (TTFF)

TTFF is often broken down into three parts:

Cold: A cold start is when the receiver has no accurate knowledge of its position or time. This happens when the receiver's internal Real Time Clock (RTC) has not been running or it has no valid ephemeris or almanac data. In a cold start, the receiver takes up to 30 seconds to acquire its position.

Warm: A typical warm start is when the receiver has valid almanac and time data and has not significantly moved since its last valid position calculation. This happens when the receiver has been shut down for more than 2 hours, but still has its last position, time, and almanac saved in memory, and its RTC has been running. The receiver can predict the location of the current visible satellites and its location; however, it needs to wait for an ephemeris broadcast (every 30 seconds) before it can accurately calculate its position.

Hot: A hot start is when the receiver has valid ephemeris, time, and almanac data. In a hot start, the receiver takes 1 second to acquire its position. The time to calculate a fix in this state is sometimes referred to as Time to Subsequent Fix or TTTF.

Module Description

The TM Series GNSS Receiver module is based on the MediaTek MT3333 chipset, which consumes less power than competitive products while providing exceptional performance even in dense foliage and urban canyons. No external RF components are needed other than an antenna. The simple serial interface and industry standard NMEA protocol make integration of the TM Series into an end product extremely straightforward.

The module's high-performance RF architecture allows it to receive GNSS signals that are as low as -164dBm . The TM Series can track up to 33 satellites at the same time. Once locked onto the visible satellites, the receiver calculates the range to the satellites and determines its position and the precise time. It then outputs the data through a standard serial port using several standard NMEA protocol formats.

The GNSS core handles all of the necessary initialization, tracking, and calculations autonomously, so no programming is required. The RF section is optimized for low level signals, and requires no production tuning.

Backup Battery

The module is designed to work with a backup battery that keeps the SRAM memory and the RTC powered when the RF section and the main GPS core are powered down. This enables the module to have a faster Time To First Fix (TTFF) when it is powered back on. The memory and clock pull about $7\mu\text{A}$. This means that a small lithium battery is sufficient to power these sections. This significantly reduces the power consumption and extends the main battery life while allowing for fast position fixes when the module is powered back on.

The backup battery must be installed for the module to be enabled.

Power Supply Requirements

The module requires a clean, well-regulated power source. While it is preferable to power the unit from a battery, it can operate from a power supply as long as noise is less than 20mV . Power supply noise can significantly affect the receiver's sensitivity, therefore providing clean power to the module should be a high priority during design. Bypass capacitors should be placed as close as possible to the module. The values should be adjusted depending on the amount and type of noise present on the supply line.

The 1PPS Output

The 1PPS line outputs 1 pulse per second on the rising edge of the GNSS second when the receiver has an over-solved navigation solution from five or more satellites. The pulse has a duration of 100ms by default with the rising edge on the GNSS second. This line is low until the receiver acquires a 3D fix. The pulse width can be adjusted with a serial command.

The GNSS second is based on the atomic clocks in the satellites, which are monitored and set to Universal Time master clocks. This output and the time calculated from the satellite transmissions can be used as a clock feature in an end product with $\pm 1\text{ns}$ accuracy.

Hybrid Ephemeris Prediction (AGPS)

AGPS is where the receiver uses the ephemeris data broadcast by the satellites to calculate models of each visible satellite's future location. This allows the receiver to store up to 3 days' worth of ephemeris data and results in faster TTFF. Having this data reduces the cold start time to less than 15 seconds. Contact Linx for details on this.

Antenna Considerations

The TM Series module is designed to utilize a wide variety of external antennas. The module has a regulated power output which simplifies the use of GNSS antenna styles which require external power. This allows the designer great flexibility, but care must be taken in antenna selection to ensure optimum performance. For example, a handheld device may be used in many varying orientations so an antenna element with a wide and uniform pattern may yield better overall performance than an antenna element with high gain and a correspondingly narrower beam. Conversely, an antenna mounted in a fixed and predictable manner may benefit from pattern and gain characteristics suited to that application. Evaluating multiple antenna solutions in real-world situations is a good way to rapidly assess which will best meet the needs of your application.

For GNSS, the antenna should have good right hand circular polarization characteristics (RHCP) to match the polarization of the GNSS signals. Ceramic patches are the most commonly used style of antenna, but there are many different shapes, sizes and styles of antennas available. Regardless of the construction, they will generally be either passive or active types. Passive antennas are simply an antenna tuned to the correct frequency. Active antennas add a Low Noise Amplifier (LNA) after the antenna and before the module to amplify the weak GPS satellite signals.

For active antennas, a 300-ohm ferrite bead can be used to connect the VOUT line to the RFIN line. This bead prevents the RF from getting into the power supply, but allows the DC voltage onto the RF trace to feed into the antenna. A series capacitor inside the module prevents this DC voltage from affecting the bias on the module's internal LNA.

Maintaining a 50-ohm path between the module and antenna is critical. Errors in layout can significantly impact the module's performance. Please review the layout guidelines section carefully to become more familiar with these considerations.

Power Control

The TM Series GPS Receiver module offers several ways to control the module's power. A serial command puts the module into a low-power standby mode that consumes only 365 μ A of current. An external processor can be used to power the module on and off to conserve battery power.

In addition, the module includes a duty cycle mode where the module will power on for a configurable amount of time to obtain a position fix then power off for a configurable amount of time. In this way the module can handle all of the timing without any intervention from the external processor.

There are four times that are configured with duty cycle mode. The on time and standby times are the amount of times that the module is on and in standby in normal operation. There are also cold start on and standby times. These are used to keep the module on longer in the event of a cold start so that it can gather the required satellite data for a position fix. After this, the module uses the normal operation times.

In the event that the module's stored ephemeris data becomes invalid the module supports and extended receive time to gather the required data from the satellites. Figure 7 shows the power control times.

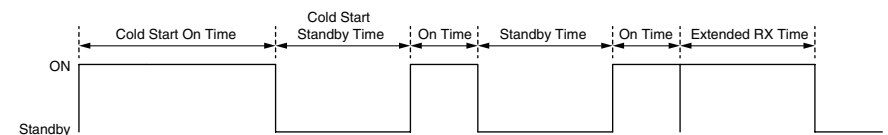

Figure 7: TM Series GNSS Receiver Power Control

The module supports MediaTek's proprietary AlwaysLocate™ mode. In this mode, the module automatically adapts the on and standby times to the current environmental conditions to balance position accuracy and power consumption. In this mode, any byte sent to the module triggers it to output the current position data.

Standby mode is configured by command 161. Extended receive time is configured by command 223. Command 225 configures which duty cycle mode is used.

Only enter standby mode after the module acquires a position fix.

Slow Start Time

The most critical factors in start time are current ephemeris data, signal strength and sky view. The ephemeris data describes the path of each satellite as they orbit the earth. This is used to calculate the position of a satellite at a particular time. This data is only usable for a short period of time, so if it has been more than a few hours since the last fix or if the location has significantly changed (a few hundred miles), then the receiver may need to wait for a new ephemeris transmission before a position can be calculated. The GNSS satellites transmit the ephemeris data every 30 seconds. Transmissions with a low signal strength may not be received correctly or be corrupted by ambient noise. The view of the sky is important because the more satellites the receiver can see, the faster the fix and the more accurate the position will be when the fix is obtained.

If the receiver is in a very poor location, such as inside a building, urban canyon, or dense foliage, then the time to first fix can be slowed. In very poor locations with poor signal strength and a limited view of the sky with outdated ephemeris data, this could be on the order of several minutes. In the worst cases, the receiver may need to receive almanac data, which describes the health and course data for every satellite in the constellation. This data is transmitted every 15 minutes. If a lock is taking a long time, try to find a location with a better view of the sky and fewer obstructions. Once locked, it is easier for the receiver to maintain the position fix.

Interfacing with NMEA Messages

Linux modules default to the NMEA protocol. Output messages are sent from the receiver on the TX line and input messages are sent to the receiver on the RX line. By default, output messages are sent once every second. Details of each message are described in the following sections.

The NMEA message format is as follows: <Message-ID + Data Payload + Checksum + End Sequence>. The serial data structure defaults to 9,600bps, 8 data bits, 1 start bit, 1 stop bit, and no parity. Each message starts with a \$ character and ends with a <CR> <LF>. All fields within each message are separated by a comma. The checksum follows the * character and is the last two characters, not including the <CR> <LF>. It consists of two hex digits representing the exclusive OR (XOR) of all characters between, but not including, the \$ and * characters. When reading NMEA output messages, if a field has no value assigned to it, the comma will still be placed following the previous comma. For example, {,04,,,,,2.0,} shows four empty fields between values 04 and 2.0. When writing NMEA input messages, all fields are required, none are optional. An empty field will invalidate the message and it will be ignored.

Reading NMEA output messages:

- Initialize a serial interface to match the serial data structure of the GPS receiver.
- Read the NMEA data from the TX pin into a receive buffer.
- Separate it into six buffers, one for each message type. Use the characters (\$) and <CR> <LF> as end points for each message.
- For each message, calculate the checksum as mentioned above to compare with the received checksum.
- Parse the data from each message using commas as field separators.
- Update the application with the parsed field values.
- Clear the receive buffer and be ready for the next set of messages.

Writing NMEA input messages:

- Initialize a serial interface to match the serial data structure of the GPS receiver.
- Assemble the message to be sent with the calculated checksum.
- Transmit the message to the receiver on the RX line.

NMEA Output Messages

The following sections outline the data structures of the various NMEA messages that are supported by the module. By default, the NMEA commands are output at 9,600bps, 8 data bits, 1 start bit, 1 stop bit, and no parity.

Six messages are output at a 1Hz rate by default. The ZDA message is supported, but disabled by default. These messages are shown in Figure 8.

NMEA Output Messages	
Name	Description
GGA	Contains the essential fix data which provide location and accuracy
GLL	Contains just position and time
GSA	Contains data on the Dilution of Precision (DOP) and which satellites are used
GSV	Contains the satellite location relative to the receiver and its signal to noise ratio. Each message can describe 4 satellites so multiple messages may be output depending on the number of satellites being tracked.
RMC	Contains the minimum data of time, position, speed and course
VTG	Contains the course and speed over the ground
ZDA	Contains the date and time

Figure 8: NMEA Output Messages

Some of the message IDs can change based on which system is used for the position fix. Figure 9 shows the different message identifiers based on the system that is used.

NMEA Output Message Identifiers						
System	GGA	GLL	GSA	GSV	RMC	VTG
GPS	GPGGA	GPGLL	GPGSA	GPGSV	GPRMC	GPVTG
GPS & GLONASS	GPGGA	GNGLL	GNGSA	GPGSV GLGSV	GPRMC or GNRMC ¹	GPVTG

1. The RMC output is GPRMC before a 3D fix, then changes to GNRMC after a fix is locked.

Figure 9: NMEA Output Message Identifiers

Details of each message and examples are given in the following sections.

GGA – Global Positioning System Fix Data

Figure 10 contains the values for the following example:

`$GPGGA,053740.000,2503.6319,N,12136.0099,E,1,08,1.1,63.8,M,15.2,M,,0000*64`

Global Positioning System Fix Data Example			
Name	Example	Units	Description
Message ID	\$GPGGA		GGA protocol header
UTC Time	053740.000		hhmmss.sss
Latitude	2503.6319		ddmm.mmmm
N/S Indicator	N		N=north or S=south
Longitude	12136.0099		dddmm.mmmm
E/W Indicator	E		E=east or W=west
Position Fix Indicator	1		See Figure 11
Satellites Used	08		Range 0 to 33
HDOP	1.1		Horizontal Dilution of Precision
MSL Altitude	63.8	meters	
Units	M	meters	
Geoid Separation	15.2	meters	
Units	M	meters	
Age of Diff. Corr.		second	Null fields when DGPS is not used
Diff. Ref. Station	0000		
Checksum	*64		
<CR> <LF>			End of message termination

Figure 10: Global Positioning System Fix Data Example

Position Indicator Values	
Value	Description
0	Fix not available or invalid
1	GPS SPS Mode, fix valid
2	Differential GPS, SPS Mode, fix valid
3–5	Not supported
6	Dead Reckoning Mode, fix valid (requires external hardware)

Figure 11: Position Indicator Values

GLL – Geographic Position – Latitude / Longitude

Figure 12 contains the values for the following example:

\$GPGLL,2503.6319,N,12136.0099,E,053740.000,A,A*52

Geographic Position – Latitude / Longitude Example			
Name	Example	Units	Description
Message ID	\$GPGLL		GLL protocol header (GNGLL or GPGLL)
Latitude	2503.6319		ddmm.mmmm
N/S Indicator	N		N=north or S=south
Longitude	12136.0099		dddmm.mmmm
E/W Indicator	E		E=east or W=west
UTC Time	053740.000		hhmmss.sss
Status	A		A=data valid or V=data not valid
Mode	A		A=autonomous, D=DGPS, N=Data not valid, R=Coarse Position, S=Simulator
Checksum	*52		
<CR> <LF>			End of message termination

Figure 12: Geographic Position – Latitude / Longitude Example

GSA – GNSS DOP and Active Satellites

Figure 13 contains the values for the following example:

\$GPGSA,A,3,24,07,17,11,28,08,20,04,,,,,2.0,1.1,1.7*35

GNSS DOP and Active Satellites Example			
Name	Example	Units	Description
Message ID	\$GPGSA		GSA protocol header (GPGSA for GPS or GNGSA for GLONASS)
Mode 1	A		See Figure 14
Mode 2	3		1=No fix, 2=2D, 3=3D
ID of satellite used	24		Sv on Channel 1
ID of satellite used	07		Sv on Channel 2
...			...
ID of satellite used			Sv on Channel N
PDOP	2.0		Position Dilution of Precision
HDOP	1.1		Horizontal Dilution of Precision
VDOP	1.7		Vertical Dilution of Precision
Checksum	*35		
<CR> <LF>			End of message termination

Figure 13: GNSS DOP and Active Satellites Example

Mode 1 Values

Value	Description
M	Manual – forced to operate in 2D or 3D mode
A	Automatic – allowed to automatically switch 2D/3D

Figure 14: Mode 1 Values

GSV – GNSS Satellites in View

Figure 15 contains the values for the following example:

\$GPGSV,3,1,12,28,81,285,42,24,67,302,46,31,54,354,,20,51,077,46*73
 \$GPGSV,3,2,12,17,41,328,45,07,32,315,45,04,31,250,40,11,25,046,41*75
 \$GPGSV,3,3,12,08,22,214,38,27,08,190,16,19,05,092,33,23,04,127,*7B
 \$GLGSV,2,1,07,76,71,201,44,65,57,041,40,75,48,028,39,72,27,108,39*68
 \$GLGSV,2,2,07,66,25,333,43,77,17,207,37,81,02,280,29*5C

GNSS Satellites in View Example

Name	Example	Units	Description
Message ID	\$GPGSV		GSV protocol header (GPGSV for GPS and GLGSV for GLONASS)
Total number of messages ¹	3		Range 1 to 6 (GPS) and 1 to 3 (GLONASS)
Message number ¹	1		Range 1 to 6 (GPS) and 1 to 3 (GLONASS)
Satellites in view	12		
Satellite ID	28		Channel 1 (Range 01 to 196)
Elevation	81	degrees	Channel 1 (Range 00 to 90)
Azimuth	285	degrees	Channel 1 (Range 000 to 359)
SNR (C/No)	42	dB-Hz	Channel 1 (Range 00 to 99, null when not tracking)
Satellite ID	20		Channel 2 (Range 01 to 196)
Elevation	51	degrees	Channel 2 (Range 00 to 90)
Azimuth	077	degrees	Channel 2 (Range 000 to 359)
SNR (C/No)	46	dB-Hz	Channel 2 (Range 00 to 99, null when not tracking).
Checksum	*73		
<CR> <LF>			End of message termination

1. Depending on the number of satellites tracked, multiple messages of GSV data may be required.

Figure 15: GNSS Satellites in View Example

RMC – Recommended Minimum Specific GNSS Data

Figure 16 contains the values for the following example:

\$GPRMC,053740.000,A,2503.6319,N,12136.0099,E,2.69,79.65,100106,,,A*53

Recommended Minimum Specific GNSS Data Example			
Name	Example	Units	Description
Message ID	\$GPRMC		RMC protocol header (GNRMC or GPRMC)
UTC Time	053740.000		hhmmss.sss
Status	A		A=data valid or V=data not valid
Latitude	2503.6319		ddmm.mmmm
N/S Indicator	N		N=north or S=south
Longitude	12136.0099		dddmm.mmmm
E/W Indicator	E		E=east or W=west
Speed over ground	2.69	knots	TRUE
Course over ground	79.65	degrees	
Date	100106		ddmmyy
Magnetic Variation		degrees	Not available, null field
Variation Sense			E=east or W=west (not shown)
Mode	A		A=autonomous, D=DGPS, E=DR, N=Data not valid, R=Coarse Position, S=Simulator
Checksum	*53		
<CR> <LF>			End of message termination

Figure 16: Recommended Minimum Specific GNSS Data Example

VTG – Course Over Ground and Ground Speed

Figure 17 contains the values for the following example:

\$GPVTG,79.65,T,,M,2.69,N,5.0,K,A*38

Course Over Ground and Ground Speed Example			
Name	Example	Units	Description
Message ID	\$GPVTG		VTG protocol header
Course over ground	79.65	degrees	Measured heading
Reference	T		TRUE
Course over ground		degrees	Measured heading (N/A, null field)
Reference	M		Magnetic
Speed over ground	2.69	knots	Measured speed
Units	N		Knots
Speed over ground	5.0	km/hr	Measured speed
Units	K		Kilometer per hour
Mode	A		A=autonomous, D=DGPS, N=Data not valid, R=Coarse Position, S=Simulator
Checksum	*38		
<CR> <LF>			End of message termination

Figure 17: Course Over Ground and Ground Speed Example

ZDA – Universal Time and Date

Figure 18 contains the values for the following example:

`$GPZDA,183746.000,22,08,2014,,*56`

Universal Time and Date Example			
Name	Example	Units	Description
Message ID	\$GPZDA		ZDA protocol header
UTC Time	183746.000		hhmmss.sss
Day	22		01 to 31
Month	08		01 to 12
Year	2014		1980 to 2079
Local Zone Hour			Offset from UTC; set to null
Local Zone Minutes			Offset from UTC; set to null
Checksum	*56		
<CR> <LF>			End of message termination

Figure 18: Universal Time and Date Example

Start-up Response

The module outputs a message when it starts up to indicate its state. The normal start-up message is shown below and the message formatting is shown in Figure 19.

`$PMTK010,001*2E<CR><LF>`

Start-up Response Example		
Name	Example	Description
Message ID	\$PMTK010	Message header
Message	MSG	System Message 0 = Unknown 1 = Start-up 2 = Notification for the host supporting EPO 3 = Transition to Normal operation is successful
Checksum	CKSUM	
End Sequence	<CR> <LF>	End of message termination

Figure 19: Start-up Response Example

PMTKLSC - Leap Second Change

Figure 10 contains the values for the following example:

`$PMTKLSC,17,0,17*42`

Leap Second Change Example			
Name	Example	Units	Description
Message ID	\$PMTKLSC		Leap Second Change protocol header
Current	17		Current leap second
Indicator	0		Leap indicator, 1 = updated from broadcast data
Next	17		Next leap second
Checksum	*42		
<CR> <LF>			End of message termination

Figure 20: Leap Second Change Example

Once the leap second has been updated from the satellite transmissions, the indicator field changes to 1. At this point, the indicator is accurate.

`$PMTKLSC,17,1,17*43`

Input Messages

The following outlines the serial commands input into the module for configuration. There are 3 types of input messages: commands, writes and reads. The module outputs a response for each input message.

The commands are used to change the operating state of the module. The writes are used to change the module's configuration and the reads are used to read out the current configuration. Messages are formatted as shown in Figure 21. All fields in each message are separated by a comma.

Serial Data Structure		
Name	Example	Description
Start Sequence	\$PMTK	
Message ID	<MID>	Message Identifier consisting of three numeric characters.
Payload	DATA	Message specific data.
Checksum	CKSUM	CKSUM is a two-hex character checksum as defined in the NMEA specification, NMEA-0183 Standard for Interfacing Marine Electronic Devices. Checksums are required on all input messages.
End Sequence	<CR> <LF>	Each message must be terminated using Carriage Return (CR) Line Feed (LF) (\r\n, 0x0D0A) to cause the receiver to process the input message. They are not printable ASCII characters, so are omitted from the examples.

Figure 21: Serial Data Structure

Figure 22 shows the input commands.

Input Commands	
Name	Description
101	Hot Re-start
102	Warm Re-start
103	Cold Re-start
104	Restore Default Configuration
161	Standby Mode
220	Position Fix Interval
223	Ephemeris Data Receive Time
225	Receiver Duty Cycle
251	Serial Port Baud Rate
255	Sync 1PPS and NMEA Messages
256	Set Timing Product
257	Set Tunnel Scenario
285	1PPS Configuration
286	Enable Active Interference Cancellation
875	Enable Leap Second Change Message

Figure 22: Input Commands

The write and read messages are shown in Figure 23. A write message triggers an acknowledgement from the module. A read message triggers a response message containing the requested information.

Input Write and Read Messages			
Description	Write ID	Read ID	Response ID
DGPS Source	301	401	501
SBAS Enable	313	413	513
NMEA Output Messages	314	414	514
Set Datum	330	430	530
GNSS Search System	353	—	—
Static Navigation Threshold	386	447	527
Enable Ephemeris Prediction	869	869	869

Figure 23: Input Write and Read Messages

The module responds to commands with response messages. The acknowledge message is formatted as shown in Figure 24.

Acknowledge Message		
Name	Example	Description
Start Sequence	\$PMTK	
Message ID	001	Acknowledge Identifier
Command	CMD	The command that triggered the acknowledge
Flag	Flg	Flag indicating the outcome of the command 0 = Invalid Command 1 = Unsupported Command 2 = Valid command, but action failed 3 = Valid command and action succeeded
Checksum	CKSUM	CKSUM is a two-hex character checksum as defined in the NMEA specification, NMEA-0183 Standard for Interfacing Marine Electronic Devices. Checksums are required on all input messages.
End Sequence	<CR> <LF>	Each message must be terminated using Carriage Return (CR) Line Feed (LF) (\r\n, 0x0D0A) to cause the receiver to process the input message. They are not printable ASCII characters, so are omitted from the examples.

Figure 24: Acknowledge Message

101 – Hot Re-start

This command instructs the module to conduct a hot re-start using all of the data stored in memory. Periodic mode and static navigation settings are returned to default when this command is executed.

```
$PMTK101*32<CR><LF>
```

102 – Warm Re-start

This command instructs the module to conduct a warm re-start that does not use the saved ephemeris data. Periodic mode and static navigation settings are returned to default when this command is executed.

```
$PMTK102*31<CR><LF>
```

103 – Cold Re-start

This command instructs the module to conduct a cold re-start that does not use any of the data from memory. Periodic mode and static navigation settings are returned to default when this command is executed.

```
$PMTK103*30<CR><LF>
```

104 – Restore Default Configuration

This command instructs the module to conduct a cold re-start and return all configurations to the factory default settings.

```
$PMTK104*37<CR><LF>
```

161 – Standby Mode

This command instructs the module to enter a low power standby mode. Any activity on the RX line wakes the module. Only enter standby mode after the module acquires a position fix.

```
$PMTK161,0*28<CR><LF>
```

The module outputs the startup message when it wakes up.

```
$PMTK010,001*2E<CR><LF>
```

220 – Position Fix Interval

This command sets the position fix interval. This is the time between when the module calculates its position.

Position Fix Interval Command and Response					
Command					
Start	Msg ID	Interval	Checksum	End	
\$PMTK	220	,lval	*Cksum	<CR><LF>	
Response					
Start	Msg ID	CMD	Flag	Checksum	End
\$PMTK	001	,220	,Flg	*Cksum	<CR><LF>

Figure 25: Position Fix Interval Command and Response

lval = the interval time in milliseconds.

The interval must be larger than 100ms. Faster rates require that the baud rate be increased, the number of messages that are output be decreased or both. The module automatically calculates the required data bandwidth and returns an action failed response (Flg = 2) if the interval is faster than the module can output all of the required messages at the current baud rate. The following example sets the interval to 1 second.

```
$PMTK220,1000*1F<CR><LF>
```

It is recommended to use interval rates of 100ms, 200ms, 500ms, 1,000ms and 2,000ms. Although permissible, non-standard intervals are not guaranteed or recommended.

223 – Extended Receive Time

This command extends the amount of time that the receiver is on when in duty cycle mode. This allows the module to refresh its stored ephemeris data by staying awake until it received the data from the satellites.

Extended Receive Time Command and Response							
Command							
Start	Msg ID	SV	On Time	Extend Time	Extend Gap	Checksum	End
\$PMTK	223	,SV	,SNR	,EXT	,EXG	*Cksum	<CR><LF>
Response							
Start	Msg ID	CMD	Flag	Checksum	End		
\$PMTK	001	,223	,Flg	*Cksum	<CR><LF>		

Figure 26: Extended Receive Time Command and Response

Extended Receive Time Fields	
Field	Description
SV	The minimum number of satellites required to have valid ephemeris data. The extend time triggers when the number of satellites with valid ephemeris data falls below this number. The value is 1 to 4.
SNR	The minimum SNR of the satellites used for a position fix. The module will not wait for ephemeris data from any satellites whose SNR is below this value.
EXT	The extended time in ms to stay on to receive ephemeris data. This value can range from 40000 to 180000.
EXG	The minimum time in ms between a subsequent extended receive period. This value can range from 0 to 3600000.

Figure 27: Extended Receive Time Fields

The following example configures an extended on time to trigger if less than 1 satellite has valid ephemeris data. The satellite must have a signal to noise ratio higher than 30dB-Hz in order to be used. The module will stay on for 180,000ms and will have a gap time of 60,000ms.

```
$PMTK223,1,30,180000,60000*16<CR><LF>
```

225 – Receiver Duty Cycle

This command places the module into a duty cycle where it stays on for a period of time and calculates its position then goes to sleep for a period of time. This conserves battery power without the need for an external microcontroller to manage the timing.

Receiver Duty Cycle Command and Response									
Command									
Start	Msg ID	Mode	On Time	Standby Time	Cold On	Cold Sleep	Checksum	End	
\$PMTK	225	,Mde	,TO	,TS	,CO	,CS	*Cksum	<CR><LF>	
Response									
Start	Msg ID	CMD	Flag	Checksum	End				
\$PMTK	001	,225	,Flg	*Cksum	<CR><LF>				

Figure 28: Receiver Duty Cycle Command and Response

Receiver Duty Cycle Fields	
Field	Description
Mde	Operation Mode 0 = Normal Mode 2 = Duty Cycle Mode 8 = AlwaysLocate™
TO	Receiver on time (ms)
TS	Receiver standby time (ms)
CO	Receiver on time in the event of a cold start (ms). Allows more time for the module to receive ephemeris data in the event of a cold start.
CS	Receiver off time in the event of a cold start (ms). Allows more time for the module to receive ephemeris data in the event of a cold start.
CO and CS can be null values. In this case the module uses the TO and TS values.	

Figure 29: Receiver Duty Cycle Fields

This example sets the mode to duty cycle with an on time of 3s, and off time of 12s, a cold start on time of 18s and a cold start off time of 72s.

```
$PMTK225,2,3000,12000,18000,72000*15<CR><LF>
```

The following example sets the mode to normal operation.

```
$PMTK225,0*2B<CR><LF>
```

The following example sets the module into AlwaysLocate™ mode.

```
$PMTK225,8*23<CR><LF>
```

251 – Serial Port Baud Rate

This command sets the serial port baud rate.

Serial Port Baud Rate Command and Response					
Command					
Start	Msg ID	Rate	Checksum	End	
\$PMTK	251	,Rate	*Cksum	<CR><LF>	
Response					
Start	Msg ID	CMD	Flag	Checksum	End
\$PMTK	001	,251	,Flg	*Cksum	<CR><LF>

Figure 30: Serial Port Baud Rate Command and Response

Rate = serial port baud rate

0 = default setting

4800

9600

14400

19200

38400

57600

115200

The following example sets the baud rate to 57,600bps.

```
$PMTK251,57600*2C<CR><LF>
```

255 – Sync 1PPS and NMEA Messages

This command enables or disables synchronization between the 1PPS pulse and the NMEA messages. When enabled, the beginning of the NMEA message on the UART is fixed to between 465 and 485ms after the rising edge of the 1PPS pulse. The NMEA message describes the position and time as of the rising edge of the 1PPS pulse.

Sync 1PPS and NMEA Messages Command and Response					
Command					
Start	Msg ID	Enable	Checksum	End	
\$PMTK	255	,Enable	*Cksum	<CR><LF>	
Response					
Start	Msg ID	CMD	Flag	Checksum	End
\$PMTK	001	,255	,Flg	*Cksum	<CR><LF>

Figure 31: Sync 1PPS and NMEA Messages Command and Response

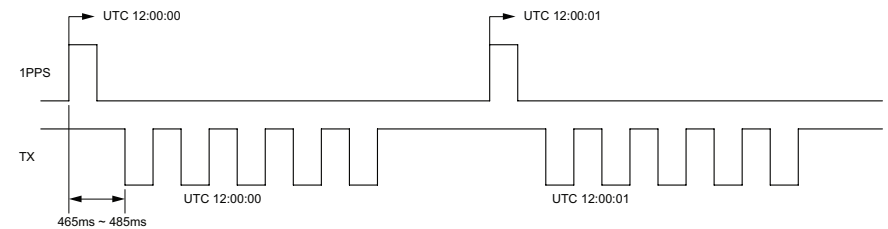

Figure 32: 1PPS and NMEA Message Synchronization

This is only supported at a 1Hz NMEA message rate. It is disabled by default. If all six NMEA messages are output, the serial port baud rate should be between 19,200 and 115,200bps to ensure stable synchronization.

The following examples show the use of this command.

```
Enable Sync: $PMTK255,1*2D<CR><LF>
```

```
Disable Sync: $PMTK255,0*2C<CR><LF>
```

256 – Set Timing Product

This command enables or disables the timing product. The timing product improves the accuracy of the 1PPS pulse relative to other modules.

Set Timing Product Command and Response					
Command					
Start	Msg ID	Enable	Checksum	End	
\$PMTK	256	,Enable	*Cksum	<CR><LF>	
Response					
Start	Msg ID	CMD	Flag	Checksum	End
\$PMTK	001	,256	,Flg	*Cksum	<CR><LF>

Figure 33: Set Timing Product Command and Response

This command needs to be sent again after hot, warm or cold starts or after waking from standby mode.

The following examples show the use of this command.

Enable Timing Product: `$PMTK256,1*2E<CR><LF>`

Disable Timing Product: `$PMTK256,0*2F<CR><LF>`

The set timing protocol configuration returns to the default values after a reset or restart.

257 – Set Tunnel Scenario

This command enables a fast time to first fix or high position accuracy when emerging from a tunnel.

Set Tunnel Scenario Command and Response					
Command					
Start	Msg ID	Type	Checksum	End	
\$PMTK	257	,Type	*Cksum	<CR><LF>	
Response					
Start	Msg ID	CMD	Flag	Checksum	End
\$PMTK	001	,257	,Flg	*Cksum	<CR><LF>

Figure 34: Set Tunnel Scenario Command and Response

Type = Type of position fix

0 = Fast TTFF

1 = High Accuracy (default)

The following examples show the use of this command.

Enable fast TTFF: `$PMTK257,0*2E<CR><LF>`

Enable high accuracy: `$PMTK257,1*2F<CR><LF>`

285 – 1PPS Configuration

This command configures the 1PPS output.

1PPS Configuration Command and Response					
Command					
Start	Msg ID	Type	Pulse Width	Checksum	End
\$PMTK	285	,Type	,Width	*Cksum	<CR><LF>
Response					
Start	Msg ID	CMD	Flag	Checksum	End
\$PMTK	001	,285	,Flg	*Cksum	<CR><LF>

Figure 35: 1PPS Configuration Messages Command and Response

Figure 36 shows the Type values.

1PPS Configuration Type Values	
Value	Description
0	Disable
1	After the first fix
2	3D fix only (default)
3	2D/3D fix only
4	Always

Figure 36: 1PPS Configuration Type Values

The Width field is the width of the 1PPS pulse in milliseconds. The max width is 900ms at a 1Hz NMEA message rate. The default is 100ms.

These configurations are maintained during hot and warm starts, but are lost on cold starts and restore to factory defaults.

Set the 1PPS to activate after a 3D fix and have a 10ms pulse width.

```
$PMTK285,2,10*0E<CR><LF>
```

Set the 1PPS to activate after a 3D fix and have a 900ms pulse width.

```
$PMTK285,2,900*36<CR><LF>
```

286 – Enable Active Interference Cancellation

This command enables or disables active interference cancellation. This feature helps remove jamming and narrow-band interference to enable a position fix.

Enable Active Interference Cancellation Command and Response					
Command					
Start	Msg ID	Enable	Checksum	End	
\$PMTK	286	,Enable	*Cksum	<CR><LF>	
Response					
Start	Msg ID	CMD	Flag	Checksum	End
\$PMTK	001	,286	,Flg	*Cksum	<CR><LF>

Figure 37: Enable Active Interference Cancellation Messages Command and Response

By default, this is enabled after the first fix is acquired.

The following examples show the use of this command.

```
Enable: $PMTK286,1*23<CR><LF>
```

```
Disable: $PMTK286,0*22<CR><LF>
```

875 – Enable PMTKLSC Message

This command enables or disables the Leap Second Change message.

Enable PMTKLSC Message Command and Response					
Command					
Start	Msg ID	CmdType	Enable	Checksum	End
\$PMTK	875	,CmdType	,Enable	*Cksum	<CR><LF>
Set Response					
Start	Msg ID	CMD	Flag	Checksum	End
\$PMTK	001	,875	,Flg	*Cksum	<CR><LF>
Query Response					
Start	Msg ID	CmdType	Enable	Checksum	End
\$PMTK	875	,2	,Enable	*Cksum	<CR><LF>

Figure 38: Sync 1PPS and NMEA Messages Command and Response

CmdType Values	
Value	Description
0	Query
1	Set
2	Result of the Query Operation

Figure 39: CmdType Values

Enable Values	
Value	Description
0	Message Disabled
1	Message Enabled

Figure 40: CmdType Values

The following examples show the use of this command.

Enable PMTKLSC: `$PMTK875,1,1*38<CR><LF>`

Disable PMTKLSC: `$PMTK875,1,0*39<CR><LF>`

Query PMTKLSC: `$PMTK875,0*24<CR><LF>`

Query Response: `$PMTK875,2,0*3A<CR><LF>` (Message disabled)

DGPS Source

This enables or disables DGPS mode and configures its source.

DGPS Source Command and Response					
Write Message					
Start	Msg ID	Mode	Checksum	End	
\$PMTK	301	,Mode	*Cksum	<CR><LF>	
Acknowledge Response Message					
Start	Msg ID	CMD	Flag	Checksum	End
\$PMTK	001	,301	,Flg	*Cksum	<CR><LF>
Read Message					
Start	Msg ID	Checksum	End		
\$PMTK	401	*37	<CR><LF>		
Response Message					
Start	Msg ID	Mode	Checksum	End	
\$PMTK	501	,Mode	*Cksum	<CR><LF>	

Figure 41: DGPS Source Command and Response

Mode = DGPS source mode

0 = No DGPS source

1 = RTCM

2 = WAAS

Differential Global Positioning System (DGPS) enhances GPS by using fixed, ground-based reference stations that broadcast the difference between the positions indicated by the satellite systems and the known fixed positions. The Radio Technical Commission for Maritime Services (RTCM) is an international standards organization that has a standard for DGPS. Wide Area Augmentation System (WAAS) is maintained by the FAA to improve aircraft navigation. This setting automatically switches among WAAS, EGNOS, MSAS and GAGAN when detected in covered regions

The following example sets the DGPS source to RTCM.

```
$PMTK301,1*2D<CR><LF>
```

The following example reads the current DGPS source and the module responds with the DGPS source as RTCM.

```
$PMTK401*37<CR><LF>
```

```
$PMTK501,1*2B<CR><LF>
```

Set Datum

This configures the current datum that is used.

Set Datum Command and Response					
Write Message					
Start	Msg ID	Datum	Checksum	End	
\$PMTK	330	,Datum	*Cksum	<CR><LF>	
Acknowledge Response Message					
Start	Msg ID	CMD	Flag	Checksum	End
\$PMTK	001	,330	,Flg	*Cksum	<CR><LF>
Read Message					
Start	Msg ID	Checksum	End		
\$PMTK	430	*35	<CR><LF>		
Response Message					
Start	Msg ID	Datum	Checksum	End	
\$PMTK	530	,Datum	*Cksum	<CR><LF>	

Figure 44: Set Datum Command and Response

Datum = the datum number to be used.

Reference datums are data sets that describe the shape of the Earth based on a reference point. There are many regional datums based on a convenient local reference point. Different datums use different reference points, so a map used with the receiver output must be based on the same datum. WGS84 is the default world referencing datum.

The module supports 223 different datums. These are listed in Appendix A.

The following example sets the datum to WGS84.

```
$PMTK330,0*2E<CR><LF>
```

The following example reads the current datum and the module replies with datum 0, which is WGS84.

```
$PMTK430*35<CR><LF>
$PMTK530,0*28<CR><LF>
```

GNSS Search System

This configures the GNSS systems used to calculate position fixes.

GNSS Search System Command and Response										
Write Message										
Start	Msg ID	GPS	GLNS	GAL	GALF	BEI	Checksum	End		
\$PMTK	353	,GPS	,GLNS	,GAL	,GALF	,BEI	*Cksum	<CR><LF>		
Acknowledge Response Message										
Start	Msg ID	CMD	Flag	GPS	GLNS	GAL	GALF	BEI	Checksum	End
\$PMTK	001	,353	,Flg	,GPS	,GLNS	,GAL	,GALF	,BEI	*Cksum	<CR><LF>

Figure 45: GNSS Search System Command and Response

GPS = Search GPS satellites

0 = disabled, do not search GPS satellites

1 = enabled

GLNS = Search GLONASS satellites

0 = disabled, do not search GLONASS satellites

1 = enabled

GAL = Search GALILEO satellites (not supported, set to 0)

GALF = Search GALILEO full mode satellites (not supported, set to 0)

BEI = Search Beidou satellites (not supported, set to 0)

The following example configures the module to only use GLONASS satellites.

```
$PMTK353,0,1,0,0,0*2A<CR><LF>
```

The following example configures the module to only use GPS satellites.

```
$PMTK353,1,0,0,0,0*2A<CR><LF>
```

The following example configures the module to use GPS and GLONASS satellites.

```
$PMTK353,1,1,0,0,0*2B<CR><LF>
```

Note: The Galileo and Beidou fields are added to modules with date code 1605 and later.

Static Navigation Threshold

This configures the speed threshold to trigger static navigation. If the measured speed is below the threshold then the module holds the current position and sets the speed to zero.

Static Navigation Threshold Command and Response					
Write Message					
Start	Msg ID	Thold	Checksum	End	
\$PMTK	386	,Thold	*Cksum	<CR><LF>	
Acknowledge Response Message					
Start	Msg ID	CMD	Flag	Checksum	End
\$PMTK	001	,386	,Flg	*Cksum	<CR><LF>
Read Message					
Start	Msg ID	Checksum	End		
\$PMTK	447	*35	<CR><LF>		
Response Message					
Start	Msg ID	Thold	Checksum	End	
\$PMTK	527	,Thold	*Cksum	<CR><LF>	

Figure 46: Static Navigation Threshold Command and Response

Thold = speed threshold, from 0 to 2.0m/s. 0 = disabled.

The following example sets the threshold to 1.2m/s.

```
$PMTK386,1.2*3E<CR><LF>
```

The following example reads the static navigation threshold and the module responds with 1.2m/s

```
$PMTK447*35<CR><LF>
$PMTK527,1.20*03<CR><LF>
```

The static navigation threshold configuration returns to the default values after a reset or restart.

Enable Ephemeris Prediction

This enables or disables the module's built-in ephemeris prediction.

Enable Ephemeris Prediction Command and Response					
Write Message					
Start	Msg ID	CMD	Enable	Checksum	End
\$PMTK	869	,1	,Enable	*Cksum	<CR><LF>
Acknowledge Response Message					
Start	Msg ID	CMD	Flag	Checksum	End
\$PMTK	001	,869	,Flg	*Cksum	<CR><LF>
Read Message					
Start	Msg ID	CMD	Enable	Checksum	End
\$PMTK	869	,0	,Enable	*Cksum	<CR><LF>
Response Message					
Start	Msg ID	CMD	Enable	Checksum	End
\$PMTK	869	,2	,Enable	*Cksum	<CR><LF>

Figure 47: Enable Ephemeris Prediction Command and Response

This message is formatted slightly differently from the other messages. The same Message ID is used for the read, write and response and the first payload field (CMD) indicates which type of message it is. A 0 is a read, a 1 is a write and a 2 is a response to a read.

Enable = enable ephemeris prediction
 0 = disabled
 1 = enabled

The following example enables prediction.

```
$PMTK869,1,1*35<CR><LF>
```

The following example reads the configuration.

```
$PMTK869,0*29<CR><LF>
```

The module responds with the first example if prediction is disabled and the second if it is enabled.

```
$PMTK869,2,0*37<CR><LF>
$PMTK869,2,1*36<CR><LF>
```

Typical Applications

Figure 48 shows the TM Series GNSS receiver in a typical application using a passive antenna.

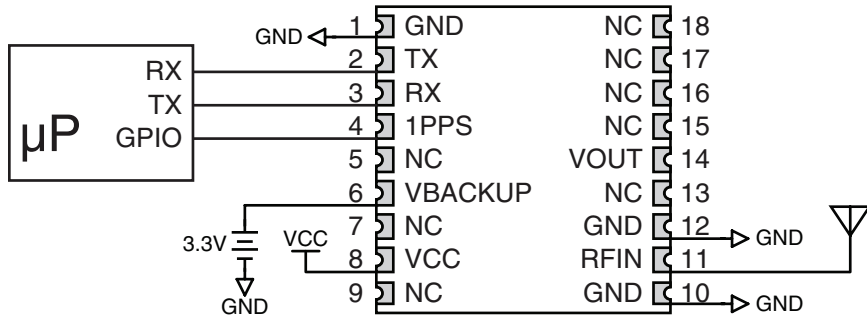

Figure 48: Circuit Using the TM Series Module with a Passive Antenna

A microcontroller UART is connected to the receiver's UART for passing data and commands. A 3.3V coin cell battery is connected to the VBACKUP line to provide power to the module's memory when main power is turned off.

Figure 49 shows the module using an active antenna.

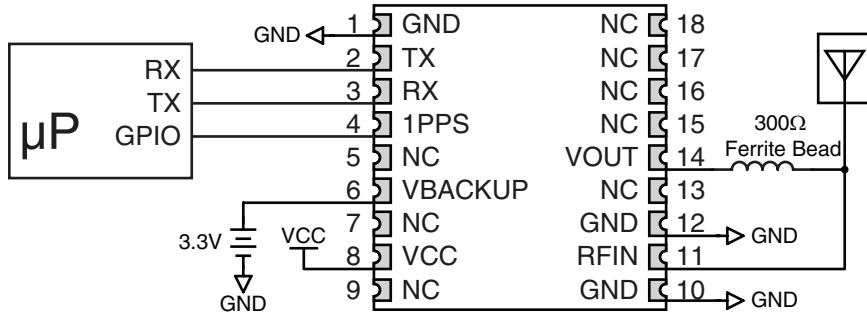

Figure 49: Circuit Using the TM Series Module with a an Active Antenna

A 300Ω ferrite bead is used to put power from VOUT onto the antenna line to power the active antenna.

Microstrip Details

A transmission line is a medium whereby RF energy is transferred from one place to another with minimal loss. This is a critical factor, especially in high-frequency products like Linx RF modules, because the trace leading to the module's antenna can effectively contribute to the length of the antenna, changing its resonant bandwidth. In order to minimize loss and detuning, some form of transmission line between the antenna and the module should be used unless the antenna can be placed very close (<1/8in) to the module. One common form of transmission line is a coax cable and another is the microstrip. This term refers to a PCB trace running over a ground plane that is designed to serve as a transmission line between the module and the antenna. The width is based on the desired characteristic impedance of the line, the thickness of the PCB and the dielectric constant of the board material. For standard 0.062in thick FR-4 board material, the trace width would be 111 mils. The correct trace width can be calculated for other widths and materials using the information in Figure 50 and examples are provided in Figure 51. Software for calculating microstrip lines is also available on the Linx website.

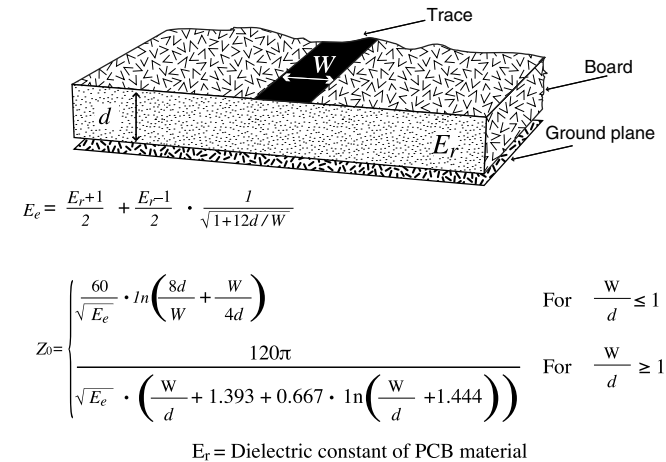

Figure 50: Microstrip Formulas

Example Microstrip Calculations			
Dielectric Constant	Width/Height Ratio (W/d)	Effective Dielectric Constant	Characteristic Impedance (Ω)
4.80	1.8	3.59	50.0
4.00	2.0	3.07	51.0
2.55	3.0	2.12	48.0

Figure 51: Example Microstrip Calculations

Board Layout Guidelines

The module's design makes integration straightforward; however, it is still critical to exercise care in PCB layout. Failure to observe good layout techniques can result in a significant degradation of the module's performance. A primary layout goal is to maintain a characteristic 50-ohm impedance throughout the path from the antenna to the module. Grounding, filtering, decoupling, routing and PCB stack-up are also important considerations for any RF design. The following section provides some basic design guidelines which may be helpful.

During prototyping, the module should be soldered to a properly laid-out circuit board. The use of prototyping or "perf" boards will result in poor performance and is strongly discouraged.

The module should, as much as reasonably possible, be isolated from other components on your PCB, especially high-frequency circuitry such as crystal oscillators, switching power supplies, and high-speed bus lines.

When possible, separate RF and digital circuits into different PCB regions. Make sure internal wiring is routed away from the module and antenna, and is secured to prevent displacement.

Do not route PCB traces directly under the module. There should not be any copper or traces under the module on the same layer as the module, just bare PCB. The underside of the module has traces and vias that could short or couple to traces on the product's circuit board.

The Pad Layout section shows a typical PCB footprint for the module. A ground plane (as large and uninterrupted as possible) should be placed on a lower layer of your PC board opposite the module. This plane is essential for creating a low impedance return for ground and consistent stripline performance.

Use care in routing the RF trace between the module and the antenna or connector. Keep the trace as short as possible. Do not pass under the module or any other component. Do not route the antenna trace on multiple PCB layers as vias will add inductance. Vias are acceptable for tying together ground layers and component grounds and should be used in multiples.

Each of the module's ground pins should have short traces tying immediately to the ground plane through a via.

Bypass caps should be low ESR ceramic types and located directly adjacent to the pin they are serving.

A 50-ohm coax should be used for connection to an external antenna. A 50-ohm transmission line, such as a microstrip, stripline or coplanar waveguide should be used for routing RF on the PCB. The Microstrip Details section provides additional information.

In some instances, a designer may wish to encapsulate or "pot" the product. There is a wide variety of potting compounds with varying dielectric properties. Since such compounds can considerably impact RF performance and the ability to rework or service the product, it is the responsibility of the designer to evaluate and qualify the impact and suitability of such materials.

Pad Layout

The pad layout diagram in Figure 52 is designed to facilitate both hand and automated assembly.

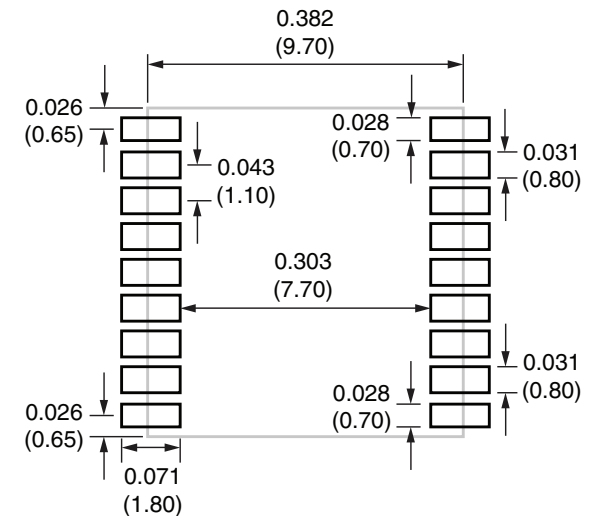

Figure 52: Recommended PCB Layout

Production Guidelines

The module is housed in a hybrid SMD package that supports hand and automated assembly techniques. Since the modules contain discrete components internally, the assembly procedures are critical to ensuring the reliable function of the modules. The following procedures should be reviewed with and practiced by all assembly personnel.

Hand Assembly

Pads located on the bottom of the module are the primary mounting surface (Figure 53). Since these pads are inaccessible during mounting, castellations that run up the side of the module have been provided to facilitate solder wicking to the module's underside. This allows for very

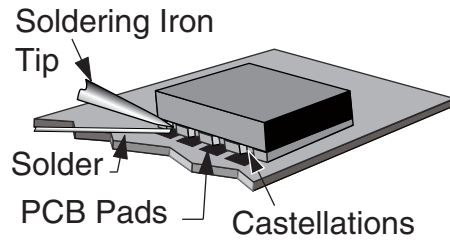

Figure 53: Soldering Technique

quick hand soldering for prototyping and small volume production. If the recommended pad guidelines have been followed, the pads will protrude slightly past the edge of the module. Use a fine soldering tip to heat the board pad and the castellation, then introduce solder to the pad at the module's edge. The solder will wick underneath the module, providing reliable attachment. Tack one module corner first and then work around the device, taking care not to exceed the times in Figure 54.

Warning: Pay attention to the absolute maximum solder times.

Absolute Maximum Solder Times

Hand Solder Temperature: +427°C for 10 seconds for lead-free alloys

Reflow Oven: +240°C max (see Figure 55)

Figure 54: Absolute Maximum Solder Times

Automated Assembly

For high-volume assembly, the modules are generally auto-placed. The modules have been designed to maintain compatibility with reflow processing techniques; however, due to their hybrid nature, certain aspects of the assembly process are far more critical than for other component types. Following are brief discussions of the three primary areas where caution must be observed.

Reflow Temperature Profile

The single most critical stage in the automated assembly process is the reflow stage. The reflow profile in Figure 55 should not be exceeded because excessive temperatures or transport times during reflow will irreparably damage the modules. Assembly personnel need to pay careful attention to the oven's profile to ensure that it meets the requirements necessary to successfully reflow all components while still remaining within the limits mandated by the modules. The figure below shows the recommended reflow oven profile for the modules.

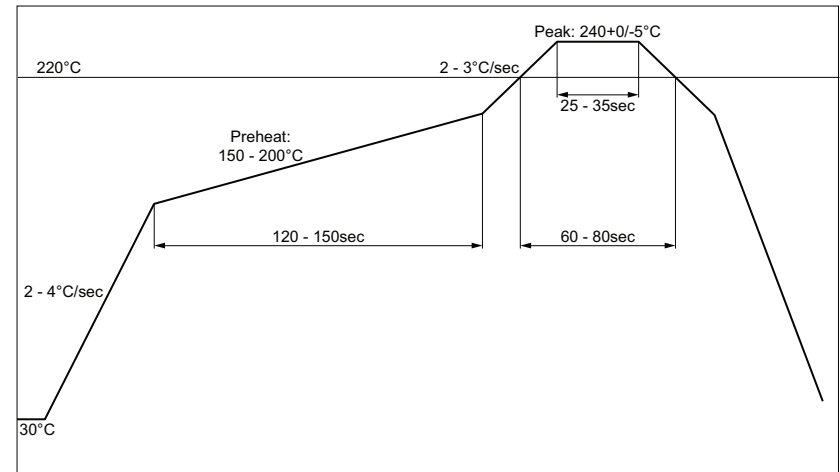

Figure 55: Maximum Reflow Temperature Profile

Shock During Reflow Transport

Since some internal module components may reflow along with the components placed on the board being assembled, it is imperative that the modules not be subjected to shock or vibration during the time solder is liquid. Should a shock be applied, some internal components could be lifted from their pads, causing the module to not function properly.

Washability

The modules are wash-resistant, but are not hermetically sealed. Linx recommends wash-free manufacturing; however, the modules can be subjected to a wash cycle provided that a drying time is allowed prior to applying electrical power to the modules. The drying time should be sufficient to allow any moisture that may have migrated into the module to evaporate, thus eliminating the potential for shorting damage during power-up or testing. If the wash contains contaminants, the performance may be adversely affected, even after drying.