



Chipsmall Limited consists of a professional team with an average of over 10 year of expertise in the distribution of electronic components. Based in Hongkong, we have already established firm and mutual-benefit business relationships with customers from,Europe,America and south Asia,supplying obsolete and hard-to-find components to meet their specific needs.

With the principle of “Quality Parts,Customers Priority,Honest Operation,and Considerate Service”,our business mainly focus on the distribution of electronic components. Line cards we deal with include Microchip,ALPS,ROHM,Xilinx,Pulse,ON,Everlight and Freescale. Main products comprise IC,Modules,Potentiometer,IC Socket,Relay,Connector.Our parts cover such applications as commercial,industrial, and automotives areas.

We are looking forward to setting up business relationship with you and hope to provide you with the best service and solution. Let us make a better world for our industry!



Contact us

Tel: +86-755-8981 8866 Fax: +86-755-8427 6832

Email & Skype: info@chipsmall.com Web: www.chipsmall.com

Address: A1208, Overseas Decoration Building, #122 Zhenhua RD., Futian, Shenzhen, China



The S-35190A is a CMOS 3-wire real-time clock IC which operates with the very low current consumption and in the wide range of operation voltage. The operation voltage is 1.3 V to 5.5 V so that the S-35190A can be used for various power supplies from main supply to backup battery. Due to the 0.25 μ A current consumption and wide range of power supply voltage at time keeping, the S-35190A makes the battery life longer. In the system which operates with a backup battery, the included free registers can be used as the function for user's backup memory. Users always can take back the information in the registers which is stored before power-off the main power supply, after the voltage is restored.

The S-35190A has the function to correct advance / delay of the clock data speed, in the wide range, which is caused by the oscillation circuit's frequency deviation. Correcting according to the temperature change by combining this function and a temperature sensor, it is possible to make a high precise clock function which is not affected by the ambient temperature.

■ Features

- Low current consumption: 0.25 μ A typ. ($V_{DD} = 3.0$ V, $T_a = +25^\circ\text{C}$)
- Wide range of operating voltage: 1.3 V to 5.5 V
- Built-in clock correction function
- Built-in free user register
- 3-wire (MICROWIRE) CPU interface
- Built-in alarm interrupter
- Built-in flag generator during detection of low power voltage or at power-on
- Auto calendar up to the year 2099, automatic leap year calculation function
- Built-in constant-voltage circuit
- Built-in 32.768 kHz crystal oscillator (C_d built in, C_g external)
- Lead-free, Sn 100%, halogen-free^{*1}

*1. Refer to "■ Product Name Structure" for details.

■ Applications

- Mobile game device
- Mobile AV device
- Digital still camera
- Digital video camera
- Electronic power meter
- DVD recorder
- TV, VCR
- Mobile phone, PHS
- Car navigation system

■ Packages

- 8-Pin SOP (JEDEC)
- 8-Pin TSSOP
- SNT-8A

■ Block Diagram

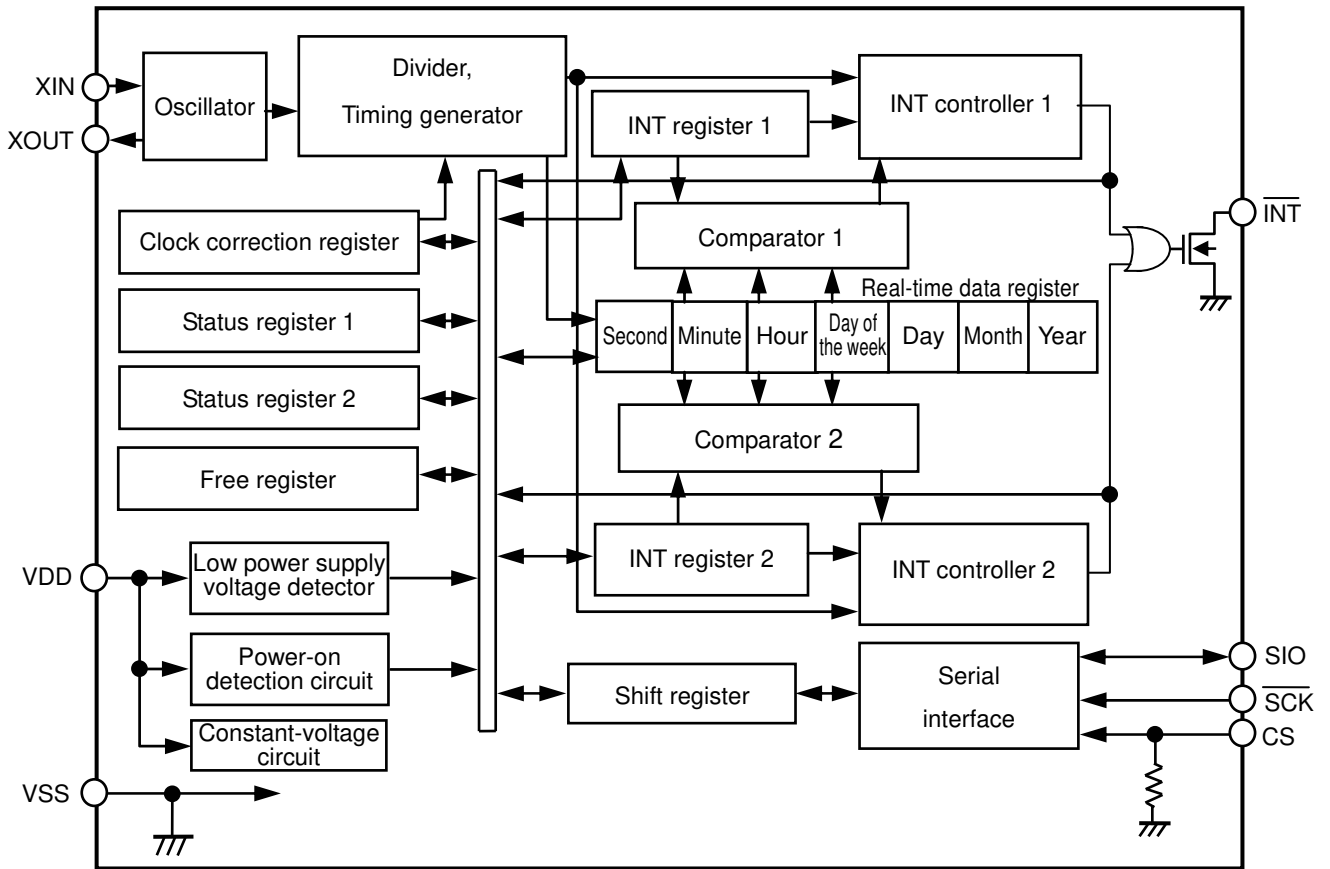
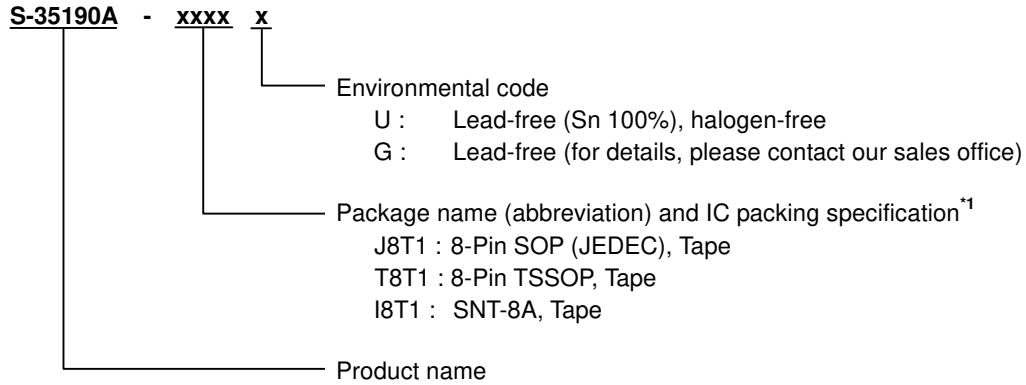

Figure 1

■ Product Name Structure

1. Product name



*1. Refer to the tape drawing.

2. Packages

Table 1 Package Drawing Codes

Package Name		Dimension	Tape	Reel	Land
8-Pin SOP (JEDEC)	Environmental code = G	FJ008-A-P-SD	FJ008-D-C-SD	FJ008-D-R-SD	-
	Environmental code = U	FJ008-A-P-SD	FJ008-D-C-SD	FJ008-D-R-S1	-
8-Pin TSSOP	Environmental code = G	FT008-A-P-SD	FT008-E-C-SD	FT008-E-R-SD	-
	Environmental code = U	FT008-A-P-SD	FT008-E-C-SD	FT008-E-R-S1	-
SNT-8A		PH008-A-P-SD	PH008-A-C-SD	PH008-A-R-SD	PH008-A-L-SD

Pin Configurations

1. 8-Pin SOP (JEDEC)

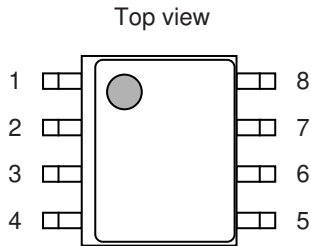

Figure 2 S-35190A-J8T1x

2. 8-Pin TSSOP

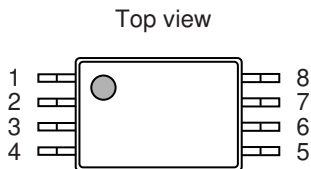

Figure 3 S-35190A-T8T1x

3. SNT-8A

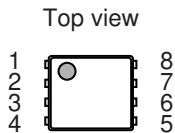

Figure 4 S-35190A-I8T1x

Table 2 List of Pins

Pin No	Symbol	Description	I/O	Configuration
1	$\overline{\text{INT}}$	Output pin for interrupt signal	Output	Nch open-drain output (no protective diode at VDD)
2	XOUT	Connection pin for crystal oscillator	—	—
3	XIN			
4	VSS	GND pin	—	—
5	CS	Input pin for chip select	Input	CMOS input (built-in pull-down resistor. no protective diode at VDD)
6	$\overline{\text{SCK}}$	Input pin for serial clock	Input	CMOS input (no protective diode at VDD)
7	SIO	I/O pin for serial data	Bi-directional	Nch open-drain output (no protective diode at VDD) CMOS input
8	VDD	Pin for positive power supply	—	—

Remark 1. x: G or U

2. Please select products of environmental code = U for Sn 100%, halogen-free products.

■ Pin Functions

1. CS (input for chip select) pin

This pin is to input chip select, has a pull-down resistor. Communication is available when this pin is in "H". If not using communication, set this pin "L" or open.

2. $\overline{\text{SCK}}$ (input for serial clock) pin

This pin is to input a clock pulse for serial interface. When the CS pin is in "H", the SIO pin inputs / outputs data by synchronizing with the clock pulse. When the CS pin is in "L" or open, the $\overline{\text{SCK}}$ pin does not accept inputting a clock pulse.

3. SIO (I/O for serial data) pin

This is a data input / output pin of serial interface. When the CS pin is in "H", the SIO pin inputs / outputs data by synchronizing with a clock pulse from the $\overline{\text{SCK}}$ pin. The status is in "High-Z" when the CS pin is in "L" or open, so that the S-35190A does not transmit data. Setting the CS pin to "H" level from "L" or open, this SIO pin goes in the input status so that it receives the command data. This pin has CMOS input and Nch open drain output.

4. XIN, XOUT (crystal oscillator connect) pin

Connect a crystal oscillator between XIN and XOUT.

5. $\overline{\text{INT}}$ (output for interrupt signal) pin

This pin outputs a signal of interrupt, or a clock pulse. By using the status register 2, users can select either of; alarm 1 interrupt, alarm 2 interrupt, output of user-set frequency, per-minute edge interrupt, minute-periodical interrupt 1, minute-periodical interrupt 2, or 32.768 kHz output. This pin has Nch open drain output.

6. VDD (positive power supply) pin

Connect this VDD pin with a positive power supply. Regarding the values of voltage to be applied, refer to "■ Recommended Operation Conditions".

7. VSS pin

Connect the VSS pin to GND.

■ Equivalent Circuits of Pins

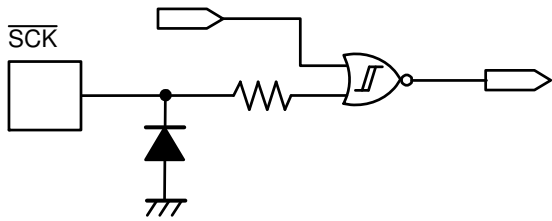

Figure 5 SCK pin

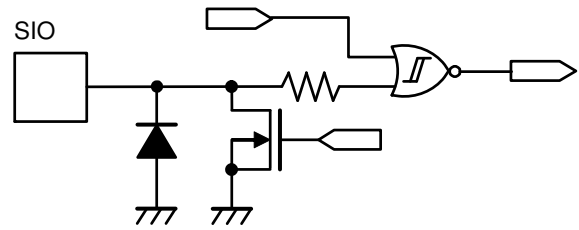

Figure 6 SIO pin

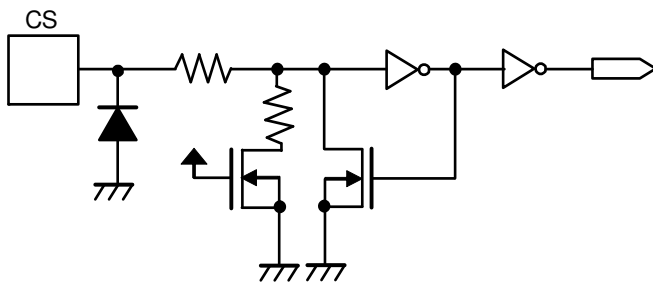

Figure 7 CS pin

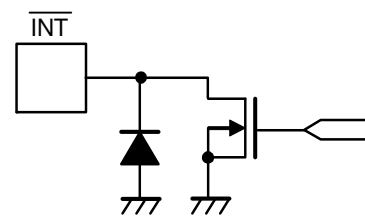

Figure 8 INT pin

■ Absolute Maximum Ratings

Table 3

Item	Symbol	Applied Pin	Absolute Maximum Rating	Unit
Power supply voltage	V_{DD}	–	$V_{SS} - 0.3$ to $V_{SS} + 6.5$	V
Input voltage	V_{IN}	CS, \overline{SCK} , SIO	$V_{SS} - 0.3$ to $V_{SS} + 6.5$	V
Output voltage	V_{OUT}	SIO, \overline{INT}	$V_{SS} - 0.3$ to $V_{SS} + 6.5$	V
Operating ambient temperature*1	T_{opr}	–	–40 to +85	°C
Storage temperature	T_{stg}	–	–55 to +125	°C

*1. Conditions with no condensation or frost. Condensation and frost cause short circuiting between pins, resulting in a malfunction.

Caution The absolute maximum ratings are rated values exceeding which the product could suffer physical damage. These values must therefore not be exceeded under any conditions.

■ Recommended Operation Conditions

Table 4

(V_{SS} = 0 V)

Item	Symbol	Condition	Min.	Typ.	Max.	Unit
Power supply voltage*1	V_{DD}	$T_a = -40^\circ\text{C}$ to $+85^\circ\text{C}$	1.3	3.0	5.5	V
Time keeping power supply voltage*2	V_{DDT}	$T_a = -40^\circ\text{C}$ to $+85^\circ\text{C}$	$V_{DET} - 0.15$	–	5.5	V
Crystal oscillator C_L value	C_L	–	–	6	7	pF

*1. The power supply voltage that allows communication under the conditions shown in **Table 9** of "■ AC Electrical Characteristics".

*2. The power supply voltage that allows time keeping. For the relationship with V_{DET} (low power supply voltage detection voltage), refer to "■ Characteristics (Typical Data)".

■ Oscillation Characteristics

Table 5

(T_a = +25°C, V_{DD} = 3.0 V, V_{SS} = 0 V, VT-200 crystal oscillator (C_L = 6 pF, 32.768 kHz) manufactured by Seiko Instruments Inc.)

Item	Symbol	Condition	Min.	Typ.	Max.	Unit
Oscillation start voltage	V_{STA}	Within 10 seconds	1.1	–	5.5	V
Oscillation start time	t_{STA}	–	–	–	1	s
IC-to-IC frequency deviation*1	δ_{IC}	–	–10	–	+10	ppm
Frequency voltage deviation	δV	$V_{DD} = 1.3$ V to 5.5 V	–3	–	+3	ppm/V
External capacitance	C_g	Applied to XIN pin	–	–	9.1	pF
Internal oscillation capacitance	C_d	Applied to XOUT pin	–	8	–	pF

*1. Reference value

■ **DC Electrical Characteristics**

Table 6 DC Characteristics (V_{DD} = 3.0 V)

(T_a = -40°C to +85°C, V_{SS} = 0 V, VT-200 crystal oscillator (C_L = 6 pF, 32.768 kHz, C₀ = 9.1 pF) manufactured by Seiko Instruments Inc.)

Item	Symbol	Applied Pin	Condition	Min.	Typ.	Max.	Unit
Current consumption 1	I _{DD1}	–	Out of communication	–	0.25	0.93	μA
Current consumption 2	I _{DD2}	–	During communication (\overline{SCK} = 100 kHz)	–	3.3	8	μA
Input current leakage 1	I _{IZH}	\overline{SCK} , SIO	V _{IN} = V _{DD}	-0.5	–	0.5	μA
Input current leakage 2	I _{IZL}	\overline{SCK} , SIO	V _{IN} = V _{SS}	-0.5	–	0.5	μA
Input current 1	I _{IH1}	CS	V _{IN} = V _{DD}	2	6	16	μA
Input current 2	I _{IH2}	CS	V _{IN} = 0.4 V	40	100	300	μA
Input current 3	I _{IH3}	CS	V _{IN} = 1.0 V	–	215	–	μA
Output current leakage 1	I _{OZH}	SIO, \overline{INT}	V _{OUT} = V _{DD}	-0.5	–	0.5	μA
Output current leakage 2	I _{OZL}	SIO, \overline{INT}	V _{OUT} = V _{SS}	-0.5	–	0.5	μA
Input voltage 1	V _{IH}	CS, \overline{SCK} , SIO	–	0.8 × V _{DD}	–	V _{SS} + 5.5	V
Input voltage 2	V _{IL}	CS, \overline{SCK} , SIO	–	V _{SS} - 0.3	–	0.2 × V _{DD}	V
Output current 1	I _{OL1}	\overline{INT}	V _{OUT} = 0.4 V	3	5	–	mA
Output current 2	I _{OL2}	SIO	V _{OUT} = 0.4 V	5	10	–	mA
Power supply voltage detection voltage	V _{DET}	–	–	0.65	1	1.35	V

Table 7 DC Characteristics (V_{DD} = 5.0 V)

(T_a = -40°C to +85°C, V_{SS} = 0 V, VT-200 crystal oscillator (C_L = 6 pF, 32.768 kHz, C₀ = 9.1 pF) manufactured by Seiko Instruments Inc.)

Item	Symbol	Applied Pin	Condition	Min.	Typ.	Max.	Unit
Current consumption 1	I _{DD1}	–	Out of communication	–	0.3	1.1	μA
Current consumption 2	I _{DD2}	–	During communication (\overline{SCK} = 100 kHz)	–	6	14	μA
Input current leakage 1	I _{IZH}	\overline{SCK} , SIO	V _{IN} = V _{DD}	-0.5	–	0.5	μA
Input current leakage 2	I _{IZL}	\overline{SCK} , SIO	V _{IN} = V _{SS}	-0.5	–	0.5	μA
Input current 1	I _{IH1}	CS	V _{IN} = V _{DD}	8	16	50	μA
Input current 2	I _{IH2}	CS	V _{IN} = 0.4 V	40	150	350	μA
Input current 3	I _{IH3}	CS	V _{IN} = 2.0 V	–	610	–	μA
Output current leakage 1	I _{OZH}	SIO, \overline{INT}	V _{OUT} = V _{DD}	-0.5	–	0.5	μA
Output current leakage 2	I _{OZL}	SIO, \overline{INT}	V _{OUT} = V _{SS}	-0.5	–	0.5	μA
Input voltage 1	V _{IH}	CS, \overline{SCK} , SIO	–	0.8 × V _{DD}	–	V _{SS} + 5.5	V
Input voltage 2	V _{IL}	CS, \overline{SCK} , SIO	–	V _{SS} - 0.3	–	0.2 × V _{DD}	V
Output current 1	I _{OL1}	\overline{INT}	V _{OUT} = 0.4 V	5	8	–	mA
Output current 2	I _{OL2}	SIO	V _{OUT} = 0.4 V	6	13	–	mA
Power supply voltage detection voltage	V _{DET}	–	–	0.65	1	1.35	V

■ AC Electrical Characteristics

Table 8 Measurement Conditions

Input pulse voltage	$V_{IH} = 0.8 \times V_{DD}$, $V_{IL} = 0.2 \times V_{DD}$
Input pulse rise / fall time	20 ns
Output determination voltage	$V_{OH} = 0.8 \times V_{DD}$, $V_{OL} = 0.2 \times V_{DD}$
Output load	80 pF + pull-up resistor 10 k Ω

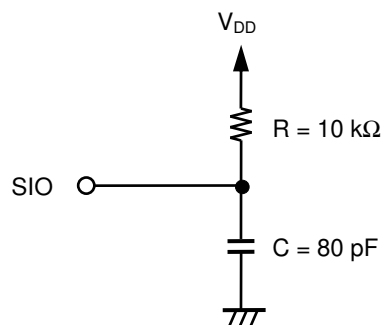

Remark The power supplies of the IC and load have the same electrical potential.

Figure 9 Output Load Circuit

Table 9 AC Electrical Characteristics

($T_a = -40^\circ\text{C}$ to $+85^\circ\text{C}$)

Item	Symbol	$V_{DD}^{*2} \geq 1.3 \text{ V}$			$V_{DD}^{*2} \geq 3.0 \text{ V}$			Unit
		Min.	Typ.	Max.	Min.	Typ.	Max.	
Clock pulse width	t_{SCK}	5	–	250000	1	–	250000	μs
Setup time before CS rise	t_{DS}	1	–	–	0.2	–	–	μs
Hold time after CS rise	t_{CSH}	1	–	–	0.2	–	–	μs
Input data setup time	t_{ISU}	1	–	–	0.2	–	–	μs
Input data hold time	t_{IHO}	1	–	–	0.2	–	–	μs
Output data definition time ^{*1}	t_{ACC}	–	–	3.5	–	–	1	μs
Setup time before CS fall	t_{CSS}	1	–	–	0.2	–	–	μs
Hold time after CS fall	t_{DH}	1	–	–	0.2	–	–	μs
Input rise / fall time	t_R, t_F	–	–	0.1	–	–	0.05	μs

*1. Since the output format of the SIO pin is Nch open-drain output, output data definition time is determined by the values of the load resistance (R_L) and load capacity (C_L) outside the IC. Therefore, use this value only as a reference value.

*2. Regarding the power supply voltage, refer to "■ Recommended Operation Conditions".

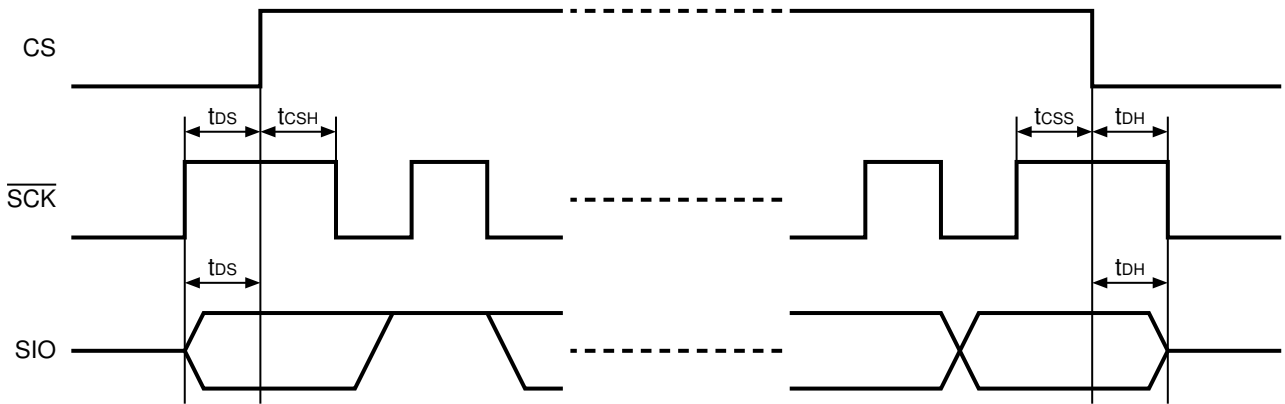

Figure 10 Timing Diagram 1 during 3-wire Communication

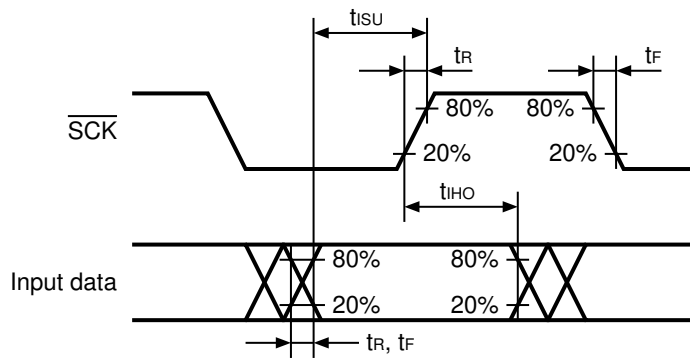

Figure 11 Timing Diagram 2 during 3-wire Communication

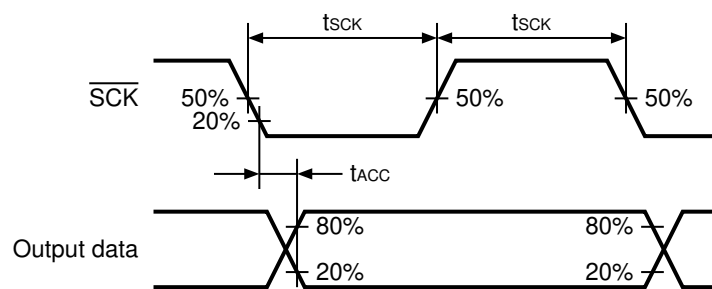

Figure 12 Timing Diagram 3 during 3-wire Communication

■ Configuration of Data Communication

1. Data communication

After setting the CS pin "H", transmit the 4-bit fixed code "0110", after that, transmit a 3-bit command and 1-bit read / write command. Next, data is output or input from B7. Regarding details, refer to "■ Serial Interface".

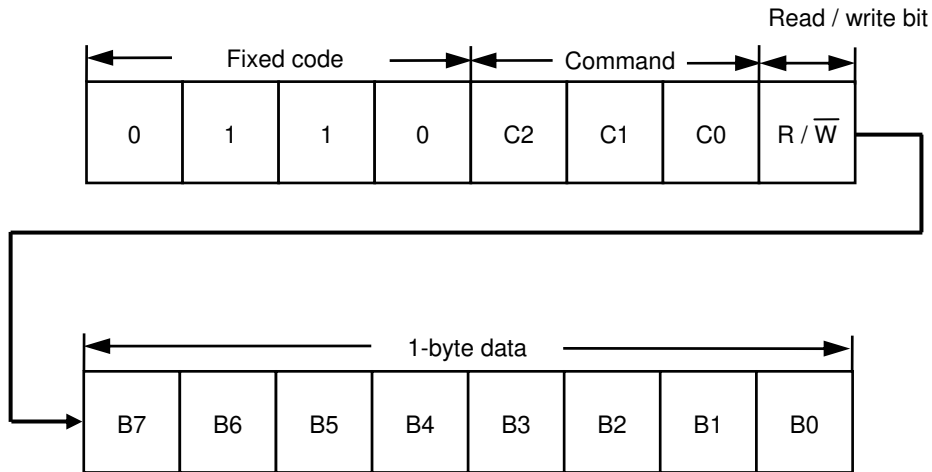

Figure 13 Data Communication

2. Configuration of command

8 types of command are available for the S-35190A. The S-35190A reads / writes the various registers by inputting these fixed codes and commands. The S-35190A does not perform any operation with any codes and commands other than those below. However, in case that the fixed codes or the commands are failed to be recognized in the 1st byte but are successfully recognized in the 2nd and higher bytes, the commands are executed.

Table 10 List of Commands

Fixed Code	Command			Data								
	C2	C1	C0	Description	B7	B6	B5	B4	B3	B2	B1	B0
0110	0	0	0	Status register 1 access	RESET ^{*1}	12 / 24	SC0 ^{*2}	SC1 ^{*2}	INT1 ^{*3}	INT2 ^{*3}	BLD ^{*4}	POC ^{*4}
	0	0	1	Status register 2 access	INT1FE	INT1ME	INT1AE	32KE	SC2 ^{*2}	SC3 ^{*2}	INT2AE	TEST ^{*5}
	0	1	0	Real-time data 1 access (year data to)	Y1 M1 D1 W1 H1 m1 s1	Y2 M2 D2 W2 H2 m2 s2	Y4 M4 D4 W4 H4 m4 s4	Y8 M8 D8 _ ^{*6} _ ^{*6} s8	Y10 M10 D10 _ ^{*6} _ ^{*6} s10	Y20 _ ^{*6} D20 _ ^{*6} _ ^{*6} s20	Y40 _ ^{*6} _ ^{*6} _ ^{*6} AM / PM m40 s40	Y80 _ ^{*6} _ ^{*6} _ ^{*6} _ ^{*6} _ ^{*6} _ ^{*6} _ ^{*6}
	0	1	1	Real-time data 2 access (hour data to)	H1 m1 s1	H2 m2 s2	H4 m4 s4	H8 m8 s8	H10 m10 s10	H20 m20 s20	AM / PM m40 s40	_ ^{*6} _ ^{*6} _ ^{*6}
	1	0	0	INT register 1 access (alarm time 1: week / hour / minute) (INT1AE = 1, INT1ME = 0, INT1FE = 0)	W1 H1 m1	W2 H2 m2	W4 H4 m4	_ ^{*6} H8 m8	_ ^{*6} H10 m10	_ ^{*6} H20 m20	_ ^{*6} AM / PM m40	A1WE A1HE A1mE
				INT register 1 access (output of user-set frequency) (INT1ME = 0, INT1FE = 1)	1 Hz	2 Hz	4 Hz	8 Hz	16 Hz	SC4 ^{*2}	SC5 ^{*2}	SC6 ^{*2}
	1	0	1	INT register 2 access (alarm time 2: week / hour / minute) (INT2AE = 1)	W1 H1 m1	W2 H2 m2	W4 H4 m4	_ ^{*6} H8 m8	_ ^{*6} H10 m10	_ ^{*6} H20 m20	_ ^{*6} AM / PM m40	A2WE A2HE A2mE
	1	1	0	Clock correction register access	V0	V1	V2	V3	V4	V5	V6	V7
	1	1	1	Free register access	F0	F1	F2	F3	F4	F5	F6	F7

- *1. Write-only flag. The S-35190A initializes by writing "1" in this register.
- *2. Scratch bit. This is a register which is available for read / write operations and can be used by users freely.
- *3. Read-only flag. Valid only when using the alarm function. When the alarm time matches, this flag is set to "1", and it is cleared to "0" when reading.
- *4. Read-only flag. "POC" is set to "1" when power is applied. It is cleared to "0" when reading. Regarding "BLD", refer to "■ Low Power Supply Voltage Detection Circuit".
- *5. Test bit for SII. Be sure to set "0" in use.
- *6. No effect when writing. It is "0" when reading.

■ Configuration of Registers

1. Real-time data register

The real-time data register is a 7-byte register that stores the data of year, month, day, day of the week, hour, minute, and second in the BCD code. To write / read real-time data 1 access, transmit / receive the data of year in B7, month, day, day of the week, hour, minute, second in B0, in 7-byte. When you skip the procedure to access the data of year, month, day, day of the week, read / write real-time data 2 accesses. In this case, transmit / receive the data of hour in B7, minute, second in B0, in 3-byte.

The S-35190A transfers a set of data of time to the real-time data register when it recognizes the read command. Therefore, the S-35190A keeps precise time even if time-carry occurs during the read operation of real-time data register.

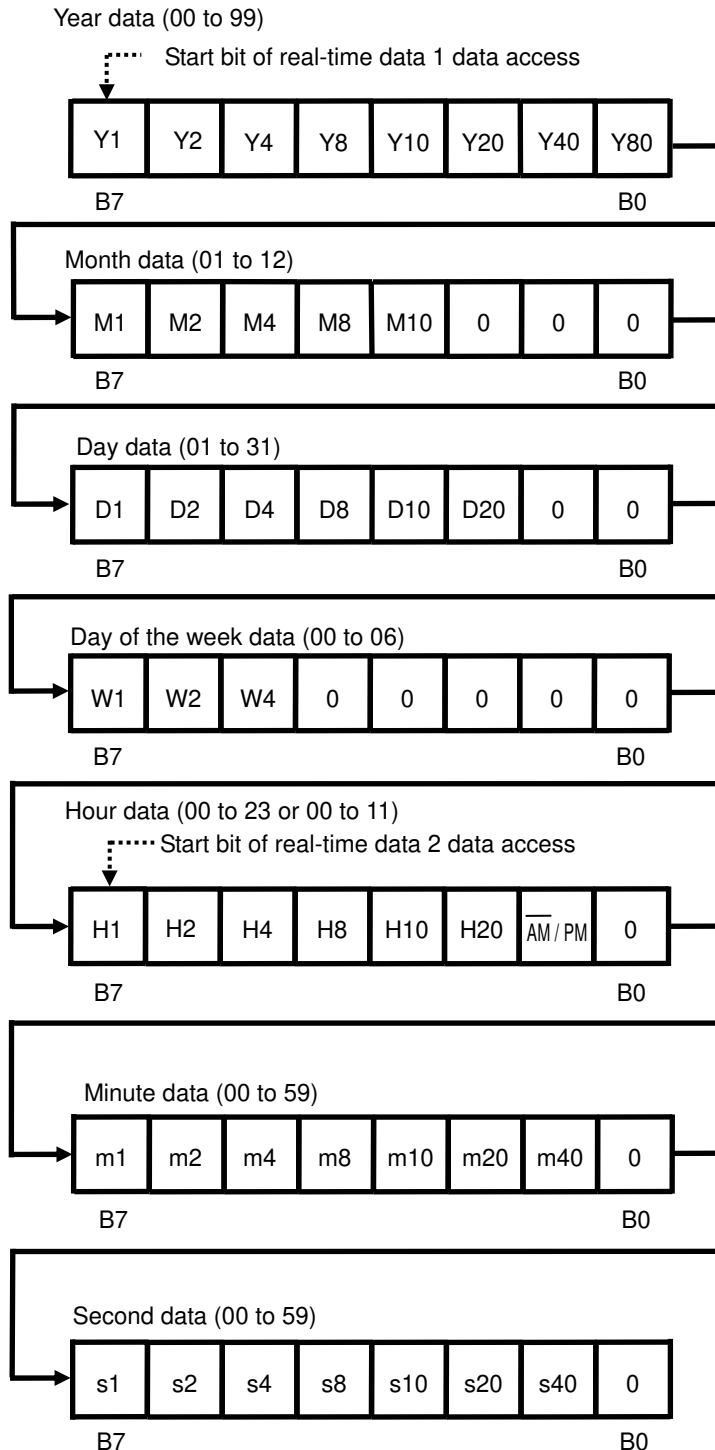

Figure 14 Real-time Data Register

Year data (00 to 99): Y1, Y2, Y4, Y8, Y10, Y20, Y40, Y80

Sets the lower two digits of the Western calendar year (00 to 99) and links together with the auto calendar function until 2099.

Example: 2053 (Y1, Y2, Y4, Y8, Y10, Y20, Y40, Y80) = (1, 1, 0, 0, 1, 0, 1, 0)

Month data (01 to 12): M1, M2, M4, M8, M10

Example: December (M1, M2, M4, M8, M10, 0, 0, 0) = (0, 1, 0, 0, 1, 0, 0, 0)

Day data (01 to 31): D1, D2, D4, D8, D10, D20

The count value is automatically changed by the auto calendar function.

1 to 31: Jan., Mar., May, July, Aug., Oct., Dec., 1 to 30: April, June, Sep., Nov.

1 to 29: Feb. (leap year), 1 to 28: Feb. (non-leap year)

Example: 29 (D1, D2, D4, D8, D10, D20, 0, 0) = (1, 0, 0, 1, 0, 1, 0, 0)

Day of the week data (00 to 06): W1, W2, W4

A septenary up counter. Day of the week is counted in the order of 00, 01, 02, ..., 06, and 00. Set up day of the week and the count value.

Hour data (00 to 23 or 00 to 11): H1, H2, H4, H8, H10, H20, \overline{AM} / PM

In 12-hour mode, write 0; AM, 1; PM in the \overline{AM} / PM bit. In 24-hour mode, users can write either 0 or 1. 0 is read when the hour data is from 00 to 11, and 1 is read when from 12 to 23.

Example (12-hour mode): 11 p.m. (H1, H2, H4, H8, H10, H20, \overline{AM} / PM, 0) = (1, 0, 0, 0, 1, 0, 1, 0)

Example (24-hour mode): 22 (H1, H2, H4, H8, H10, H20, \overline{AM} / PM, 0) = (0, 1, 0, 0, 0, 1, 1, 0)

Minute data (00 to 59): m1, m2, m4, m8, m10, m20, m40

Example: 32 minutes (m1, m2, m4, m8, m10, m20, m40, 0) = (0, 1, 0, 0, 1, 1, 0, 0)

Example: 55 minutes (m1, m2, m4, m8, m10, m20, m40, 0) = (1, 0, 1, 0, 1, 0, 1, 0)

Second data (00 to 59): s1, s2, s4, s8, s10, s20, s40

Example: 19 seconds (s1, s2, s4, s8, s10, s20, s40, 0) = (1, 0, 0, 1, 1, 0, 0, 0)

2. Status register 1

Status register 1 is a 1-byte register that is used to display and set various modes. The bit configuration is shown below.

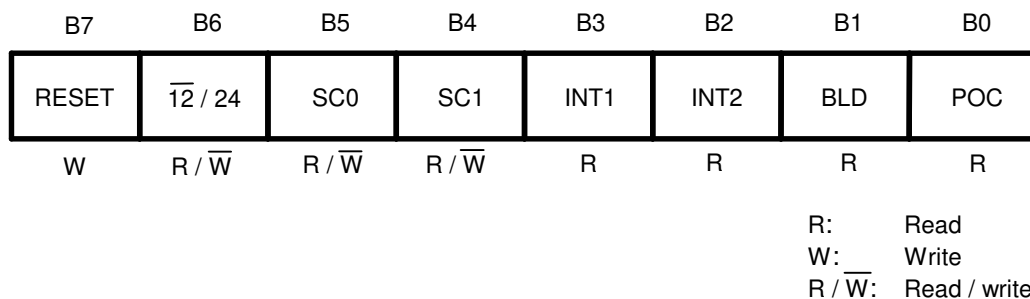

Figure 15 Status Register 1

B0: POC

This flag is used to confirm whether the power is on. The power-on detection circuit operates at power-on and B0 is set to "1". This flag is read-only. Once it is read, it is automatically set to "0". When this flag is "1", be sure to initialize. Regarding the operation after power-on, refer to "■ Power-on Detection Circuit and Register Status".

B1: BLD

This flag is set to "1" when the power supply voltage decreases to the level of detection voltage (V_{DET}) or less. Users can detect a drop in the power supply voltage. This flag is set to "1" once, is not set to "0" again even if the power supply increases to the level of detection voltage (V_{DET}) or more. This flag is read-only. When this flag is "1", be sure to initialize. Regarding the operation of the power supply voltage detection circuit, refer to "■ Low Power Supply Voltage Detection Circuit".

B2: INT2, B3: INT1

This flag indicates the time set by alarm and when the time has reached it. This flag is set to "1" when the time that users set by using the alarm interrupt function has come. The INT1 flag at alarm 1 interrupt mode and the INT2 flag at alarm 2 interrupt mode are set to "1". Set "0" in INT1AE (B5 in the status register 2) or in INT2AE (B1 in the status register 2) after reading "1" in the INT1 flag or in the INT2 flag. This flag is read-only. This flag is read once, is set to "0" automatically.

B4: SC1, B5: SC0

These flags are SRAM type registers, they are 2 bits as a whole, can be freely set by users.

B6: $\overline{12}/24$

This flag is used to set 12-hour or 24-hour mode. Set the flag ahead of write operation of the real-time data register in case of 24-hour mode.

0: 12-hour mode
1: 24-hour mode

B7: RESET

The internal IC is initialized by setting this bit to "1". This bit is write-only. It is always "0" when reading. When applying the power supply voltage to the IC, be sure to write "1" to this bit to initialize the circuit. Regarding each status of data after initialization, refer to "■ Register Status After Initialization".

3. Status register 2

Status register 2 is a 1-byte register that is used to display and set various modes. The bit configuration is shown below.

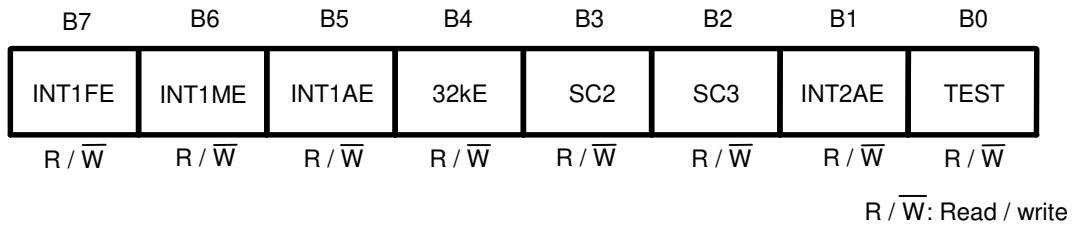

Figure 16 Status Register 2

B0: TEST

This is a test flag for SII. Be sure to set this flag to "0" in use. If this flag is set to "1", be sure to initialize to set "0".

B1: INT2AE

This is an enable bit for alarm 2 interrupt. When this bit is "0", alarm 2 interrupt is disabled. When it is "1", it is enabled. To use alarm 2 interrupt, access the INT register 2 after enabling this flag.

Caution Note that alarm 2 interrupt is output from the \overline{INT} pin regardless of the settings in flags B4 to B7.

B2: SC3, B3: SC2

These are 2-bit SRAM type registers that can be freely set by users.

B4: 32kE, B5: INT1AE, B6: INT1ME, B7: INT1FE

These bits are used to select the output mode for the \overline{INT} pin. **Table 11** shows how to select the mode. To use alarm 1 interrupt, access the INT register 1 after setting the alarm 1 interrupt mode.

Table 11 Output Modes for \overline{INT} Pin

32kE	INT1AE	INT1ME	INT1FE	\overline{INT} Pin Output Mode
0	0	0	0	No interrupt
0	$\overline{*1}$	0	1	Output of user-set frequency
0	$\overline{*1}$	1	0	Per-minute edge interrupt
0	0	1	1	Minute-periodical interrupt 1 (50% duty)
0	1	0	0	Alarm 1 interrupt
0	1	1	1	Minute-periodical interrupt 2
1	$\overline{*1}$	$\overline{*1}$	$\overline{*1}$	32.768 kHz output

*1. Don't care (both of 0 and 1 are acceptable).

4. INT register 1 and INT register 2

The INT register 1 is to set up the output of user-set frequency, or to set up alarm 1 interrupt. The INT register 2 is for setting alarm 2 interrupt. Users are able to switch the output mode by using the status register 2. If selecting to use the output mode for alarm interrupt by status register 2; this register works as the alarm-time data register. In the INT register 1, if selecting the output of user-set frequency by status register 2; this register works as the data register to set the frequency for clock output. From the $\overline{\text{INT}}$ pin, a clock pulse and alarm interrupt are output, according to the or-condition that these two registers have.

4.1 Alarm interrupt

Users can set the alarm time (the data of day of the week, hour, minute) by using the INT register 1 and 2 which are 3-byte data registers. The configuration of register is as well as the data register of day of the week, hour, minute, in the real-time data register; is expressed by the BCD code. Do not set a nonexistent day. Users are necessary to set up the alarm-time data according to the 12 / 24 hour expression that they set by using the status register 1.

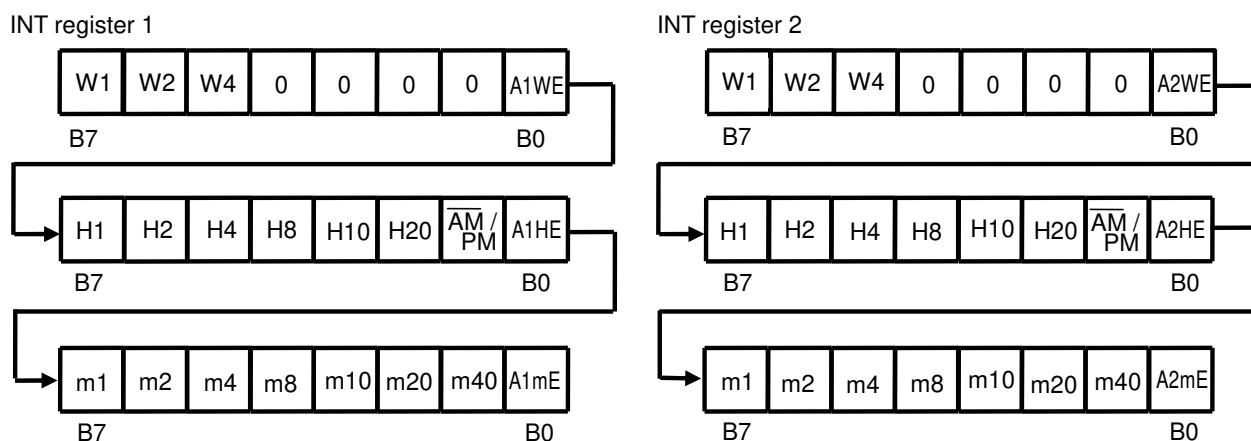

Figure 17 INT Register 1 and INT Register 2 (Alarm-Time Data)

The INT register 1 has A1WE, A1HE, A1mE at B0 in each byte. It is possible to make data valid; the data of day of the week, hour, minute which are in the corresponded byte; by setting these bits to "1". This is as well in A2WE, A2HE, A2mE in the INT register 2.

Setting example: alarm time "7:00 pm" in the INT register 1

(1) 12-hour mode (status register 1 B6 = 0)

set up 7:00 PM

Data written to INT register 1

Day of the week	$_*$	$_*$	$_*$	$_*$	$_*$	$_*$	$_*$	0	
Hour	1	1	1	0	0	0	1	1	
Minute	0	0	0	0	0	0	0	1	
	B7							B0	

*1. Don't care (both of 0 and 1 are acceptable).

(2) 24-hour mode (status register 1 B6 = 1)

set up 19:00 PM

Data written to INT register 1

Day of the week	$_*$	$_*$	$_*$	$_*$	$_*$	$_*$	$_*$	0	
Hour	1	0	0	1	1	0	1 ^{*2}	1	
Minute	0	0	0	0	0	0	0	1	
	B7							B0	

*1. Don't care (both of 0 and 1 are acceptable).

*2. Set up $\overline{\text{AM}}/\text{PM}$ flag along with the time setting.

4.2 Output of user-set frequency

The INT register 1 is a 1-byte data register to set up the output frequency. Setting each bit B7 to B3 in the register to "1", the frequency which corresponds to the bit is output in the AND-form. SC4 to SC6 is 3-bit SRAM type registers that can be freely set by users.

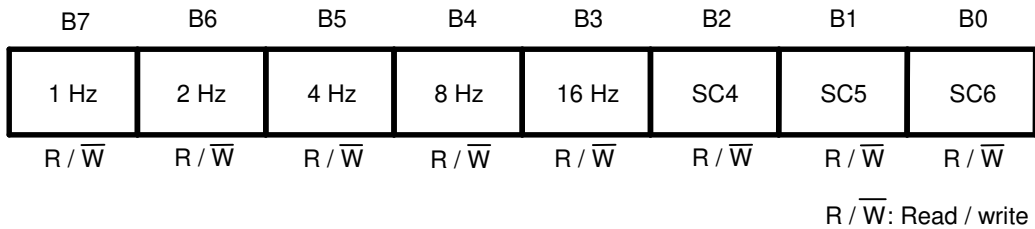

Figure 18 INT Register 1 (Data Register for Output Frequency)

Example: B7 to B3 = 50h

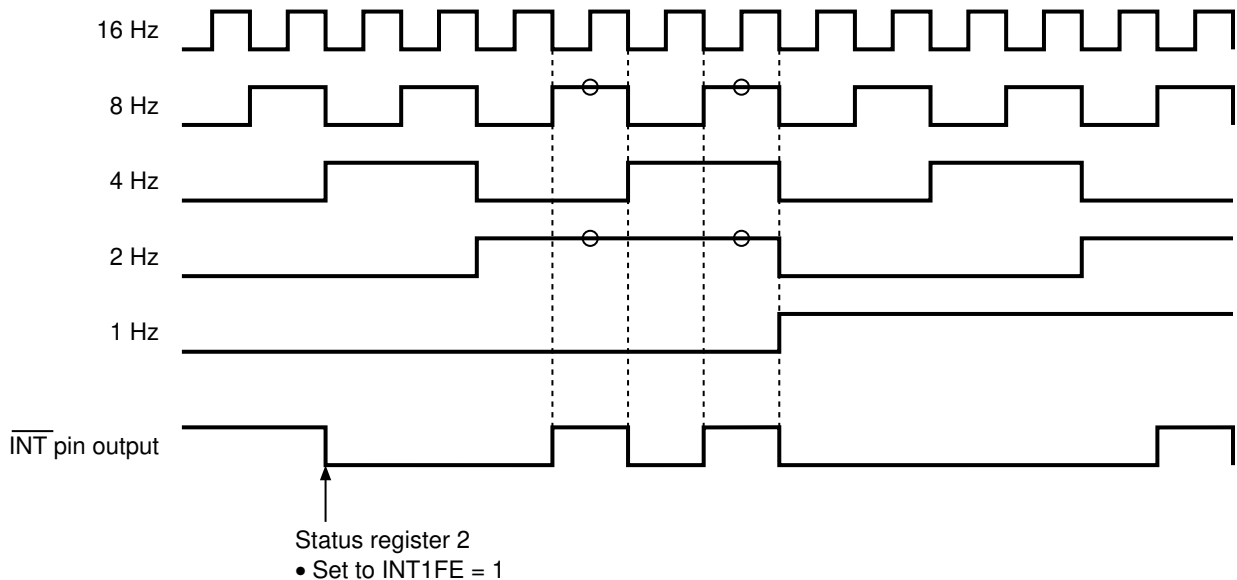

Figure 19 Example of Output from INT Register 1 (Data Register for Output Frequency)

1 Hz clock output is synchronized with second-counter of the S-35190A.

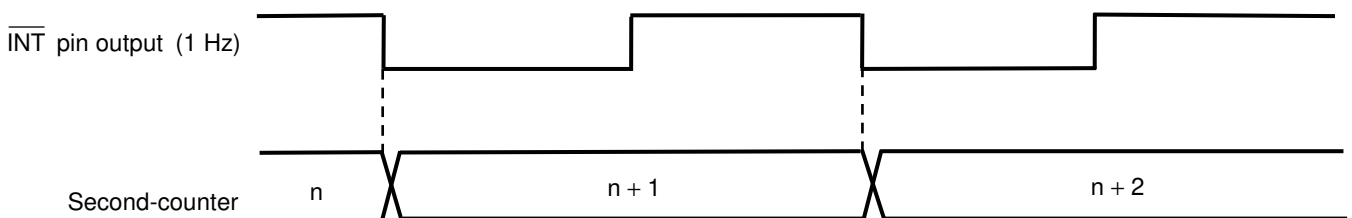

Figure 20 1 Hz Clock Output and Second-counter

5. Clock correction register

The clock correction register is a 1-byte register that is used to correct advance / delay of the clock. When not using this function, set this register to "00h". Regarding the register values, refer to "■ Function to Clock Correction".

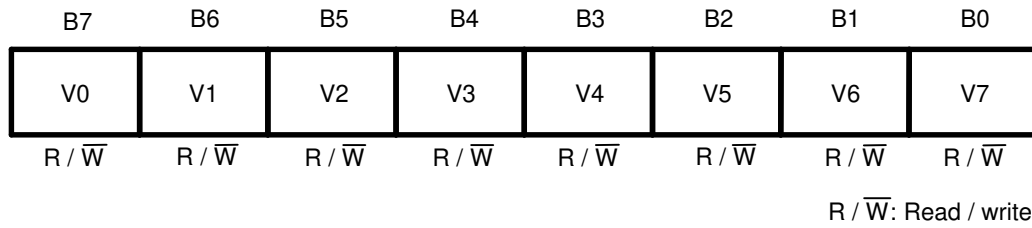

Figure 21 Clock Correction Register

6. Free register

The free register is a 1-byte SRAM type register that can be set freely by users.

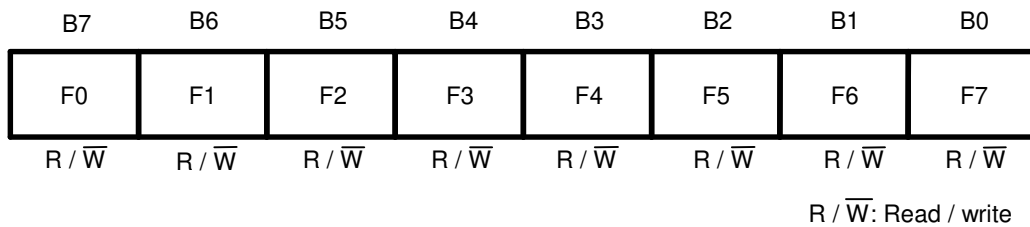

Figure 22 Free Register

■ Power-on Detection Circuit and Register Status

The power-on detection circuit operates by power-on the S-35190A, as a result each register is cleared; each register is set as follows.

Real-time data register:	00 (Y), 01 (M), 01 (D), 0 (day of the week), 00 (H), 00 (M), 00 (S)
Status register 1:	"01h"
Status register 2:	"80h"
INT register 1:	"80h"
INT register 2:	"00h"
Clock correction register:	"00h"
Free register:	"00h"

"1" is set in the POC flag (B0 in the status register 1) to indicate that power has been applied. To correct the oscillation frequency, the status register 2 goes in the mode the output of user-set frequency, so that 1 Hz clock pulse is output from the $\overline{\text{INT}}$ pin. When "1" is set in the POC flag, be sure to initialize. The POC flag is set to "0" due to initialization so that the output of user-set frequency mode is cleared. (Refer to "■ Register Status After Initialization".)

For the regular operation of power-on detection circuit, as seen in **Figure 23**, the period to power-up the S-35190A is that the voltage reaches 1.3 V within 10 ms after setting the IC's power supply voltage at 0 V. When the power-on detection circuit is not working normally is; the POC flag (B0 in the status register) is not in "1", or 1 Hz is not output from the INT pin. In this case, power-on the S-35190A once again because the internal data may be in the indefinite status.

Moreover, regarding the processing right after power-on, refer to "■ Flowchart of Initialization and Example of Real-time Data Set-up".

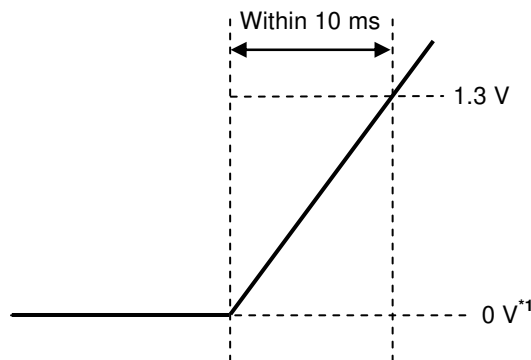

*1. 0 V indicates that there are no potential differences between the VDD pin and VSS pin of the S-35190A.

Figure 23 How to Raise the Power Supply Voltage

■ Register Status After Initialization

The status of each register after initialization is as follows.

Real-time data register: 00 (Y), 01 (M), 01 (D), 0 (day of the week), 00 (H), 00 (M), 00 (S)
 Status register 1: "0 B6 B5 B4 0 0 0 0 b"
 (In B6, B5, B4, the data of B6, B5, B6 in the status register 1 at initialization is set. Refer to **Figure 24**.)
 Status register 2: "00h"
 INT register 1: "00h"
 INT register 2: "00h"
 Clock correction register: "00h"
 Free register: "00h"

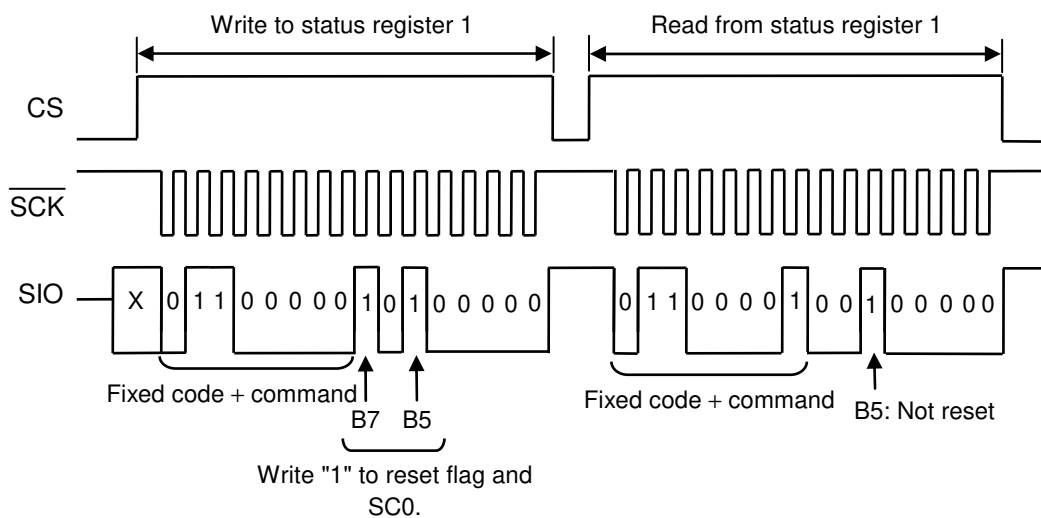

Figure 24 Status Register 1 Data at Initialization

■ Low Power Supply Voltage Detection Circuit

The S-35190A has a low power supply voltage detection circuit, so that users can monitor drops in the power supply voltage by reading the BLD flag (B1 in the status register 1). There is a hysteresis width of approx. 0.15 V (typ.) between detection voltage and release voltage (refer to "■ Characteristics (Typical Data)"). The low power supply voltage detection circuit does the sampling operation only once in one sec for 15.6 ms.

If the power supply voltage decreases to the level of detection voltage (V_{DET}) or less, "1" is set to the BLD flag so that sampling operation stops. Once "1" is detected in the BLD flag, no sampling operation is performed even if the power supply voltage increases to the level of release voltage or more, and "1" is held in the BLD flag.

If the BLD flag is "1" even after the power supply voltage is recovered, the internal circuit may be in the indefinite status. In this case, be sure to initialize the circuit. After reading the BLD flag, the sampling operation is restarted. Without initializing, if the next BLD flag reading is done after sampling, the BLD flag gets reset to "0". In this case, be sure to initialize although the BLD flag is in "0" because the internal circuit may be in the indefinite status.

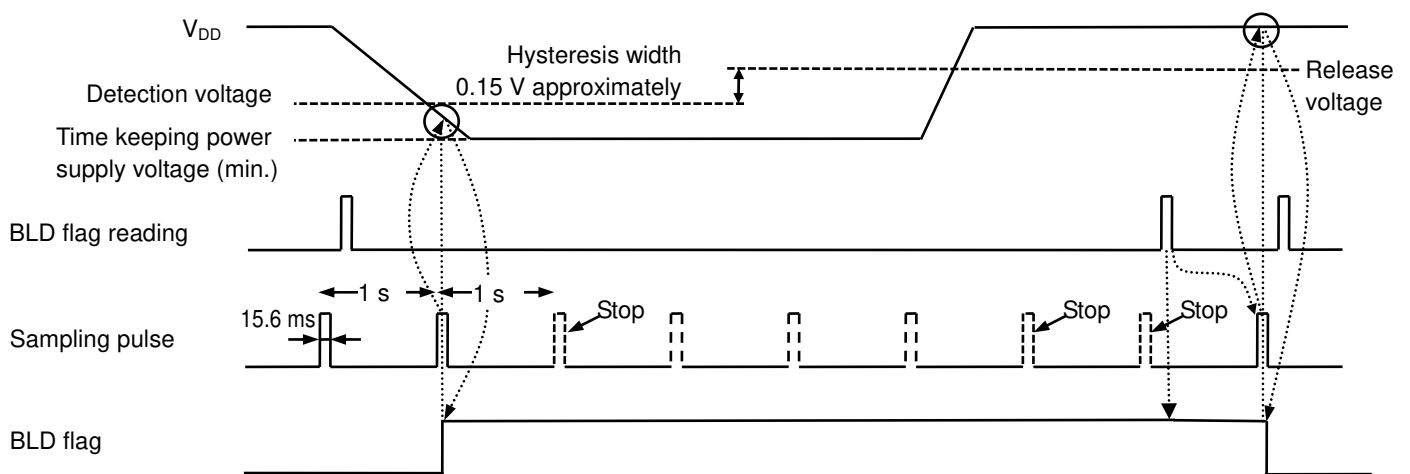

Figure 25 Timing of Low Power Supply Voltage Detection Circuit

■ Circuits Power-on and Low Power Supply Voltage Detection

Figure 26 shows the changes of the POC flag and BLD flag due to V_{DD} fluctuation.

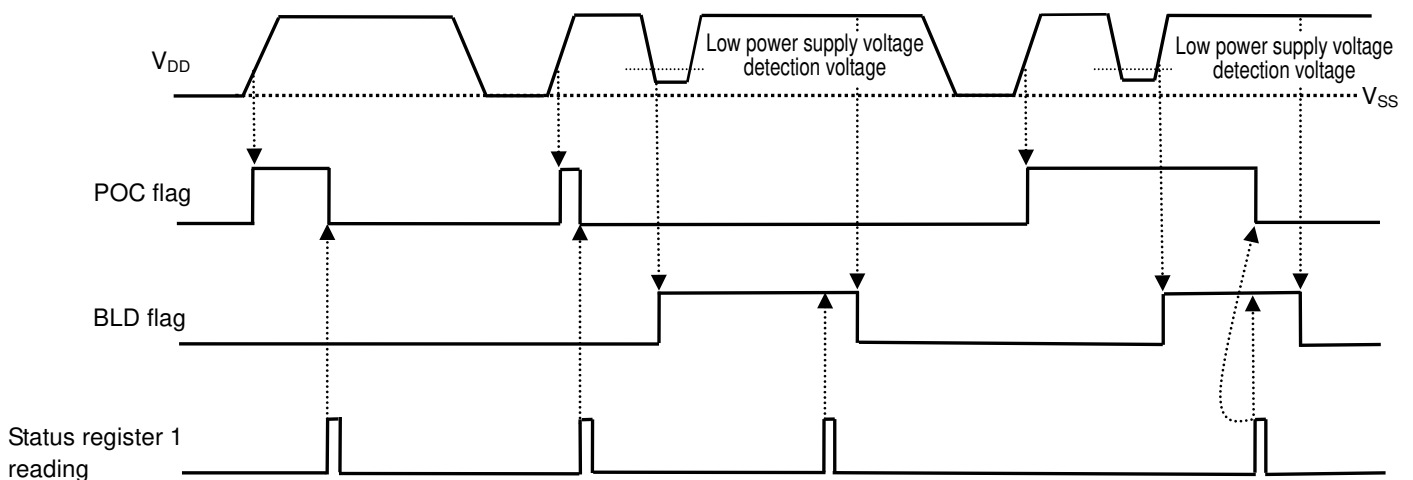

Figure 26 POC Flag and BLD Flag

■ Correction of Nonexistent Data and End-of-Month

When users write the real-time data, the S-35190A checks it. In case that the data is invalid, the S-35190A does the following procedures.

1. Processing of nonexistent data

Table 12 Processing of Nonexistent Data

Register	Normal Data	Nonexistent Data	Result	
Year data	00 to 99	XA to XF, AX to FX	00	
Month data	01 to 12	00, 13 to 19, XA to XF	01	
Day data	01 to 31	00, 32 to 39, XA to XF	01	
Day of the week data	0 to 6	7	0	
Hour data ^{*1}	24-hour	0 to 23	24 to 29, 3X, XA to XF	00
	12-hour	0 to 11	12 to 20, XA to XF	00
Minute data	00 to 59	60 to 79, XA to XF	00	
Second data ^{*2}	00 to 59	60 to 79, XA to XF	00	

*1. In 12-hour mode, write the $\overline{\text{AM}} / \text{PM}$ flag (B1 in hour data in the real-time data register).

In 24-hour expression, the $\overline{\text{AM}} / \text{PM}$ flag in the real-time data register is omitted. However in the flag of reading, users are able to read 0; 0 to 11, 1; 12 to 23.

*2. Processing of nonexistent data, regarding second data, is done by a carry pulse which is generated in 1 second, after writing. At this point the carry pulse is sent to the minute-counter.

2. Correction of end-of-month

A nonexistent day, such as February 30 and April 31, is set to the first day of the next month.

■ $\overline{\text{INT}}$ Pin Output Mode

These are selectable for the $\overline{\text{INT}}$ pin output mode;

Alarm 1 interrupt, alarm 2 interrupt, the output of user-set frequency, per-minute edge interrupt output, minute-periodical interrupt output 1 and 2, 32.768 kHz output.

In alarm 1 interrupt / output of frequency; set data in the INT register 1. In alarm 2 interrupt, set data in the INT register 2. To switch the output mode, use the status register 2. Refer to "3. Status register 2" in "■ Configuration of Registers".

When switching the output mode, be careful of the output status of the pin. Especially, when using alarm interrupt / output of frequency, switch the output mode after setting "00h" in the INT register 1 or 2. Alarm 2 interrupt is dependent from other modes. Regardless of other settings of mode if alarm 2 interrupt was generated, be careful that "L" is output from the $\overline{\text{INT}}$ pin. In 32.768 kHz output / per-minute edge interrupt output / minute-periodical interrupt output, it is unnecessary to set data in the INT register 1 or 2 for users.

Refer to the followings regarding each operation of output modes.

1. Alarm interrupt output

Alarm interrupt output is the function to output "L" from the $\overline{\text{INT}}$ pin, at the alarm time which is set by user has come. If setting the pin output to "H", turn off the alarm function by setting "0" in INT1AE / INT2AE in the status register 2.

To set the alarm time, set the data of day of the week, hour, minute in the INT register 1 or 2, set the data of year, month, day in the INT register 1 or 2. Refer to "4. INT register 1 and INT register 2" in "■ Configuration of Register".

1.1 Alarm setting of "W (day of the week), H (hour), m (minute)"

Status register 2 setting

- Alarm 1 interrupt
32kE = 0, INT1ME = INT1FE = 0
- Alarm 2 interrupt
None

INT register x alarm enable flag

- AxHE = AxmE = AxWE = "1"

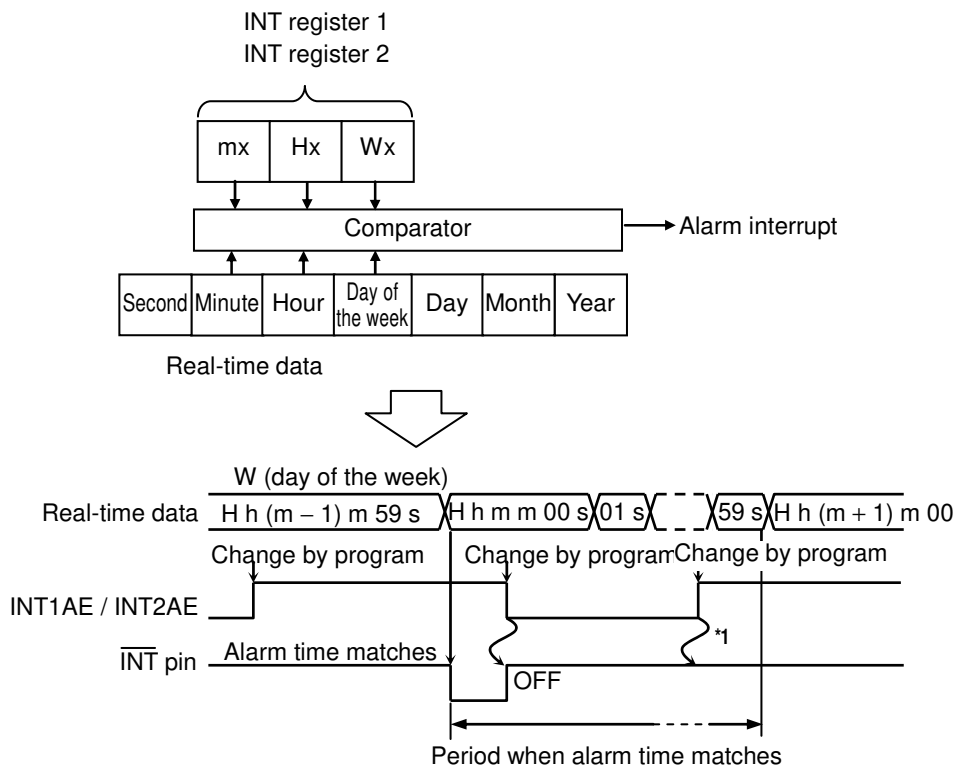

*1. If users clear INT1AE / INT2AE once; "L" is not output from the $\overline{\text{INT}}$ pin by setting INT1AE / INT2AE enable again, within a period when the alarm time matches real-time data.

Figure 27 Alarm Interrupt Output Timing

1.2 Alarm setting of "H (hour)"

Status register 2 setting

- Alarm 1 interrupt
32kE = 0, INT1ME = INT1FE = 0
- Alarm 2 interrupt
None

INT register x alarm enable flag

- AxWE = AxmE = "0", AxHE = "1"

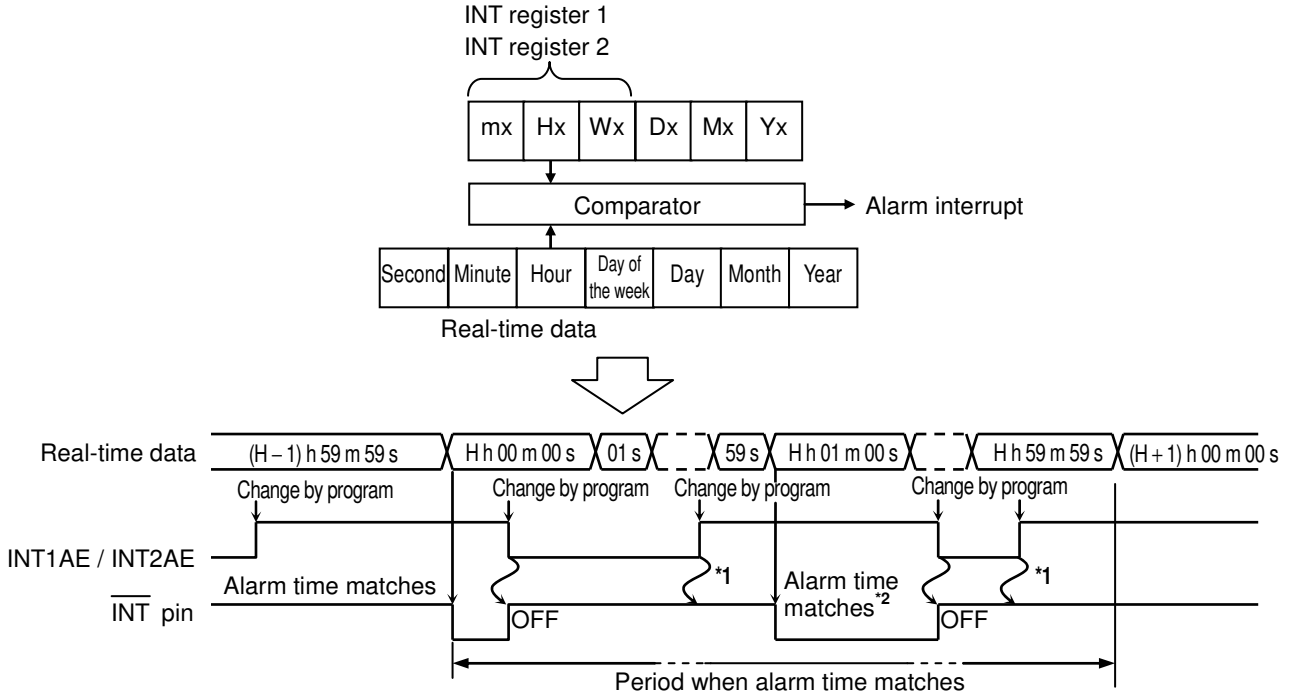

- *1. If users clear INT1AE / INT2AE once; "L" is not output from the $\overline{\text{INT}}$ pin by setting INT1AE / INT2AE enable again, within a period when the alarm time matches real-time data.
- *2. If turning the alarm output on by changing the program, within the period when the alarm time matches real-time data, "L" is output again from the $\overline{\text{INT}}$ pin when the minute is counted up.

Figure 28 Alarm Interrupt Output Timing

2. Output of user-set frequency

The output of user-set frequency is the function to output the frequency which is selected by using data, from the INT pin, in the AND-form. Set up the data of frequency in the INT register 1.

Refer to "4. INT register 1 and INT register 2" in "■ Configuration of Register".

Status register 2 setting

32kE = 0, INT1AE = Don't care (0 or 1), INT1ME = 0

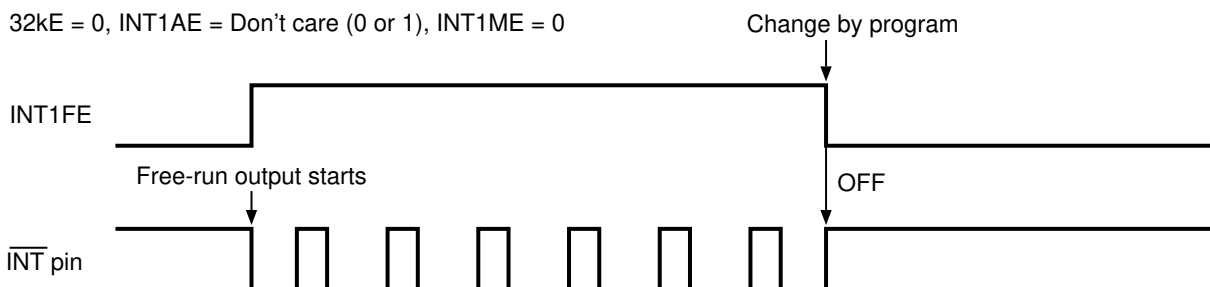

Figure 29 Output Timing of User-set Frequency