



Chipsmall Limited consists of a professional team with an average of over 10 year of expertise in the distribution of electronic components. Based in Hongkong, we have already established firm and mutual-benefit business relationships with customers from,Europe,America and south Asia,supplying obsolete and hard-to-find components to meet their specific needs.

With the principle of “Quality Parts,Customers Priority,Honest Operation,and Considerate Service”,our business mainly focus on the distribution of electronic components. Line cards we deal with include Microchip,ALPS,ROHM,Xilinx,Pulse,ON,Everlight and Freescale. Main products comprise IC,Modules,Potentiometer,IC Socket,Relay,Connector.Our parts cover such applications as commercial,industrial, and automotives areas.

We are looking forward to setting up business relationship with you and hope to provide you with the best service and solution. Let us make a better world for our industry!



Contact us

Tel: +86-755-8981 8866 Fax: +86-755-8427 6832

Email & Skype: info@chipsmall.com Web: www.chipsmall.com

Address: A1208, Overseas Decoration Building, #122 Zhenhua RD., Futian, Shenzhen, China





S-89530A/89531A Series

MINI ANALOG SERIES 0.7 μ A Rail-to-Rail CMOS COMPARATOR

www.sii-ic.com

© Seiko Instruments Inc., 2001-2010

Rev.4.0_00

The mini analog series is a group of ICs that incorporate a general-purpose analog circuit in an ultra-small packages.

The S-89530A/89531A Series are CMOS type comparators that feature Rail-to-Rail ^{*1} I/O and can be driven at a lower voltage and lower current consumption than existing comparators, making the S-89530A/89531A for use in battery-powered compact portable devices.

*1. Rail-to-Rail is a registered trademark of Motorola Inc.

■ Features

- Can be driven lower voltage than existing general-purpose comparators: $V_{DD} = 0.9 \text{ V to } 5.5 \text{ V}$
- Low current consumption: $I_{DD} = 0.7 \mu\text{A (Typ.)}$
- Rail-to-Rail wide input and output voltage range: $V_{CMR} = V_{SS} \text{ to } V_{DD}$
- Low input offset voltage: 5.0 mV max.
- Lead-free, halogen-free ^{*1}

*1. Refer to “■ Product Code List” for details.

■ Applications

- Cellular phones
- PDAs
- Notebook PCs
- Digital cameras
- Digital video cameras

■ Package

Package Name	Drawing Code		
	Package	Tape	Reel
SC-88A	NP005-B-P-SD	NP005-B-C-SD	NP005-B-R-SD

■ Product Code List

Table 1

Input Offset Voltage	Product Name (Single)
$V_{IO} = 10 \text{ mV max.}$	S-89530ACNC-HCBTFz
$V_{IO} = 5 \text{ mV max.}$	S-89531ACNC-HCCTFz

Remark z: G or S

Pin Configuration

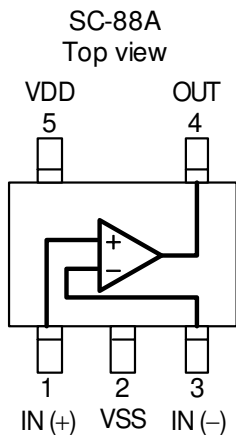

Figure 1

Table 2

Pin No.	Symbol	Description	Internal Equivalent Circuit
1	IN(+)	Non-inverted input pin	Figure 3
2	VSS	GND pin	—
3	IN(-)	Inverted input pin	Figure 3
4	OUT	Output pin	Figure 2
5	VDD	Positive power supply pin	Figure 4

Internal Equivalent Circuits

(1) Output pin

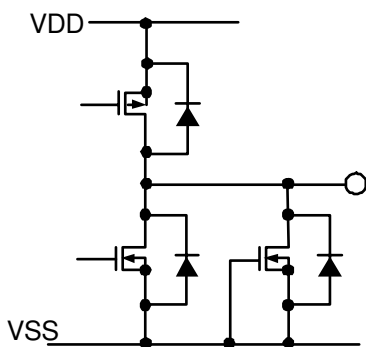

Figure 2

(2) Input pin

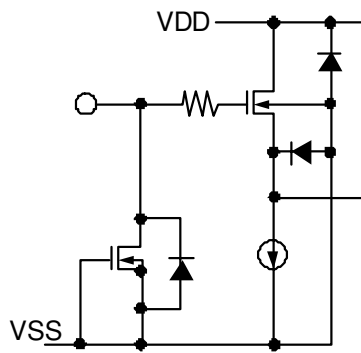

Figure 3

(3) VDD pin

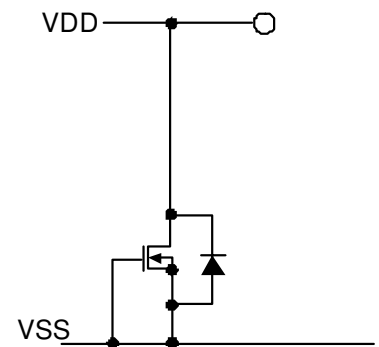

Figure 4

■ **Absolute Maximum Ratings**

Table 3

(Ta = 25°C unless otherwise specified)

Parameter	Symbol	Ratings	Unit
Power supply voltage	V_{DD}	$V_{SS}-0.3$ to $V_{SS}+7.0$	V
Input voltage	V_{IN}	$V_{SS}-0.3$ to $V_{SS}+7.0$ (7.0 max.)	V
Output voltage	V_{OUT}	$V_{SS}-0.3$ to $V_{DD}+0.3$ (7.0 max.)	V
Differential input voltage	V_{IND}	± 5.5	V
Power dissipation	P_D	200 (When not mounted on board)	mW
		350^{*1}	mW
Operating temperature	T_{opr}	-40 to +85	°C
Storage temperature	T_{sto}	-55 to +125	°C

*1. When mounted on board

[Mounted board]

- (1) Board size : 114.3 mm × 76.2 mm × t1.6 mm
- (2) Board name : JEDEC STANDARD51-7

Caution The absolute maximum ratings are rated values exceeding which the product could suffer physical damage. These values must therefore not be exceeded under any conditions.

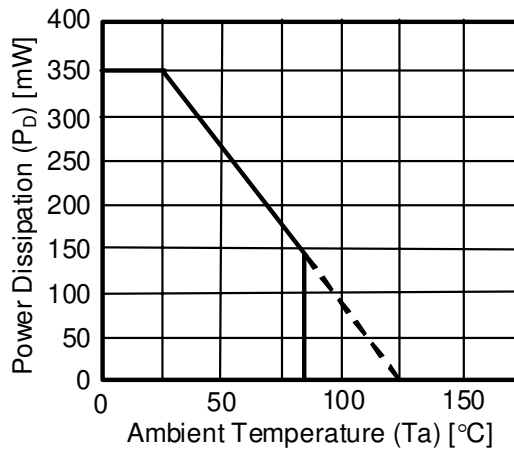

Figure 5 Power Dissipation of Package (When Mounted on Board)

■ **Recommended Operating Voltage Range**

Table 4

Parameter	Symbol	Range	Unit
Operating power supply voltage range	V_{DD}	0.9 to 5.5	V

■ **Electrical Characteristics**

The S-89530ACNC and S-89531ACNC only differ in the input offset voltage. All other specifications are the same.

1. $V_{DD} = 3.0$ V

Table 5

DC Characteristics ($V_{DD} = 3.0$ V)

($T_a = 25^\circ\text{C}$ unless otherwise specified)

Parameter	Symbol	Conditions	Min.	Typ.	Max.	Unit	Measurement circuit
Supply current	I_{DDH}	$V_{IN1} = V_{SS}, V_{IN2} = V_{DD}, R_L = \infty$	—	0.7	1.4	μA	Figure 11
	I_{DDL}	$V_{IN1} = V_{DD}, V_{IN2} = V_{SS}, R_L = \infty$	—	0.25	0.5		
Input offset voltage	V_{IO}	S-89530A: $V_{CMR} = 1.5$ V	-10	± 5	+10	mV	Figure 7
		S-89531A: $V_{CMR} = 1.5$ V	-5	± 3	+5		
Input offset current	I_{IO}	—	—	1	—	μA	—
Input bias current	I_{BIAS}	—	—	1	—		
Common-mode input voltage range	V_{CMR}	—	0	—	3.0	V	Figure 8
Voltage gain (open loop)	A_{VOL}	$V_{CMR} = 1.5$ V, $R_L = 1$ M Ω	—	86	—	dB	—
Maximum output swing voltage	V_{OH}	$R_L = 1$ M Ω	2.98	—	—	V	Figure 9
	V_{OL}	$R_L = 1$ M Ω	—	—	0.02		Figure 10
Common-mode input signal rejection ratio	CMRR	$V_{SS} \leq V_{CMR} \leq V_{DD}$	45	65	—	dB	Figure 8
Power supply voltage rejection ratio	PSRR	$V_{DD} = 0.9$ V to 5.5 V	66	75	—	dB	Figure 6
Source current*1	I_{SOURCE}	$V_{OUT} = V_{DD} - 0.1$ V	380	500	—	μA	Figure 12
		$V_{OUT} = 0$ V	4000	5500	—		
Sink current	I_{SINK}	$V_{OUT} = 0.1$ V	400	550	—	μA	Figure 13
		$V_{OUT} = V_{DD}$	4800	6000	—		

*1. Be sure to use the product with a source current of no more than 7 mA.

Table 6

AC Characteristics ($V_{DD} = 3.0$ V)

($T_a = 25^\circ\text{C}$ unless otherwise specified)

Parameter	Symbol	Conditions	Min.	Typ.	Max.	Unit
Rise propagation delay time	t_{PLH}	Overdrive = 100 mV $C_L = 15$ pF (Refer to Figure 14)	—	110	—	μs
Fall propagation delay time	t_{PHL}		—	280	—	
Rise response time	t_{TLH}		—	10	—	
Fall response time	t_{THL}		—	30	—	

2. $V_{DD} = 1.8$ V

Table 7

DC Characteristics ($V_{DD} = 1.8$ V) ($T_a = 25^\circ\text{C}$ unless otherwise specified)

Parameter	Symbol	Conditions	Min.	Typ.	Max.	Unit	Measurement circuit
Supply current	I_{DDH}	$V_{IN1} = V_{SS}, V_{IN2} = V_{DD}, R_L = \infty$	—	0.7	1.4	μA	Figure 11
	I_{DDL}	$V_{IN1} = V_{DD}, V_{IN2} = V_{SS}, R_L = \infty$	—	0.25	0.5		
Input offset voltage	V_{IO}	S-89530A: $V_{CMR} = 0.9$ V	-10	± 5	+10	mV	Figure 7
		S-89531A: $V_{CMR} = 0.9$ V	-5	± 3	+5		
Input offset current	I_{IO}	—	—	1	—	pA	—
Input bias current	I_{BIAS}	—	—	1	—		
Common-mode input voltage range	V_{CMR}	—	0	—	1.8	V	Figure 8
Voltage gain (open loop)	A_{VOL}	$V_{CMR} = 0.9$ V, $R_L = 1$ M Ω	—	80	—	dB	—
Maximum output swing voltage	V_{OH}	$R_L = 1$ M Ω	1.78	—	—	V	Figure 9
	V_{OL}	$R_L = 1$ M Ω	—	—	0.02		Figure 10
Common-mode input signal rejection ratio	CMRR	$V_{SS} \leq V_{CMR} \leq V_{DD}$	35	55	—	dB	Figure 8
		$V_{SS} \leq V_{CMR} \leq V_{DD} - 0.2$ V	45	60	—		
Power supply voltage rejection ratio	PSRR	$V_{DD} = 0.9$ V to 5.5 V	66	75	—	dB	Figure 6
Source current	I_{SOURCE}	$V_{OUT} = V_{DD} - 0.1$ V	200	250	—	μA	Figure 12
		$V_{OUT} = 0$ V	1000	1500	—		
Sink current	I_{SINK}	$V_{OUT} = 0.1$ V	220	300	—	μA	Figure 13
		$V_{OUT} = V_{DD}$	1200	1800	—		

Table 8

AC Characteristics ($V_{DD} = 1.8$ V) ($T_a = 25^\circ\text{C}$ unless otherwise specified)

Parameter	Symbol	Conditions	Min.	Typ.	Max.	Unit
Rise propagation delay time	t_{PLH}	Overdrive = 100 mV $C_L = 15$ pF (Refer to Figure 14)	—	90	—	μs
Fall propagation delay time	t_{PHL}		—	160	—	
Rise response time	t_{TLH}		—	8	—	
Fall response time	t_{THL}		—	25	—	

3. $V_{DD} = 0.9$ V

Table 9

DC Characteristics ($V_{DD} = 0.9$ V)

($T_a = 25^\circ\text{C}$ unless otherwise specified)

Parameter	Symbol	Conditions	Min.	Typ.	Max.	Unit	Measurement circuit
Supply current	I_{DDH}	$V_{IN1} = V_{SS}, V_{IN2} = V_{DD}, R_L = \infty$	—	0.7	1.3	μA	Figure 11
	I_{DDL}	$V_{IN1} = V_{DD}, V_{IN2} = V_{SS}, R_L = \infty$	—	0.25	0.5		
Input offset voltage	V_{IO}	S-89530A: $V_{CMR} = 0.45$ V	-10	± 5	+10	mV	Figure 7
		S-89531A: $V_{CMR} = 0.45$ V	-5	± 3	+5		
Input offset current	I_{IO}	—	—	1	—	pA	—
Input bias current	I_{BIAS}	—	—	1	—		
Common-mode input voltage range	V_{CMR}	—	0	—	0.9	V	Figure 8
Voltage gain (open loop)	A_{VOL}	$V_{CMR} = 0.45$ V, $R_L = 1$ M Ω	—	74	—	dB	—
Maximum output swing voltage	V_{OH}	$R_L = 1$ M Ω	0.88	—	—	V	Figure 9
	V_{OL}	$R_L = 1$ M Ω	—	—	0.02		Figure 10
Common-mode input signal rejection ratio	CMRR	$V_{SS} \leq V_{CMR} \leq V_{DD}$	25	50	—	dB	Figure 8
		$V_{SS} \leq V_{CMR} \leq V_{DD} - 0.3$ V	40	60	—		
Power supply voltage rejection ratio	PSRR	$V_{DD} = 0.9$ V to 5.5 V	66	75	—	dB	Figure 6
Source current	I_{SOURCE}	$V_{OUT} = V_{DD} - 0.1$ V	10	45	—	μA	Figure 12
		$V_{OUT} = 0$ V	12	70	—		
Sink current	I_{SINK}	$V_{OUT} = 0.1$ V	10	65	—	μA	Figure 13
		$V_{OUT} = V_{DD}$	12	120	—		

Table 10

AC Characteristics ($V_{DD} = 0.9$ V)

($T_a = 25^\circ\text{C}$ unless otherwise specified)

Parameter	Symbol	Conditions	Min.	Typ.	Max.	Unit
Rise propagation delay time	t_{PLH}	Overdrive = 100 mV $C_L = 15$ pF (Refer to Figure 14)	—	65	—	μs
Fall propagation delay time	t_{PHL}		—	65	—	μs
Rise response time	t_{TLH}		—	5	—	μs
Fall response time	t_{THL}		—	20	—	μs

■ Measurement Circuits

1. Power supply voltage rejection ratio

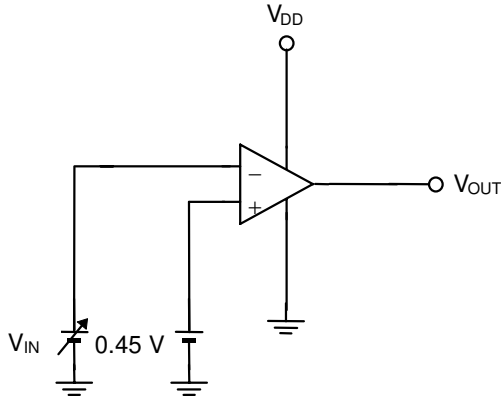

Figure 6

- The power supply voltage rejection ratio (PSRR) is calculated by the following expression, with the value of V_{IO} measured at each V_{DD} .

Measurement conditions:

When $V_{DD} = 0.9$ V: $V_{DD} = V_{DD1}$, $V_{IO} = V_{IO1}$

When $V_{DD} = 5.5$ V: $V_{DD} = V_{DD2}$, $V_{IO} = V_{IO2}$

$$PSRR = 20 \log \left(\left| \frac{V_{DD1} - V_{DD2}}{V_{IO1} - V_{IO2}} \right| \right)$$

2. Input offset voltage

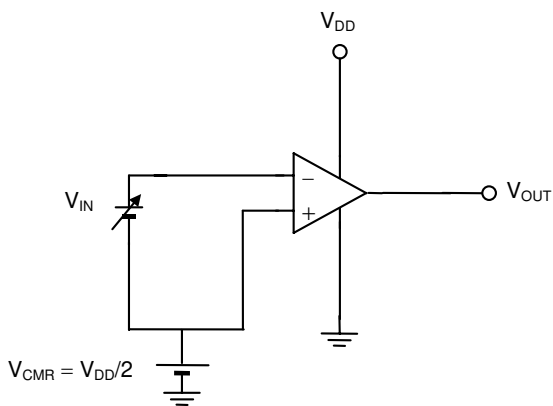

Figure 7

- Input offset voltage (V_{IO})
The input offset voltage (V_{IO}) is defined as V_{IN} at which V_{OUT} changes by changing V_{IN} .

3. Common-mode input signal rejection rate, common-mode input voltage range

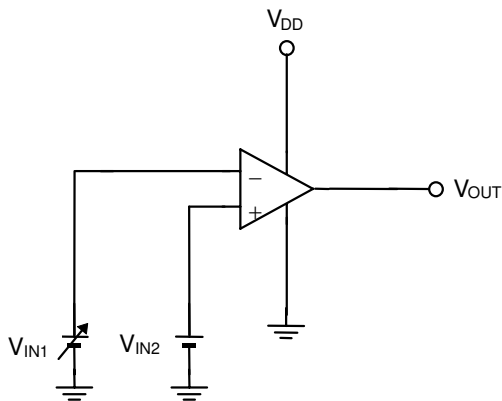

Figure 8

- Common-mode input signal rejection ratio (CMRR)
The common-mode input signal rejection ratio, CMRR, can be calculated by the following expression, with the offset voltage (V_{IO}) defined as V_{IN1} minus V_{IN2} at which V_{OUT} is changed by changing V_{IN1} .

Measurement conditions:

When $V_{IN2} = V_{CMR}(\text{max.})$: $V_{IO} = V_{IO1}$

When $V_{IN2} = V_{CMR}(\text{min.})$: $V_{IO} = V_{IO2}$

$$CMRR = 20 \log \left(\frac{V_{CMR}(\text{max.}) - V_{CMR}(\text{min.})}{V_{IO1} - V_{IO2}} \right)$$

- Common-mode input voltage range (V_{CMR})
The common-mode input voltage range is the range of V_{IN2} within which V_{OUT} satisfies the common mode input signal rejection ratio specification.

4. Maximum output swing voltage

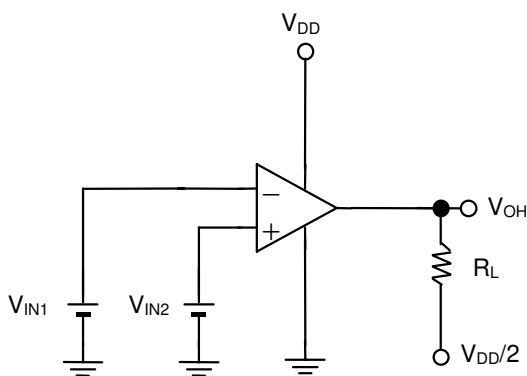

Figure 9

- Maximum output swing voltage (V_{OH})
Measurement conditions: $V_{IN1} = \frac{V_{DD}}{2} - 0.1 \text{ V}$
 $V_{IN2} = \frac{V_{DD}}{2} + 0.1 \text{ V}$
 $R_L = 1 \text{ M}\Omega$

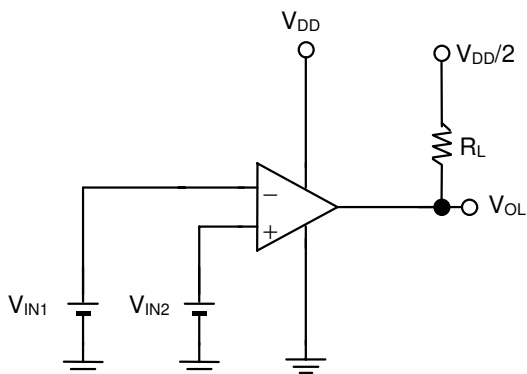

Figure 10

- Maximum output swing voltage (V_{OL})
Measurement conditions: $V_{IN1} = \frac{V_{DD}}{2} + 0.1 \text{ V}$
 $V_{IN2} = \frac{V_{DD}}{2} - 0.1 \text{ V}$
 $R_L = 1 \text{ M}\Omega$

5. Supply current

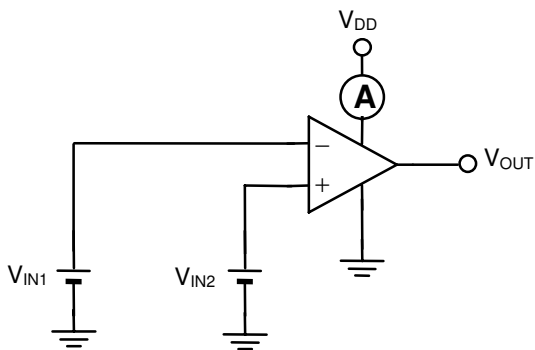

Figure 11

- Supply current (I_{DDH})
Measurement conditions: $V_{IN1} = V_{SS}$
 $V_{IN2} = V_{DD}$
- Supply current (I_{DDL})
Measurement conditions: $V_{IN1} = V_{DD}$
 $V_{IN2} = V_{SS}$

6. Source current

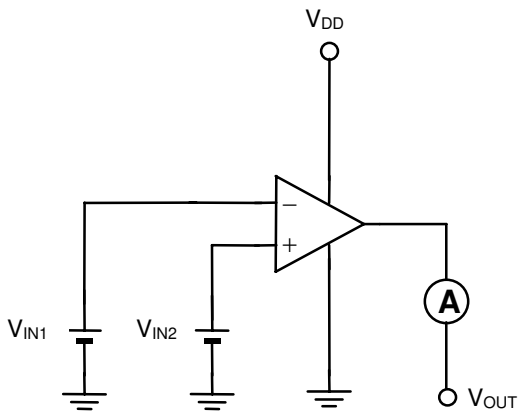

Figure 12

- Source current (I_{SOURCE})
Measurement conditions: $V_{IN1} = \frac{V_{DD}}{2} - 0.1\text{ V}$
 $V_{IN2} = \frac{V_{DD}}{2} + 0.1\text{ V}$
 $V_{OUT} = V_{DD} - 0.1\text{ V}$ or
 $V_{OUT} = 0\text{ V}$

7. Sink current

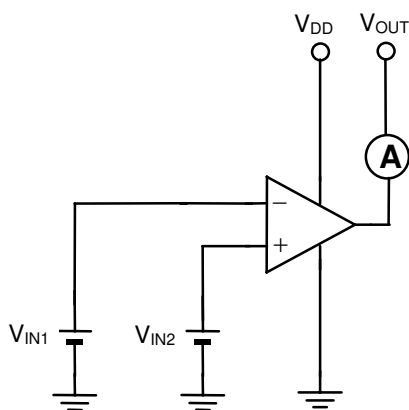

Figure 13

- Sink current (I_{SINK})
Measurement conditions: $V_{IN1} = \frac{V_{DD}}{2} + 0.1\text{ V}$
 $V_{IN2} = \frac{V_{DD}}{2} - 0.1\text{ V}$
 $V_{OUT} = 0.1\text{ V}$ or
 $V_{OUT} = V_{DD}$

8. Propagation delay time/transient response time

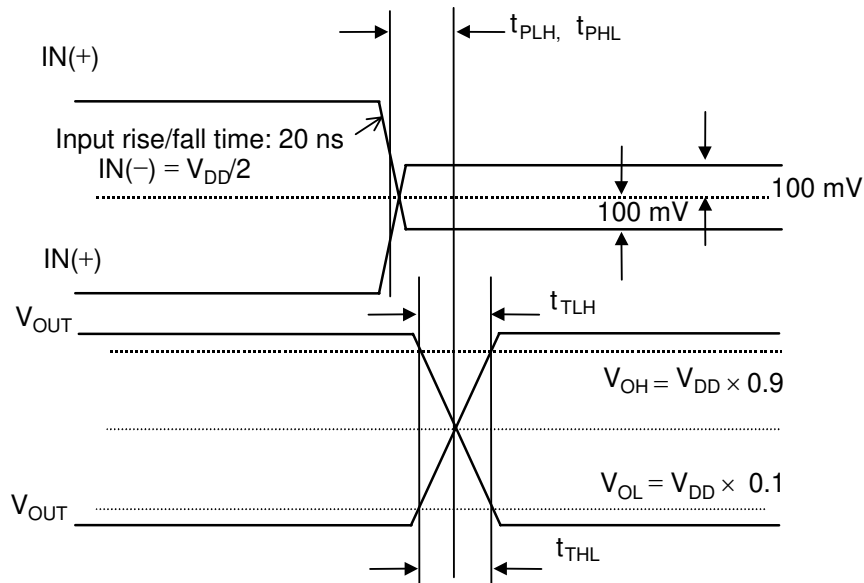

Figure 14

■ Cautions

- When $R_L = 100 \text{ k}\Omega$, V_{OH} may rise only 0.65 V if the temperature is -40°C and $V_{DD} = 0.9 \text{ V}$.
 If the temperature is -20°C , however, V_{OH} rises to 0.8 V, which is 100 mV below V_{DD} , when $V_{DD} = 0.9 \text{ V}$, even if $R_L = 100 \text{ k}\Omega$.
 If V_{DD} is 1.2 V, V_{OH} rises to 0.88 V, which is 20 mV below V_{DD} when $R_L = 100 \text{ k}\Omega$, even at -40°C .
 The temperature characteristics data described above can be used as reference data. Note that 100% testing under these conditions has not been performed.
- Be sure to use the product with a source current of no more than 7 mA.
- Do not apply an electrostatic discharge to this IC that exceeds the performance ratings of the built-in electrostatic protection circuit.

■ Characteristics (Reference Data)

1. Current consumption vs. Power supply voltage

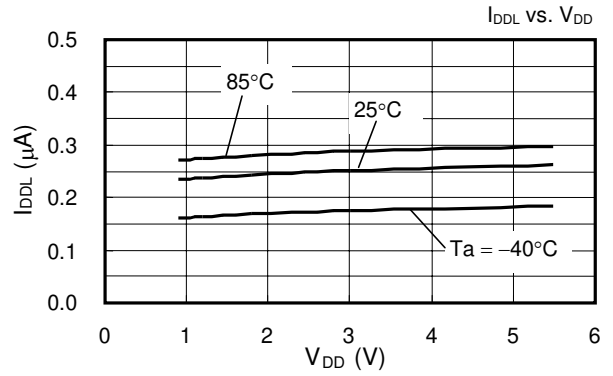
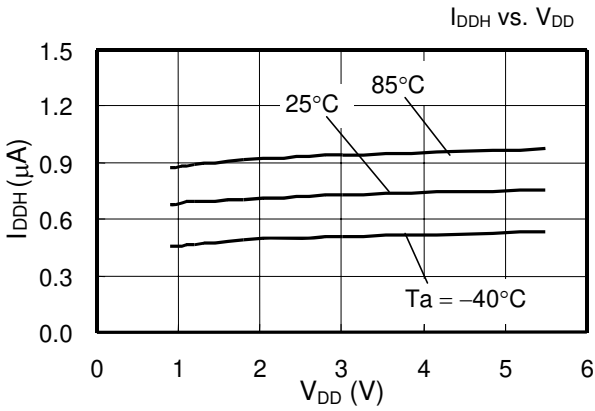

2. Output current

2-1. I_{SOURCE} vs. Power supply voltage

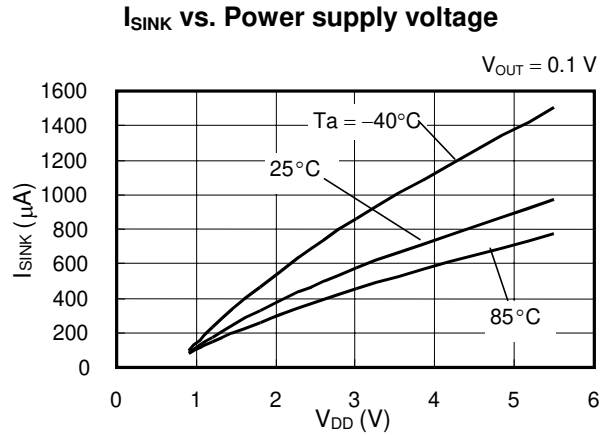
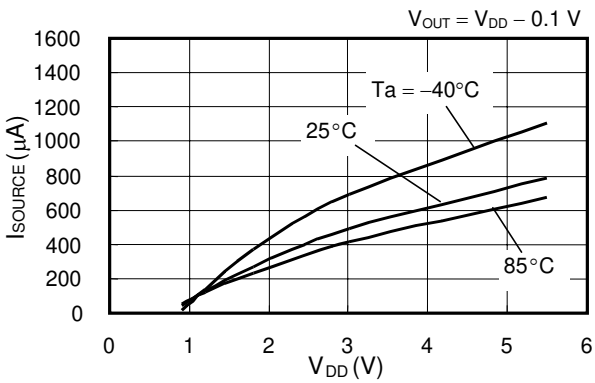

2-2. Output voltage (V_{OH}) vs. I_{SOURCE}

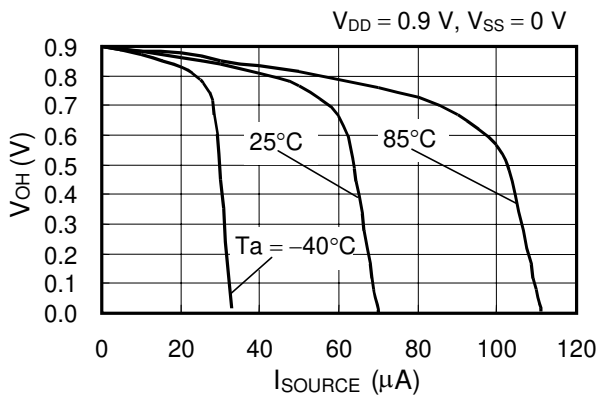
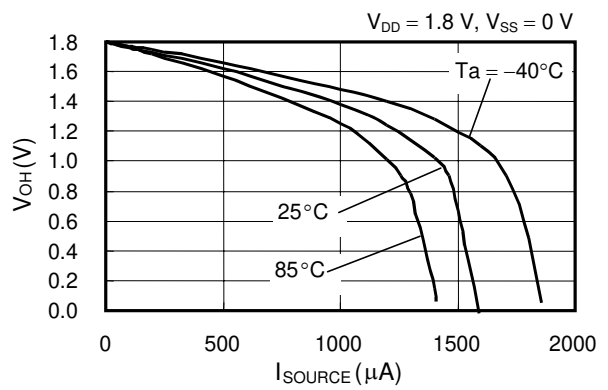
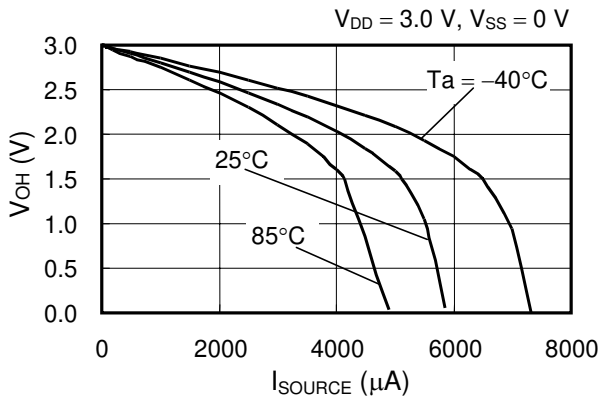

2-3. Output Voltage (V_{OL}) vs. I_{SINK}

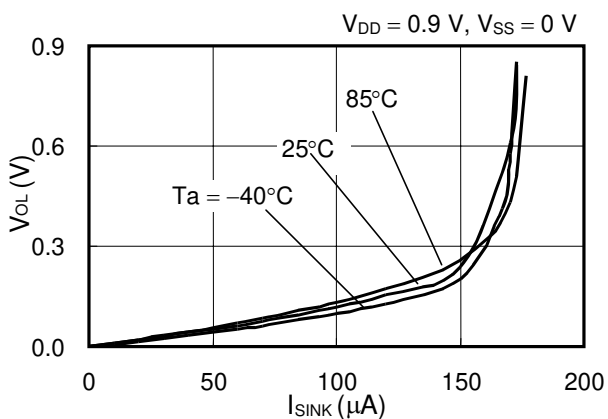
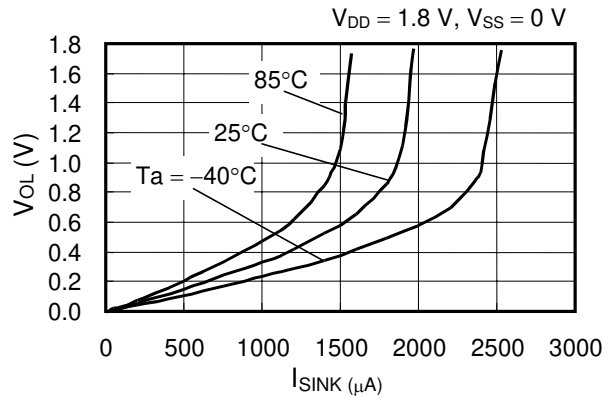
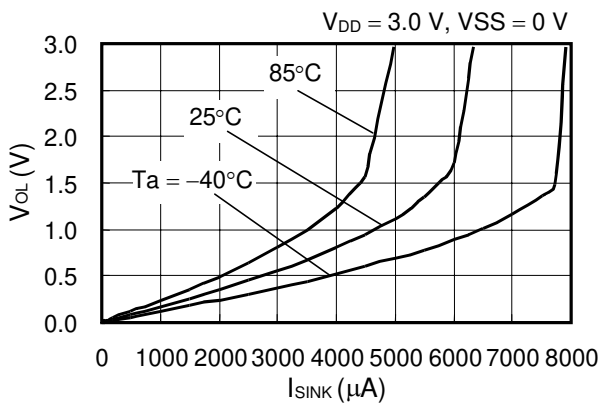

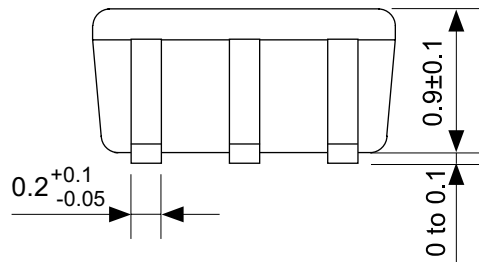
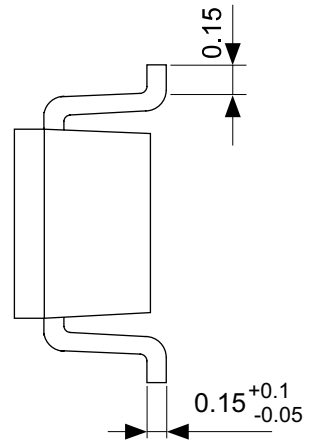
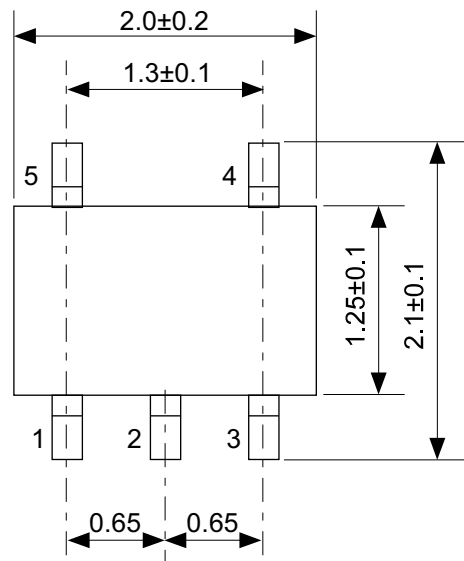

No. NP005-B-P-SD-1.1

TITLE	SC88A-B-PKG Dimensions
No.	NP005-B-P-SD-1.1
SCALE	
UNIT	mm
Seiko Instruments Inc.	

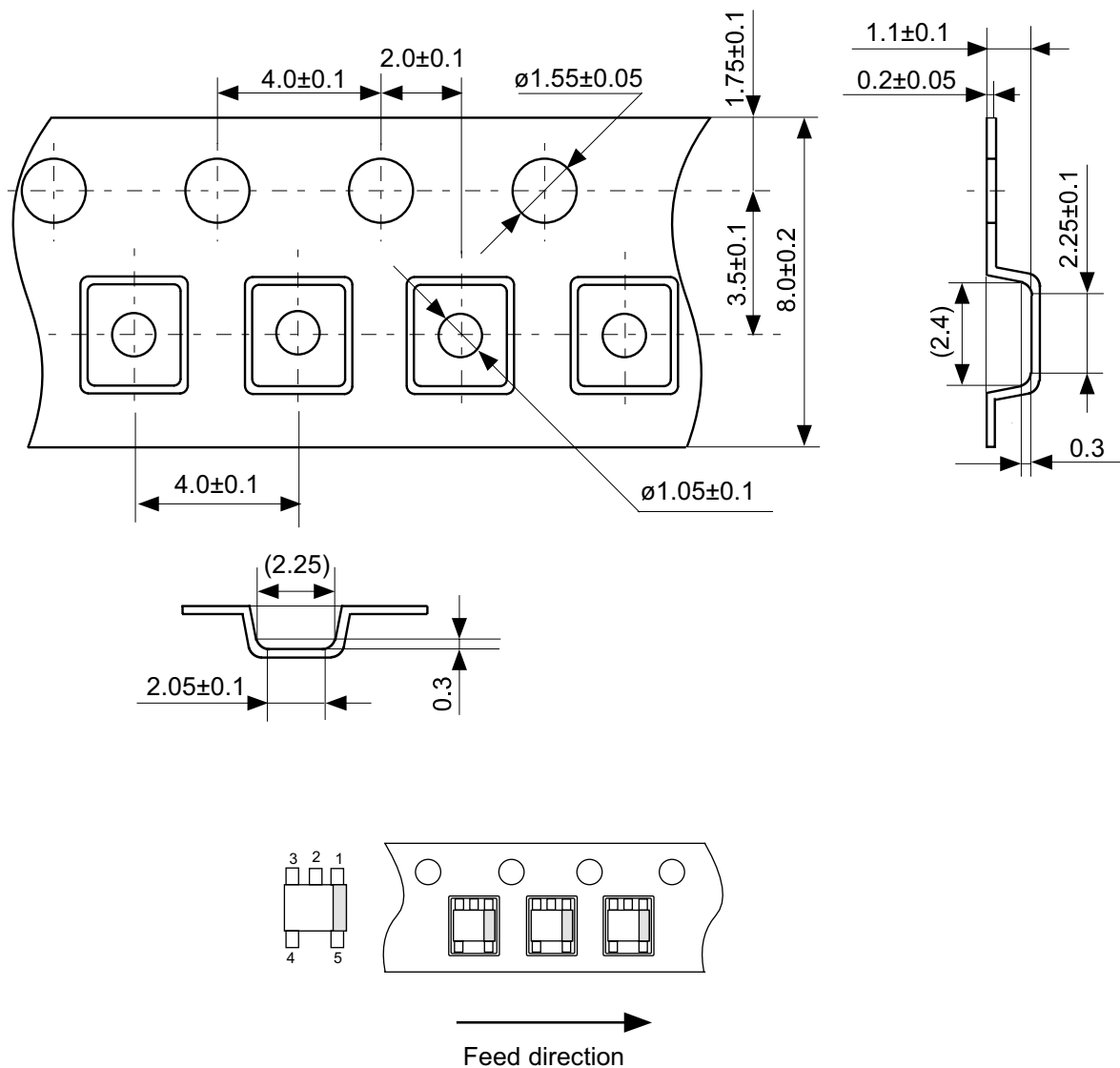

No. NP005-B-C-SD-2.0

TITLE	SC88A-B-Carrier Tape
No.	NP005-B-C-SD-2.0
SCALE	
UNIT	mm
Seiko Instruments Inc.	

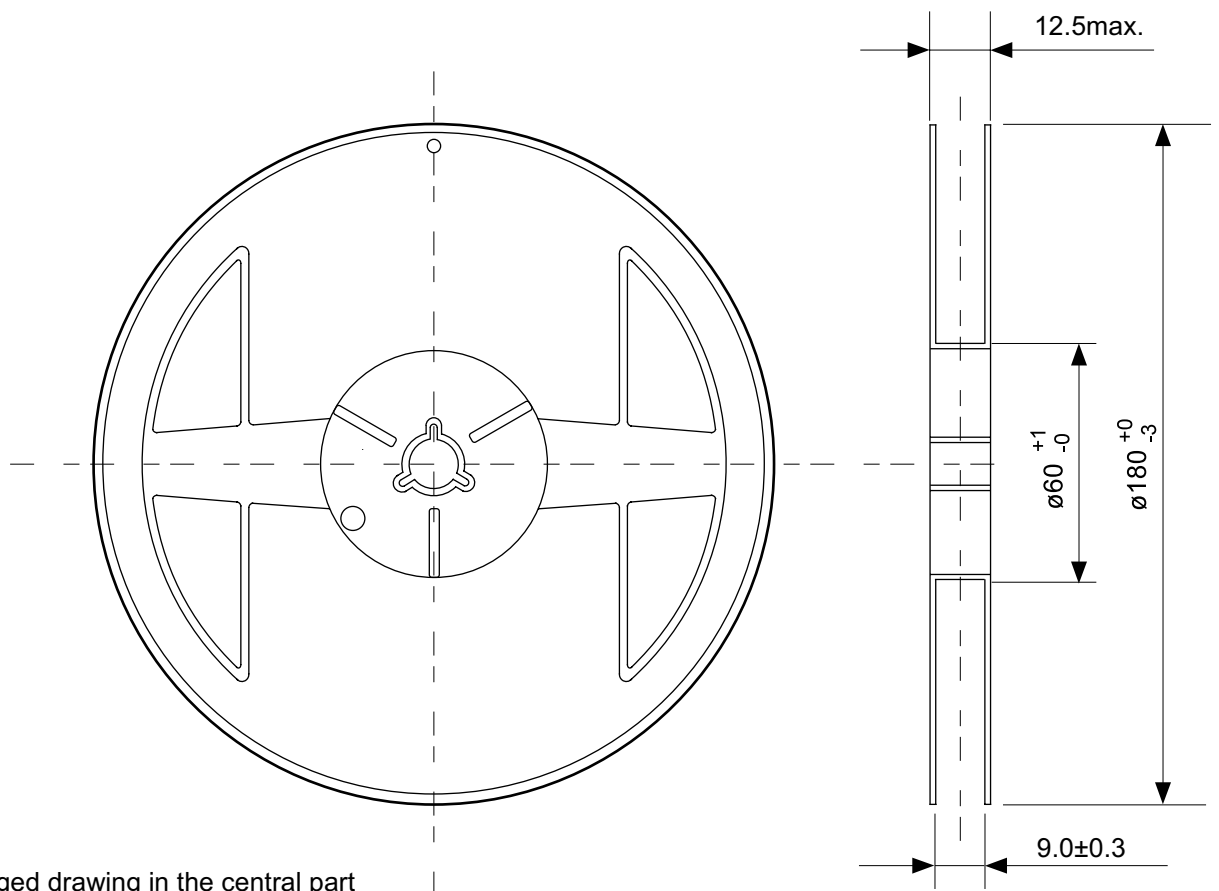

Enlarged drawing in the central part

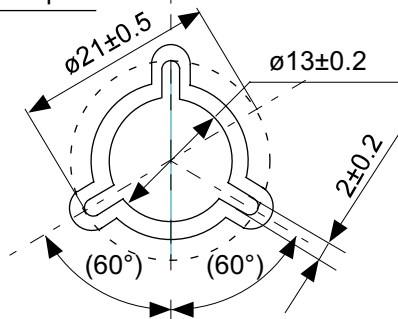

No. NP005-B-R-SD-2.1

TITLE	SC88A-B-Reel		
No.	NP005-B-R-SD-2.1		
SCALE		QTY.	3000
UNIT	mm		
Seiko Instruments Inc.			



Seiko Instruments Inc.
www.sii-ic.com

- The information described herein is subject to change without notice.
- Seiko Instruments Inc. is not responsible for any problems caused by circuits or diagrams described herein whose related industrial properties, patents, or other rights belong to third parties. The application circuit examples explain typical applications of the products, and do not guarantee the success of any specific mass-production design.
- When the products described herein are regulated products subject to the Wassenaar Arrangement or other agreements, they may not be exported without authorization from the appropriate governmental authority.
- Use of the information described herein for other purposes and/or reproduction or copying without the express permission of Seiko Instruments Inc. is strictly prohibited.
- The products described herein cannot be used as part of any device or equipment affecting the human body, such as exercise equipment, medical equipment, security systems, gas equipment, or any apparatus installed in airplanes and other vehicles, without prior written permission of Seiko Instruments Inc.
- The products described herein are not designed to be radiation-proof.
- Although Seiko Instruments Inc. exerts the greatest possible effort to ensure high quality and reliability, the failure or malfunction of semiconductor products may occur. The user of these products should therefore give thorough consideration to safety design, including redundancy, fire-prevention measures, and malfunction prevention, to prevent any accidents, fires, or community damage that may ensue.