



Chipsmall Limited consists of a professional team with an average of over 10 year of expertise in the distribution of electronic components. Based in Hongkong, we have already established firm and mutual-benefit business relationships with customers from,Europe,America and south Asia,supplying obsolete and hard-to-find components to meet their specific needs.

With the principle of "Quality Parts,Customers Priority,Honest Operation,and Considerate Service",our business mainly focus on the distribution of electronic components. Line cards we deal with include Microchip,ALPS,ROHM,Xilinx,Pulse,ON,Everlight and Freescale. Main products comprise IC,Modules,Potentiometer,IC Socket,Relay,Connector.Our parts cover such applications as commercial,industrial, and automotives areas.

We are looking forward to setting up business relationship with you and hope to provide you with the best service and solution. Let us make a better world for our industry!



## Contact us

Tel: +86-755-8981 8866 Fax: +86-755-8427 6832

Email & Skype: info@chipsmall.com Web: www.chipsmall.com

Address: A1208, Overseas Decoration Building, #122 Zhenhua RD., Futian, Shenzhen, China



# **S1V30120**

## **Hardware Specification**

## NOTICE

---

No part of this material may be reproduced or duplicated in any form or by any means without the written permission of Seiko Epson. Seiko Epson reserves the right to make changes to this material without notice. Seiko Epson does not assume any liability of any kind arising out of any inaccuracies contained in this material or due to its application or use in any product or circuit and, further, there is no representation that this material is applicable to products requiring high level reliability, such as, medical products. Moreover, no license to any intellectual property rights is granted by implication or otherwise, and there is no representation or warranty that anything made in accordance with this material will be free from any patent or copyright infringement of a third party. This material or portions thereof may contain technology or the subject relating to strategic products under the control of the Foreign Exchange and Foreign Trade Law of Japan and may require an export license from the Ministry of Economy, Trade and Industry or other approval from another government agency.

All other product names mentioned herein are trademarks and/or registered trademarks of their respective companies.

©SEIKO EPSON CORPORATION 2008, All rights reserved.



Fonix DECTalk(R) and Fonix Logo are registered trademarks of Fonix Corporation.



The ARM Powered Logo is a registered trademark of ARM Limited.

All other trademarks are the property of their respective owners.

## Table of Contents

<b>1. Outline</b>	<b>1</b>
<b>2. Features</b>	<b>1</b>
<b>3. Pinout Diagram (Top View)</b>	<b>2</b>
<b>4. Pin Description</b>	<b>3</b>
<b>5. Function Description</b>	<b>5</b>
5.1 Typical Application System	5
<b>6. Electrical Characteristics</b>	<b>6</b>
6.1 Absolute Maximum Rating	6
6.2 Recommended Operating Conditions	6
6.3 DC Characteristics	8
6.4 AC Characteristics	11
6.4.1 Clock Timing	11
6.4.2 Initialization Timing	12
6.4.2.1 Power-on/Reset Timing	12
6.4.2.2 Power-off Sequence	13
6.4.3 Clock Synchronous Serial Interface (SPI)	14
6.5 Full-Digital Audio Amplifier	15
<b>7. External Connection Example</b>	<b>16</b>
7.1 Connection Example: Clock Synchronous Serial Interface	16
<b>8. Package Dimensions</b>	<b>17</b>

### 1. Outline

The S1V30120 is a Speech Synthesis IC that provides a cost effective solution for adding Text-To-Speech (TTS) and ADPCM speech processing applications to a range of portable devices. The highly integrated design reduces overall system cost and time-to-market. The S1V30120 contains all the required analogue codecs, memory, and EPSON-supplied embedded algorithms. All applications are controlled over a single serial interface (SPI) allowing control from a wide range of hosts and rapid integration into existing products.

### 2. Features

- Text To Speech Synthesis (TTS)
  - Fonix DECTalk® v5, fully parametric speech synthesis
  - Languages: US English, Castilian Spanish, Latin American Spanish
  - Nine pre-defined voices
  - Sampling rate: 11.025kHz
- Audio reproduction (ADPCM)
  - ADPCM decoding (in Epson's original format)
  - Bit rate: 80kbps, 64kbps, 48kbps, 40kbps, 32kbps and 24kbps
  - Sampling rate: 16, 8 kHz
- Host interface
  - Synchronous serial interface (SPI interface is supported)
  - Command control
- 16-bit full-digital amplifier
  - Sampling rate (fs): 16, 11.025 and 8 kHz
  - Digital Input: 16 bits
  - Operating voltage: 3.3/1.8V
- Clock
  - 32.768KHz
- Package
  - 64-pin TQFP (10mm x 10mm) with 0.5mm-pitch pins
- Supply voltage
  - 3.3V (I/O power supply)
  - 1.8V (Core power supply)

### 3. Pinout Diagram (Top View)

### 3. Pinout Diagram (Top View)

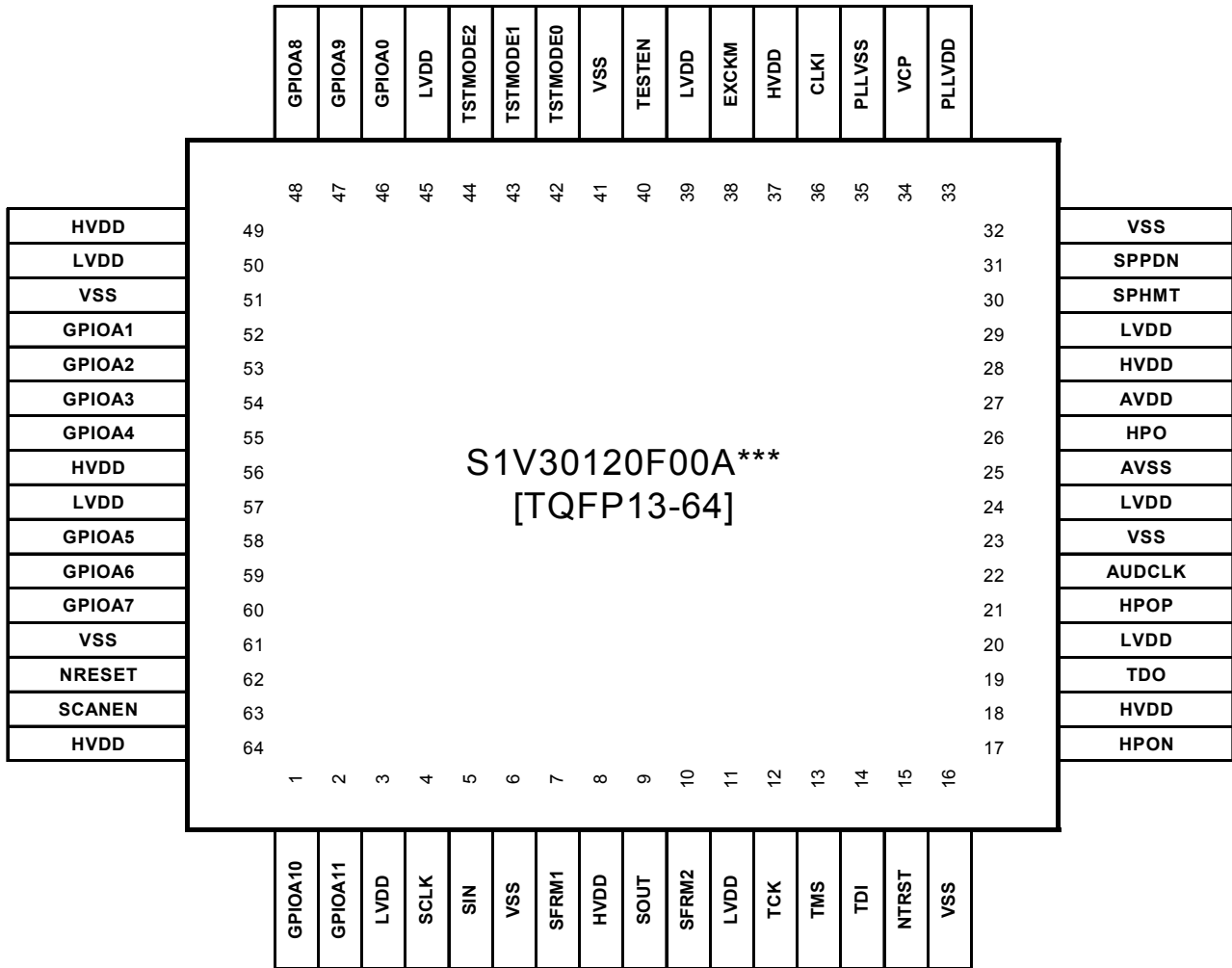

Fig. 3-1 TQFP13-64 Package Pinout

## 4. Pin Description

- Symbols

I = Input pin

O = Output pin

IO = Bi-directional pin

P = Power pin

Z = High impedance

### I/O cells

Symbol	Function
IC	LVC MOS input
IH	LVC MOS Schmitt-level input
ICP1	LVC MOS input with pull-up resistor (50kΩ when 3.3V (typ))
ICD2	LVC MOS input with pull-down resistor (100kΩ when 3.3V (typ))
O1	Output buffer (2mA/-2mA output current when 3.3V (typ))
O3	Output buffer (8mA/-8mA output current when 3.3V (typ))
T1	3-state output buffer (2mA/-2mA output current when 3.3V (typ))
BC1	Bi-directional IO buffer (2mA/-2mA output current when 3.3V (typ))
BC1P2	Bi-directional IO buffer with pull-up resistor (100kΩ when 3.3V (typ)) (2mA/-2mA output current when 3.3V (typ))
BC1D2	Bi-directional IO buffer with pull-down resistor (100kΩ when 3.3V (typ)) (2mA/-2mA output current when 3.3V (typ))
BC3D2	Bi-directional IO buffer with pull-down resistor (100kΩ when 3.3V (typ)) (8mA/-8mA output current when 3.3V (typ))
LOT	Transparent Output
ITST1	Test input with pull-down resistor (120kΩ when 1.8V (typ))

### Clock synchronous serial interface

Pin Name	Pin	I/O	I/O Cell Type	RESET# State	Power	Pin Description
SIN	5	IO	BC1	Z	HVDD	Serial data input
SCLK	4	IO	BC1	Z	HVDD	Serial clock input
SFRM1	7	IO	BC3P2	Z	HVDD	Slave device select input
SOUT	9	IO	BC3P2	Pull-up	HVDD	Serial data output
SFRM2	10	IO	O3	L	HVDD	Master device select output

### GPIO

Pin Name	Pin	I/O	I/O Cell Type	RESET# State	Power	Pin Description
GPIOA[11:0]	2,1,47,48,60,59,58,55,54,53,52,46	IO	BC1D2	Pull-down	HVDD	General-purpose IO port

## 4. Pin Description

### Full-digital audio amplifier

Pin Name	Pin	I/O	I/O Cell Type	RESET# State	Power	Pin Description
HPO	26	O	LOT	L	AVDD	Audio output
HPON	17	O	O1	L	HVDD	Inverted, unbuffered –digital- version of HPO
AUDCLK	22	O	O1	L	HVDD	Audio PWM clock
HPOP	21	O	O1	H	HVDD	Unbuffered –digital- version of HPO
SPPDN	31	O	O1	L	HVDD	Open in normal operation
SPHMT	30	O	O1	L	HVDD	Audio output in output period (Low active)

### Clock/Reset

Pin Name	Pin	I/O	I/O Cell Type	RESET# State	Power	Pin Description
CLKI	36	I	IC	Z	HVDD	Reference clock input (32.768kHz)
NRESET	62	I	IH	Z	HVDD	Reset input (Low active)

### Test

Pin Name	Pin	I/O	I/O Cell Type	RESET# State	Power	Pin Description
TSTMODE[2:0]	44, 43, 42	I	IC	Z	HVDD	Test pin (Set to low in normal operation)
TESTEN	40	I	ITST1	Pull-down	LVDD	Test pin (Set to low in normal operation)
SCANEN	63	I	IBD2	Pull-down	HVDD	Test pin (Set to low in normal operation)
EXCKM	38	I	IC	Z	HVDD	Test pin (Set to low in normal operation)
NTRST	15	I	IH	Z	HVDD	Test pin (Set to low in normal operation)
TDI	14	I	ICP1	Pull-up	HVDD	Test pin (Set to high in normal operation)
TMS	13	I	ICP1	Pull-up	HVDD	Test pin (Set to high in normal operation)
TCK	12	I	ICP1	Pull-up	HVDD	Test pin (Set to high in normal operation)
TDO	19	O	T1	Z	HVDD	Test pin (Open in normal operation)
VCP	34	O	LOT	Z	PLLVD	Test pin (Open in normal operation)

### Power supply

Pin Name	Pin	I/O	Pin Description
HVDD	8,18,28,37,49,56,64	P	Power supply for I/O buffers (3.3V)
LVDD	3,11,20,24,29,39,45,50,57	P	Power supply for the internal circuit (1.8V)
PLLVD	33	P	Power supply for PLL (1.8V)
AVDD	27	P	Power supply for full-digital amplifier (1.8V / 3.3V)
VSS	6,16,23,32,41,51,61	P	GND (I/O, internal circuit)
PLLVSS	35	P	GND (PLL)
AVSS	25	P	GND (Full-digital amplifier)



## 5. Function Description

### 5.1 Typical Application System

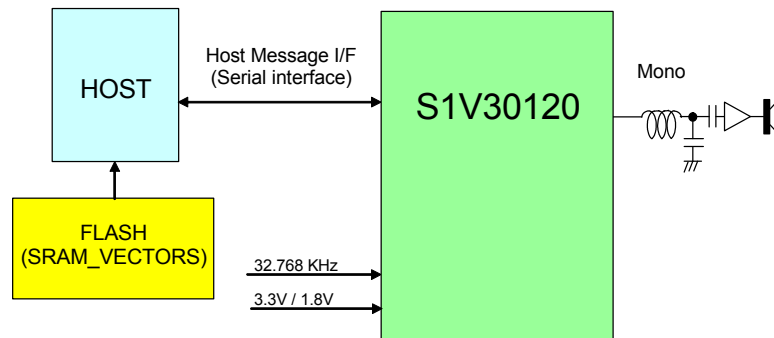

**Fig. 5-1 Standard Application system**

Fig. 5-1 illustrates a typical application system using the S1V30120. The host processor communicates with the S1V30120 over the serial interface, using commands (message protocol) to control the embedded algorithms. For more information on commands, see “S1V30120 Message Protocol Specification.”

On reset the S1V30120 runs the bootstrap loader firmware. The host must then use bootstrap loader messages to load the SRAM firmware contents and ROM firmware updates (SRAM\_VECTORS) into the S1V30120 device’s SRAM and to switch to running the main mode. These SRAM\_VECTORS are stored in FLASH in the typical application system shown in Fig. 5-1 above.

Refer to section 4 of the S1V30120 message protocol specification for details of the bootstrap loader messages and section 5 for details of the the main mode messages.

## 6. Electrical Characteristics

## 6. Electrical Characteristics

### 6.1 Absolute Maximum Rating

(VSS=0[V])

Parameter	Symbol	Rated Value	Unit
Supply voltage	HVDD	VSS-0.3 ~+4.0	V
	LVDD	VSS-0.3~+2.5	V
	PLLVD	VSS-0.3 ~ +2.5	V
	AVDD	VSS-0.3 ~ +4.0	V
Input voltage	HVI	VSS-0.3 ~ HVDD+0.5	V
	LVI	VSS-0.3 ~ LVDD+0.5	V
Output voltage	HVO	VSS-0.3 ~ HVDD+0.5	V
	AVO	VSS-0.3 ~ HVDD+0.5	V
Output current/pin (Except HPO)	IOUT	±10	mA
Storage temperature	Tstg	-65 ~ +150	°C

### 6.2 Recommended Operating Conditions

(VSS=0[V])

Parameter	Symbols	Min.	Typ.	Max.	Unit
Supply voltage	HVDD	3.00	3.30	3.60	V
	LVDD	1.65	1.80	1.95	V
	PLLVD	1.65	1.80	1.95	V
	AVDD	1.65	1.80	1.95	V
		3.00	3.30	3.60	V
Input voltage	HVI	VSS	-	HVDD	V
	LVI	VSS	-	LVDD	V
Ambient temperature	Ta	-40	25	85	°C

Take the following sequences for powering on or off the IC:

**(When AVDD=1.8V)**

**Power on: LVDD/PLLVD/AVDD => HVDD**

**Power off: HVDD => LVDD/PLLVD/AVDD**

**(When AVDD=3.3V)**

**Power on: LVDD/PLLVD => HVDD/AVDD**

**Power off: HVDD/AVDD => LVDD/PLLVD**

Notes:

- Do not apply voltage only to HVDD longer than a second with LVDD, PLLVD and AVDD turned off, or the product reliability may be harmed.

- When returning HVDD from the off-state to the on-state, the state of the internal circuit is not guaranteed due to power supply noise, etc. Therefore, be sure to initialize the circuit by NRESET after the IC power-up.

## 6. Electrical Characteristics

### 6.3 DC Characteristics

The DC input characteristics (based on Section 6.2 Recommended Operating Conditions)

Parameter	Symbol	Condition	Min.	Typ.	Max.	Unit
Supply current						
Supply current <sup>1</sup>	IDDH	HVDD=3.3V	-	0.05	-	mA
	IDDL	LVDD=1.8V	-	20.0	-	mA
	IDDP	PLLVD=1.8V	-	1.5	-	mA
	IDDAL	AVDD=1.8V, no load	-	0.4	-	mA
	IDDAH	AVDD=3.3V, no load	-	1.0	-	mA
Static current						
Supply current <sup>2</sup>	IDDSH	VIN = HVDD or VSS	-	2.0	-	μA
	IDDSL	HVDD=3.6V	-	5.0	-	μA
	IDDSP	LVDD=PLLVD=1.95V	-	0.2	-	μA
	IDDSA	AVDD=3.6V	-	0.3	-	μA
Input leakage						
Input leakage current	IL	HVDD=3.6V LVDD=1.95V PLLVD=1.95V AVDD=3.6V HVIH=HVDD LVIH=LVDD VIL=VSS	-5	-	5	μA

1: Approximate current values during the Text to Speech Synthesis under the recommended operating conditions (Ta=25°C)

2: Static current under the recommended operating conditions (Ta=25°C)

## 6. Electrical Characteristics

The DC input characteristics (based on Section 6.2, Recommended Operating Conditions)  
(Continued)

Parameter	Symbol	Condition	Min.	Typ.	Max.	Unit
Input characteristic (LVCMOS)	Pin names: SIN, SCLK, SFRM1, SOUT, GPIOA[11:0], CLKI, TSTMODE[2:0], SCANEN, EXCKM, TDI, TMS, TCK					
H-level input voltage	HVIH	HVDD=3.6V	2.2	-	-	V
L-level input voltage	HVIL	HVDD=3.0V	-	-	0.8	V
Input characteristic (LVCMOS)	Pin name: TESTEN					
H-level input voltage	LVIH	LVDD=1.95V	1.27	-	-	V
L-level input voltage	LVIL	LVDD=1.65V	-	-	0.57	V
Schmitt input characteristic (LVCMOS)	Pin names: NRESET, NTRST					
H-level input voltage	VT+	HVDD=3.6V	1.4	-	2.7	V
L-level input voltage	VT-	HVDD=3.0V	0.6	-	1.8	V
Hysteresis voltage	$\Delta V$	HVDD=3.0V	0.3	-	-	V
Input characteristic	Pin name: TDI, TMS, TCK					
Pull-up resistance	RPU1	VI=VSS	25	50	120	k $\Omega$
Input characteristic	Pin name: SFRM1, SOUT					
Pull-up resistance	RPU2	VI=VSS	50	100	240	k $\Omega$
Input characteristic	Pin name: GPIOA[11:0], SCANEN					
Pull-down resistance	RPD1	VI=HVDD	50	100	240	k $\Omega$
Input characteristic	Pin name: TESTEN					
Pull-down resistance	RPD2	VI=LVDD	48	120	300	k $\Omega$

## 6. Electrical Characteristics

Parameter	Symbol	Condition	Min.	Typ.	Max.	Unit
Output characteristic	Pin names: SIN, SCLK, GPIOA[11:0], AUDCLK, HPOP, SPPDN, SPHMT, TDO, HPON					
H-level output voltage	VOH1	HVDD=3.0V IOH=-2mA	HVDD-0.4	-	-	V
L-level output voltage	VOL1	HVDD=3.0V IOL=2mA	-	-	VSS+0.4	V
Output characteristic	Pin name: SOUT, SFRM1, SFRM2					
H-level output voltage	VOH2	HVDD=3.0V IOH=-8mA	HVDD-0.4	-	-	V
L-level output voltage	VOL2	HVDD=3.0V IOL=8mA	-	-	VSS+0.4	V
Output characteristic	Pin names: SIN, SCLK, SFRM1, SFRM2, SPPDN, SPHMT, AUDCLK, HPOP, HPON, SOUT, GPIOA[11:0], TDO					
Off-state leakage current	IOZ	HVDD=3.6V HVOH=HVDD VOL=VSS	-5	-	5	μA

Parameter	Symbol	Condition	Min.	Typ.	Max.	Unit
Output characteristic	Pin names: All input pins					
Input pin capacitance	CI	f=1MHz HVDD=LVDD=AVDD= PLLVD=0V	-	-	8	pF
Pin capacitance	Pin names: All output pins except HPO					
Output pin capacitance	CO1	f=1MHz HVDD=LVDD=AVDD= PLLVD=0V	-	-	8	pF
Pin capacitance	Pin names: All output pins					
I/O pin capacitance	CIO	f=1MHz HVDD=LVDD=AVDD= PLLVD=0V	-	-	8	pF

## 6.4 AC Characteristics

### 6.4.1 Clock Timing

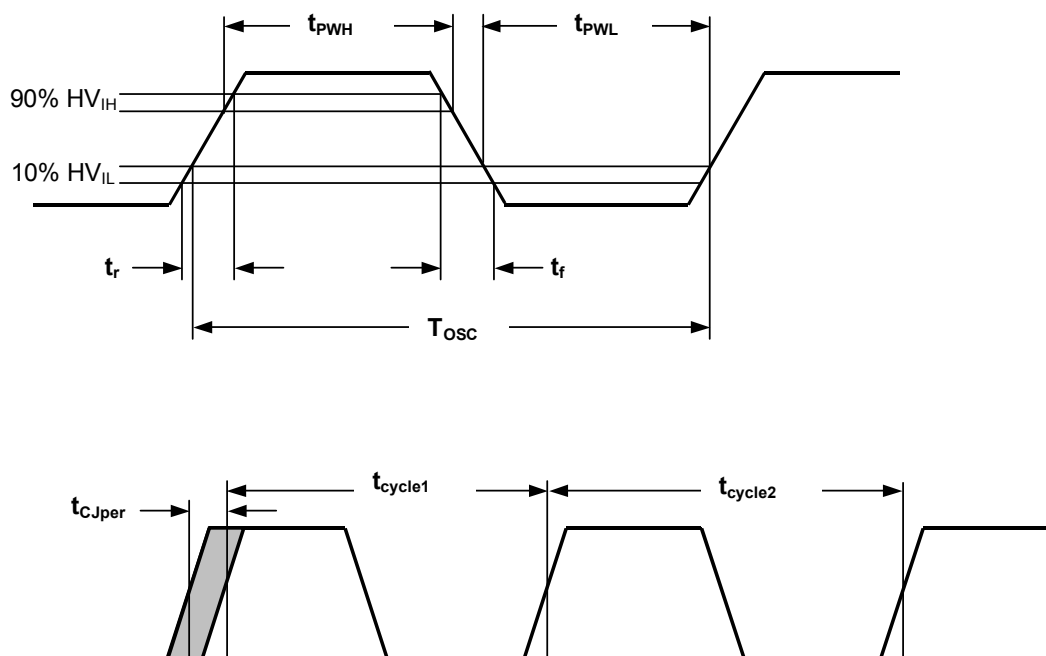

Fig. 6-1 Clock Timing

Symbol	Parameter	Min.	Typ.	Max.	Unit
$f_{osc}$	Input clock frequency	-	32.768	-	kHz
$T_{osc}$	Input clock period	-	$1/f_{osc}$	-	$\mu s$
$t_{pwh}$	Input clock pulse width high	5	-	-	$\mu s$
$t_{pwl}$	Input clock pulse width low	5	-	-	$\mu s$
$t_r$	Input clock rising time (10% $\rightarrow$ 90%)	-	-	12	$\mu s$
$t_f$	Input clock falling time (90% $\rightarrow$ 10%)	-	-	12	$\mu s$
$t_{Cjper}$	Input clock period jitter (*2, 4)	-10	-	10	ns
$t_{Cjcycle}$	Input clock cycle jitter (*1, 3, 4)	-10	-	10	ns
*1	$t_{Cjcycle} = t_{cycle1} - t_{cycle2}$				
*2	The input clock period jitter is the displacement relative to the center period (reciprocal of center frequency).				
*3	The input clock cycle jitter is difference in period between adjacent cycles.				
*4	The jitter characteristics must meet both $t_{Cjper}$ and $t_{Cjcycle}$ characteristics.				

## 6. Electrical Characteristics

### 6.4.2 Initialization Timing

#### 6.4.2.1 Power-on/Reset Timing

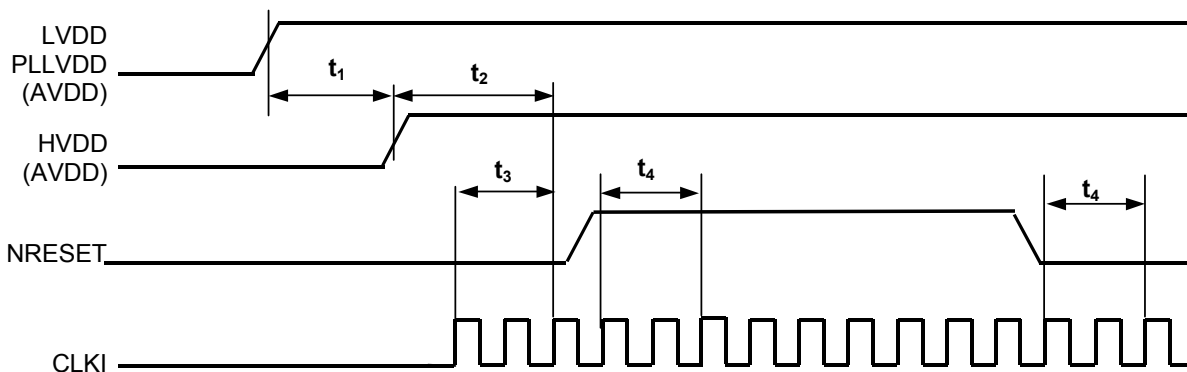

Fig. 6-2 Power-on/Reset Timing

Symbol	Parameter	Min.	Max.	Unit
$t_1$	Delay from the LVDD and PLLVDD (AVDD) power-on to HVDD (AVDD) power-on <sup>*1</sup>	10	-	$\mu\text{s}$
$t_2$	Minimum delay from the HVDD power-on to the CLK1 rising edge before NRESET release	100	-	$\mu\text{s}$
$t_3$	The minimum RESET assertion on system power up	2	-	$T_{\text{osc}}$ <sup>*2</sup>
$t_4$	NRESET synchronization time (Number of clock cycles before NRESET is applied internally)	2	-	$T_{\text{osc}}$ <sup>*2</sup>
*1	See Section 6.2 Recommended Operating Conditions.			
*2	$T_{\text{osc}}$ is the CLK1 clock period.			



6.4.2.2 Power-off Sequence

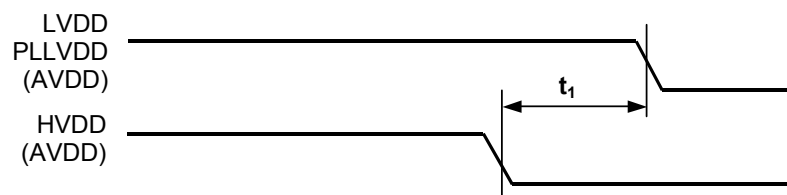
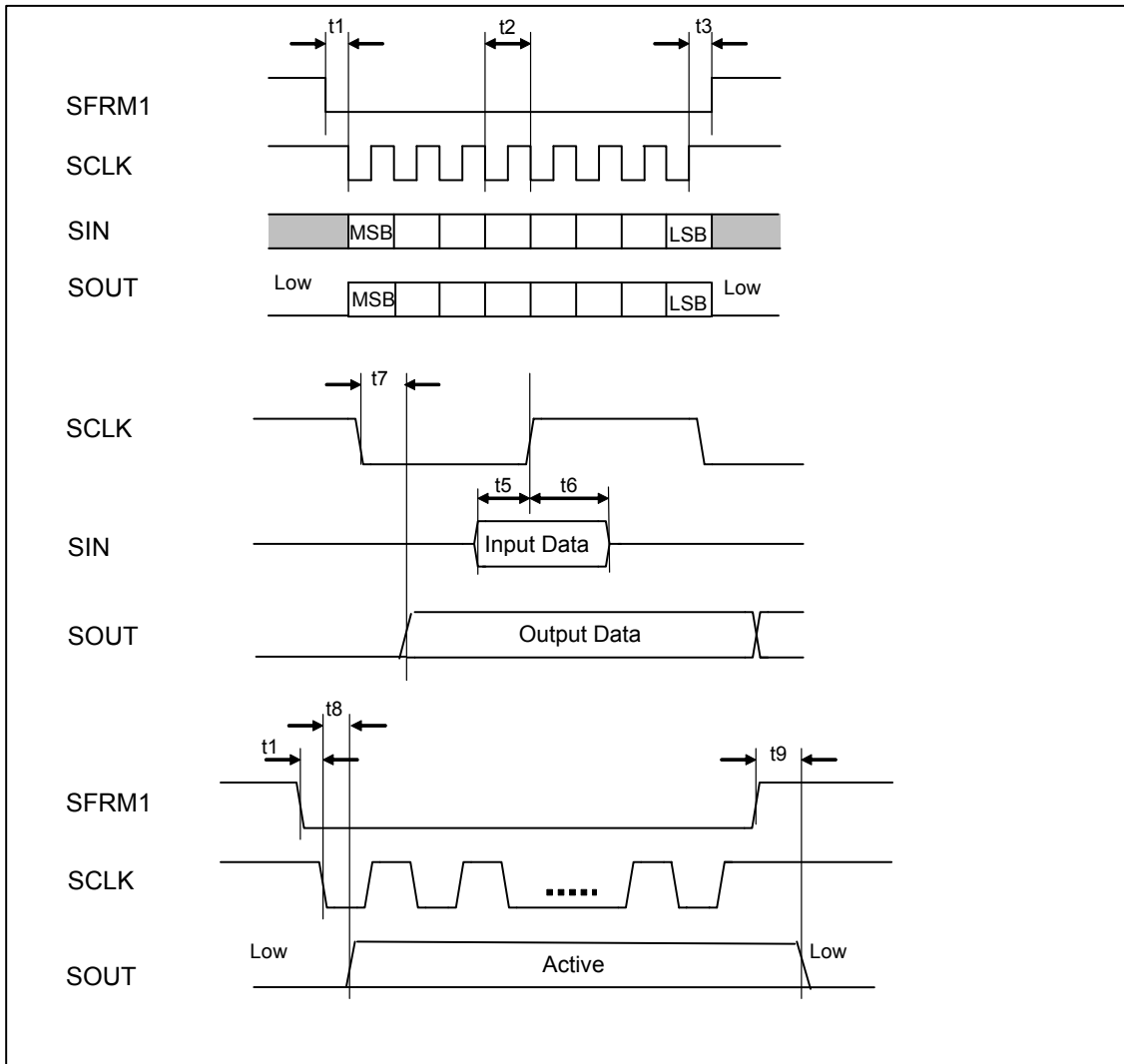

Fig. 6-3 Power-off Sequence

Symbol	Parameter	Min.	Max.	Unit
$t_1$	Delay from HVDD (AVDD) power-off to LVDD and PLLVDD (AVDD) power-off *1.	-	500	$\mu\text{s}$
*1	See Section 6.2, Recommended Operating Conditions.			

## 6. Electrical Characteristics

### 6.4.3 Clock Synchronous Serial Interface (SPI)



**Fig. 6-4 Clock Synchronous Serial Interface**

Symbol	Parameter	Min.	Max.	Unit
$t_1$	SFRM1 falling time to SCLK falling time	200	-	ns
$t_2$	SCLK cycle time	1.0	-	$\mu$ s
$t_3$	SCLK rising time to SFRM1 rising time	200	-	ns
$t_5$	SIN setup time	10	-	ns
$t_6$	SIN hold time	200	-	ns
$t_7$	SCLK falling time to SOUT going active	-	200	ns
$t_8$	SCLK falling time to SOUT going active with SFRM1=L	-	200	ns
$t_9$	SFRM1 rising time to SOUT going Low	-	250	ns

### 6.5 Full-Digital Audio Amplifier

The electrical characteristics of the full-digital audio amplifier are as follows unless otherwise noted:

- $T_a = 25^{\circ}\text{C}$
- $\text{HVDD} = 3.3\text{V}$ ,  $\text{LVDD} = 1.8\text{V}$ ,  $\text{PLLVD} = 1.8\text{V}$
- Input signal frequency = 1kHz
- Input signal level = 0dBFS
- $f_s = 32\text{kHz}$
- Test frequency range = 20Hz ~16kHz
- Load impedance =  $16\Omega$
- Connection to the 2<sup>nd</sup> low-pass filter to the output (HPO)

When AVDD = 1.8V

Parameter	Symbol	Condition	Min.	Typ.	Max.	Unit
Load impedance	$R_L$		16	-	-	$\Omega$
Output power	$P_o$		2	3	-	mW
Total harmonic distortion	THD+N	Input signal level = -6dBFS	-	0.13	0.25	%
Signal noise ratio	SNR		73	76	-	dB

When AVDD = 3.3V

Parameter	Symbol	Condition	Min.	Typ.	Max.	Unit
Load impedance	$R_L$		16	-	-	$\Omega$
Output power	$P_o$		8	11	-	mW
Total harmonic distortion	THD+N	Input signal level = -6dBFS	-	0.1	0.15	%
Signal noise ratio	SNR		79	82	-	dB

- Full Digital Amplifier characteristic may be deteriorated by AVDD Voltage fluctuation. Use stable power supplies for AVDD.

## 7. External Connection Example

---

## 7. External Connection Example

### 7.1 Connection Example: Clock Synchronous Serial Interface

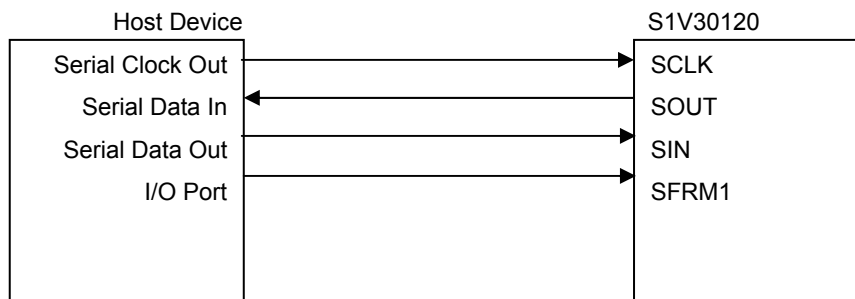
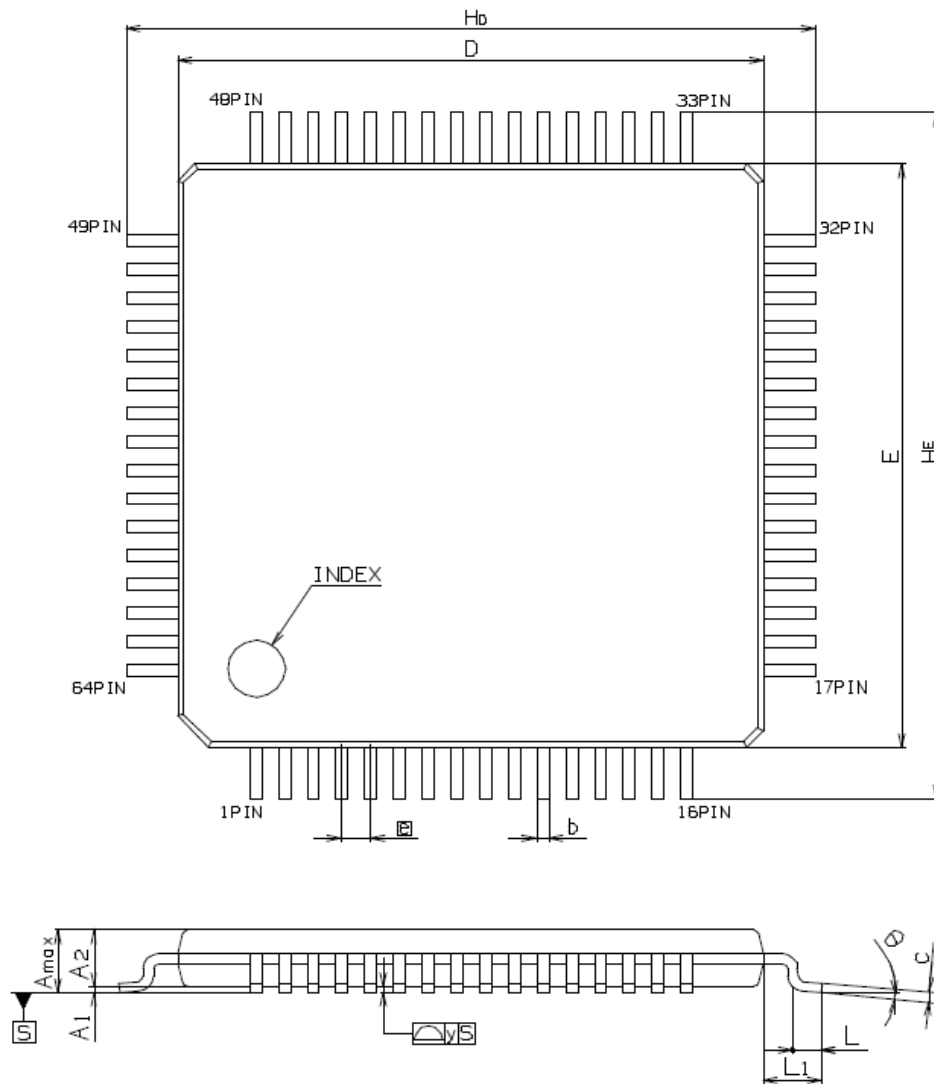

**Fig. 7-1 Clock Synchronous Serial Interface Connection Example**

Note:

When SFRM1 is Low, SOUT goes active. When SFRM1 is High, SOUT goes Low.

8. Package Dimensions



Symbol	Dimension in Millimeters		
	Min	Nom	Max
E	-	10	-
D	-	10	-
$A_{max}$	-	-	1.2
$A_1$	-	0.1	-
$A_2$	-	1	-
$\square$	-	0.5	-
b	0.17	-	0.27
c	0.09	-	0.2
$\theta$	0°	-	10°
L	0.3	-	0.75
$L_1$	-	1	-
$H_E$	-	12	-
$H_D$	-	12	-
y	-	-	0.08

Fig. 8-1 S1V30120F00A\*\*\* Dimensions

### AMERICA

---

#### EPSON ELECTRONICS AMERICA, INC.

##### HEADQUARTERS

2580 Orchard Parkway  
San Jose, CA 95131, USA  
Phone: +1-800-228-3964 FAX: +1-408-922-0238

##### SALES OFFICES

###### Northeast

301 Edgewater Place, Suite 210  
Wakefield, MA 01880, U.S.A.  
Phone: +1-800-922-7667 FAX: +1-781-246-5443

### EUROPE

---

#### EPSON EUROPE ELECTRONICS GmbH

##### HEADQUARTERS

Riesstrasse 15 Muenchen Bayern, 80992 GERMANY  
Phone: +49-89-14005-0 FAX: +49-89-14005-110

### ASIA

---

#### EPSON (CHINA) CO., LTD.

7F, Jinbao Bldg., No.89 Jinbao St., Dongcheng District,  
Beijing 100005, China  
Phone: +86-10-6410-6655 FAX: +86-10-6410-7320

##### SHANGHAI BRANCH

7F, Block B, Hi-Tech Bldg., 900, Yishan Road,  
Shanghai 200233, CHINA  
Phone: +86-21-5423-5522 FAX: +86-21-5423-5512

#### EPSON HONG KONG LTD.

20/F., Harbour Centre, 25 Harbour Road  
Wanchai, Hong Kong  
Phone: +852-2585-4600 FAX: +852-2827-4346  
Telex: 65542 EPSCO HX

#### EPSON (CHINA) CO., LTD.

##### SHENZHEN BRANCH

12/F, Dawning Mansion, Keji South 12th Road,  
Hi-Tech Park, Shenzhen  
Phone: +86-755-2699-3828 FAX: +86-755-2699-3838

#### EPSON TAIWAN TECHNOLOGY & TRADING LTD.

14F, No. 7, Song Ren Road,  
Taipei 110  
Phone: +886-2-8786-6688 FAX: +886-2-8786-6660

#### EPSON SINGAPORE PTE., LTD.

1 HarbourFront Place,  
#03-02 HarbourFront Tower One, Singapore 098633  
Phone: +65-6586-5500 FAX: +65-6271-3182

#### SEIKO EPSON CORPORATION

##### KOREA OFFICE

50F, KLI 63 Bldg., 60 Yoido-dong  
Youngdeungpo-Ku, Seoul, 150-763, KOREA  
Phone: +82-2-784-6027 FAX: +82-2-767-3677

##### GUMI OFFICE

2F, Grand B/D, 457-4 Songjeong-dong,  
Gumi-City, KOREA  
Phone: +82-54-454-6027 FAX: +82-54-454-6093

---

#### SEIKO EPSON CORPORATION

##### SEMICONDUCTOR OPERATIONS DIVISION

##### IC Sales Dept.

##### IC International Sales Group

421-8, Hino, Hino-shi, Tokyo 191-8501, JAPAN  
Phone: +81-42-587-5814 FAX: +81-42-587-5117