



Chipsmall Limited consists of a professional team with an average of over 10 year of expertise in the distribution of electronic components. Based in Hongkong, we have already established firm and mutual-benefit business relationships with customers from,Europe,America and south Asia,supplying obsolete and hard-to-find components to meet their specific needs.

With the principle of “Quality Parts,Customers Priority,Honest Operation,and Considerate Service”,our business mainly focus on the distribution of electronic components. Line cards we deal with include Microchip,ALPS,ROHM,Xilinx,Pulse,ON,Everlight and Freescale. Main products comprise IC,Modules,Potentiometer,IC Socket,Relay,Connector.Our parts cover such applications as commercial,industrial, and automotives areas.

We are looking forward to setting up business relationship with you and hope to provide you with the best service and solution. Let us make a better world for our industry!



## Contact us

Tel: +86-755-8981 8866 Fax: +86-755-8427 6832

Email & Skype: info@chipsmall.com Web: www.chipsmall.com

Address: A1208, Overseas Decoration Building, #122 Zhenhua RD., Futian, Shenzhen, China



## Voice Guidance LSI

### ■ Overview

The S1V3G340 is an LSI incorporating high-compression, high-quality audio decoding functions, external SPI flash memory interface, and a DA converter, making it ideal for use in voice guidance products. The voice data creation tool for EPSON voice guidance LSI allows easy creation of high-quality voice data without the need for studio recording. Use of external SPI flash memory allows easy interchanging of voice data. Additional voice data can be transferred from a host when required. General-purpose output ports are provided to allow flexible system design. All functions are controlled by commands via a serial interface for easy addition to any existing system incorporating a host.

### ■ Features

- **Audio playback**
  - High-compression, high-quality audio decoder (proprietary Epson data format)
  - Bitrate: 40 kbps, 32 kbps, 24 kbps, 16 kbps
  - Sampling rate: 16 kHz
- **Sequencer function (phrase interval setting)**
  - Sequence setting for up to 64 phrases (unlimited combinations)
  - Variable phrase interval delay setting: 0 ms or 20 ms to 2,047 ms (in 1 ms steps)
- **External SPI flash memory interface**
  - Clock synchronized serial interface (SPI)
  - Maximum approx. 128 mins (16 Mbytes)
- **GPO**
  - 7 pins
- **Host interface**
  - Clock synchronized serial interface, supporting UART and I2C
  - Command control
- **High-quality 16-bit DA converter**
  - Sampling rate ( $f_s$ ): 16 kHz
  - Input bits: 16 bits
- **Clock**
  - Clock input: 32.768 kHz or 12.288 MHz
  - Crystal oscillator: 32.768 kHz
- **Package**
  - QFP-52 pin (10 mm × 10 mm) 0.65 mm pin pitch
- **Power supply voltage**
  - 2.2 V to 5.5 V (single power supply)

### ■ Standard application system

The S1V3G340 standard application system is configured as shown in the diagram below. The S1V3G340 is command-controlled by the host using a messaging protocol via the serial interface. Controlled by commands sent from the host via the serial interface after power-on resetting, the S1V3G340 outputs voice audio while internally decoding and processing internal or streamed (via host command transfer) compressed audio data.

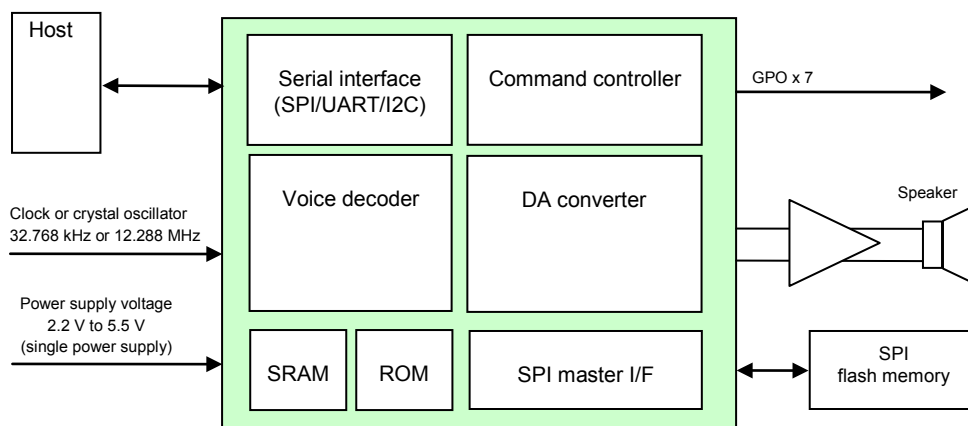

# S1V3G340

## Development Tools

- Evaluation board\*1
- Audio data creation tool
- Sample programs

[Voice data creation tool overview]

Step 1: Voice guidance registration

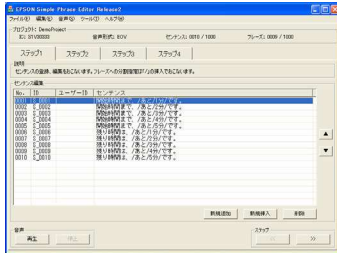

Step 2: Pronunciation editing

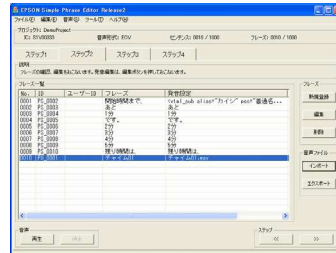

Step 3: Phrase editing

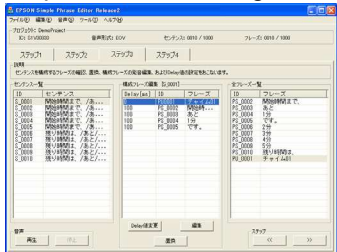

Step 4: ROM data production

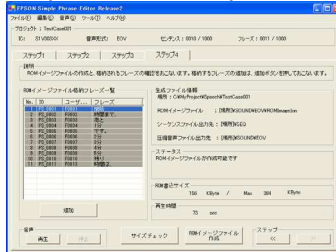

- Supported languages : English, Japanese, Korean (all female voices)

\*1 For evaluation of S1V3G340 use S1V3S344 Evaluation Board incorporating 512-KB flash memory.

### NOTICE:

No part of this material may be reproduced or duplicated in any form or by any means without the written permission of Seiko Epson. Seiko Epson reserves the right to make changes to this material without notice. Seiko Epson does not assume any liability of any kind arising out of any inaccuracies contained in this material or due to its application or use in any product or circuit and, further, there is no representation that this material is applicable to products requiring high level reliability, such as, medical products. Moreover, no license to any intellectual property rights is granted by implication or otherwise, and there is no representation or warranty that anything made in accordance with this material will be free from any patent or copyright infringement of a third party. When exporting the products or technology described in this material, you should comply with the applicable export control laws and regulations and follow the procedures required by such laws and regulations. You are requested not to use, to resell, to export and/or to otherwise dispose of the products (and any technical information furnished, if any) for the development and/or manufacture of weapon of mass destruction or for other military purposes.

All brands or product names mentioned herein are trademarks and/or registered trademarks of their respective companies.

©Seiko Epson Corporation 2015, All rights reserved

**SEIKO EPSON CORPORATION**

**MICRODEVICES OPERATIONS DIVISION**

Device Sales & Marketing Department  
421-8 Hino, Hino-shi, Tokyo 191-8501, JAPAN  
Phone: +81-42-587-5814 FAX: +81-42-587-5117

EPSON semiconductor website

<http://global.epson.com/products/semicon/>

Document code: 411675901  
First issue March, 2009  
Revised June, 2015 in Japan