



Chipsmall Limited consists of a professional team with an average of over 10 year of expertise in the distribution of electronic components. Based in Hongkong, we have already established firm and mutual-benefit business relationships with customers from,Europe,America and south Asia,supplying obsolete and hard-to-find components to meet their specific needs.

With the principle of "Quality Parts,Customers Priority,Honest Operation,and Considerate Service",our business mainly focus on the distribution of electronic components. Line cards we deal with include Microchip,ALPS,ROHM,Xilinx,Pulse,ON,Everlight and Freescale. Main products comprise IC,Modules,Potentiometer,IC Socket,Relay,Connector.Our parts cover such applications as commercial,industrial, and automotives areas.

We are looking forward to setting up business relationship with you and hope to provide you with the best service and solution. Let us make a better world for our industry!



Contact us

Tel: +86-755-8981 8866 Fax: +86-755-8427 6832

Email & Skype: info@chipsmall.com Web: www.chipsmall.com

Address: A1208, Overseas Decoration Building, #122 Zhenhua RD., Futian, Shenzhen, China





Smart Technology. Delivered.

Special Purpose Omnidirectional Antennas



OMNIDIRECTIONAL ANTENNAS FOR PCS/DCS AND WIRELESS LAN

Laird is world renowned for special purpose omnidirectional antenna design. Antennas are available for the 1.7 GHz DCS band through 5.8 GHz ISM band frequencies and can be suspension ceiling mounted, I-beam mounted or mast mounted.

2.4 GHz MONOPOLE OMNI

The Laird 2.4 GHz monopole antenna features a large backplane and is designed for applications with a very focused omnidirectional pattern where an in-building system is required. The monopole can be used to focus signal directly into an area where it is difficult to obtain any coverage.

ANTENNA SELECTION CRITERIA

Prior to making an informed antenna selection, the following must be determined: what frequency range should the antenna cover? What gain is needed? If the exact gain is unknown, be able to describe the system that will use the antennas. For example, how large is the area? What obstructions are in the area (i.e. buildings, trees, shelves, walls, etc.)? Consider how the antenna will be mounted or at least what mount is preferable. With this information, a number of alternatives can be eliminated.

Currently, the most popular spread spectrum systems operate in the 900 MHz or the 2.4 GHz ranges, so these are basic spread options. Other data applications occur anywhere from 25 MHz to 5.9 GHz. Some antennas outside of the 900 Mhz and 2.4 GHz ranges are also offered. Contact Laird to find your solution today!

FEATURES

- Polycarbonate enclosures
- Available with ceiling mounts
- Plated copper laminated radiator
- Weatherproof designs with UltraLink pigtails
- Broadband performance
- DC grounded
- Omnidirectional performance

MARKETS

- WiMAX

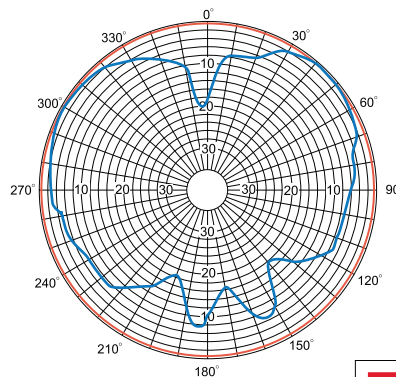

S2403M

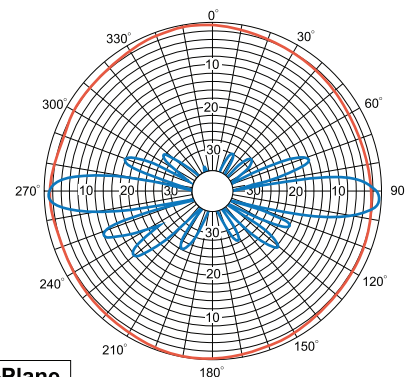

S2406BH



Americas: +1.847.839.6907
IAS-AmericasEastSales@lairdtech.com

Europe: +44.1628.858941
IAS-EUSales@lairdtech.com

Asia: +86.21.5855.0827.127
IAS-AsiaSales@lairdtech.com

www.lairdtech.com



Smart Technology. Delivered.

Special Purpose Omnidirectional Antennas

MODEL	FREQUENCY MHz	GAIN dBi	BANDWIDTH 1.5:1 MHz	-3 dB BEAMWIDTH E-PLANE	HEIGHT In (cm)	WEIGHT lb (kg)	W/SUR AREA ft ² (m ²)	W/SURVIVAL mph (kph)	POWER (watts)	ENCLOSURE MATERIAL	MOUNT STYLE	MAST DIAMETER in (cm)
S5703BP5SMF	5725-5875	3	150	38°	7 (17.8)	0.3 (0.14)	0.06 (0.006)	125 (200)	20	Polycarbonate Tube End		2 (5.1)
S5703BH7SMF	5725-5875	3	150	38°	7 (17.8)	0.2 (0.1)	0.06 (0.006)	125 (200)	20	Polycarbonate	Ceiling	N/A
S5153BP5SMF	5150-5350	3	200	38°	7 (17.8)	0.2 (0.1)	0.06 (0.006)	125 (200)	20	Polycarbonate Tube End		2 (5.1)
S5153BH7SMF	5150-5350	3	200	38°	7 (17.8)	0.2 (0.1)	0.06 (0.006)	125 (200)	20	Polycarbonate	Ceiling	N/A
S5703M12NF	5725-5875	1	150	60°	1.5 (3.8)	0.4 (0.18)	0.02 (0.002)	125 (200)	20	Polycarbonate	Ceiling	N/A
S2406BP7NF	2400-2500	6	100	13°	25 (63.5)	0.5 (0.23)	0.11 (0.01)	125 (200)	20	Polycarbonate Tube End		2 (5.1)
S2406BH12NF	2400-2500	6	100	13°	25 (63.5)	0.5 (0.23)	0.11 (0.01)	80 (128)	20	Polycarbonate Tube End		N/A
S2403M12NF	2400-2500	1	100	60°	2 (5.1)	0.5 (0.23)	0.02 (0.002)	125 (200)	50	Polycarbonate	Ceiling	N/A
S2403BH12NF	2400-2500	3	100	38°	11.5 (29.2)	0.31 (0.14)	0.08 (0.007)	125 (200)	50	Polycarbonate	Ceiling	N/A
S2403BP12NF	2400-2500	3	100	38°	11.5 (29.2)	0.41 (0.18)	0.08 (0.007)	125 (200)	50	Polycarbonate Tube End		2 (5.1)
S2400BH12NF	2400-2500	0	100	75°	9 (22.9)	0.29 (0.13)	0.122 (0.011)	125 (200)	50	Polycarbonate	Ceiling	N/A
S1805BNF	1850-1990	5	140	16°	31 (78.7 x 2.5)	2 (0.9)	0.14 (0.013)	125 (200)	50	Polycarbonate	U- bolt & Bracket	N/A
S1803BNF	1850-1990	3	140	38°	13 (33.0 x 2.5)	1.3 (0.59)	0.06 (0.006)	125 (200)	50	Polycarbonate	Direct	N/A
S1800BNF	1850-1990	0	140	70°	8 (20.3)	1.2 (0.55)	0.04 (0.003)	125 (200)	50	Polycarbonate	Direct	N/A
S1715BNF	1710-1880	5	170	16°	33 (83)	2.2 (0.95)	0.15 (0.014)	125 (200)	50	Polycarbonate	Direct	N/A
S1713BNF	1710-1880	3	170	38°	14 (35.5)	1.4 (0.64)	0.07 (0.006)	125 (200)	50	Polycarbonate	Direct	N/A
S1710BNF	1710-1880	0	170	70°	9 (22.9)	1.3 (0.59)	0.04 (0.003)	125 (200)	50	Polycarbonate	Direct	N/A

Common specifications: VSWR - 1.5: nominal; Connector Type - N (female); Pigtail - 12 inch (30.5 cm); Element material - printed circuitradome diameter 1"

Americas: +1.847 839.6907
IAS-AmericasEastSales@lairdtech.com

Europe: +44.1628.858941
IAS-EUSales@lairdtech.com

Asia: +86.21.5855.0827.127
IAS-AsiaSales@lairdtech.com

www.lairdtech.com

ANT-DS-SPOMNI 0115

Any information furnished by Laird Inc. and its agents is believed to be accurate and reliable. All specifications are subject to change without notice. Responsibility for the use and application of Laird materials rests with the end user, since Laird and its agents cannot be aware of all potential uses. Laird makes no warranties as to the fitness, merchantability or suitability of any Laird materials or products for any specific or general uses. Laird shall not be liable for incidental or consequential damages of any kind. All Laird products are sold pursuant to the Laird Terms and Conditions of sale in effect from time to time, a copy of which will be furnished upon request. © Copyright 2015 Laird Inc. All Rights Reserved. Laird, Laird Technologies, the Laird Logo, and other marks are trade marks or registered trade marks of Laird Inc. or an affiliate company thereof. Other product or service names may be the property of third parties. Nothing herein provides a license under any Laird or any third party intellectual property rights.