



Chipsmall Limited consists of a professional team with an average of over 10 year of expertise in the distribution of electronic components. Based in Hongkong, we have already established firm and mutual-benefit business relationships with customers from,Europe,America and south Asia,supplying obsolete and hard-to-find components to meet their specific needs.

With the principle of “Quality Parts,Customers Priority,Honest Operation,and Considerate Service”,our business mainly focus on the distribution of electronic components. Line cards we deal with include Microchip,ALPS,ROHM,Xilinx,Pulse,ON,Everlight and Freescale. Main products comprise IC,Modules,Potentiometer,IC Socket,Relay,Connector.Our parts cover such applications as commercial,industrial, and automotives areas.

We are looking forward to setting up business relationship with you and hope to provide you with the best service and solution. Let us make a better world for our industry!



Contact us

Tel: +86-755-8981 8866 Fax: +86-755-8427 6832

Email & Skype: info@chipsmall.com Web: www.chipsmall.com

Address: A1208, Overseas Decoration Building, #122 Zhenhua RD., Futian, Shenzhen, China



CMOS 16-BIT SINGLE CHIP MICROCONTROLLER
S5U1C17W23T Manual
(Software Evaluation Tool for S1C17W22/W23)

Evaluation board/kit and Development tool important notice

1. This evaluation board/kit or development tool is designed for use for engineering evaluation, demonstration, or development purposes only. Do not use it for other purpose. It is not intended to meet the requirement of design for finished product.
2. This evaluation board/kit or development tool is intended for use by an electronics engineer, and it is not the product for consumer. The user should use this goods properly and safely. Seiko Epson dose not assume any responsibility and liability of any kind of damage and/or fire coursed by usage of it. User should cease to use it when any abnormal issue occurs even during proper and safe use.
3. The part used for this evaluation board/kit or development tool is changed without any notice.

NOTICE

No part of this material may be reproduced or duplicated in any form or by any means without the written permission of Seiko Epson. Seiko Epson reserves the right to make changes to this material without notice. Seiko Epson does not assume any liability of any kind arising out of any inaccuracies contained in this material or due to its application or use in any product or circuit and, further, there is no representation that this material is applicable to products requiring high level reliability, such as, medical products. Moreover, no license to any intellectual property rights is granted by implication or otherwise, and there is no representation or warranty that anything made in accordance with this material will be free from any patent or copyright infringement of a third party. When exporting the products or technology described in this material, you should comply with the applicable export control laws and regulations and follow the procedures required by such laws and regulations. You are requested not to use, to resell, to export and/or to otherwise dispose of the products (and any technical information furnished, if any) for the development and/or manufacture of weapon of mass destruction or for other military purposes.

All brands or product names mentioned herein are trademarks and/or registered trademarks of their respective companies.

Configuration of product number

● Devices

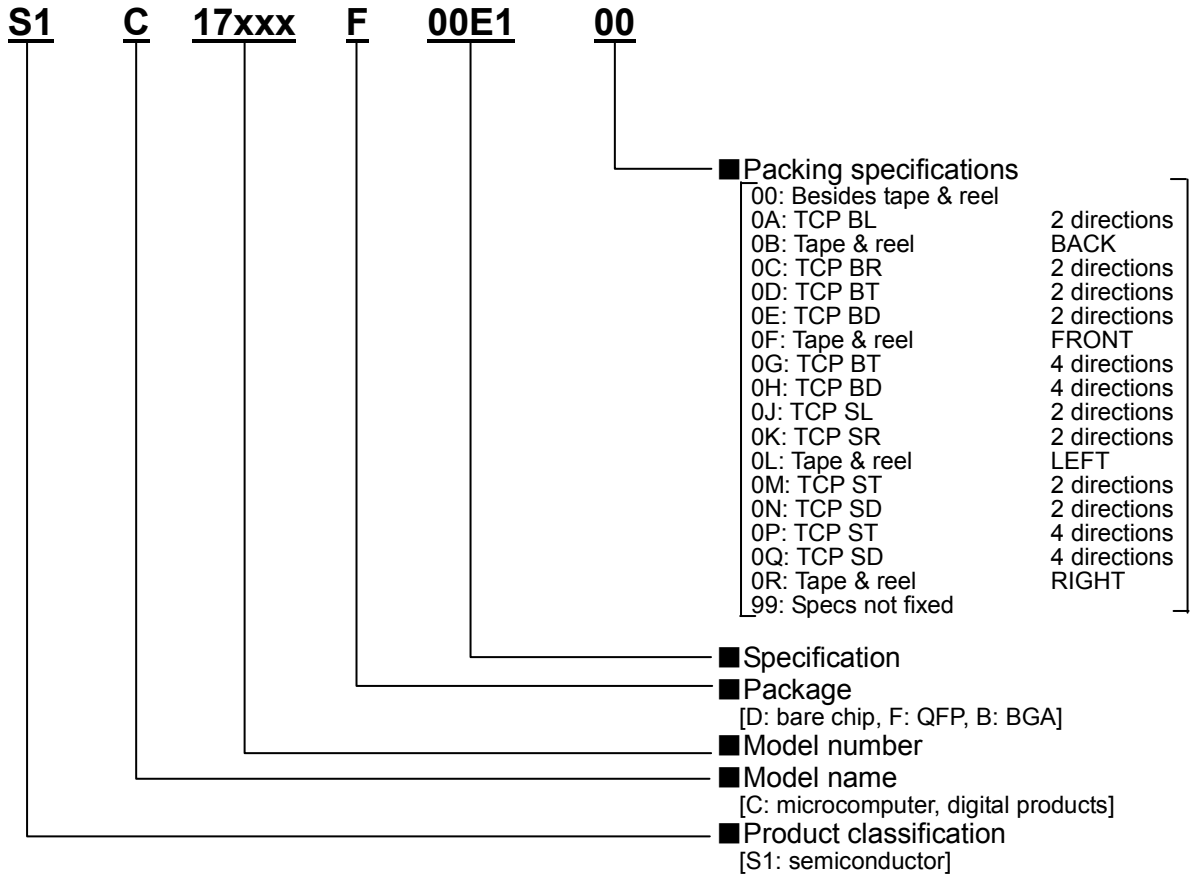

● Development tools

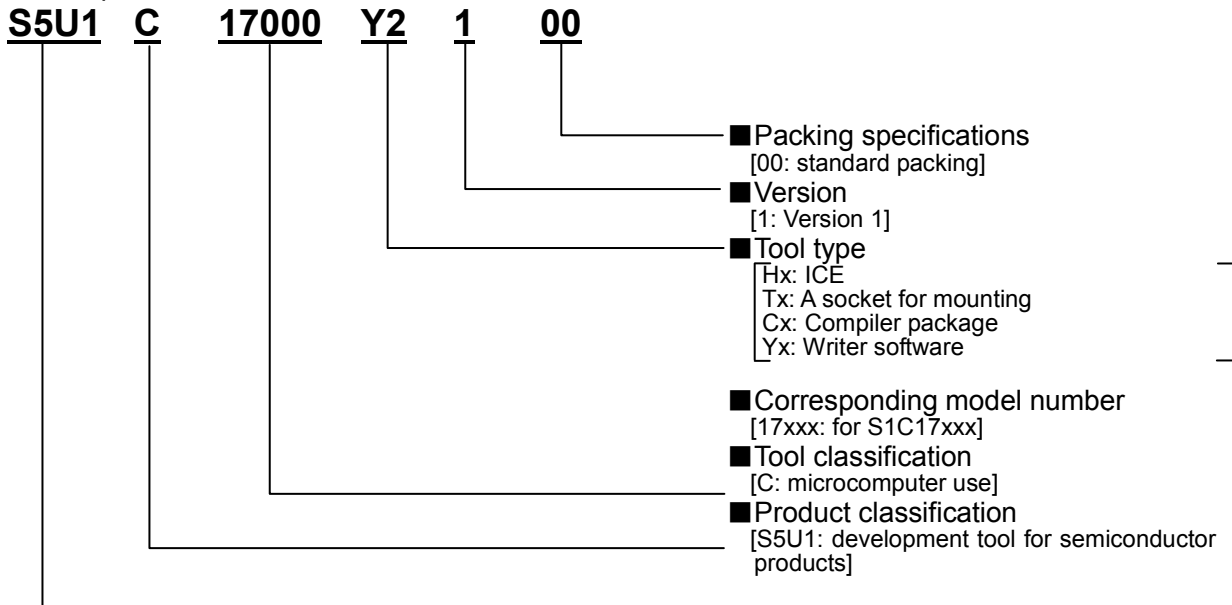

Table of Contents

1. Overview	1
1.1 Usage Methods	2
2. Name and Function of Each Part	4
2.1 Name of Each Part	4
2.2 Function of Each Part	6
2.2.1 Jumper Switch Functions	6
2.2.2 Function of Each Component	7
3. Block Diagram	8
4. Connectors	9
4.1 Extension Interface Connector (CN1)	9
4.2 Debug Interface Connectors (CN2-1 to CN2-2)	10
Appendix A Circuit Diagram and Component Table	11
Revision History	16

1. Overview

The SVT17W23 Software eValuation Tool for S1C17W23 (S5U1C17W23T) is a board for evaluating the S1C17W22/W23 single-chip microcontroller manufactured by Seiko Epson. This board incorporates the S1C17W23 microcontroller, an LCD panel, a tactile switch, a buzzer, debug interface connectors, and other components.

1) CPU	S1C17W23 (TQFP15-128pin)
2) Input power voltage	External power supply (DC 1.2 to 3.6V) Button battery (LR44: 1.5V) ^{*1}
3) CPU clock	OSC1 : 32.768kHz Crystal Oscillator OSC3 : Built-in electronic oscillator in the S1C17W23, or a ceramic resonator
4) Built-in devices	S1C17W23(16 Bit MCU) Crystal oscillator (32.768kHz) LCD panel (64seg × 16com) Piezoelectric buzzer Tactile switch Reset switch Jumper switch for selecting the operational power supply Jumper switch for measuring current consumption × 2 Debug interface connector × 2 Button battery holder
5) Operating temperature range	5°C to 35°C
6) Operating voltage range	1.2 V to 3.6 V

^{*1} Each component is not attached or incorporated.

Caution! Be careful not to expose this board to chlorinated solvents. Some components of the board may corrode or deteriorate, which could prevent the board from being used safely.

1. Overview

1.1 Usage Methods

Use the following procedures to debug the software for the S1C17W23 and create an evaluation environment.

< Debugging the software >

- (1) With the dedicated cable that comes bundled with the S5U1C17001H (ICDmini), connect the 4-pin connector for connecting the ICDmini target and the 4-pin connector for the power supply for writing to the flash memory to the CN2-1 (J5) and CN2-2 (J3) connectors, respectively, on this board.
- (2) Connect the jumper switch for selecting the operational power supply (JP5) to the “EXT” side.
- (3) Supply electric power from either the S5U1C17001H2 (ICDminiVer.2) or the stabilized power supply to the CN3 (J4) power supply connector header on this board. Ensure that the supplied power voltage is within the operational power supply voltage range for the S1C17W23. (This voltage range is between 1.8 V and 3.6 V when programming is performed on or data is written to the built-in flash memory in the S1C17W23.)
- (4) Connect the ICDmini and the PC with the USB cable that comes bundled with the ICDmini.

Set the SW4 and SW5 DIP switches (DSIO signal level selection) on the ICDmini so that the DSIO signal level is equal to the input voltage from the target. If you are using the S5U1C17001H2 (ICDminiVer.2) emulator and the voltage for erasing data from or performing programming on the flash memory is supplied from the ICDmini, set the SW8 DIP switch (selection of the voltage for programming the flash memory) to ON.

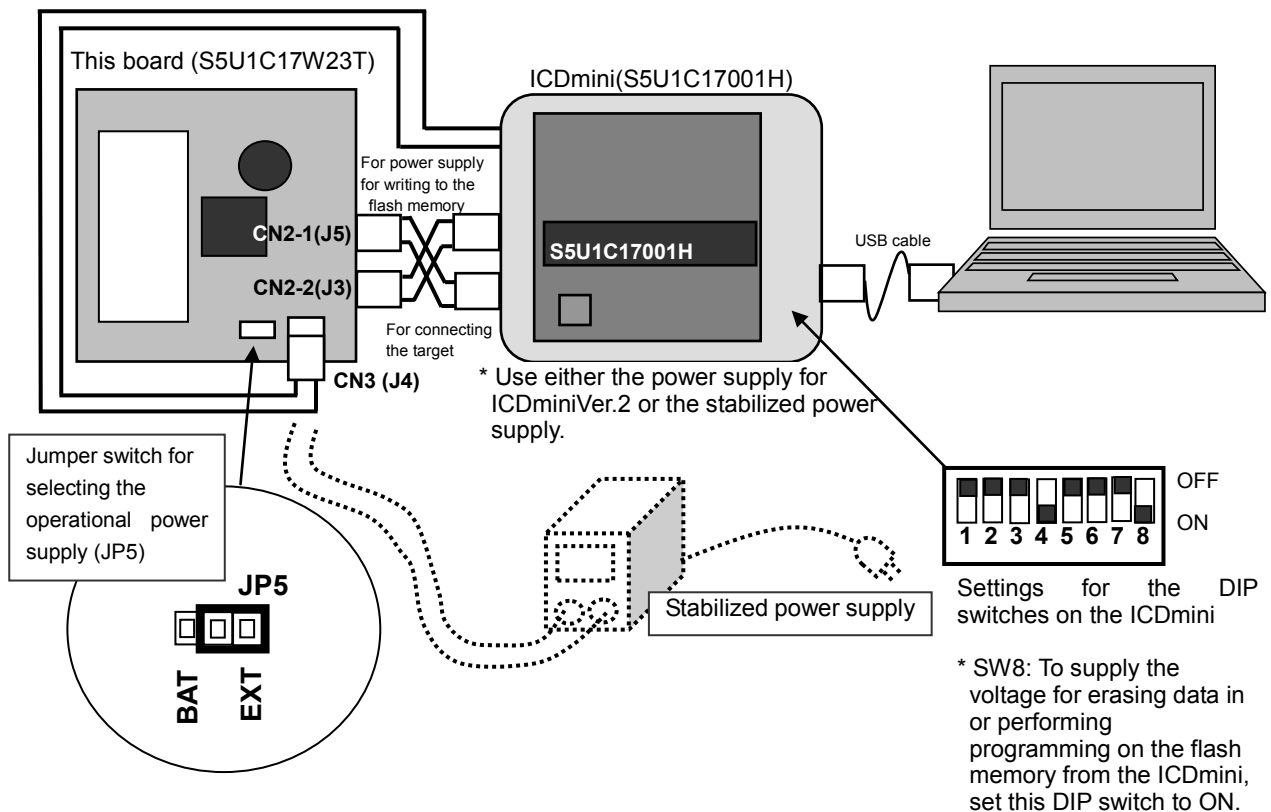

Figure 1.1 Connection method for debugging the software

< Performing a free run operation with an external power supply >

- (1) Connect the jumper switch for selecting the operational power supply (JP5) on this board to the “EXT” side.
- (2) Supply electric power from the stabilized power supply to the CN3 (J4) power supply connector header on this board. Ensure that the supplied power voltage is within the operational power supply voltage range for the S1C17W23.

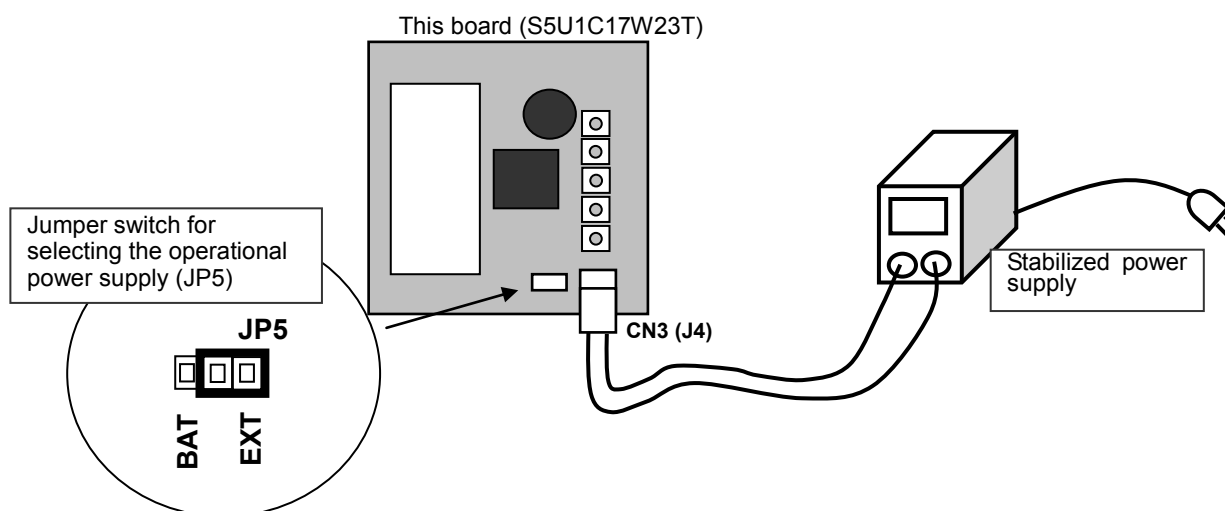

Figure 1.2 Connection method for performing a free run operation with an external power supply

< Performing a free run operation with a button battery >

- (1) Load an LR44 button battery in the battery holder on the back of this board.
- (2) Connect the jumper switch for selecting the operational power supply (JP5) on this board to the “BAT” side.
- (3) Press the “RESET” (SW5) switch on this board.

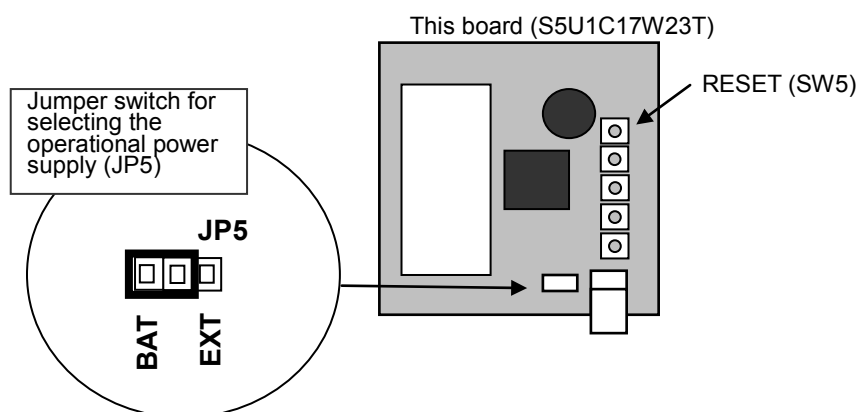

Figure 1.3 Setup method for performing a free run operation with a battery

2. Name and Function of Each Part

Table 1.1 List of jumper switch settings in each mode

Switch No.	Function	Debugging the software with an external power supply	Performing a free run operation with an external power supply	Performing a free run operation with a button battery
JP5	Operational power supply selection	EXT	EXT	BAT

2. Name and Function of Each Part

2.1 Name of Each Part

The following figures show the name and function of each part.

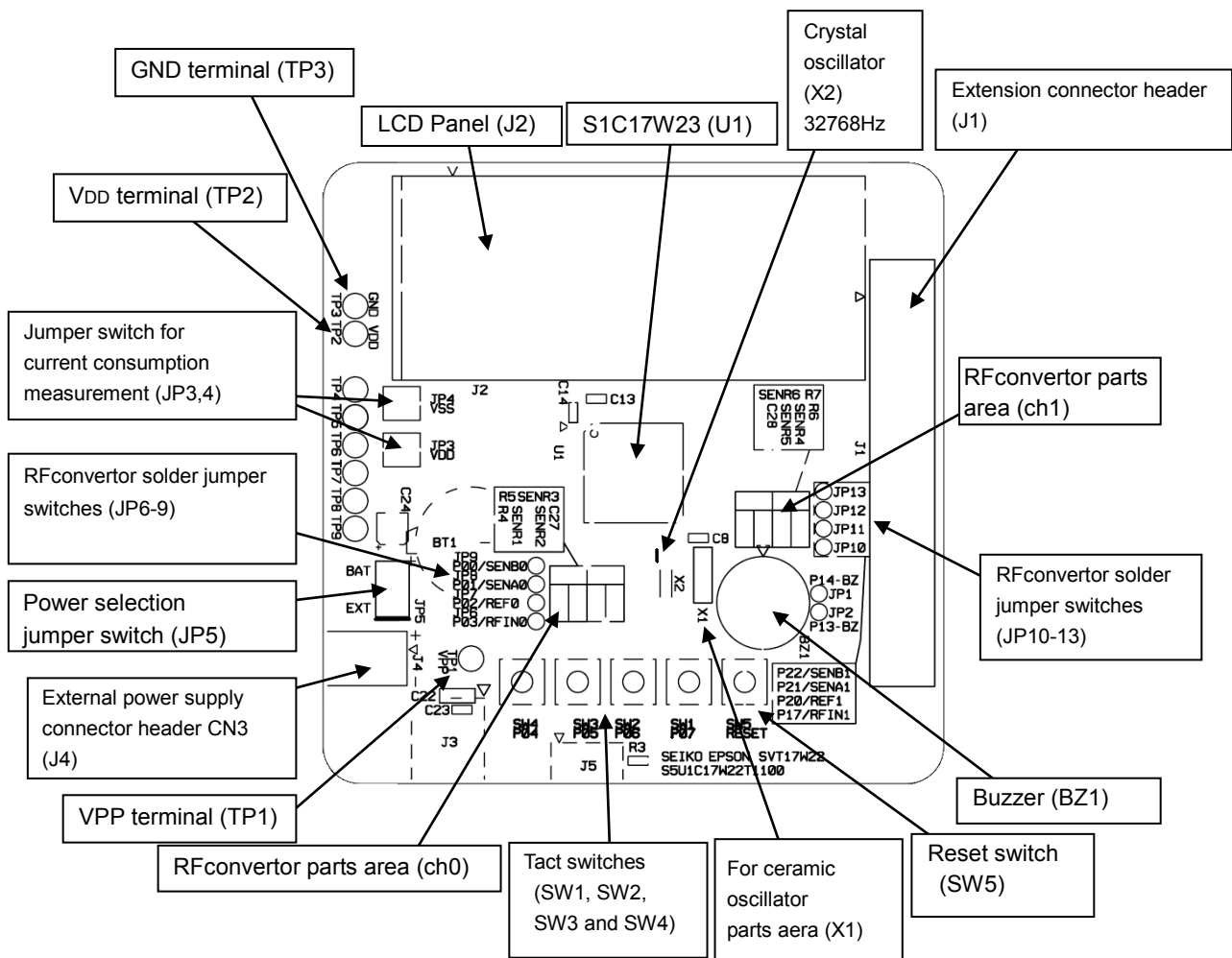

Figure 2.1 Name of each part on the front surface of the S5U1C17W23T

2. Name and Function of Each Part

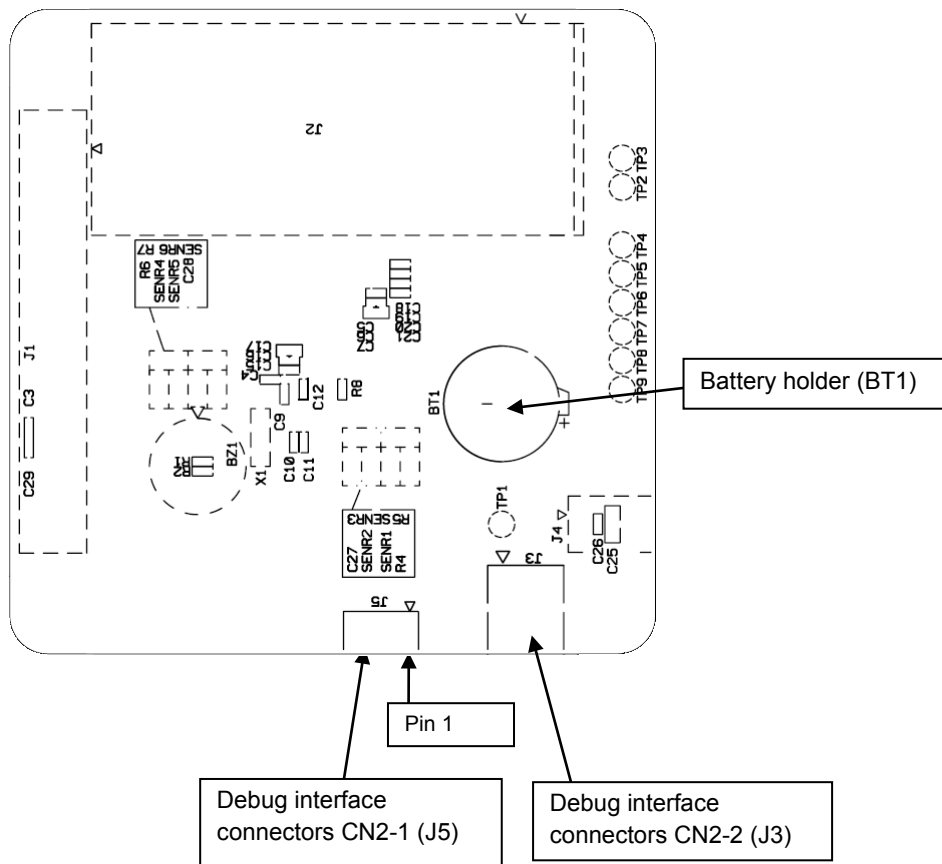

Figure 2.2 Name of each part on the back surface of the S5U1C17W23T

Caution! The position of pin 1 on the CN2-1(J5) connector is as shown above. Take due care of the connector orientation when connecting the ICDmini and this board.

2. Name and Function of Each Part

2.2 Function of Each Part

2.2.1 Jumper Switch Functions

Table 2.2.1 List of jumper switch functions

Name	Type	Function	Factory settings	Selectable settings
JP1	Soldering	Connecting the extension connector for port P14	Shorted	Open
JP2	Soldering	Connecting the extension connector for port P13	Shorted	Open
JP3	Pin	Measuring the current consumption for the S1C17W23 (V _{DD}) ^{*1}	Shorted	Open
JP4	Pin	Measuring the current consumption for the S1C17W23 (V _{SS}) ^{*1}	Shorted	Open
JP5	Pin	Selecting the operational power supply	BAT (battery)	EXT(external power supply)
JP6 to JP9	Soldering	Selecting the specifications for ports P00 to P03 ^{*2} RF converter (ch0), I/O port	Shorted (I/Oport)	Open (RFC)
JP10 to JP13	Soldering	Selecting the specifications for ports P17 to P22 ^{*2} RF converter (ch1), I/O port	Shorted (I/Oport)	Open (RFC)

*1 To measure the current consumption for the S1C17W23 alone, insert an ammeter between these jumper switches to measure the current.

*2 Remove solder when operating the RF converter by mounting a thermistor (or another resistor type) on this board.

2. Name and Function of Each Part

2.2.2 Function of Each Component

Table 2.2.2 List of the names and functions of components in each part

Component name	Location	Function
IC	U1	S1C17W23 (16-bit MCU)
Connector header	CN1(J1)	Extension interface connector header
Connector	CN2-1 to 2(J5,J3)	Debug interface connector (for connecting the S5U1C17001H)
Connector	CN3(J4)	External power supply connector
Switch	SW1,2,3,4	P07-P04 port input
Switch	SW5	Reset input
Monitor terminal	TP1(VPP)	Through-hole for VPP (the power supply for programming the flash memory)
Monitor terminal	TP2(VDD)	Through-hole for VDD
Monitor terminal	TP3(GND)	Through-hole mount for GND
Monitor terminal	TP4(VD1)	Through-hole for monitoring the DC-DC converter output voltage
Monitor terminal	TP5(VD2)	Through-hole for monitoring DC-DC converter voltage rise
Monitor terminal	TP6-TP9(VC1-VC4)	Through-hole for monitoring LCD voltage rise
Capacitor	C27	Reference capacity (DC/AC bias, channel 0)
Resistor	R4	Reference resistance (DC bias, channel 0)
Sensor	SENR1	Resistive sensor 1 (DC bias, channel 0)
Sensor	SENR2	Resistive sensor 2 (DC bias, channel 0)
Resistor	R5	Reference resistance (AC bias, channel 0)
Resistive sensor	SENR3	Resistive sensor (AC bias, channel 0)
Capacitor	C28	Reference capacity (DC/AC bias, channel 1)
Resistor	R6	Reference resistance (DC bias, channel 1)
Sensor	SENR4	Resistive sensor 1 (DC bias, channel 1)
Sensor	SENR5	Resistive sensor 2 (DC bias, channel 1)
Resistor	R7	Not use
Resistive sensor	SENR6	Not use
Battery holder	BT1	Button battery holder
LCD	LCD(J2)	64seg x 16com, 1/4 bias, 1/16 duty

3. Block Diagram

3. Block Diagram

A block diagram for the S5U1C17W23T1 is shown below.

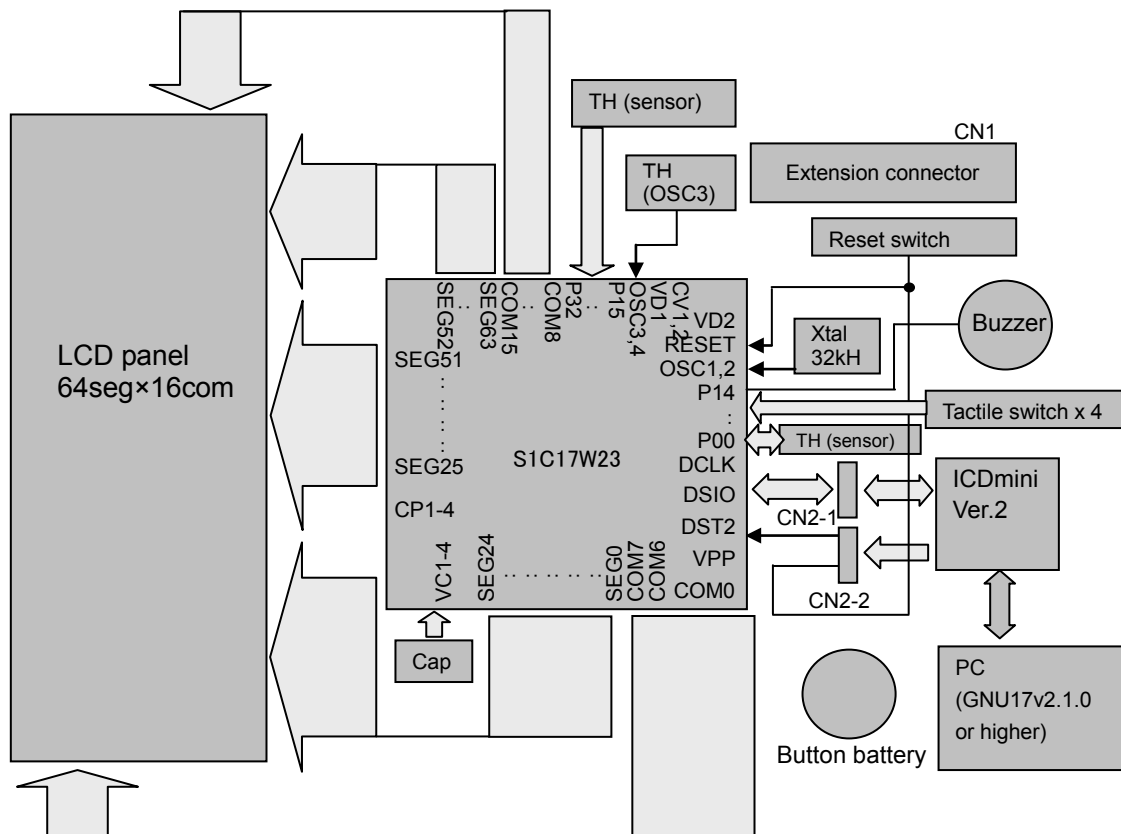

Caution! No temperature/humidity sensor or OSC3 oscillator is provided. Only through-holes are provided.

Figure 3.1 Block diagram for the S5U1C17W23T1

4. Connectors

4.1 Extension Interface Connector (CN1(J1))

Table 4.1 Pin layout for extension interface connector CN1

No.	Pin name	I/O	Function	No.	Pin name	I/O	Function
1	P44	I/O	P44/EXCL01/SEG54	21	P21	I/O	P21/UPMUX/SENA1
2	P43	I/O	P43/EXCL00/SEG55	22	P20	I/O	P20/UPMUX/REF1
3	P42	I/O	P42/LFRO/SEG56 /COM23/COM15	23	#RESET	I	System reset input
4	P41	I/O	P41/EFCLK01/SEG57 /COM22/COM14	24	P17	I/O	P17/UPMUX/RFIN1
5	P40	I/O	P40/RFCLK00/SEG58 /COM21/COM13	25	P16	I/O	P16/REMO/UPMUX/EXSVD
6	V _{SS}	—	Power supply (GND)	26	P15	I/O	P15/FOUT/UPMUX
7	P37	I/O	P37/UPMUX/SEG59 /COM20/COM12	27	P14	I/O	P14/BZOUT/UPMUX
8	P36	I/O	P36/UPMUX/SEG60 /COM19/COM11	28	P13	I/O	P13/#BZOUT/UPMUX/OPIN1P /VREFA
9	P35	I/O	P35/UPMUX/SEG61 /COM18/COM10	29	P12	I/O	P12/UPMUX/OPIN1N/ADIN0
10	P34	I/O	P34/UPMUX/SEG62 /COM17/COM9	30	P11	I/O	P11/UPMUX/OPOUT1/ADIN1
11	P33	I/O	P33/UPMUX/SEG63 /COM16/COM8	31	P10	I/O	P10/UPMUX/OPOUT0/ADIN2
12	P32	I/O	P32/UPMUX/SEG64 /COM15/COM7	32	V _{DD}	—	Power supply (+)
13	P31	I/O	P31/EXCL21/UPMUX/SEG65 /COM14/COM6	33	P07	I/O	P07/UPMUX/OPIN0N/ADIN3
14	P30	I/O	P30/EXCL20/UPMUX/SEG66 /COM13/COM5	34	P06	I/O	P06/UPMUX/OPIN0P/ADIN4
15	P27	I/O	P27/EXCL11/UPMUX /SEG67/COM12/COM4	35	P05	I/O	P05/UPMUX/ADIN5
16	P26	I/O	P26/EXCL10/UPMUX /SEG68/COM11/COM3	36	P04	I/O	P04/RTC1S/UPMUX
17	P25	I/O	P25/#ADTRG/UPMUX/SEG69 /COM10/COM2	37	P03	I/O	P03/UPMUX/RFIN0
18	P24	I/O	P24/UPMUX/SEG70 /COM9/COM1	38	P02	I/O	P02/UPMUX/REF0
19	P23	I/O	P23/UPMUX/SEG71 /COM8/COM0	39	P01	I/O	P01/UPMUX/SENA0
20	P22	I/O	P22/UPMUX/SENB1	40	P00	I/O	P00/UPMUX/SENB0

4. Connectors

4.2 Debug Interface Connectors (CN2-1(J5) to CN2-2(J3))

Table 4.2 Pin layout for debug interface connector CN2-1

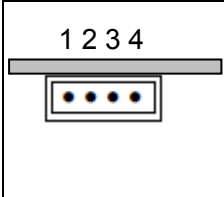
Board		No.	Pin name	I/O	Function
→	1 2 3 4	1	DCLK	O	Clock signal for debugging
		2	GND	—	Power supply (GND)
		3	DSIO	I/O	Serial communication I/O signal for debugging
		4	DST2	O	Debug status signal

Caution! Take due care of the connector orientation when connecting the ICDmini and this board.

Table 4.3 Pin layout for debug interface connector CN2-2

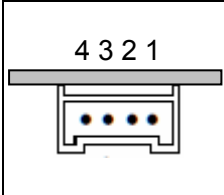
Board		No.	Pin name	I/O	Function
→	4 3 2 1	1	VPP	I	Power input for programming the flash memory
		2	GND	—	Power supply (GND)
		3	RESET	I	Target reset signal input
		4	VCCIN	O	Target voltage output

Appendix A Circuit Diagram and Component Table

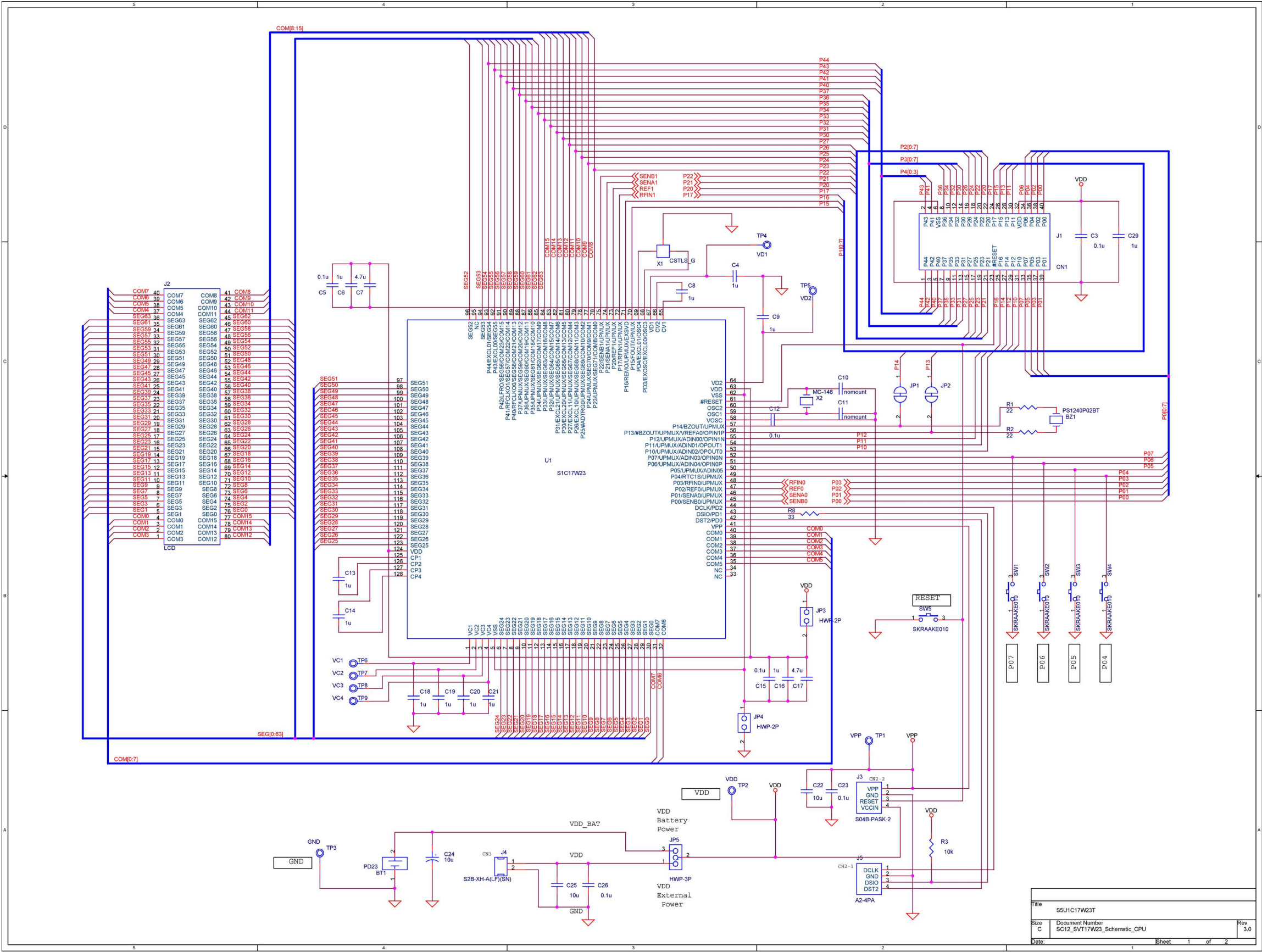

Title	S5U1C17W23T	
Size	Document Number	Rev
c	SC12_SVT17W23_Schematic_CPU	3.0
Date:	Sheet	1 of 2

Appendix A Circuit Diagram and Component Table

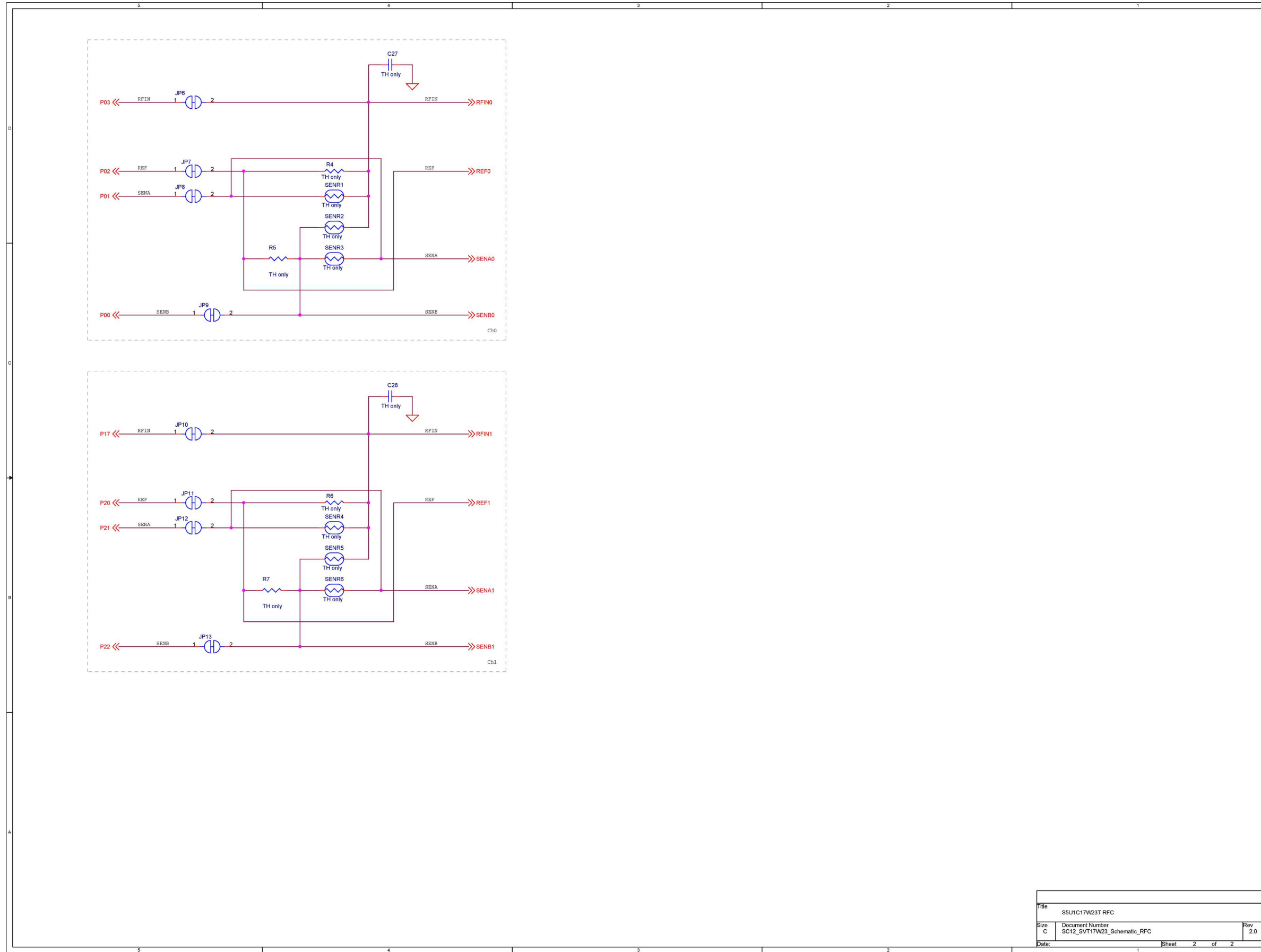

File		
SSU1C17W23T RFC		
Size	Document Number	Rev
C	SC12_SVT17W23_Schematic_RFC	2.0
Date:	Sheet 2 of 2	

Appendix A Circuit Diagram and Component Table

LCD panel wiring diagram

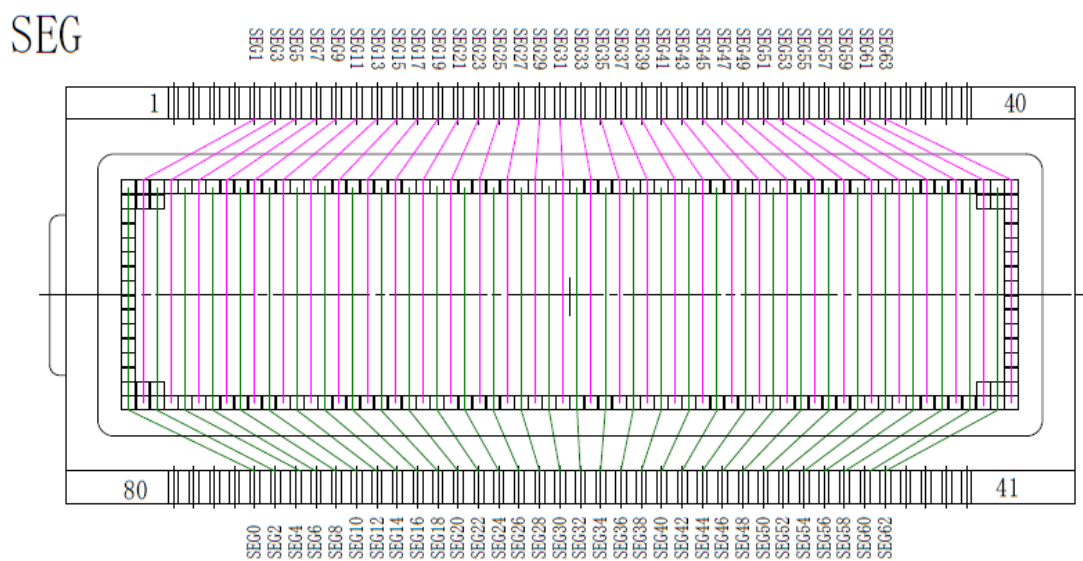
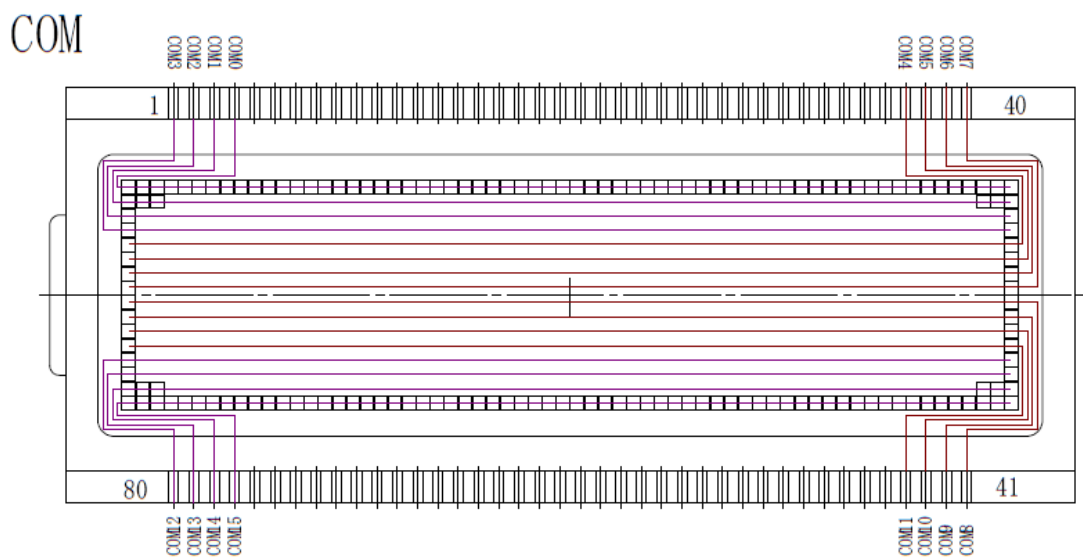

LCD panel specifications

Voltage	Duty	Bias	Frame frequency
4.5V	1/16	1/4	64Hz

Appendix A Circuit Diagram and Component Table

S5U1C17W23T1100 component table*1

No.	Location	Name	Model number	Specifications	Qty	Manufacturer
1	BT1	Button battery holder	PD23	LR44	1	TAKACHI ELECTRONICS ENCLOSURE CO., LTD.
2	BZ1	Piezoelectric buzzer	PS1240P02BT	Φ=12.2mm	1	TDK Corporation
3	C3,C12,C15,C23,C26	Ceramic capacitor	C1608X5R1H104M	0.1uF/50V/1608/X5R	6	TDK Corporation
4	C5		Unmounted	1608	0	
5	C4,C8,C9,C13,C14,C16,C18,C19,C20,C21,C29	Ceramic capacitor	C1608X5R1H105K	1uF/50V/1608/X5R	12	TDK Corporation
6	C6		Unmounted	1608	0	
7	C17	Ceramic capacitor	C2012X5R1H475K	4.7uF/50V/2012/X5R	2	TDK Corporation
8	C7		Unmounted	1608	0	
9	C11,C10	Ceramic capacitor	Unmounted	1608	0	
10	C22,C25	Ceramic capacitor	C2012X5R1E106K	10uF/25V/2012/X5R	2	TDK Corporation
11	C24	Electrolytic capacitor	EEE1EA100WR	10uF/25V	1	Panasonic Corporation
12	SENR1,SENR2,SENR3,SENR4,R4,SENR5,R5,SENR6,R6,R7,C27,C28	Sensor, resistor, capacity	Unmounted	Φ =1.0 mm or less, 2.54 mm pitch	0	
13	JP4,JP3	Jumper pin	HWP-2P-G	2pin, SMT	2	Mac-Eight Co.,Ltd.
14	JP5	Jumper pin	HWP-3P-G	3pin, SMT	1	Mac-Eight Co.,Ltd.
15	J1	Connector	Unmounted	Φ=1.0mm or less, 2.54mmpitch	0	
16	J2	LCD panel	EPSON64X16DOTS	64seg×16com,1/16 duty, 1/4bias	1	
17	J3	Connector	S04B-PASK-2	4pin	1	J.S.T. Mfg.Co.,Ltd.
18	J4	Connector	Unmounted	2pin	0	
19	J5	Connector	A2-4PA-2.54DS(71)	4pin	1	HIROSE ELECTRIC CO.,LTD.
20	R1,R2	Resistor	MCR03EZPJ220	22Ω/1608	2	ROHM Co., Ltd
21	R3	Resistor	MCR03EZPJ103	10kΩ/1608	1	ROHM Co., Ltd
22	R8	Resistor	MCR03EZPJ330	33Ω/1608	1	ROHM Co., Ltd
23	SW1,SW2,SW3,SW4,SW5	Tactile switch	SKRAAKE010	SMT	5	ALPS ELECTRIC CO., LTD.

Appendix A Circuit Diagram and Component Table

No.	Location	Name	Model number	Specifications	Qty	Manufacturer
21	TP1	VPP terminal	Unmounted	Φ=1.0 mm or less	0	
22	TP2	VDD terminal	Unmounted	Φ =1.0 mm or less	0	
23	TP3	GND terminal	Unmounted	Φ=1.0 mm or less	0	
24	TP4-TP9	Terminal	Unmounted	Φ =1.0 mm or less	0	
25	U1	MCU	S1C17W23	16bitMCU	1	SEIKO EPSON Corp.
26	X2	Crystal oscillator	MC-146	32.768kHz, CL=9pF	1	SEIKO EPSON Corp.
27	X1	Ceramic resonator	Unmounted	3 terminals, 2.54 mm pitch	0	

*1 Each component may be subject to change without prior notice.

S5U1C17W23T1100 component table (attachments, accessories)*1

No.	Location	Name	Model number	Specifications	Qty	Manufacturer
1	Incorporated	Jumper switch	JS-1		3	Mac-Eight Co.,Ltd.
2	Incorporated	Screw	FB-0305N	M=3, L=5mm	4	Wilco.
3	Incorporated	Spacer	ASB-309.5E	M=3, L=9.5mm	4	HIROSUGI-KEIKI Co., Ltd.

*1 Each component may be subject to change without prior notice.

AMERICA

EPSON ELECTRONICS AMERICA, INC.

214 Devcon Drive,
San Jose, CA 95112, USA
Phone: +1-800-228-3964 FAX: +1-408-922-0238

EUROPE

EPSON EUROPE ELECTRONICS GmbH

Riesstrasse 15, 80992 Munich,
GERMANY
Phone: +49-89-14005-0 FAX: +49-89-14005-110

ASIA

EPSON (CHINA) CO., LTD.

7F, Jinbao Bldg., No.89 Jinbao St.,
Dongcheng District,
Beijing 100005, CHINA
Phone: +86-10-8522-1199 FAX: +86-10-8522-1125

SHANGHAI BRANCH

7F, Block B, Hi-Tech Bldg., 900 Yishan Road,
Shanghai 200233, CHINA
Phone: +86-21-5423-5577 FAX: +86-21-5423-4677

SHENZHEN BRANCH

12F, Dawning Mansion, Keji South 12th Road,
Hi-Tech Park, Shenzhen 518057, CHINA
Phone: +86-755-2699-3828 FAX: +86-755-2699-3838

EPSON HONG KONG LTD.

Unit 715-723, 7/F Trade Square, 681 Cheung Sha Wan Road,
Kowloon, Hong Kong.
Phone: +852-2585-4600 FAX: +852-2827-4346

EPSON TAIWAN TECHNOLOGY & TRADING LTD.

14F, No. 7, Song Ren Road,
Taipei 110, TAIWAN
Phone: +886-2-8786-6688 FAX: +886-2-8786-6660

EPSON SINGAPORE PTE., LTD.

1 HarbourFront Place,
#03-02 HarbourFront Tower One, Singapore 098633
Phone: +65-6586-5500 FAX: +65-6271-3182

SEIKO EPSON CORP.**KOREA OFFICE**

5F, KLI 63 Bldg., 60 Yoido-dong,
Youngdeungpo-Ku, Seoul 150-763, KOREA
Phone: +82-2-784-6027 FAX: +82-2-767-3677

SEIKO EPSON CORP.**MICRODEVICES OPERATIONS DIVISION****Device Sales & Marketing Department**

421-8, Hino, Hino-shi, Tokyo 191-8501, JAPAN
Phone: +81-42-587-5814 FAX: +81-42-587-5117