



Chipsmall Limited consists of a professional team with an average of over 10 year of expertise in the distribution of electronic components. Based in Hongkong, we have already established firm and mutual-benefit business relationships with customers from,Europe,America and south Asia,supplying obsolete and hard-to-find components to meet their specific needs.

With the principle of "Quality Parts,Customers Priority,Honest Operation,and Considerate Service",our business mainly focus on the distribution of electronic components. Line cards we deal with include Microchip,ALPS,ROHM,Xilinx,Pulse,ON,Everlight and Freescale. Main products comprise IC,Modules,Potentiometer,IC Socket,Relay,Connector.Our parts cover such applications as commercial,industrial, and automotives areas.

We are looking forward to setting up business relationship with you and hope to provide you with the best service and solution. Let us make a better world for our industry!



## Contact us

Tel: +86-755-8981 8866 Fax: +86-755-8427 6832

Email & Skype: info@chipsmall.com Web: www.chipsmall.com

Address: A1208, Overseas Decoration Building, #122 Zhenhua RD., Futian, Shenzhen, China



**Intelligent Network Controller for Embedded Systems**

**S1S60000**

**Evaluation Board Technical Manual  
(S5U1S60K00H0400)**



## NOTICE

---

No part of this material may be reproduced or duplicated in any form or by any means without the written permission of Seiko Epson. Seiko Epson reserves the right to make changes to this material without notice. Seiko Epson does not assume any liability of any kind arising out of any inaccuracies contained in this material or due to its application or use in any product or circuit and, further, there is no representation that this material is applicable to products requiring high level reliability, such as, medical products. Moreover, no license to any intellectual property rights is granted by implication or otherwise, and there is no representation or warranty that anything made in accordance with this material will be free from any patent or copyright infringement of a third party. This material or portions thereof may contain technology or the subject relating to strategic products under the control of the Foreign Exchange and Foreign Trade Law of Japan and may require an export license from the Ministry of International Trade and Industry or other approval from another government agency. All other product names mentioned herein are trademarks and/or registered trademarks of their respective companies.



# Product Model Number System

## ●DEVICES

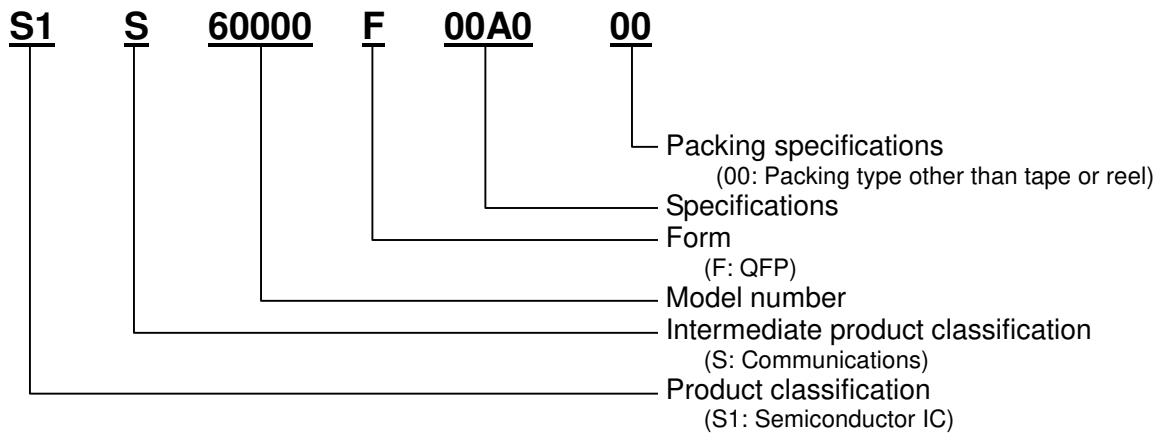

## ●Development Tools

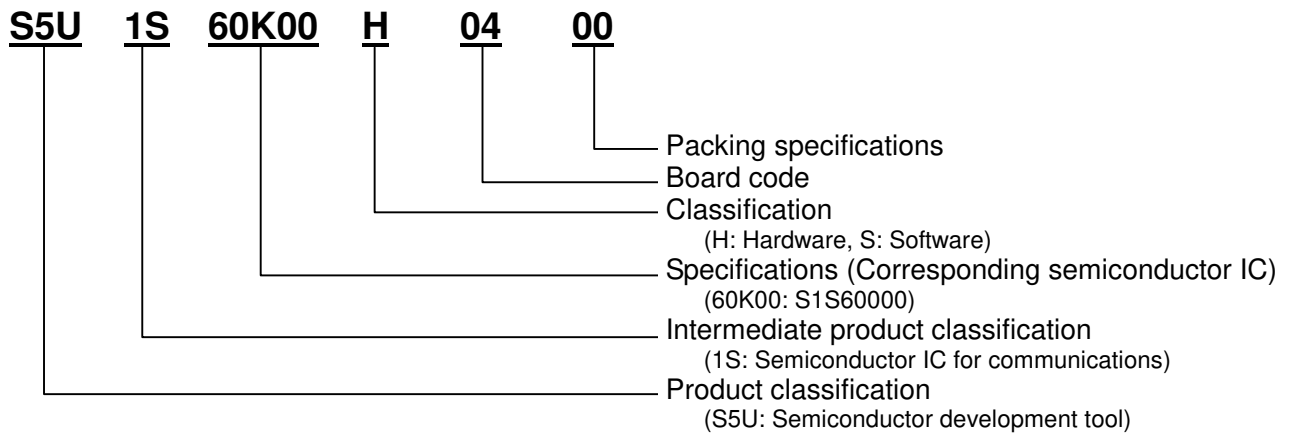



## CONTENTS

<b>1. Overview .....</b>	<b>1</b>
<b>2. Components .....</b>	<b>1</b>
<b>3. Overall Block Diagram.....</b>	<b>1</b>
<b>4. Mechanical Specifications .....</b>	<b>2</b>
<b>5. External Pins .....</b>	<b>3</b>
5.1 Interface connector layout.....	3
5.2 Power supply connector (CN6) .....	3
5.3 Host interface connector (CN1).....	3
5.4 Serial interface connector (CN3).....	3
5.5 General-purpose connector (GPIO 0-15).....	3
5.6 Ethernet connector (CN2) .....	3
<b>6. Mode Selector Switches .....</b>	<b>4</b>
6.1 Host interface type setting DIP switch (SW1).....	4
6.2 Reset switch (SW2).....	4
<b>7. Jumpers .....</b>	<b>4</b>
7.1 External board power supply jumper (J3).....	4
<b>8. Mounted Devices .....</b>	<b>5</b>
8.1 Ethernet Physical Layer (PHY) .....	5
8.2 E <sup>2</sup> PROM (3-wire connection) .....	5
8.3 RS232C driver IC (UART connection).....	6
<b>9. Power Supply .....</b>	<b>7</b>
<b>10. Verifying Operation.....</b>	<b>7</b>
<b>Appendix 1: Circuit Diagrams.....</b>	<b>8</b>
<b>Revision History .....</b>	<b>11</b>





## 1. OVERVIEW

This product, the S1S60000 Evaluation Board Kit, is an evaluation board for the Seiko Epson S1S60000 network controller chip and includes an Ethernet physical layer IC (PHY), an RS232C driver IC, E<sup>2</sup>PROM, and the required interface connectors.

## 2. COMPONENTS

<b>Network controller IC:</b>	S1S60000
<b>E<sup>2</sup>PROM:</b>	Three-wire E2PROM (SII S-93C46BR01-J8V1G)
<b>Ethernet block:</b>	MII connection 10/100BaseT Built-in transformer RJ45 connector (J0011D21B) ↔ KSZ8721BL
<b>Serial interface:</b>	An RS232C driver IC and a D-sub connector are provided
<b>Host interface:</b>	A 50-pin connector is provided
<b>Power supply voltage:</b>	Supplied from a 5 V jack

## 3. OVERALL BLOCK DIAGRAM

Figure 3-1 shows the block diagram for this evaluation board.

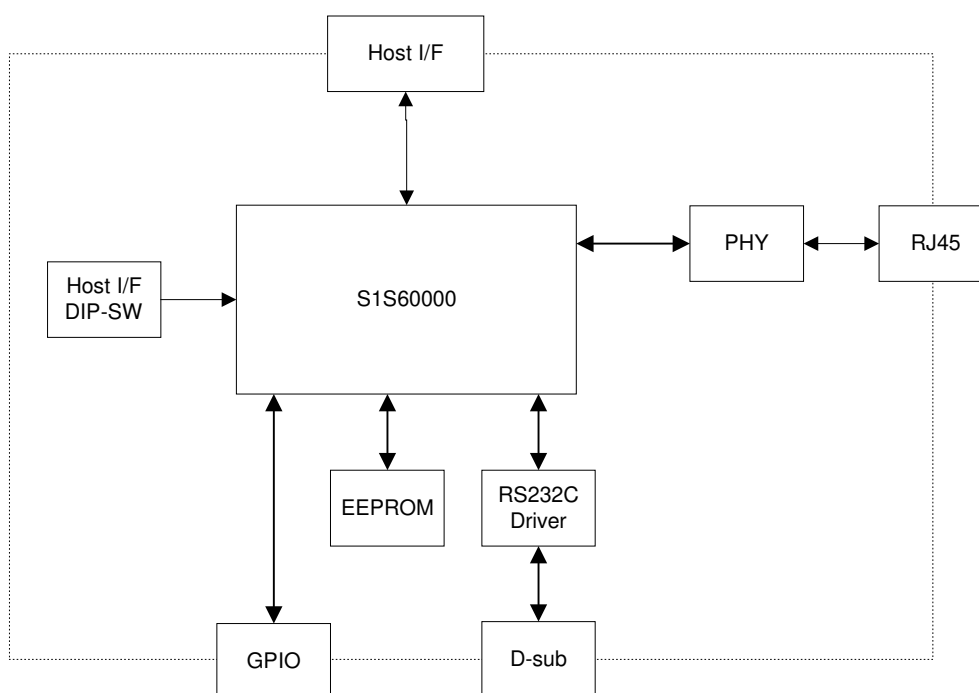

Figure 3-1

## 4. MECHANICAL SPECIFICATIONS

Figure 4-1 shows the dimensional drawing for this evaluation board.

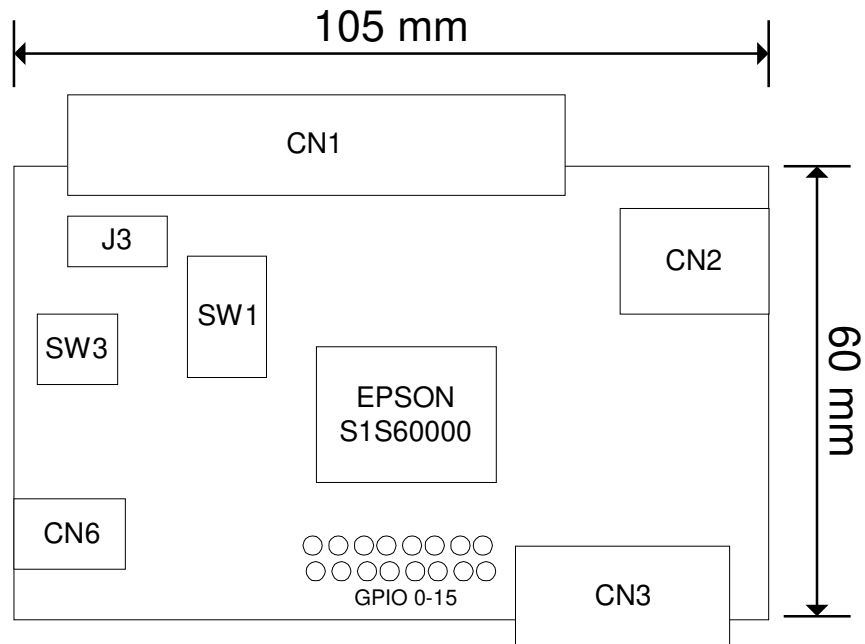

Figure 4-1

## 5. EXTERNAL PINS

### 5.1 Interface connector layout

See figure 4-1 for the locations of the external interface connectors (CN) provided by this evaluation board.

### 5.2 Power supply connector (CN6)

The 5 V power supply is provided to the DC jack, CN6. AC/DC adapters with a plug inner diameter of 2.1 mm and an outer diameter of 5.5 mm can be used as the DC plug.

### 5.3 Host interface connector (CN1)

The 3M 2550-5002 or equivalent connector is used.

Pin	Signal Name	Pin	Signal Name	Pin	Signal Name	Pin	Signal Name
1	Reserved	14	GND	27	HD14	40	HD5
2	Reserved	15	Reserved	28	HD15	41	HD2
3	Reserved	16	Reserved	29	HD12	42	HD3
4	Reserved	17	Reserved	30	HD13	43	GND
5	3.3V	18	Reserved	31	HD10	44	GND
6	3.3V	19	Reserved	32	HD11	45	HD0
7	Reserved	20	HINT	33	GND	46	HD1
8	Reserved	21	HRD0#	34	GND	47	HA2
9	GND	22	HRD1#	35	HD8	48	HCS#
10	GND	23	GND	36	HD9	49	HA0
11	Reserved	24	GND	37	HD6	50	HA1
12	Reserved	25	HWR0#	38	HD7	—	—
13	GND	26	HWR1#	39	HD4	—	—

### 5.4 Serial interface connector (CN3)

The JAE DELC-J9PAF-10L9E or equivalent D-sub is used. The S1S60000's UART signals are connected through the RS232C driver IC.

Pin	Signal Name	Pin	Signal Name
1	DCD (Unused)	6	DSR
2	RXD	7	RTS (Unused)
3	TXD	8	CTS
4	DTR (Unused)	9	RI (Unused)
5	GND	10	—

### 5.5 General-purpose connector (GPIO 0-15)

This connector has 2.54 mm pitch through holes. It is used to connect the S1S60000's GPIO0-15 signals.

### 5.6 Ethernet connector (CN2)

The Pulse Engineering Inc. J0011D21B or equivalent connector is used. This connector includes a built-in pulse transformer.

Pin	Signal Name	Pin	Signal Name
1	TXP	5	Reserved (*1)
2	TXN	6	RXN
3	RXP	7	Reserved (*1)
4	Reserved (*1)	8	Reserved (*1)

\*1: This pin is connected internally in the connector. See the connector specifications for details.

## 6. MODE SELECTOR SWITCHES

See figure 4-1 for the position of the mode selector switches provided by this evaluation board.

### 6.1 Host interface type setting DIP switch (SW1)

This switch is provided to set the board to match the host CPU connected to the S1S60000. When this switch is set to ON, 0 is input to the S1S60000, and when set to OFF, 1 is input. See section 13, Host Interface (HIF) in the S1S60000 Technical Manual for details on the host interface.

SW	Host Interface Signal Name	Function	Description
1	HIFSEL0	Host interface type setting	3 : 2 : 1 ON : ON : ON Type0 SH-3/4 ON : ON : OFF Type1 MC68000 ON : OFF : ON Type2 MC68030, MC68040 ON : OFF : OFF Type3 Generic OFF : ON : ON Reserved OFF : ON : OFF Type5 MIPS, ISA OFF : OFF : ON Type6 PCMCIA OFF : OFF : OFF Reserved
2	HIFSEL1		
3	HIFSEL2		
4	HMUX	Multiplexed bus setting	ON : Multiplex Bus OFF : Separate Bus
5	HINTPOL	Interrupt signal polarity	ON : Low Active OFF : High Active
6	HENDIAN	Endian setting	ON : Little endian OFF : Big endian
7	HSIZE	Bus width setting	ON : 16-bit bus OFF : 8-bit bus
8	SERIAL MODE	Serial mode	ON : Serial to Ethernet conversion OFF : Hardware control

### 6.2 Reset switch (SW2)

This switch outputs a reset pulse and inputs a reset signal to the ICs on this board.

## 7. JUMPERS

### 7.1 External board power supply jumper (J3)

When J1 is connected, pins 5 and 6 in the CN1 connector will be connected to the 3.3 V power supply.

## 8. MOUNTED DEVICES

### 8.1 Ethernet Physical Layer (PHY)

The Micrel KSZ8721BL (with Auto MDIX support) is used. It is connected to the S1S60000's MII.

### 8.2 E<sup>2</sup>PROM (3-wire connection)

The SII S-93C46BR01-J8V1G or equivalent product is used.

The data words stored in the E<sup>2</sup>PROM are all 16 bits in length. The table below presents the data map when the evaluation board is shipped. The data at indices 01h to 27h are loaded into the S1S60000's internal registers after a reset.

Index	Data	Value	Description
00h	ID	E0C3h	Fixed value: 0xE0C3
01h	MAC0	0000h	The customer must acquire a unique MAC address to set the IC to. Set these locations to a usable address after acquiring this product.
02h	MAC1	0000h	
03h	MAC2	0000h	
04h	GENCR	0310h	Setting value for the GENCR register
05h	HIFCR	0700h	Setting value for the HIFCR register
06h	I2CSADR	0030h	Setting value for the I2CSADR register
07h	I2CCONF	0235h	Setting value for the I2CCONF register
08h	GPALT	FF84h	Setting value for the GPALT register
09h	GPCFG	0000h	Setting value for the GPCFG register
0Ah	GPDAT	0000h	Setting value for the GPDAT register
0Bh	GPMSK	0000h	Setting value for the GPMSK register
0Ch	EPMSK	0000h	Setting value for the EPMSK register
0Dh	I2CMSK	0000h	Setting value for the I2CMSK register
0Eh	PMWAIT	000Fh	Setting value for the PMWAIT register
0Fh	PHYMODE	0200h	Setting value for the PHYMODE register
10h	ANEGR	10EFh	Setting value for the ANEGR register
11h	IPADRH	A8C0h	IP address: The initial value of the local IP address - 192.168.0.254
12h	IPADRL	FE00h	
13h	SNMSKH	FFFFh	Subnet mask: The initial value of the subnet mask - 255.255.255.0
14h	SNMSKL	00FFh	
15h	DGWH	A8C0h	Default gateway: The initial value of the default gateway: 192.168.0.1
16h	DGWL	0100h	
17h	DADR0H	A8C0h	Destination IP address 0: 192.168.0.2
18h	DADR0L	0200h	
19h	DADR1H	A8C0h	Destination IP address 1: 192.168.0.3
1Ah	DADR1L	0300h	
1Bh	DADR2H	A8C0h	Destination IP address 2: 192.168.0.4
1Ch	DADR2L	0400h	
1Dh	DADR3H	A8C0h	Destination IP address 3: 192.168.0.5
1Eh	DADR3L	0500h	
1Fh	PORT	00C0h	Setting value for the PORT register
20h	DPORT	01C0h	Setting value for the DPORT register
21h	SERMODE	00E1h	Setting value for the SERMODE register
22h	TMOUT	4000h	Setting value for the TMOUT register
23h	SOPAR	0070h	Setting value for the SOPAR register
24h	COMN0	7570h	Setting value for the COMN0, COMN1, COMN2, and COMN3 registers. These hold the community name that the SNMP agent can be set to. The default community name for the SNMP agent is "public", regardless of the internal registers.
25h	COMN1	6C62h	
26h	COMN2	6369h	
27h	COMN3	0000h	

Note 1: Write access from the network to the area from 00h to 0Fh is always disabled. Writes to this area must be performed from places other than the network (e.g. host interface or I<sup>2</sup>C interface).

Note 2: The E<sup>2</sup>PROM data can be rewritten from the Ethernet, the host interface, or the serial interface.

### **8.3 RS232C driver IC (UART connection)**

The Analog Devices ADM3222 is used. It is connected to the S1S60000's UART.

## 9. POWER SUPPLY

A 3.3 V power supply level is generated from the 5 V power supply input to the evaluation board's CN6 connector using a regulator.

## 10. VERIFYING OPERATION

See the S1S60000 Application Notes for the procedure for verifying S1S60000 operation.

Application Note No. 1 Serial to Ethernet Conversion

Application Note No. 2 Ping Response Methods

Application Note No. 3 UDP/IP Communication Endpoint Usage

Application Note No. 4 TCP/IP Communication Endpoint Usage



# APPENDIX 1: CIRCUIT DIAGRAMS

This section presents the circuit diagrams (3 diagrams) for the S1S60000 evaluation board.

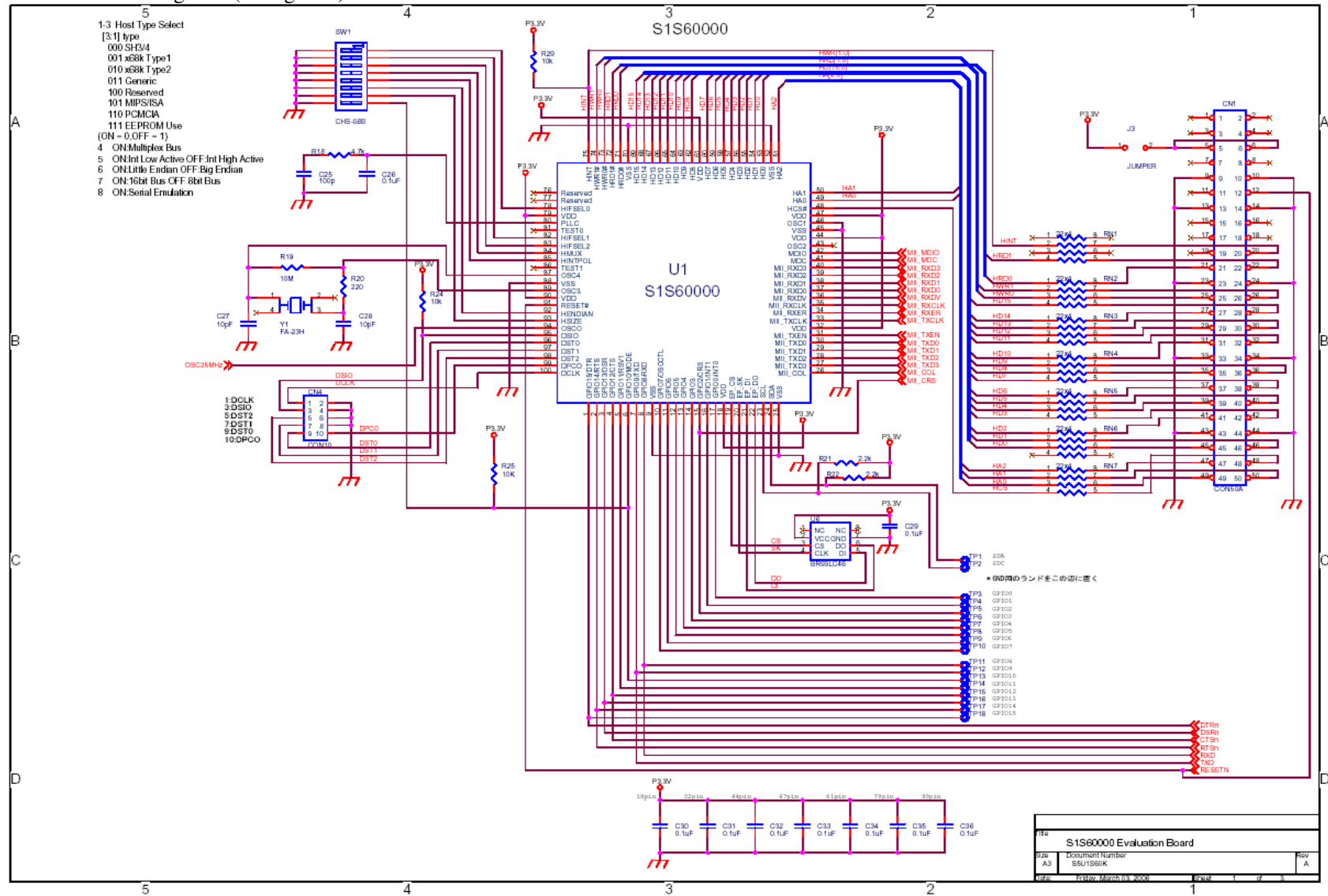



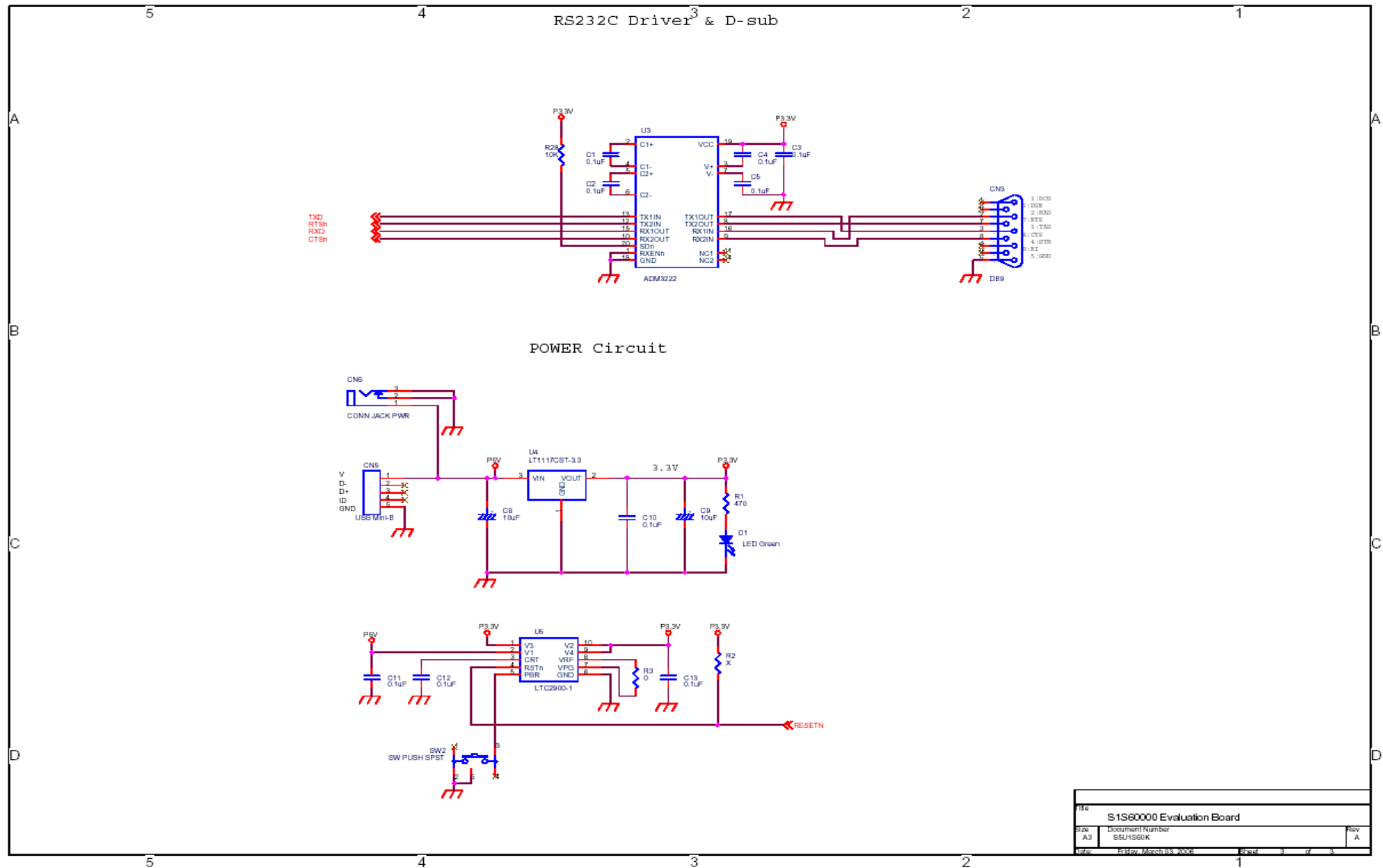

**REVISION HISTORY**

Rev. No.	Date	Page	Category	Contents
Rev 1.1	2007/xx/xx	All		

### AMERICA

#### EPSON ELECTRONICS AMERICA, INC.

##### HEADQUARTERS

2580 Orchard Parkway  
San Jose, CA 95131, USA  
Phone: +1-800-228-3964 FAX: +1-408-922-0238

##### SALES OFFICES

###### Northeast

301 Edgewater Place, Suite 210  
Wakefield, MA 01880, U.S.A.  
Phone: +1-800-922-7667 FAX: +1-781-246-5443

### EUROPE

#### EPSON EUROPE ELECTRONICS GmbH

##### HEADQUARTERS

Riesstrasse 15  
80992 Munich, GERMANY  
Phone: +49-89-14005-0 FAX: +49-89-14005-110

##### DÜSSELDORF BRANCH OFFICE

Altstadtstrasse 176  
51379 Leverkusen, GERMANY  
Phone: +49-2171-5045-0 FAX: +49-2171-5045-10

##### FRENCH BRANCH OFFICE

1 Avenue de l'Atlantique, LP 915 Les Conquerants  
Z.A. de Courtaboeuf 2, F-91976 Les Ulis Cedex, FRANCE  
Phone: +33-1-64862350 FAX: +33-1-64862355

##### UK & IRELAND BRANCH OFFICE

8 The Square, Stockley Park, Uxbridge  
Middx UB11 1FW, UNITED KINGDOM  
Phone: +44-1295-750-216/+44-1342-824451  
FAX: +44-89-14005 446/447

##### Scotland Design Center

Integration House, The Alba Campus  
Livingston West Lothian, EH54 7EG, SCOTLAND  
Phone: +44-1506-605040 FAX: +44-1506-605041

### ASIA

#### EPSON (CHINA) CO., LTD.

23F, Beijing Silver Tower 2# North RD DongSanHuan  
ChaoYang District, Beijing, CHINA  
Phone: +86-10-6410-6655 FAX: +86-10-6410-7320

##### SHANGHAI BRANCH

7F, High-Tech Bldg., 900, Yishan Road,  
Shanghai 200233, CHINA  
Phone: +86-21-5423-5522 FAX: +86-21-5423-5512

#### EPSON HONG KONG LTD.

20/F., Harbour Centre, 25 Harbour Road  
Wanchai, Hong Kong  
Phone: +852-2585-4600 FAX: +852-2827-4346  
Telex: 65542 EPSCO HX

#### EPSON Electronic Technology Development (Shenzhen) LTD.

12/F, Dawning Mansion, Keji South 12th Road,  
Hi-Tech Park, Shenzhen  
Phone: +86-755-2699-3828 FAX: +86-755-2699-3838

#### EPSON TAIWAN TECHNOLOGY & TRADING LTD.

14F, No. 7, Song Ren Road,  
Taipei 110  
Phone: +886-2-8786-6688 FAX: +886-2-8786-6660

#### EPSON SINGAPORE PTE., LTD.

1 HarbourFront Place,  
#03-02 HarbourFront Tower One, Singapore 098633  
Phone: +65-6586-5500 FAX: +65-6271-3182

#### SEIKO EPSON CORPORATION

##### KOREA OFFICE

50F, KLI 63 Bldg., 60 Yoido-dong  
Youngdeungpo-Ku, Seoul, 150-763, KOREA  
Phone: +82-2-784-6027 FAX: +82-2-767-3677

##### GUMI OFFICE

2F, Grand B/D, 457-4 Songjeong-dong,  
Gumi-City, KOREA  
Phone: +82-54-454-6027 FAX: +82-54-454-6093

---

#### SEIKO EPSON CORPORATION SEMICONDUCTOR OPERATIONS DIVISION

##### IC Sales Dept.

##### IC International Sales Group

421-8, Hino, Hino-shi, Tokyo 191-8501, JAPAN  
Phone: +81-42-587-5814 FAX: +81-42-587-5117