



Chipsmall Limited consists of a professional team with an average of over 10 year of expertise in the distribution of electronic components. Based in Hongkong, we have already established firm and mutual-benefit business relationships with customers from,Europe,America and south Asia,supplying obsolete and hard-to-find components to meet their specific needs.

With the principle of “Quality Parts,Customers Priority,Honest Operation,and Considerate Service”,our business mainly focus on the distribution of electronic components. Line cards we deal with include Microchip,ALPS,ROHM,Xilinx,Pulse,ON,Everlight and Freescale. Main products comprise IC,Modules,Potentiometer,IC Socket,Relay,Connector.Our parts cover such applications as commercial,industrial, and automotives areas.

We are looking forward to setting up business relationship with you and hope to provide you with the best service and solution. Let us make a better world for our industry!



Contact us

Tel: +86-755-8981 8866 Fax: +86-755-8427 6832

Email & Skype: info@chipsmall.com Web: www.chipsmall.com

Address: A1208, Overseas Decoration Building, #122 Zhenhua RD., Futian, Shenzhen, China





S6SBP401AJ0SA1001, S6SBP401AM2SA100

Automotive Evaluation Board Operation Guide

Doc. No. 002-08764 Rev. *A

Cypress Semiconductor
198 Champion Court
San Jose, CA 95134-1709
<http://www.cypress.com>

Copyrights

© Cypress Semiconductor Corporation, 2015-2016. The information contained herein is subject to change without notice. Cypress Semiconductor Corporation assumes no responsibility for the use of any circuitry other than circuitry embodied in a Cypress product. Nor does it convey or imply any license under patent or other rights. Cypress products are not warranted nor intended to be used for medical, life support, life saving, critical control or safety applications, unless pursuant to an express written agreement with Cypress. Furthermore, Cypress does not authorize its products for use as critical components in life-support systems where a malfunction or failure may reasonably be expected to result in significant injury to the user. The inclusion of Cypress products in life-support systems application implies that the manufacturer assumes all risk of such use and in doing so indemnifies Cypress against all charges.

Trademarks

All other trademarks or registered trademarks referenced herein are property of the respective corporations.

Source Code

Any Source Code (software and/or firmware) is owned by Cypress Semiconductor Corporation (Cypress) and is protected by and subject to worldwide patent protection (United States and foreign), United States copyright laws and international treaty provisions. Cypress hereby grants to licensee a personal, non-exclusive, non-transferable license to copy, use, modify, create derivative works of, and compile the Cypress Source Code and derivative works for the sole purpose of creating custom software and or firmware in support of licensee product to be used only in conjunction with a Cypress integrated circuit as specified in the applicable agreement. Any reproduction, modification, translation, compilation, or representation of this Source Code except as specified above is prohibited without the express written permission of Cypress.

Disclaimer

CYPRESS MAKES NO WARRANTY OF ANY KIND, EXPRESS OR IMPLIED, WITH REGARD TO THIS MATERIAL, INCLUDING, BUT NOT LIMITED TO, THE IMPLIED WARRANTIES OF MERCHANTABILITY AND FITNESS FOR A PARTICULAR PURPOSE. Cypress reserves the right to make changes without further notice to the materials described herein. Cypress does not assume any liability arising out of the application or use of any product or circuit described herein. Cypress does not authorize its products for use as critical components in life-support systems where a malfunction or failure may reasonably be expected to result in significant injury to the user. The inclusion of Cypress' product in a life-support systems application implies that the manufacturer assumes all risk of such use and in doing so indemnifies Cypress against all charges.

Use may be limited by and subject to the applicable Cypress software license agreement.

Preface



This manual explains how to use the evaluation board. Be sure to read this manual before using the product. For this product, please consult with sales representatives or support representatives.

Handling and Use

Handling and use of this product and notes regarding its safe use are described in the manuals.

Follow the instructions in the manuals to use this product.

Keep this manual at hand so that you can refer to it anytime during use of this product.

Notice on this Document

All information included in this document is current as of the date it is issued. Such information is subject to change without any prior notice.

Please confirm the latest relevant information with the sales representatives

Cautions



Caution of the Products Described in this Document

The following precautions apply to the product described in this manual.

 WARNING	Indicates a potentially hazardous situation which could result in death or serious injury and/or a fault in the user's system if the product is not used correctly.
--	---

Electric Shock, Damage	Before performing any operation described in this manual, turn off all the power supplies to the system. Performing such an operation with the power on may cause an electric shock or device fault.
Electric Shock, Damage	Once the product has been turned on, do not touch any metal part of it. Doing so may cause an electric shock or device fault.

 CAUTION	Indicates the presence of a hazard that may cause a minor or moderate injury, damages to this product or devices connected to it, or may cause to lose software resources and other properties such as data, if the device is not used appropriately.
--	---

Cuts, Damage	Before moving the product, be sure to turn off all the power supplies and unplug the cables. Watch your step when carrying the product. Do not use the product in an unstable location such as a place exposed to strong vibration or a sloping surface. Doing so may cause the product to fall, resulting in an injury or fault.
Cuts	The product contains sharp edges that are left unavoidably exposed, such as jumper plugs. Handle the product with due care not to get injured with such pointed parts.
Damage	Do not place anything on the product or expose the product to physical shocks. Do not carry the product after the power has been turned on. Doing so may cause a malfunction due to overloading or shock.
Damage	Since the product contains many electronic components, keep it away from direct sunlight, high temperature, and high humidity to prevent condensation. Do not use or store the product where it is exposed to much dust or a strong magnetic or electric field for an extended period of time. Inappropriate operating or storage environments may cause a fault.
Damage	Use the product within the ranges given in the specifications. Operation over the specified ranges may cause a fault.
Damage	To prevent electrostatic breakdown, do not let your finger or other object come into contact with the metal parts of any of the connectors. Before handling the product, touch a metal object (such as a door knob) to discharge any static electricity from your body.

Damage	When turning the power on or off, follow the relevant procedure as described in this document. Before turning the power on, in particular, be sure to finish making all the required connections. Furthermore, be sure to configure and use the product by following the instructions given in this document. Using the product incorrectly or inappropriately may cause a fault.
Damage	Always turn the power off before connecting or disconnecting any cables from the product. When unplugging a cable, unplug the cable by holding the connector part without pulling on the cable itself. Pulling the cable itself or bending it may expose or disconnect the cable core, resulting in a fault.
Damage	Because the product has no casing, it is recommended that it be stored in the original packaging. Transporting the product may cause a damage or fault. Therefore, keep the packaging materials and use them when re-shipping the product.

Contents



1. Description	7
2. Evaluation Board Specification	8
3. PIN Descriptions	9
3.1 Input/Output Descriptions	9
3.2 Jumper Descriptions	11
4. Setup	12
4.1 Connecting	12
4.2 Verification	13
5. Layout	14
5.1 Component Layout	14
5.2 Wiring Layout.....	14
6. Circuit Schematic	16
7. Component List	17
8. Ordering Information	19
Revision History	20
Document Revision History	20

1. Description



S6SBP401AJ0SA1001 and S6SBP401AM2SA1001 are the evaluation kit for power block of automotive ADAS platform.

These boards implement S6BP401A of power management IC.

It is necessary to prepare DC power supply.

Figure 1-1. Board Outline

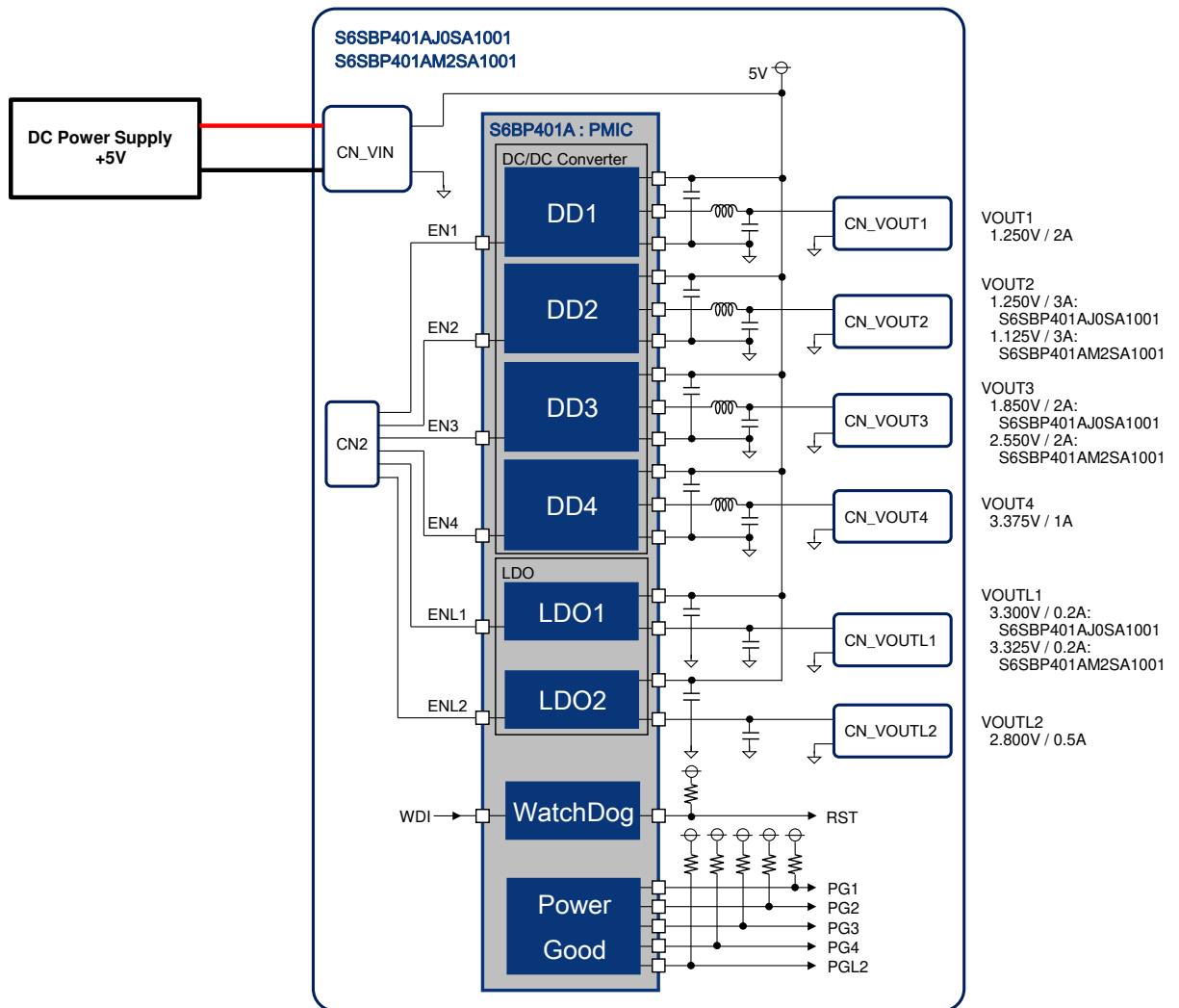

2. Evaluation Board Specification



Table 2-1. Evaluation Board Specification

Item		Symbol	Min.	Typ.	Max.	Unit
Input Voltage		VIN	4.5	5.0	5.5	V
Output Voltage	S6SBP401AJ0SA1001	VOUT1	-	1.250	-	V
		VOUT2	-	1.250	-	V
		VOUT3	-	1.850	-	V
		VOUT4	-	3.375	-	V
		VOU TL1	-	3.300	-	V
		VOU TL2	-	2.800	-	V
	S6SBP401AM2SA1001	VOUT1	-	1.250	-	V
		VOUT2	-	1.125	-	V
		VOUT3	-	2.550	-	V
		VOUT4	-	3.375	-	V
		VOU TL1	-	3.325	-	V
		VOU TL2	-	2.800	-	V
Output Current	S6SBP401AJ0SA1001 S6SBP401AM2SA1001	IOUT1	-	-	2.0	A
		IOUT2	-	-	3.0	A
		IOUT3	-	-	2.0	A
		IOUT4	-	-	1.0	A
		IOUT L1	-	-	0.2	A
		IOUT L2	-	-	0.5	A

3. PIN Descriptions



3.1 Input/Output Descriptions

Table 3-1. Input/Output Descriptions

Connector Symbol		I/O	Function Description
CN_VIN	VIN	I	+5Vdc power supply terminal
	GND	-	Ground terminal
CN_VOUT1	VOUT1	O	CH1 DC/DC convertor output terminal
	GND	-	Ground terminal
CN_VOUT2	VOUT2	O	CH2DC/DC convertor output terminal
	GND	-	Ground terminal
CN_VOUT3	VOUT3	O	CH3DC/DC convertor output terminal
	GND	-	Ground terminal
CN_VOUT4	VOUT4	O	CH4DC/DC convertor output terminal
	GND	-	Ground terminal
CN_VOCTL1	VOCTL1	O	CH1 LDO output terminal
	GND	-	Ground terminal
CN_VOCTL2	VOCTL2	O	CH2 LDO output terminal
	GND	-	Ground terminal
CN1	SYNC	I	External clock input terminal. Please use by referring to the data sheet of S6BP401A.
	WDI	I	Trigger input terminal of watchdog timer. Please use by referring to the data sheet of S6BP401A.
	RST	O	Reset output terminal of watchdog timer. Please use by referring to the data sheet of S6BP401A.
	NC	-	-
CN2	EN1, EN2, EN3, EN4	I	CH1 -CH4 DC/DC convertor enable terminal
	ENL1, ENL2	I	CH1,CH2 LDO enable terminal
CN3	PG1, PG2, PG3, PG4	O	CH1 -CH4 DC/DC convertor power good terminal
	PGL2	O	CH1,CH2 LDO power good terminal
	VCCPullUP	I	Voltage supply terminal for the pull up resistors of the power good

Figure 3-1. Pin Layout

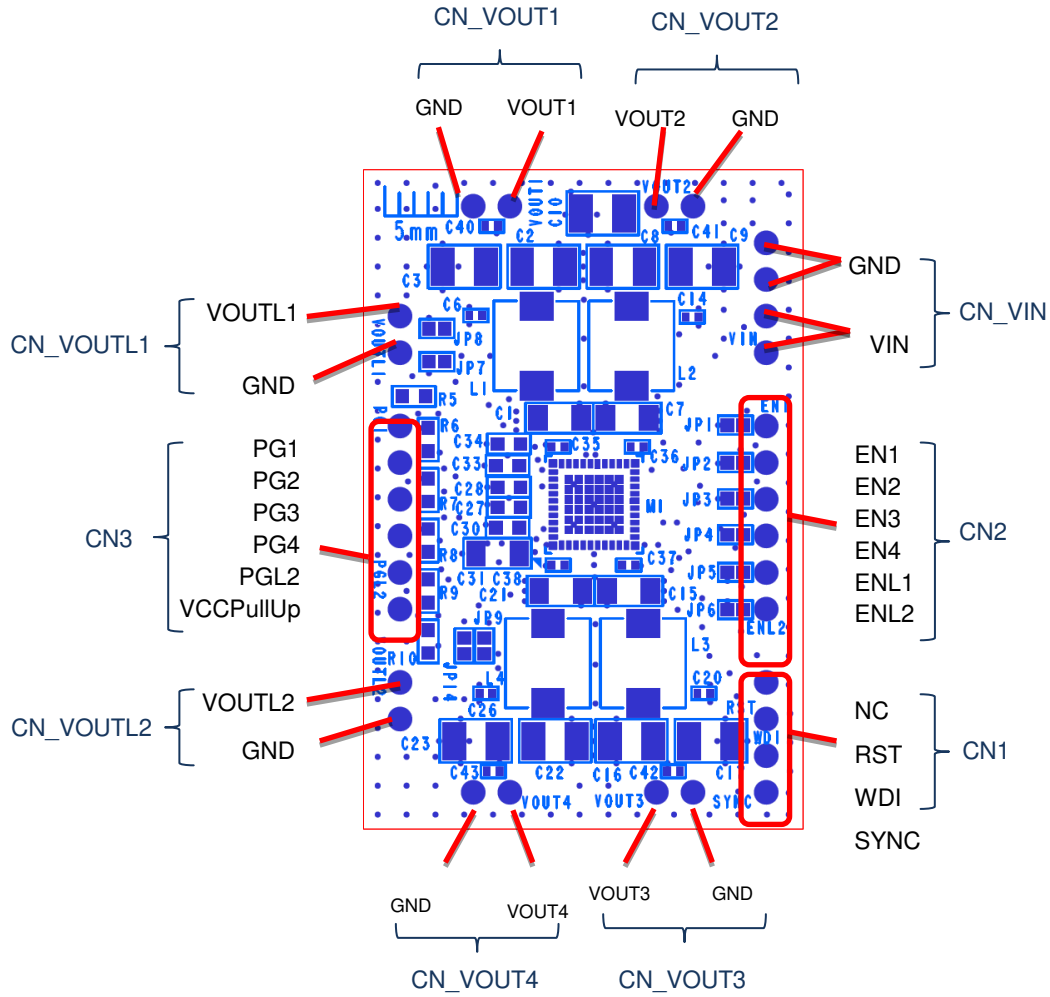

3.2 Jumper Descriptions

Table 3-2. Jumper Descriptions

Jumper	Description	Initial Setting
JP1	Shorted between VIN and EN1 JP1 Short: EN1 pin is set to the H level. JP1 Open: EN1 pin is set to the L level. Input external signal to EN1 pin. Don't input external signal to EN1 pin with shorted JP1.	Open
JP2	Shorted between VIN and EN2 JP2 Short: EN2 pin is set to the H level. JP2 Open: EN2 pin is set to the L level. Input external signal to EN2 pin. Don't input external signal to EN2 pin with shorted JP2.	Open
JP3	Shorted between VIN and EN3 JP3 Short: EN3 pin is set to the H level. JP3 Open: EN3 pin is set to the L level. Input external signal to EN3 pin. Don't input external signal to EN3 pin with shorted JP3.	Open
JP4	Shorted between VIN and EN4 JP4 Short: EN4 pin is set to the H level. JP4 Open: EN4 pin is set to the L level. Input external signal to EN4 pin. Don't input external signal to EN4 pin with shorted JP4.	Open
JP5	Shorted between VIN and ENL1 JP5 Short: ENL1 pin is set to the H level. JP5 Open: ENL1 pin is set to the L level. Input external signal to ENL1 pin. Don't input external signal to ENL1 pin with shorted JP5.	Open
JP6	Shorted between VIN and ENL2 JP6 Short: ENL2 pin is set to the H level. JP6 Open: ENL2 pin is set to the L level. Input external signal to ENL2 pin. Don't input external signal to ENL2 pin with shorted JP6.	Open
JP7	Shorted VIN or VOUTL1 to power good pin through resistor. JP7 Short: Shorted between VOUTL1 and power good pin through resistor.	Open
JP8	JP8 Short: Shorted between VIN and power good pin through resistor. JP7 and JP8 must not be shorted simultaneously.	Short
JP9	Shorted VIN or VOUT4 to PVCCL2 of IC 37 pin. JP9 Short: Shorted between VIN and PVCCL2.	Short
JP14	JP14 Short: Shorted between VOUT4 and PVCCL2. JP9 and JP14 must not be shorted simultaneously.	Open

4. Setup



4.1 Connecting

1. Connect the board to the power supply, load equipment and voltage meter as below.

Figure 4-1. Connecting the Board and Some Equipment

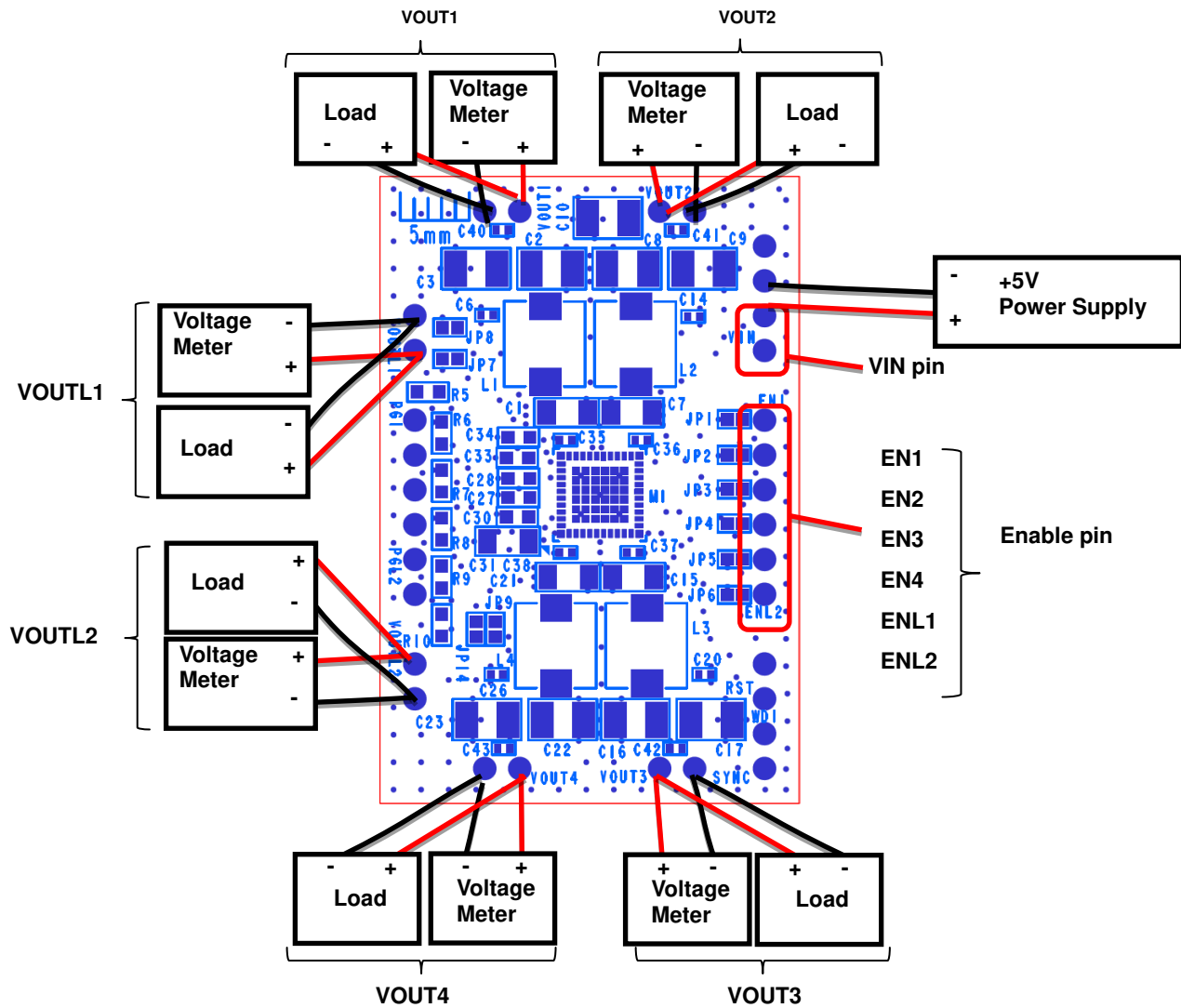

4.2 Verification

1. Turn on +5V power supply.
2. Connect some enable pin to VIN, then, each DC/DC (or LDO) channel will start output.
3. Check that each output voltage is the same as the 'Output Voltage' of Figure 2-1 Evaluation Board Specification.

5. Layout



5.1 Component Layout

Figure 5-1. Evaluation Board Component Layout

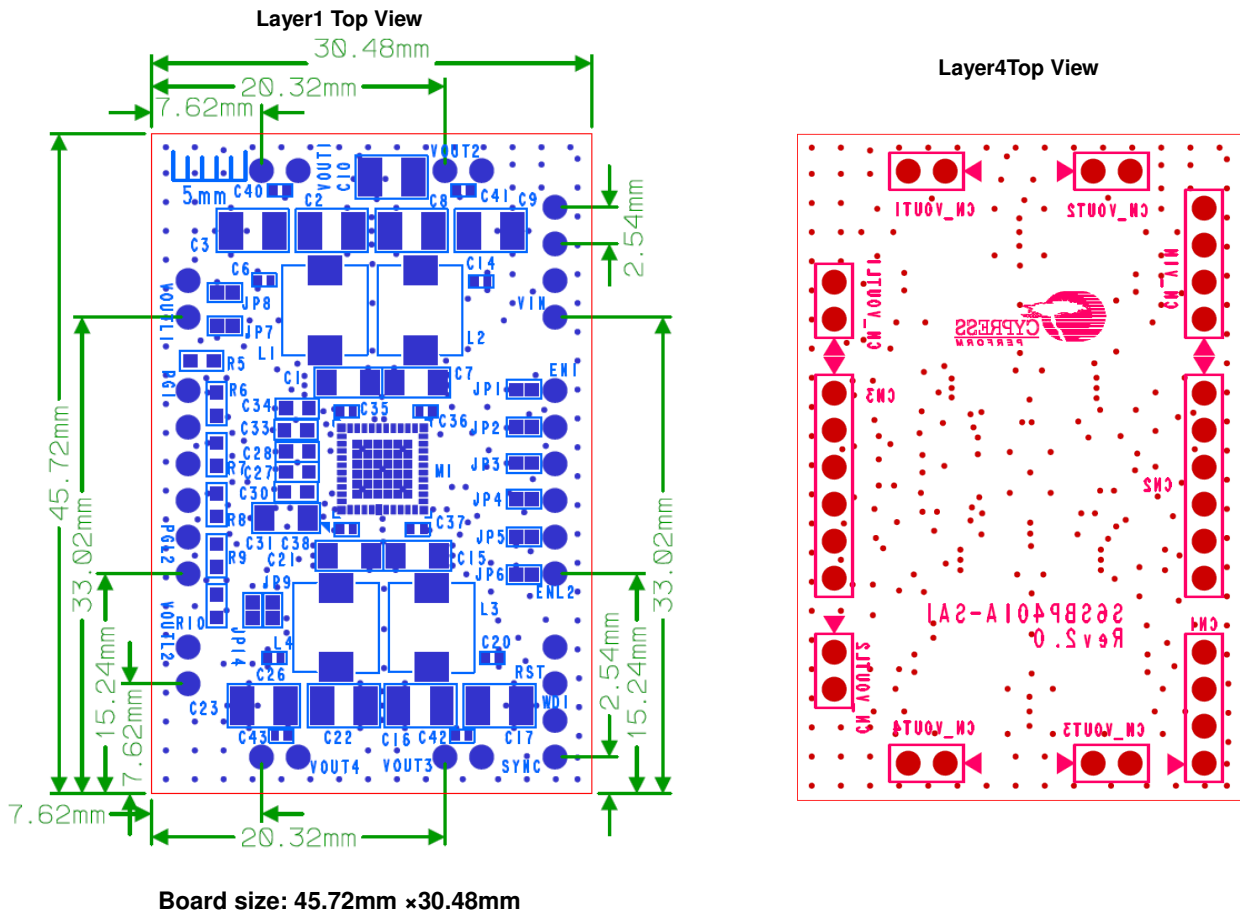

5.2 Wiring Layout

Figure 5-2. Evaluation Board Wiring Layout

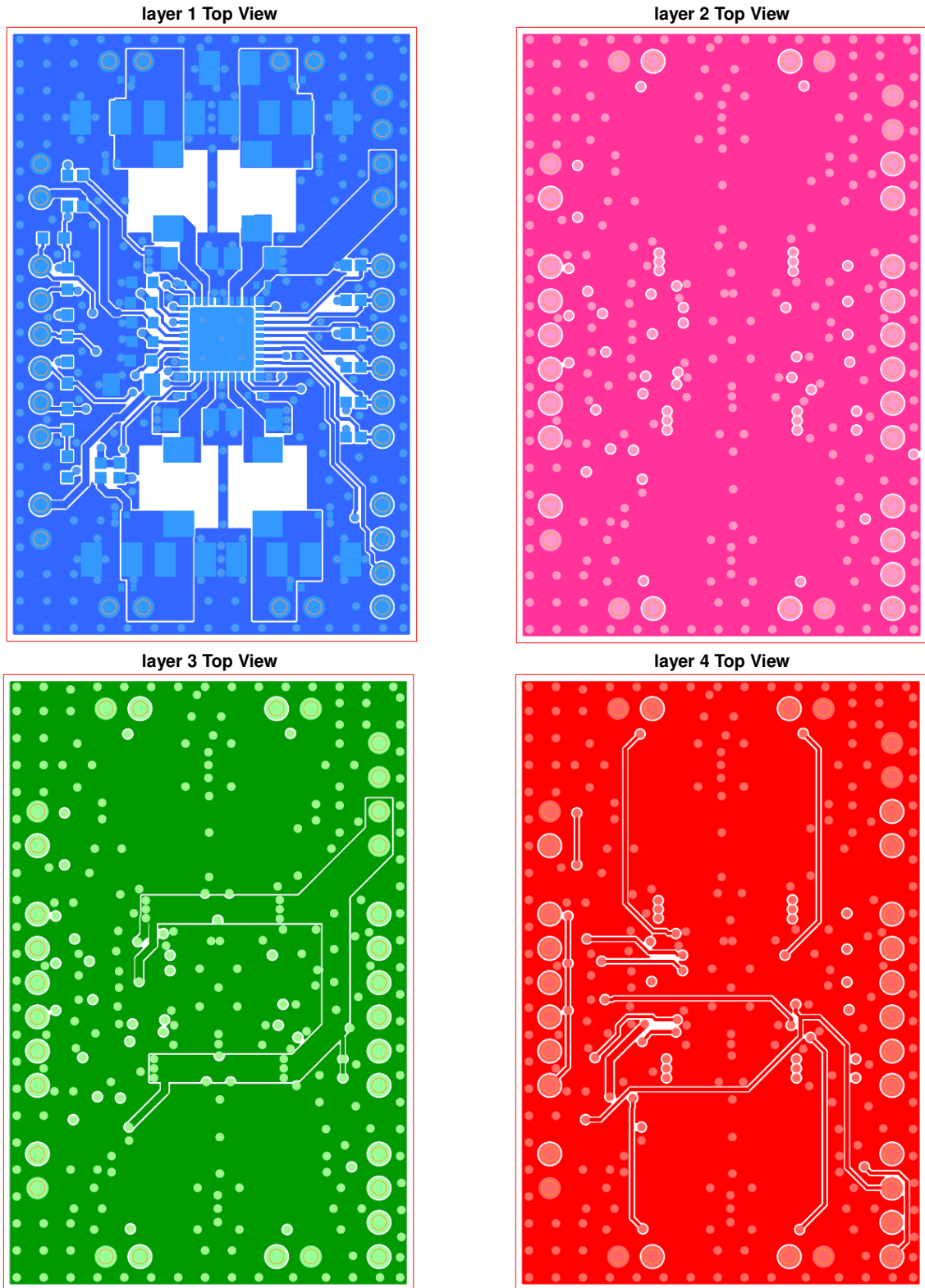

6. Circuit Schematic



Figure 6-1. Evaluation Board Circuit Schematic

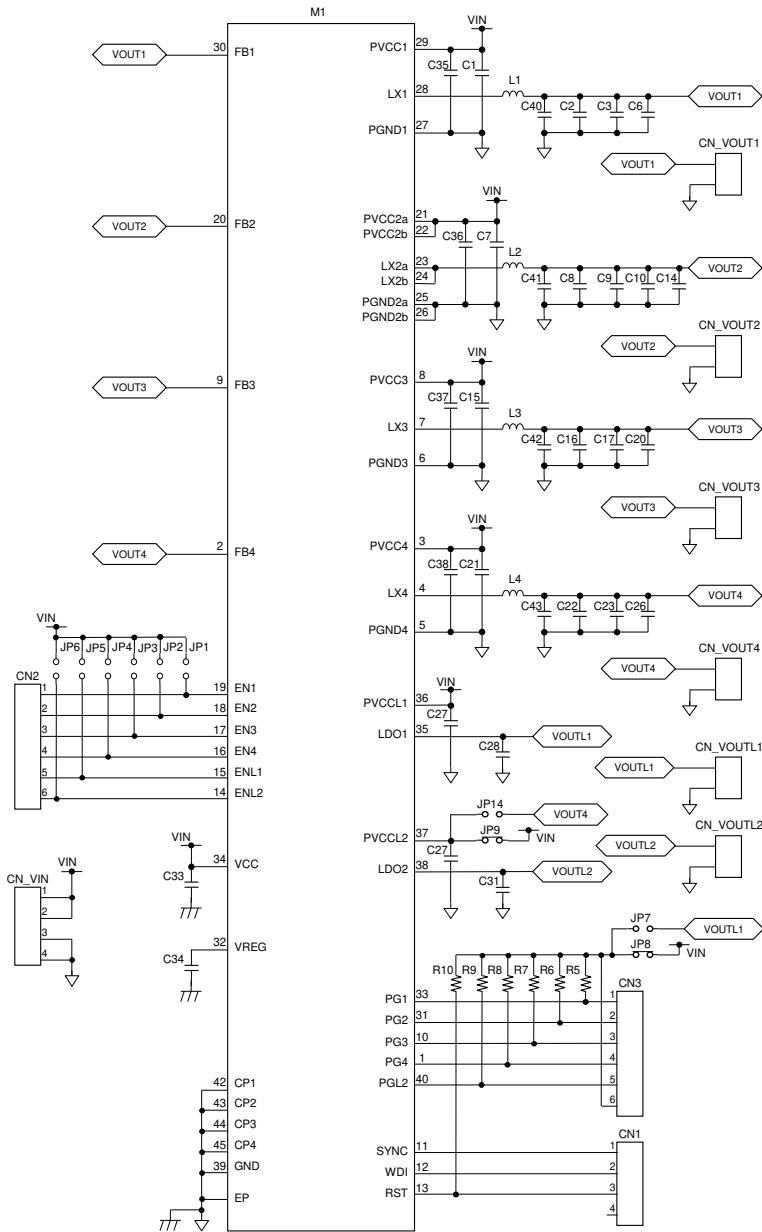

7. Component List



Table 7-1. Evaluation Board Component List

No.	Component	Parts Number	Vendor	Value	Rated Voltage(V)	Rated Current(A)	Remarks
1	C1	CGA5L1X7R1C106K160AC	TDK	10 μ F	16	-	-
2	C2	CGA6P1X7R1C226M250AC	TDK	22 μ F	16	-	-
3	C3	CGA6P1X7R1C226M250AC	TDK	22 μ F	16	-	-
4	C6	CGA2B3X7R1H104K050BB	TDK	0.1 μ F	50	-	-
5	C7	CGA5L1X7R1C106K160AC	TDK	10 μ F	16	-	-
6	C8	CGA6P1X7R1C226M250AC	TDK	22 μ F	16	-	-
7	C9	CGA6P1X7R1C226M250AC	TDK	22 μ F	16	-	-
8	C10	CGA6P1X7R1C226M250AC	TDK	22 μ F	16	-	-
9	C14	CGA2B3X7R1H104K050BB	TDK	0.1 μ F	50	-	-
10	C15	CGA5L1X7R1C106K160AC	TDK	10 μ F	16	-	-
11	C16	CGA6P1X7R1C226M250AC	TDK	22 μ F	16	-	-
12	C17	CGA6P1X7R1C226M250AC	TDK	22 μ F	16	-	-
13	C20	CGA2B3X7R1H104K050BB	TDK	0.1 μ F	50	-	-
14	C21	CGA5L1X7R1C106K160AC	TDK	10 μ F	16	-	-
15	C22	CGA6P1X7R1C226M250AC	TDK	22 μ F	16	-	-
16	C23	CGA6P1X7R1C226M250AC	TDK	22 μ F	16	-	-
17	C26	CGA2B3X7R1H104K050BB	TDK	0.1 μ F	50	-	-
18	C27	CGA3E1X7R1C105M080AC	TDK	1 μ F	16	-	-
19	C28	CGA3E1X7R1C105M080AC	TDK	1 μ F	16	-	-
20	C30	CGA3E1X7R1C105M080AC	TDK	1 μ F	16	-	-
21	C31	CGA5L1X7R1C106K160AC	TDK	10 μ F	16	-	-
22	C33	CGA3E1X7R1C105M080AC	TDK	1 μ F	16	-	-
23	C34	CGA3E1X7R1C105M080AC	TDK	1 μ F	16	-	-
24	C35	CGA2B3X7R1H104K050BB	TDK	0.1 μ F	50	-	-
25	C36	CGA2B3X7R1H104K050BB	TDK	0.1 μ F	50	-	-
26	C37	CGA2B3X7R1H104K050BB	TDK	0.1 μ F	50	-	-
27	C38	CGA2B3X7R1H104K050BB	TDK	0.1 μ F	50	-	-
28	C40	CGA2B3X7R1H104K050BB	TDK	0.1 μ F	50	-	-

No.	Component	Parts Number	Vendor	Value	Rated Voltage(V)	Rated Current(A)	Remarks
29	C41	CGA2B3X7R1H104K050BB	TDK	0.1μF	50	-	-
30	C42	CGA2B3X7R1H104K050BB	TDK	0.1μF	50	-	-
31	C43	CGA2B3X7R1H104K050BB	TDK	0.1μF	50	-	-
32	L1	CLF6045T-1R5N-D	TDK	1.5μH	-	4.2	-
33	L2	CLF6045T-1R5N-D	TDK	1.5μH	-	4.2	-
34	L3	CLF6045T-1R5N-D	TDK	1.5μH	-	4.2	-
35	L4	CLF6045T-1R5N-D	TDK	1.5μH	-	4.2	-
36	M1	S6BP401AJ0SN1B000	Cypress	-	-	-	S6SBP40 1AJ0SA10 01
		S6BP401AM2SN1B000					S6SBP40 1AM2SA1 001
37	R5	RG1608P-473-B	SSM	47kΩ	-	-	-
38	R6	RG1608P-473-B	SSM	47 kΩ	-	-	-
39	R7	RG1608P-473-B	SSM	47 kΩ	-	-	-
40	R8	RG1608P-473-B	SSM	47 kΩ	-	-	-
41	R9	RG1608P-473-B	SSM	47 kΩ	-	-	-
42	R10	RG1608P-473-B	SSM	47 kΩ	-	-	-

TDK : TDK Corporation
 Cypress : Cypress Semiconductor Corp
 SSM : SUSUMU CO., LTD.
 NMT : No mount.

These components are compliant with RoHS, and please ask each vendor for details if necessary.

8. Ordering Information



Table 8-1. Ordering Information

Part Number	EV B Revision	Note
S6SBP401AJ0SA1001	S6SBP401A-SA1	Mounted IC: S6BP401AJ0SN1B000
S6SBP401AM2SA1001	Rev 2.0	Mounted IC: S6BP401AM2SN1B000

Revision History



Document Revision History

Document Title: S6SBP401AJ0SA1001, S6SBP401AM2SA100 Automotive Evaluation Board Operation Guide

Document Number: 002-08764

Revision	Issue Date	Origin of Change	Description of Change
**	09/11/2015	TAOA	Initial release
*A	02/05/2016	TAOA	Migrated Spansion Guide from S6SBP401AJ0SA1001_SS901-00045-1v0-E to Cypress format