



Chipsmall Limited consists of a professional team with an average of over 10 year of expertise in the distribution of electronic components. Based in Hongkong, we have already established firm and mutual-benefit business relationships with customers from,Europe,America and south Asia,supplying obsolete and hard-to-find components to meet their specific needs.

With the principle of “Quality Parts,Customers Priority,Honest Operation,and Considerate Service”,our business mainly focus on the distribution of electronic components. Line cards we deal with include Microchip,ALPS,ROHM,Xilinx,Pulse,ON,Everlight and Freescale. Main products comprise IC,Modules,Potentiometer,IC Socket,Relay,Connector.Our parts cover such applications as commercial,industrial, and automotives areas.

We are looking forward to setting up business relationship with you and hope to provide you with the best service and solution. Let us make a better world for our industry!



Contact us

Tel: +86-755-8981 8866 Fax: +86-755-8427 6832

Email & Skype: info@chipsmall.com Web: www.chipsmall.com

Address: A1208, Overseas Decoration Building, #122 Zhenhua RD., Futian, Shenzhen, China



Customer Information Sheet

DRAWING No.: S8071-46R

SHEET 2 OF 2

IF IN DOUBT - ASK

©

NOT TO SCALE

THIRD ANGLE PROJECTION

ALL DIMENSIONS IN mm

- NOTES:
1. THIS PRODUCT IS RECOMMENDED FOR USE WITH S07-46 AND S08-46 LED BRIDGE PINS.
 2. ALL PRODUCT IS RoHS AND REACH COMPLIANT.
 3. PRODUCT IS TAPE AND REELED IN GENERAL ACCORDANCE WITH EIA-481-2 (ELECTRONICS INDUSTRIES ASSOCIATION).
 4. PACKAGING = 10,000 COMPONENTS PER REEL.
 5. CURRENT RATING IS DEPENDANT ON USAGE. SEE TEST REPORT HT055XX (LATEST ISSUE) FOR MORE INFORMATION ON CURRENT RATING.

SPECIFICATION:

MATERIAL:
CONTACT = STAINLESS STEEL, 0.15mm THICK
FINISH:
1.0µ - 3.0µ TIN OVER 0.4µ - 1.5µ NICKEL

ELECTRICAL:
CURRENT RATING = 3A - 13A
(SEE NOTE 5)
VOLTAGE RATING = 250V AC/DC

MECHANICAL:
INSERTION FORCE = 25N MAX (INITIAL)
WITHDRAWAL FORCE = 8N MIN (INITIAL)
DURABILITY = 10 CYCLES MAX

ENVIRONMENTAL:
OPERATING TEMPERATURE = -40°C TO +85°C

SOLDERING DATA:
SOLDERING HEAT RESISTANCE = 250°C FOR 10 SECONDS MAX

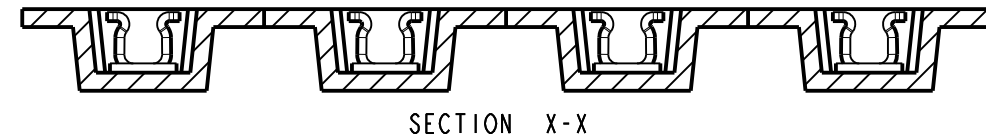
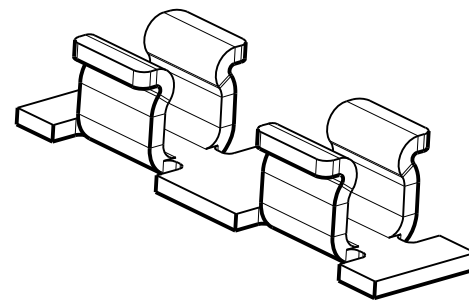
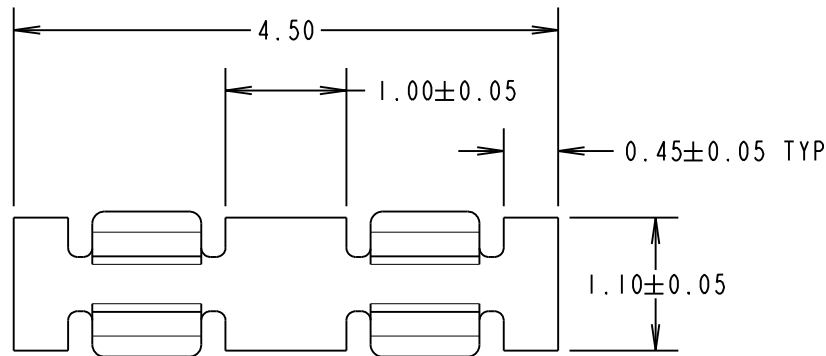
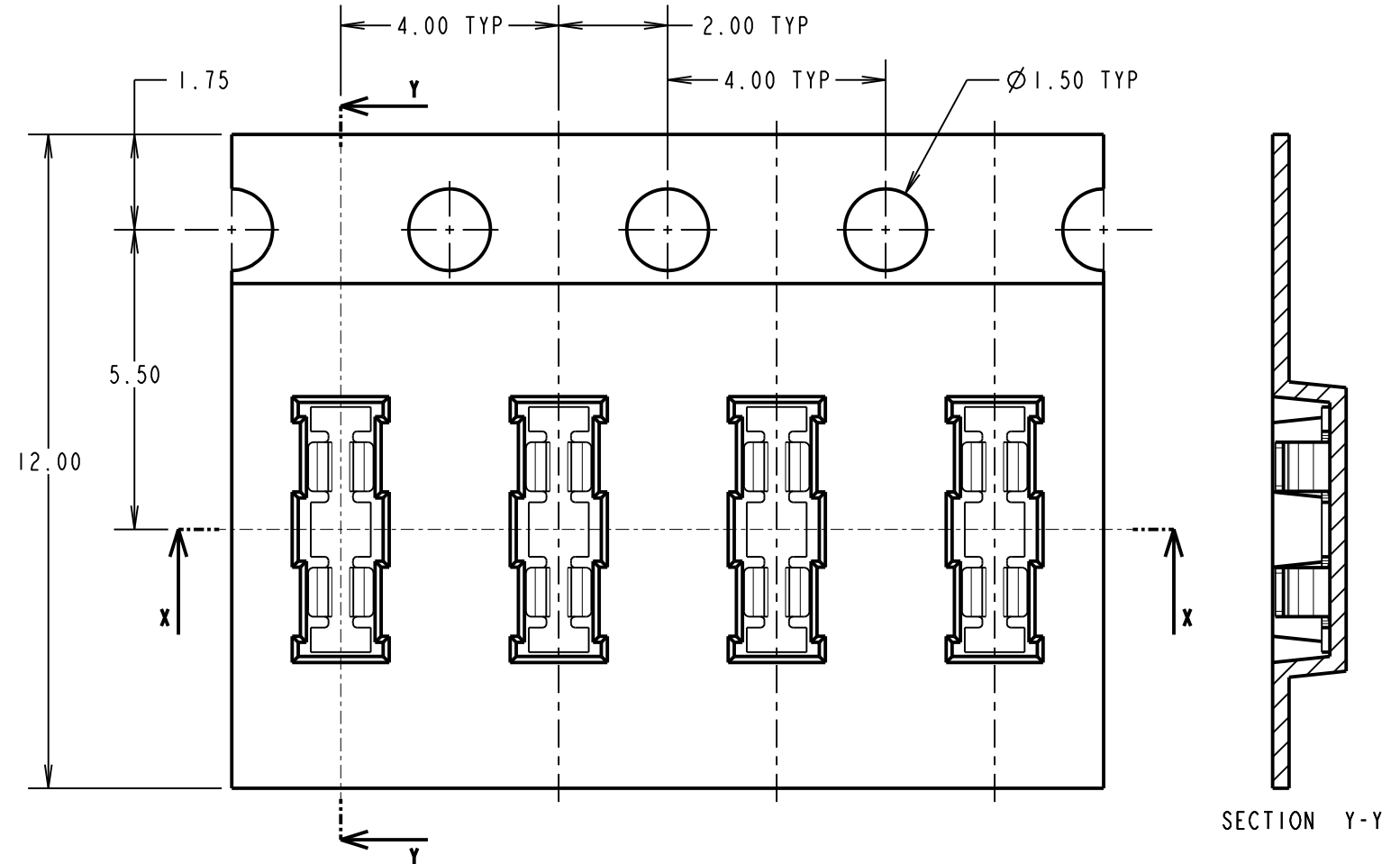
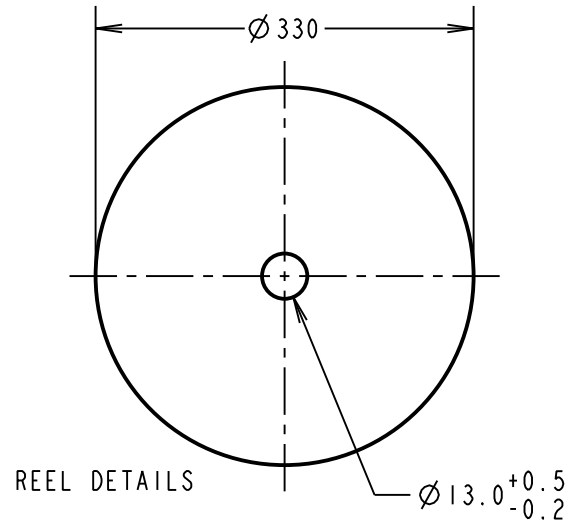

COMPONENT DETAILS

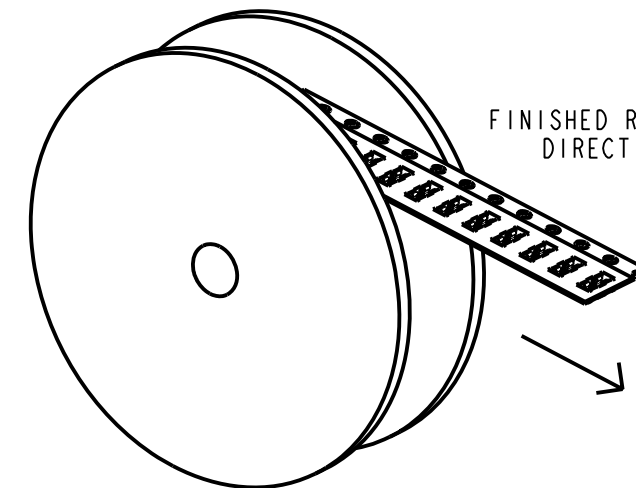
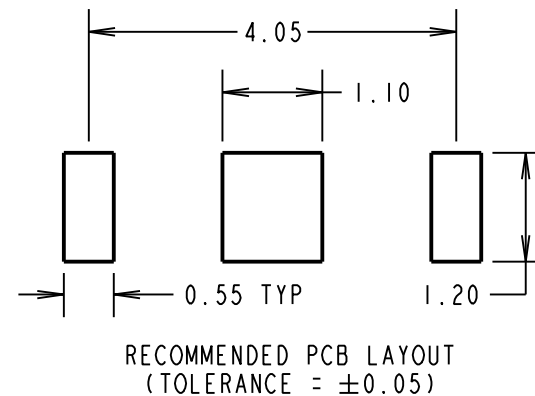
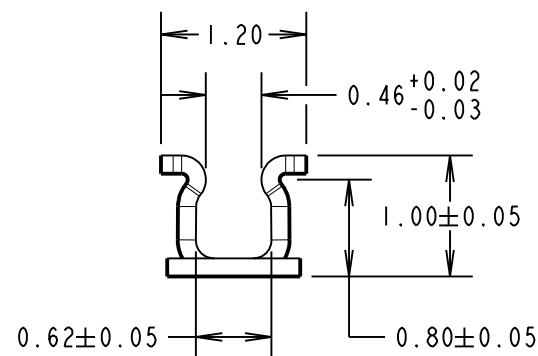
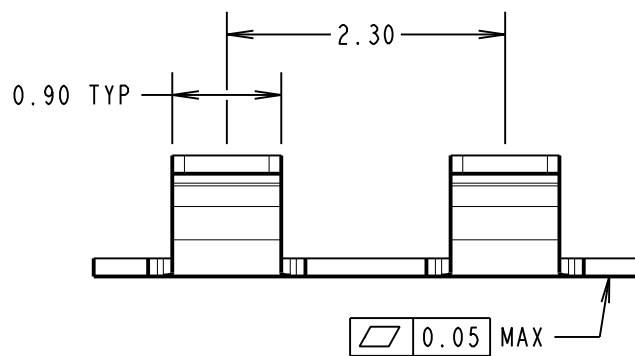

MSP	3	19.04.17	20428
NAME	ISS.	DATE	C/NOTE
APPROVED:		M. PERREN	
CHECKED:		S. BENNETT	
DRAWN:		S. BENNETT	
CUSTOMER REF.:			
ASSEMBLY DRG:			

HARWIN

www.harwin.com
technical@harwin.com

THIS DRAWING AND ANY INFORMATION OR DESCRIPTIVE MATTER SET OUT HEREON ARE CONFIDENTIAL AND COPYRIGHT PROPERTY OF THE HARWIN GROUP AND MUST NOT BE DISCLOSED, LOANED, COPIED OR USED FOR MANUFACTURING, TENDERING OR FOR ANY OTHER PURPOSE WITHOUT THEIR WRITTEN PERMISSION.

TOLERANCES
X. = ±1mm
X.X = ±0.25mm
X.XX = ±0.10mm
X.XXX = ±0.01mm
ANGLES = ±5°
UNLESS STATED

MATERIAL:
SEE ABOVE
FINISH: SEE ABOVE
S/AREA: mm²

TITLE: VERTICAL SMT CABLE AND PIN CLIP

DRAWING NUMBER: S8071-46R

SHT 2 OF 2