



Chipsmall Limited consists of a professional team with an average of over 10 year of expertise in the distribution of electronic components. Based in Hongkong, we have already established firm and mutual-benefit business relationships with customers from,Europe,America and south Asia,supplying obsolete and hard-to-find components to meet their specific needs.

With the principle of “Quality Parts,Customers Priority,Honest Operation,and Considerate Service”,our business mainly focus on the distribution of electronic components. Line cards we deal with include Microchip,ALPS,ROHM,Xilinx,Pulse,ON,Everlight and Freescale. Main products comprise IC,Modules,Potentiometer,IC Socket,Relay,Connector.Our parts cover such applications as commercial,industrial, and automotives areas.

We are looking forward to setting up business relationship with you and hope to provide you with the best service and solution. Let us make a better world for our industry!



Contact us

Tel: +86-755-8981 8866 Fax: +86-755-8427 6832

Email & Skype: info@chipsmall.com Web: www.chipsmall.com

Address: A1208, Overseas Decoration Building, #122 Zhenhua RD., Futian, Shenzhen, China



Highly Reliable and Full-functioned 15-year Life Expectancy

- 5, 12, 15, or 24 V output voltages, and 30, 60, 100, or 150 W power ratings.
- 85 to 132 VAC or 170 to 264 VAC switchable input voltage for international use.
- Equipped with overvoltage and overload protection and remote sensing and control functions.
- Parallel connection of two 150 W Power Supplies possible for loads drawing high current.
- Improved durability.

RCY

Ordering Information

Rated input voltage	Power ratings	Output		Model
		Voltage	Current	
100/200VAC	30 W	5 VDC	6 A	S82L-0305
		12 VDC	2.5 A	S82L-0312
		15 VDC	2 A	S82L-0315
		24 VDC	1.3 A	S82L-0324
	60 W	5 VDC	12 A	S82L-0605
		12 VDC	5 A	S82L-0612
		15 VDC	4 A	S82L-0615
		24 VDC	2.5 A	S82L-0624
	100 W	5 VDC	20 A	S82L-1005
		12 VDC	9 A	S82L-1012
		15 VDC	7.2 A	S82L-1015
		24 VDC	4.6 A	S82L-1024
	150 W	5 VDC	30 A	S82L-1505
		12 VDC	13.5 A	S82L-1512
		15 VDC	10.8 A	S82L-1515
		24 VDC	7 A	S82L-1524

Model Number Legend:

S82L - -

1 2

1. Power Ratings

03: 30 W
06: 60 W
10: 100 W
15: 150 W

2. Output Voltage

05: 5 V
12: 12 V
15: 15 V
24: 24 V

■ Accessory (Order Separately) Connection Kit

Model	S82Y-L15A
-------	-----------

■ Conditions of Guarantee

The guarantee on these products is valid for 7 years from the date of shipment from the factory.

The following conditions apply to the guarantee:

1. The average ambient temperature must be 40°C max.
2. The average load must be 80% max.
3. Standard installation (bottom mounting).

Note: The maximum values must remain within the limits of the derating curve.

If product failure is caused by OMRON within the term of guarantee, OMRON shall be responsible for replacement or repairs.

Failure under any of the following circumstances is excluded from the guarantee.

1. Inappropriate handling or usage.
2. Failure resulted from other causes than those from this product.
3. Modification or repair applied to the product by other than OMRON-certified servicemen.
4. Failure caused by natural disaster, war, riot, etc.

Specifications

■ Ratings/Characteristics

Item		30 W	60 W	100 W	150 W	
Efficiency (typical)		74% to 84% (depending on types)				
Life expectancy		15 yrs. min. (Used at 40°C at the rated input with a 50% load.)				
Input	Voltage (AC only)	Switchable between 100 V (85 to 132 V) and 200 V (170 to 264 V)				
	Frequency	47 to 450 Hz				
	Current (with rated I/O)	100 V input	0.95 A max.	1.5 A max.	2.5 A max.	3.5 A max.
		200 V input	0.6 A max.	0.8 A max.	1.4 A max.	2.1 A max.
	Leakage current (with rated I/O)	100 V input	0.5 mA max.			
		200 V input	1 mA max.			
	Inrush current (with rated I/O)	100 V input	15 A max.			
200 V input		30 A max.				
Noise filter		Yes				
Output	Voltage fluctuation	2% max. (combined input, load, and temperature variations)				
	Voltage adjustment range	±10% (adjustable with variable resistor (V.ADJ))				
	Ripple	1% (p-p) max.				
	Input variation influence	0.3% max. (85 to 132 VAC/170 to 264 VAC input, 100% load)				
	Load variation influence	0.4% max. (with rated input, 0% to 100% load)				
	Temperature variation influence	0.02%/°C max. (0°C to 55°C, with rated input and output)				
	Rise time	300 ms max. (output voltage rise to 90%, with rated input and output)				
	Hold time	20 ms min.				
Additional functions	Overload protection	105% min. of rated load current (typical), inverted L drop, automatic reset (output shut off after 5 s, reset by input reset)				
	Overvoltage protection	120% of rated output voltage (typical), shut-off type, reset by input reset				
	Remote sensing	Yes				
	Remote control	Yes				
	Parallel connection	No			Yes	
Other	Ambient temperature	Operating: See the derating curve in the "Engineering Data" section Storage: -25°C to 85°C				
	Ambient humidity	Operating: 25% to 85% Storage: 20% to 95%				
	Dielectric strength	3.75 VAC, 50/60 Hz for 1 min (between all inputs and outputs) 2.5 VAC, 50/60 Hz for 1 min (between all inputs and the housing) 500 VDC for 1 min (between all outputs and the housing)				
	Insulation resistance	100 MΩ min. at 500 VDC (between all inputs and outputs/housing)				
	Vibration resistance	Malfunction: 10 to 55 Hz, 0.825 mm amplitude (approx. 5G) each in X, Y, and Z directions for 2 hrs.				
	Shock resistance	Malfunction: 294 m/s ² (30G), 3 times each in ±X, ±Y, and ±Z directions				
	Input indicator	Yes (orange)				
	Output indicator	Yes (green)				
	Electromagnetic interference	Meets FCC class B standards				
	Approved standards	UL 1012, CSA E.B.1402C, VDE0160, VDE0805, and EN60950 (IEC 950)				
	Weight	910 g max.	990 g max.	1.1 kg max.	2.2 kg max.	

Engineering Data

Derating Curve

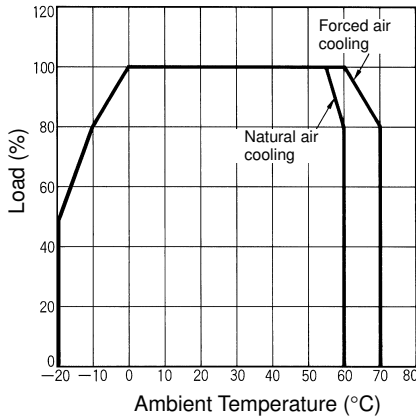

Note: The derating curve differs depending on the mounting direction of the Power Supply. The curve above was obtained with the Power Supply mounted in the standard position.

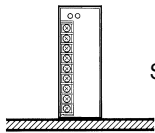

Standard installation

Overload Protection

The protective function prevents damage to the load as well as the Power Supply itself due to overload. If the load current rises above the overload set value (105% of the rated load current), the protective function will engage and the voltage will be reduced. Reset is automatic, so the Power Supply will return to normal operation when the overload condition is corrected.

If an overload condition continues for more than 5 s, the output will be shut off. In this situation, reset is not automatic. The input power must be turned off for at least 30 s, and then turned on again to reset the Power Supply.

Inrush Current, Rise Time, Hold Time

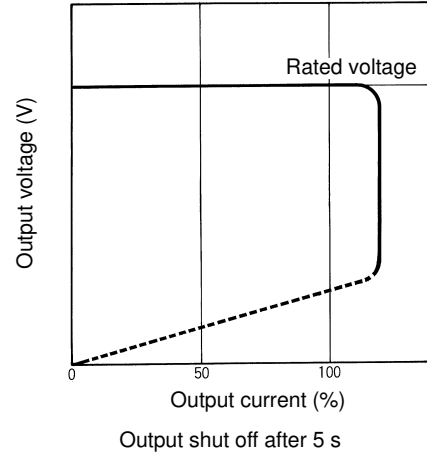
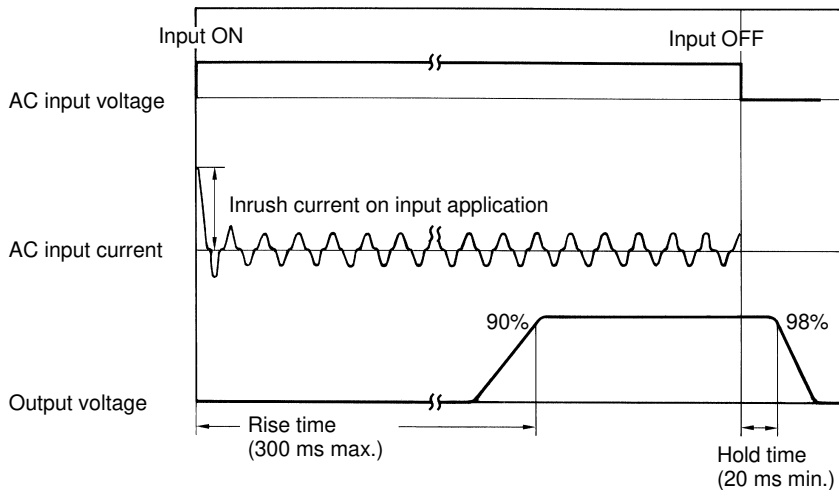

Overvoltage Protection

The protective function prevents damage to the load as well as the Power Supply itself due to overvoltage. The output is shut off if the output voltage rises above about 120% of the rated voltage. The input power must be turned off for at least 30 s, and then turned on again to reset the Power Supply.

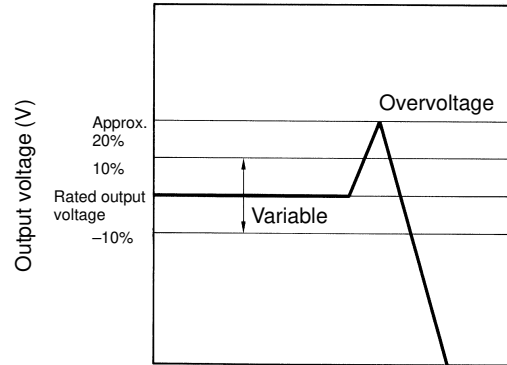

Operation

Remote Sensing Function

This function corrects a voltage drop in the load wiring. When using the remote sensing function, remove the short bars from the remote sensing terminals as shown in the following diagram.

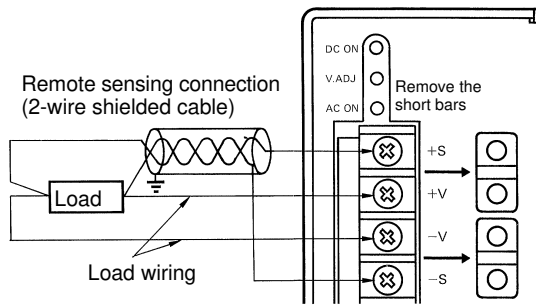

Remote Control Function

This function allows the output voltage to be turned on and off with an external signal (as long as the input voltage is being applied). When using the remote control function, remove the short bar (attached at ex-factory condition) from the remote control terminals and connect a switch or transistor as shown in the diagram below.

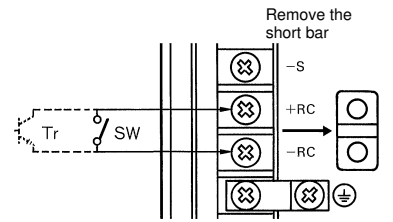

Use a transistor with $V_{CE} > 20\text{ V}$ and $I_C > 5\text{ mA}$.

- Note:**
1. When the voltage drop in the load wiring is large, the overvoltage protection function might engage due to the increase in voltage to correct the voltage drop, so be sure to use high capacity wiring.
 2. If the +S and +V terminals are left unconnected, the overvoltage protection function will engage and the output voltage will be cut off. If the -S and -V terminals are left unconnected, the output voltage will increase about 5%.

Level	Output voltage
L (0.8 V max.)	ON
H (2 V min.)	OFF

Note: The remote control circuit is insulated from input, output, and GR.

Block Diagram

- S82L-03□□ (30 W)
- S82L-06□□ (60 W)
- S82L-10□□ (100 W)

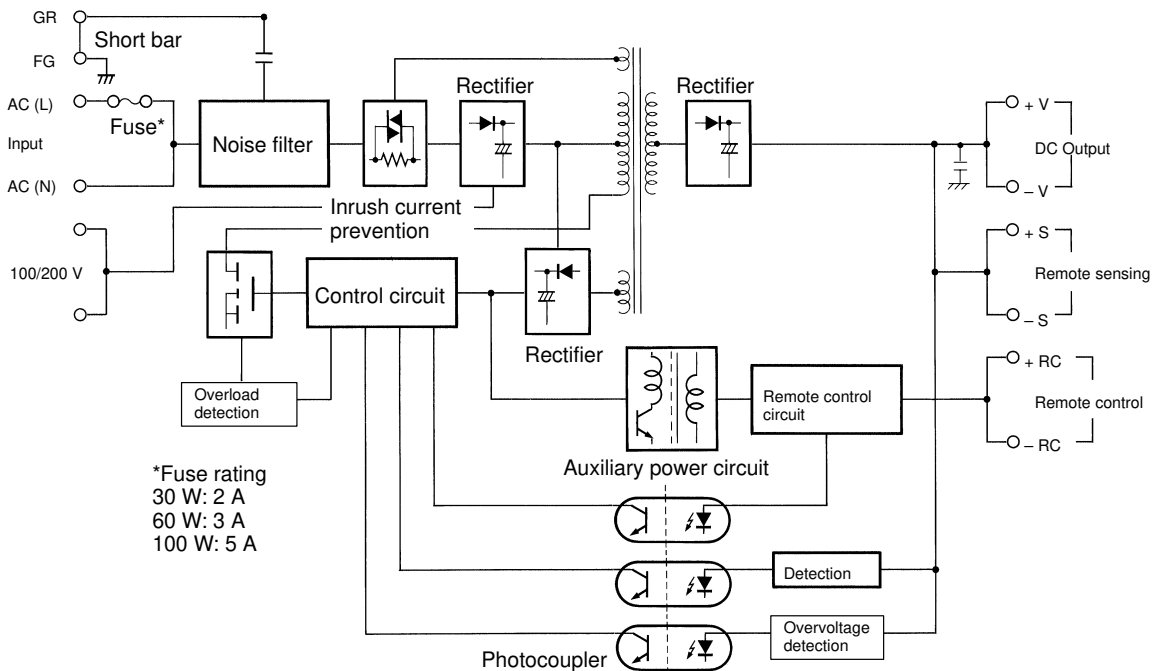

S82L-15□□ (150 W)

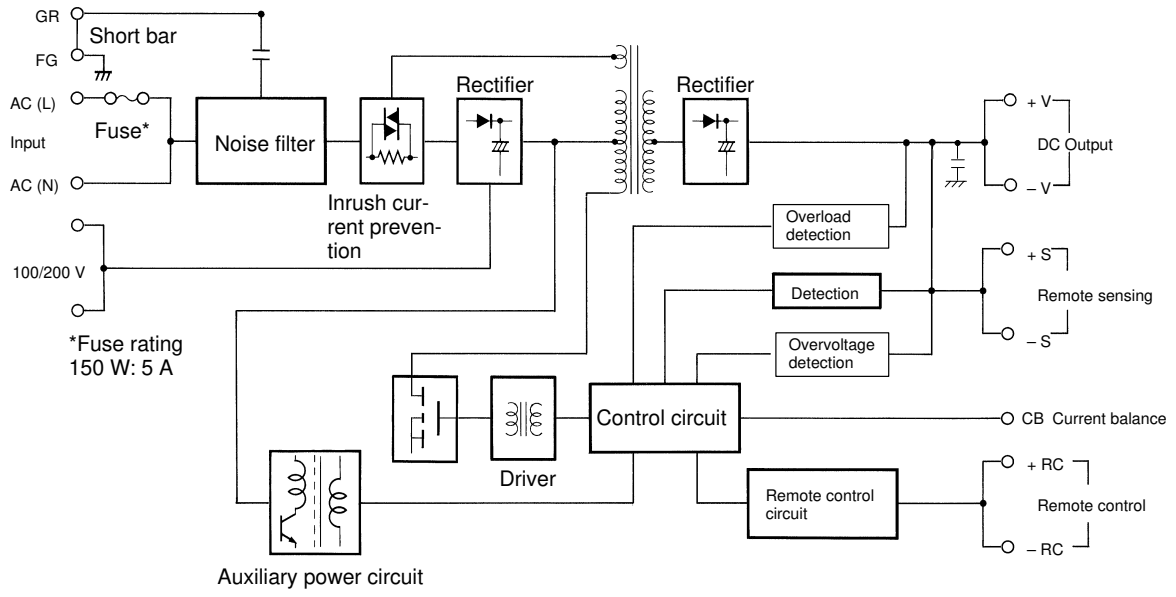

Dimensions

Note: All units are in millimeters unless otherwise indicated.

S82L-03 (30 W)

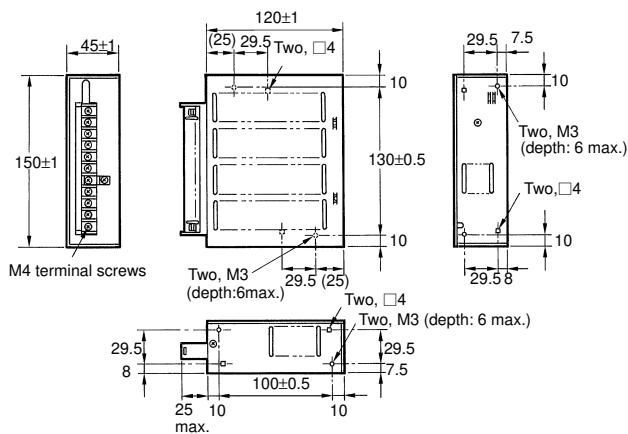
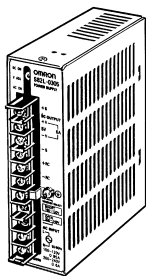

S82L-06 (60 W)

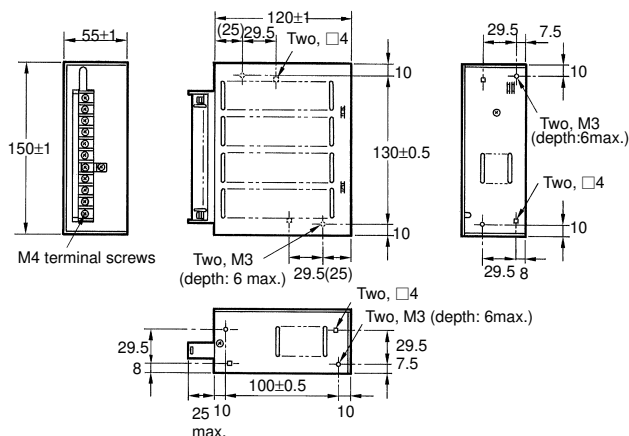
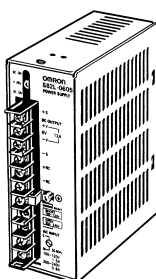

S82L-10 (100 W)

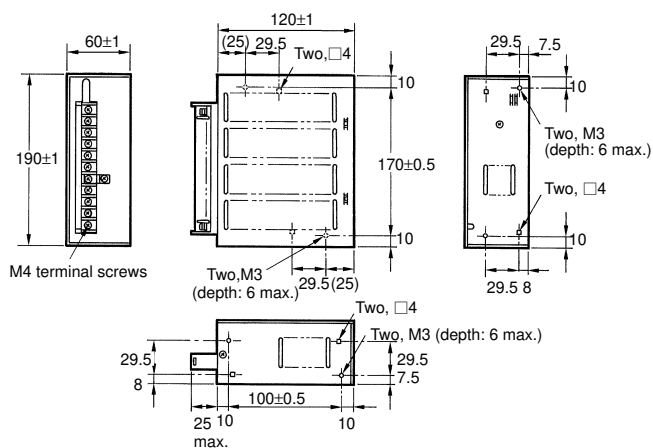
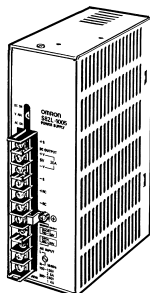

S82L-15□□ (150 W)

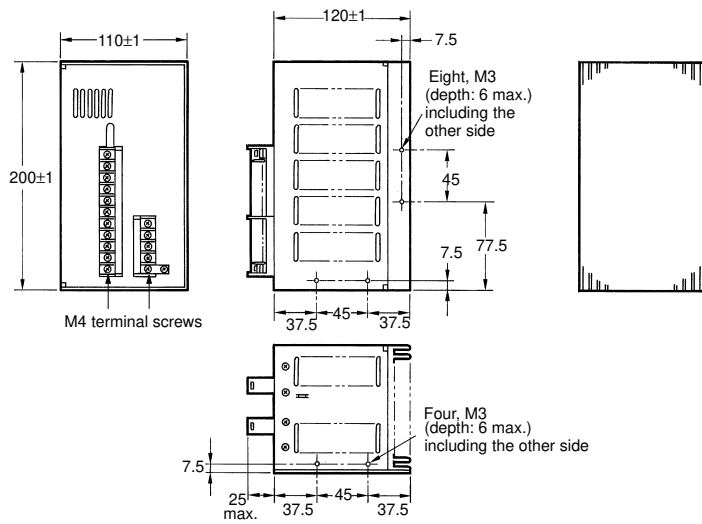
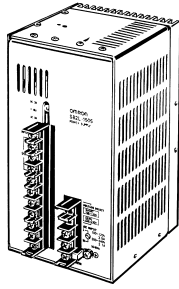

Mounting Bracket: 30/60/100 W
Bottom-mounting

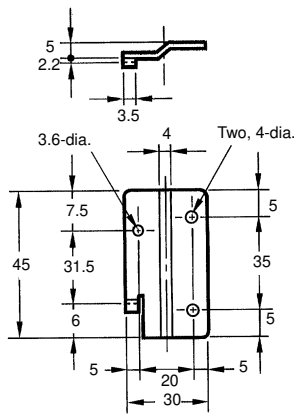
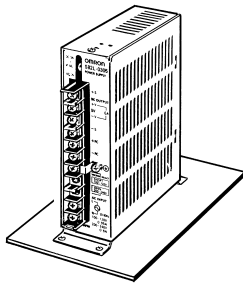

Mounting Holes

30 W: 46 max.
60 W: 56 max.
100 W: 61 max.

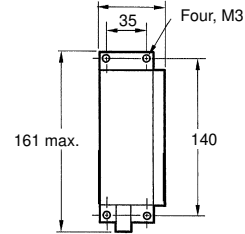

Front-mounting

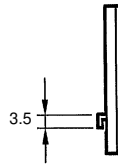
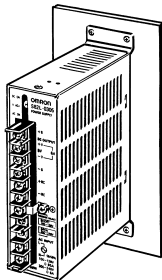

30 W: 46 max.
60 W: 56 max.
100 W: 61 max.

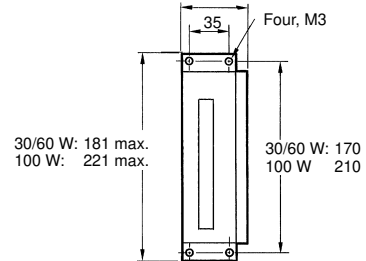

Side-mounting

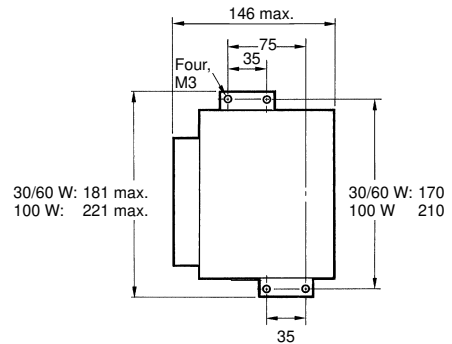
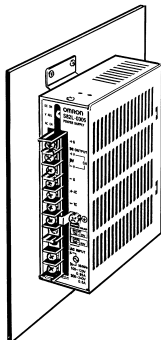

Mounting Bracket: 150 W
Bottom-mounting

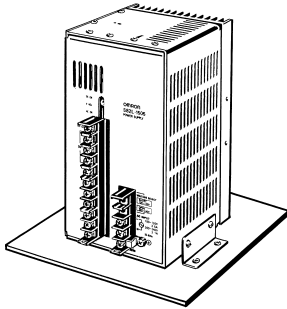

Front-mounting

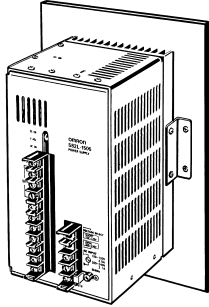

Side-mounting

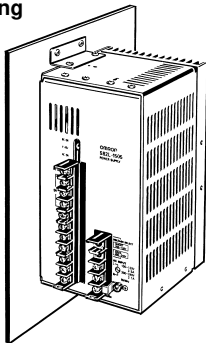

Mounting Holes

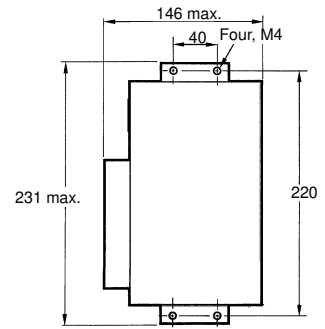
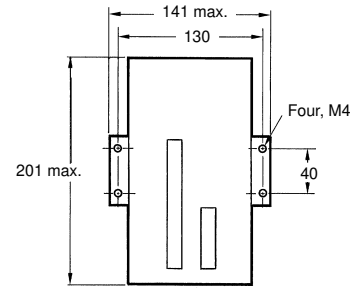
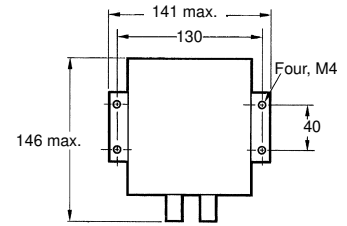
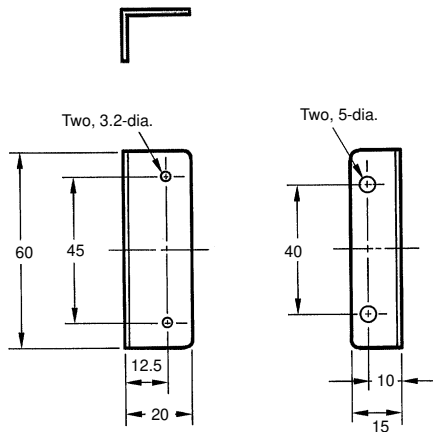

Note: The Power Supply will be separated from the mounting surface by 5 mm when the Mounting Brackets are used.

Installation

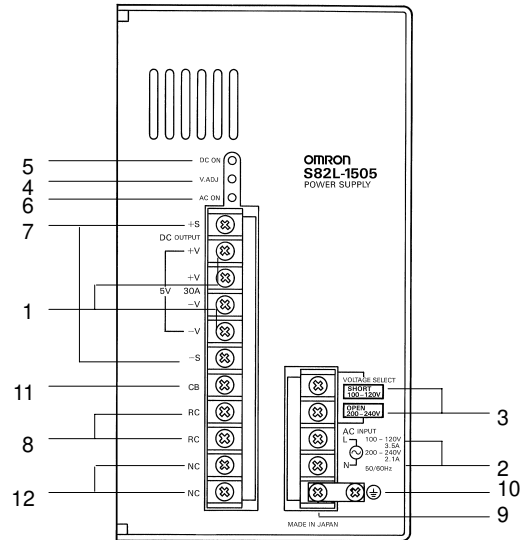
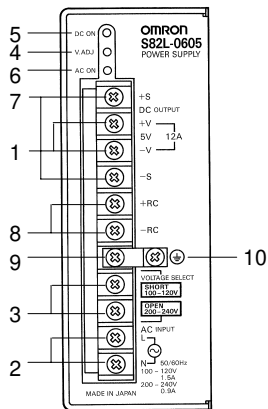

1. **DC Output Terminals:** Connect load wiring.
2. **Input Terminals:** Connect input wiring.
3. **Voltage Select Terminals:** Switch the input voltage by connecting or removing the short bar.
(short circuited: 100 to 120 V; open: 200 to 240 V)
4. **V. ADJ Adjuster:** Use to adjust the output voltage.
5. **Output LED Indicator:** Lights when DC current is being output.
6. **Input LED Indicator:** Lights when input is supplied.
7. **Remote Sensing Terminals:** Correct the voltage drop in the load lines. Shorted for normal operation.
8. **Remote Control Terminals:** Connected to an external device to enable remote control of the output while the input voltage is being applied.
9. **ACG Terminal:** The intermediate point of the input filter. Shorted to FG terminal for normal operation.
10. **FG Terminal:** Shorted to the housing, and connected to a ground line.
11. **Current Balance Terminal:** Connected to the CB terminal of another Power Supply wired in parallel.
12. **NC Terminals:** Leave unconnected.

Precautions

Mounting

Providing adequate cooling when installing the Power Supply will extend its long-term reliability.

As shown in the diagram below, the Power Supply is cooled by natural air currents, so install the unit in a location with adequate air flow.

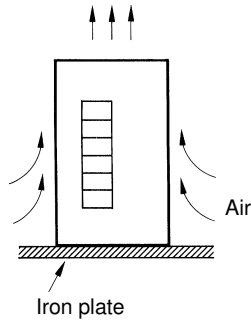

It is recommended to install the Power Supply on a metal plate, and to use forced air cooling. When installing two or more Power Supplies side-by-side, allow at least 20 mm spacing between them, as shown in the diagram below.

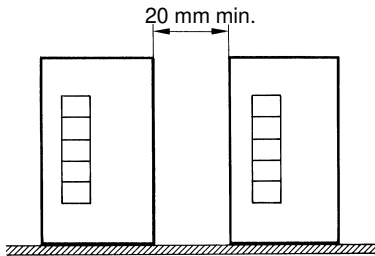

Switching the Input Voltage between 100 to 120 V and 200 to 240 V

Select 100 to 120 V or 200 to 240 V input voltage by shorting or opening the input voltage switching terminals, as shown in the diagram below. (Factory set to 200 to 240 V operation.)

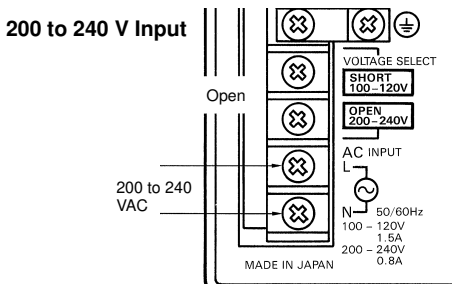
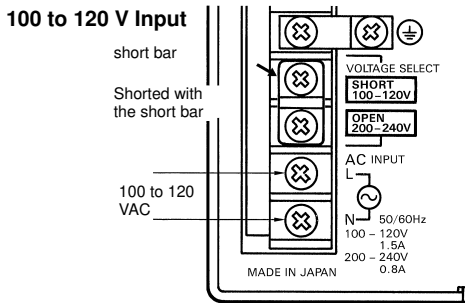

Generating Output Voltages (±)

S82L Power Supplies may be connected to provide floating output voltages (±) as shown below.

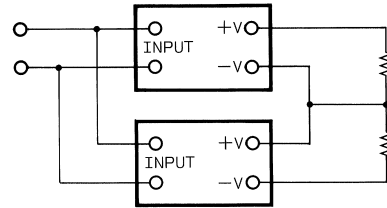

Series Connection

The output of two Power Supplies can be combined in series to double the output voltage as shown below.

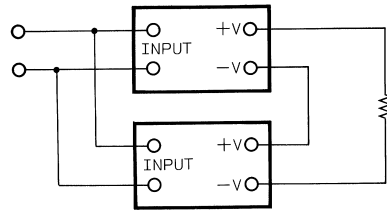

Parallel Connection (Master/Slave Operation)

The model S82L Power Supply has a built-in current balance function, allowing two units to be connected in parallel (master/slave operation) increasing the output current.

Master/Slave Operation

When connecting two Power Supplies for master/slave operation, use shielded wire to connect the current balance (CB) and -S terminals as shown below.

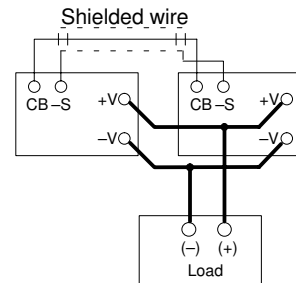

In master/slave operation, the Power Supply with the lower voltage adjustment set value (controlled by V. ADJ) is the master unit, and the Power Supply with the higher voltage adjustment set value is the slave unit.

NOTICE

A maximum of two units can be connected in parallel.

Wiring

Use high capacity wiring between the Power Supplies and the load in order to minimize voltage drops due to wire resistance. A parallel connection kit (sold separately) is available. The kit includes a bar to connect the outputs, and shielded wire to connect the current balance and -S terminals.

Connection kit	S82Y-L15A
----------------	-----------

To ensure that the voltage drop is the same between each Power Supply and load, the length and cross sectional area of the wires used should be uniform, and the system should be wired as in figure below.

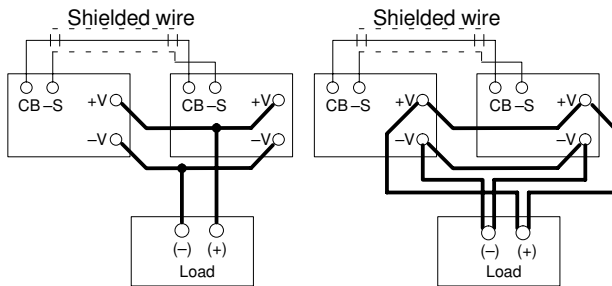

Do not wire the Power Supplies as shown below. It will cause output voltage imbalance, so that one of the units will supply exceeding current, causing the overload protection to engage, resulting in an unstable current and reducing product life expectancy.

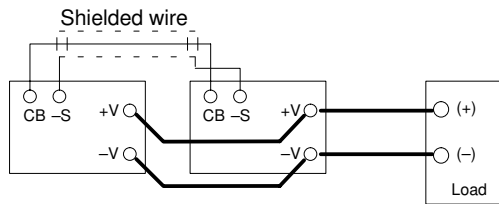

Attaching Mounting Brackets

30/60/100 W

Insert the hook on the corner of the bracket into the hole provided in the Power Supply housing. First, attach the bracket to the unit with one screw and then install the unit.

150 W

Insert the hook on the corner of the bracket into the hole provided in the Power Supply housing. Screw in both screws for each bracket and install the unit.

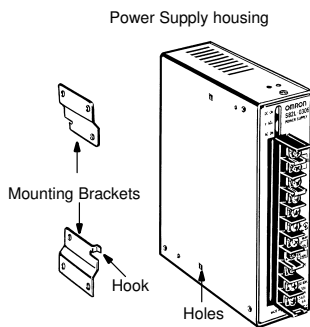

ALL DIMENSIONS SHOWN ARE IN MILLIMETERS.

To convert millimeters into inches, multiply by 0.03937. To convert grams into ounces, multiply by 0.03527.

Adjusting the Output Voltage

Follow the procedure below when adjusting the output voltage of a master/slave system.

1. Connect the two Power Supplies in parallel and decide which unit will be the master.
2. Turn the voltage adjuster (V. ADJ) of the slave unit all the way clockwise.
3. Adjust the voltage adjuster (V. ADJ) of the master unit to the desired voltage.
4. Slowly turn the voltage adjuster (V. ADJ) of the slave unit counterclockwise and set value just before output voltage drop.

NOTICE

1. It is recommended to set equal output voltages to both Power Supplies for safety reasons. If the master Power Supply stops operation by input failure or breakage, the set output value of the slave Power Supply will be output.
2. Even if one Power Supply fails to operate, both output LED indicators may be lit if the other Power Supply is in operation.
3. 30, 60, and 100 W type Power Supplies cannot perform parallel operation as they are not provided with Current Balance Function.
4. Be sure to use shielded wires when connecting CB and -S terminals to prevent noise interference with operation.

OMRON Corporation

Systems Components Division
28th Fl., Crystal Tower Bldg.
1-2-27, Shiromi, Chuo-ku,
Osaka 540 Japan
Phone: 06-949-6012 Fax: 06-949-6021