



Chipsmall Limited consists of a professional team with an average of over 10 year of expertise in the distribution of electronic components. Based in Hongkong, we have already established firm and mutual-benefit business relationships with customers from,Europe,America and south Asia,supplying obsolete and hard-to-find components to meet their specific needs.

With the principle of “Quality Parts,Customers Priority,Honest Operation,and Considerate Service”,our business mainly focus on the distribution of electronic components. Line cards we deal with include Microchip,ALPS,ROHM,Xilinx,Pulse,ON,Everlight and Freescale. Main products comprise IC,Modules,Potentiometer,IC Socket,Relay,Connector.Our parts cover such applications as commercial,industrial, and automotives areas.

We are looking forward to setting up business relationship with you and hope to provide you with the best service and solution. Let us make a better world for our industry!



Contact us

Tel: +86-755-8981 8866 Fax: +86-755-8427 6832

Email & Skype: info@chipsmall.com Web: www.chipsmall.com

Address: A1208, Overseas Decoration Building, #122 Zhenhua RD., Futian, Shenzhen, China



Evaluation Kit for SA56EX

INTRODUCTION

The EK22 evaluation kit is designed to provide a convenient way to breadboard design ideas for the SA56 PWM amplifiers. The EVAL25 evaluation board is pre-wired for all required and recommended external components. The EVAL25 also includes a breadboard area for constructing your application circuit including provisions for an output filter. Please refer to applications note 32 in the Apex catalog for guidance in filter component selection. The 1 μ F ceramic capacitors supplied with the kit are for high frequency bypassing of the VS and VDD supplies (C1 – C3 on the EVAL25 board). An additional user supplied low ESR capacitor of at least 10 μ F per amp of output current is required for adequate bypass of the VS supply (C4 on the EVAL25 board). Please refer to applications note 30 for help with power supply bypassing and other useful information.

SPECIAL CONSIDERATIONS

This kit is supplied with four schottky diodes, p/n SB5100, for use as external flyback diodes (D1 – D4). It is recommended that diodes D1 – D4 be used regardless of the mode of operation especially for high current applications. The SCin pin requires a 22-68 pF bypass capacitor to reduce the effects of switching noise on internal SC detect.

BEFORE YOU GET STARTED

- All Apex amplifiers should be handled using proper ESD precautions.
- Do not change connections while the circuit is powered.
- Initially set all power supplies to the minimum operating voltage allowed in the device data sheet.
- The power supply turn on sequence for the SA56 is VS supply on first followed by the VDD supply. If VDD is turned on before VS, the SA56 will start up in a fault condition that can not be reset until VS is greater then 12V.

FIGURE 1 - SCHEMATIC

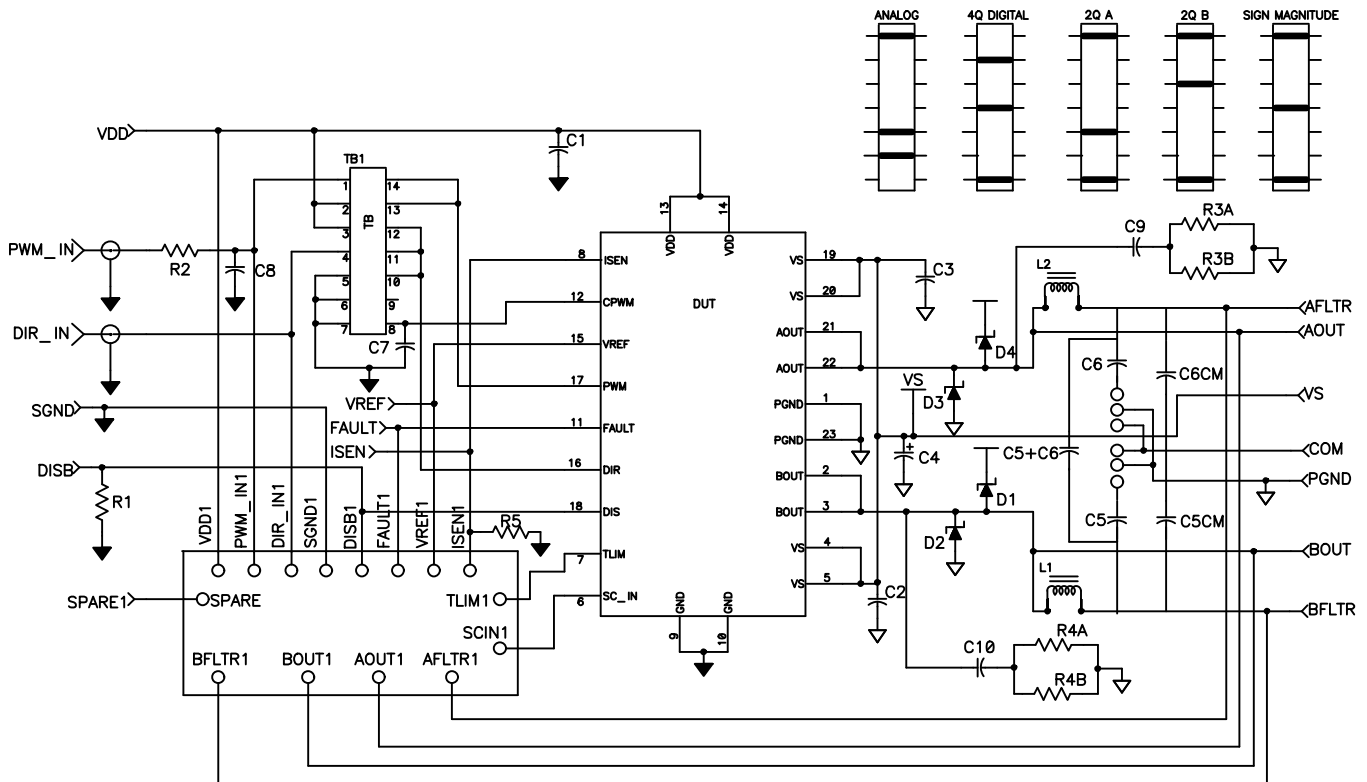

PARTS LIST

Ref. Des	Apex P/N	Description/Vendor	Qty.
NA	HS32	Heat Sink	1
NA	CLAMP05	Clip	1
NA	MS11	Strip of 30 Cage Jacks	1
NA	EVAL25	PC board	1
Various	571-0100	Banana Jack, Blk, Deltron 571-0100	2
	571-0500	Banana Jack, Red, Deltron 571-0500	2
	571-0600	Banana Jack, Wht, Deltron 571-0600	8
BN1, 2	146510CJ	BNC, PCB mount R/A, Jameco 146510CJ	2
C1-3	OX7R105KWN	1 μ F cap, Novacap 1825B105K201N	3
D1-4	SB5100	Diode, 100V, 5A	4
TB1	PTC07DAAN	Header 2x7 pin	1
J1-3	STC02SYAN	Jumper, shorting	3
NA	TW12	Thermal Washer	1 box

OPTIONAL COMPONENTS

C9, 10	C062K153K1X5CA	15 nF cap	2
R3a-4b	286-20	Resistor, 20 ohm, 5W	4

ASSEMBLY

During assembly, refer to Figures 1 & 2 and the SA56 data sheet.

- Note that each side of the circuit board is identified as either the “component side” or “bottom side”. The component side is labeled on the silk screen side of the board.
- Cut the MS11 into strips of 12 and 11. Discard the remaining small strip. Insert the two strips into the two rows of holes for the SA56 from the component side of the PCB. From the bottom side, solder all cage jacks to the circuit board pads. Be sure that the cage jacks are fully seated before soldering. Be careful that the solder does not flow into the cage jack. Remove the plastic carrier strips.
- Solder the surface mount capacitors at C1 – C3, on the component side of the PCB. The carrier strips removed from the cage jacks in step 2 are convenient as a tool to hold the capacitors in place while soldering. The carrier strips can be discarded when no longer needed for this purpose. Though not required, it is a good idea to fill in the vias on the PGND side of C2 and C3 with solder.
- From the component side, insert the 4 diodes D1 – D4 into the PCB at the locations marked on the board. Solder the diodes to the PCB from the bottom side.
- Insert the 14 pin header TB1 into the PCB from the component side. Solder TB1 from the bottom side. Install shorting jumpers J1 – J3 on TB1 to configure the mode of operation for the SA56. Refer to the schematic in figure 2 for jumper positions. The top pair of pins in the schematic diagram for TB1 correspond to the left most pair of pins when TB1 is viewed on the PCB in figure 3.
- Mount the banana jacks and the BNC connectors to the PCB at locations marked on the PCB as needed or as desired. Solder these from the bottom side of the board.
- Mount an electrolytic bypass capacitor (not supplied) at C4 from the component side of the PCB. Match the polarity markings on the PCB. Solder the capacitor to the PCB from the bottom side.
- The SA56 will not function with the ISEN pin open. Select a resistor value and install on the component side of the PCB between ISEN and SGND at the R5 position marked on the PCB. Solder from the bottom side. If a current limit resistor is not used, short the ISEN pads to SGND in place of R5.
- It is recommended that a 10K to 20K pull down resistor be installed between the disable line and SGND at the location labeled R1. For reliable start-up it is recommended to include a capacitor and diode to VDD as shown in figure 1.
- For analog mode operation, a PWM timing capacitor is required. Refer to the SA56 datasheet for timing capacitor calculation. Install the timing capacitor in the C7 location.
- Install the snubber components C9, R3a, R3b and C10, R4a, R4b at the locations labeled on the PCB.

12. If the prototype SA56 will be used in an analog application it is recommended to include an input RC filter in series with the PWM_IN input (R2 and C8). The PWM_IN BNC connector is not routed to the SA56 unless a resistor or a shorting wire is installed at the R2 location.
13. Mount other components to complete your application circuit, using the pads and holes provided. Trim all excess leads.
14. The PCB has provisions for a 2 pole output filter. The locations for the inductors L1 and L2 are designed to accept a wide range of sizes for either a through hole or surface mount style of inductor. J.W. Miller series 6700 through hole inductors or series PM2110 surface mount inductors will fit in these locations and include a wide range of inductors suitable for many SA56 applications. These inductors are readily available from Digikey Corp.
15. Place a TW12 thermal washer between the SA56 and the heatsink. Attach the SA56 to the heatsink using the CLAMP05 clip. Insert the SA56 leads into the cage jacks from the component side of the PCB.
16. Secure the HS32 to the board with two 6-32 self tapping screws (Not supplied) through the elongated holes in the board from the bottom side.
17. Hook up power and signals as necessary. The amplifier is now ready for testing.



FIGURE 2 - PCB

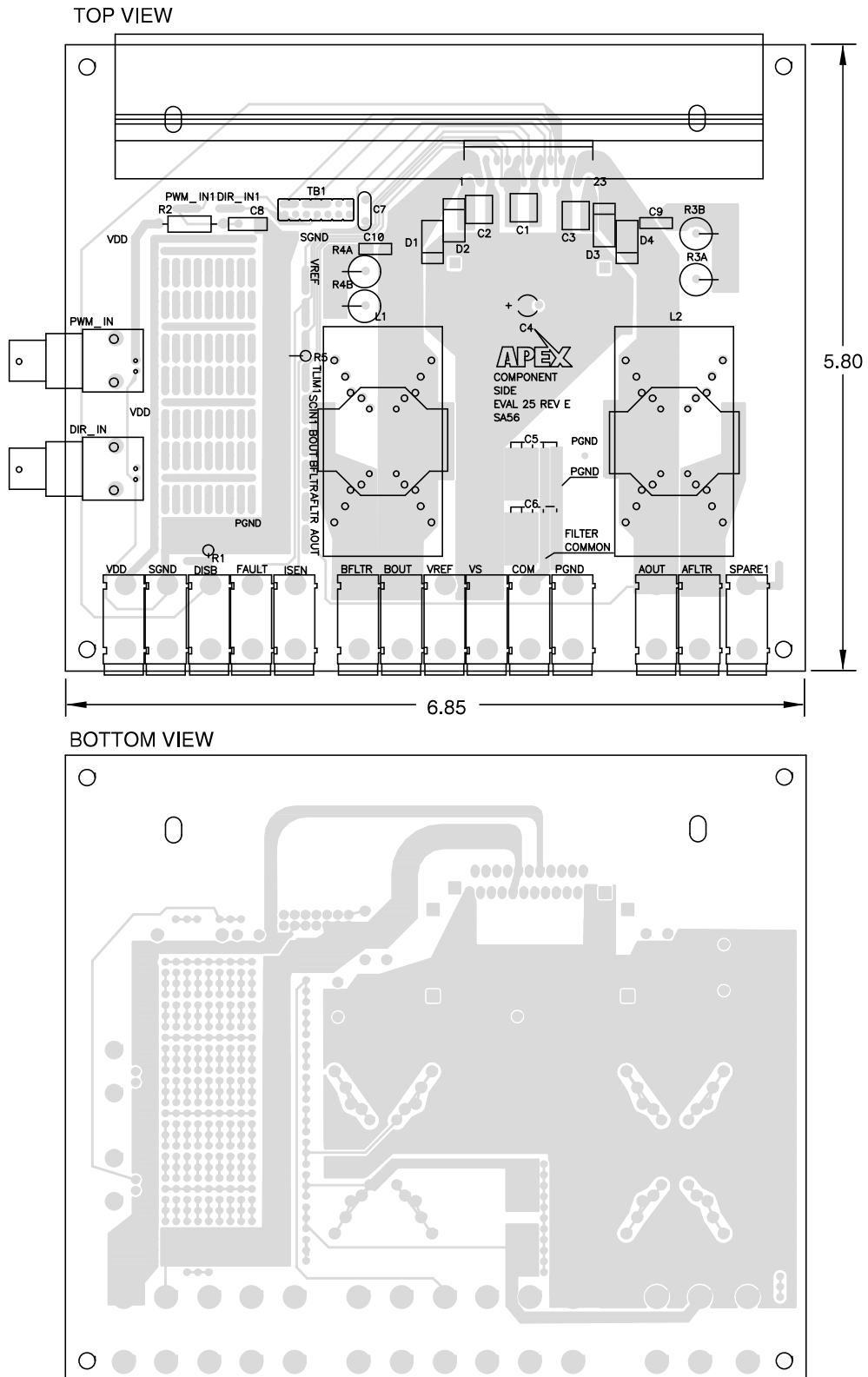



CONTACTING CIRRUS LOGIC SUPPORT

For all Apex Precision Power product questions and inquiries call toll free 800-546-2739 in North America. For International customer support, contact a local Cirrus Logic Sales Representative.

To find the one nearest to you, go to <http://www.cirrus.com>

IMPORTANT NOTICE

Cirrus Logic, Inc. and its subsidiaries ("Cirrus") believe that the information contained in this document is accurate and reliable. However, the information is subject to change without notice and is provided "AS IS" without warranty of any kind (express or implied). Customers are advised to obtain the latest version of relevant information to verify, before placing orders, that information being relied on is current and complete. All products are sold subject to the terms and conditions of sale supplied at the time of order acknowledgment, including those pertaining to warranty, indemnification, and limitation of liability. No responsibility is assumed by Cirrus for the use of this information, including use of this information as the basis for manufacture or sale of any items, or for infringement of patents or other rights of third parties. This document is the property of Cirrus and by furnishing this information, Cirrus grants no license, express or implied under any patents, mask work rights, copyrights, trademarks, trade secrets or other intellectual property rights. Cirrus owns the copyrights associated with the information contained herein and gives consent for copies to be made of the information only for use within your organization with respect to Cirrus integrated circuits or other products of Cirrus. This consent does not extend to other copying such as copying for general distribution, advertising or promotional purposes, or for creating any work for resale.

CERTAIN APPLICATIONS USING SEMICONDUCTOR PRODUCTS MAY INVOLVE POTENTIAL RISKS OF DEATH, PERSONAL INJURY, OR SEVERE PROPERTY OR ENVIRONMENTAL DAMAGE ("CRITICAL APPLICATIONS"). CIRRUS PRODUCTS ARE NOT DESIGNED, AUTHORIZED OR WARRANTED TO BE SUITABLE FOR USE IN PRODUCTS SURGICALLY IMPLANTED INTO THE BODY, AUTOMOTIVE SAFETY OR SECURITY DEVICES, LIFE SUPPORT PRODUCTS OR OTHER CRITICAL APPLICATIONS. INCLUSION OF CIRRUS PRODUCTS IN SUCH APPLICATIONS IS UNDERSTOOD TO BE FULLY AT THE CUSTOMER'S RISK AND CIRRUS DISCLAIMS AND MAKES NO WARRANTY, EXPRESS, STATUTORY OR IMPLIED, INCLUDING THE IMPLIED WARRANTIES OF MERCHANTABILITY AND FITNESS FOR PARTICULAR PURPOSE, WITH REGARD TO ANY CIRRUS PRODUCT THAT IS USED IN SUCH A MANNER. IF THE CUSTOMER OR CUSTOMER'S CUSTOMER USES OR PERMITS THE USE OF CIRRUS PRODUCTS IN CRITICAL APPLICATIONS, CUSTOMER AGREES, BY SUCH USE, TO FULLY INDEMNIFY CIRRUS, ITS OFFICERS, DIRECTORS, EMPLOYEES, DISTRIBUTORS AND OTHER AGENTS FROM ANY AND ALL LIABILITY, INCLUDING ATTORNEYS' FEES AND COSTS, THAT MAY RESULT FROM OR ARISE IN CONNECTION WITH THESE USES.

Cirrus Logic, Cirrus, and the Cirrus Logic logo designs, Apex and Apex Precision Power are trademarks of Cirrus Logic, Inc. All other brand and product names in this document may be trademarks or service marks of their respective owners.