



Chipsmall Limited consists of a professional team with an average of over 10 year of expertise in the distribution of electronic components. Based in Hongkong, we have already established firm and mutual-benefit business relationships with customers from,Europe,America and south Asia,supplying obsolete and hard-to-find components to meet their specific needs.

With the principle of “Quality Parts,Customers Priority,Honest Operation,and Considerate Service”,our business mainly focus on the distribution of electronic components. Line cards we deal with include Microchip,ALPS,ROHM,Xilinx,Pulse,ON,Everlight and Freescale. Main products comprise IC,Modules,Potentiometer,IC Socket,Relay,Connector.Our parts cover such applications as commercial,industrial, and automotives areas.

We are looking forward to setting up business relationship with you and hope to provide you with the best service and solution. Let us make a better world for our industry!



Contact us

Tel: +86-755-8981 8866 Fax: +86-755-8427 6832

Email & Skype: info@chipsmall.com Web: www.chipsmall.com

Address: A1208, Overseas Decoration Building, #122 Zhenhua RD., Futian, Shenzhen, China



DATA SHEET

SA605

High performance low power mixer FM IF system

Product specification
Replaces data of November 3, 1992
RF Communications Handbook

1997 Nov 07

Philips Semiconductors



PHILIPS

High performance low power mixer FM IF system

SA605

DESCRIPTION

The SA605 is a high performance monolithic low-power FM IF system incorporating a mixer/oscillator, two limiting intermediate frequency amplifiers, quadrature detector, muting, logarithmic received signal strength indicator (RSSI), and voltage regulator. The SA605 combines the functions of Signetics' SA602 and SA604A, but features a higher mixer input intercept point, higher IF bandwidth (25MHz) and temperature compensated RSSI and limiters permitting higher performance application. The SA605 is available in 20-lead dual-in-line plastic, 20-lead SOL (surface-mounted miniature package) and 20-lead SSOP (shrink small outline package).

The SA605 and SA615 are functionally the same device types. The difference between the two devices lies in the guaranteed specifications. The SA615 has a higher I_{CC}, lower input third order intercept point, lower conversion mixer gain, lower limiter gain, lower AM rejection, lower SINAD, higher THD, and higher RSSI error than the SA605. Both the SA605 and SA615 devices will meet the EIA specifications for AMPS and TACS cellular radio applications.

For additional technical information please refer to application notes AN1994, 1995 and 1996, which include example application diagrams, a complete overview of the product, and artwork for reference.

APPLICATIONS

- Cellular radio FM IF
- High performance communications receivers
- Single conversion VHF/UHF receivers
- SCA receivers
- RF level meter
- Spectrum analyzer
- Instrumentation
- FSK and ASK data receivers
- Log amps
- Wideband low current amplification

PIN CONFIGURATION

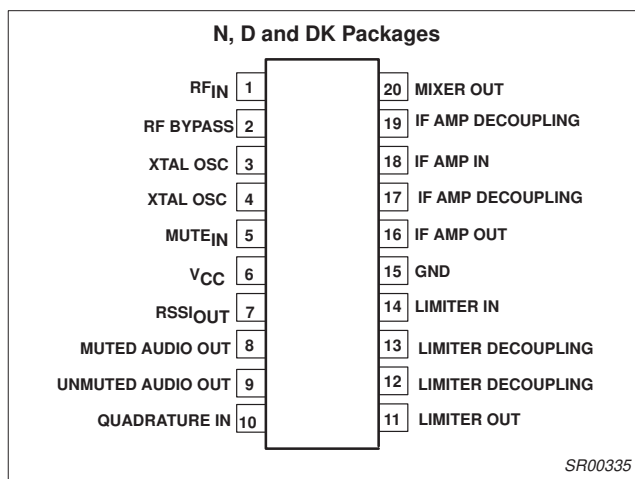

Figure 1. Pin Configuration

FEATURES

- Low power consumption: 5.7mA typical at 6V
- Mixer input to >500MHz
- Mixer conversion power gain of 13dB at 45MHz
- Mixer noise figure of 4.6dB at 45MHz
- XTAL oscillator effective to 150MHz (L.C. oscillator to 1GHz local oscillator can be injected)
- 102dB of IF Amp/Limiter gain
- 25MHz limiter small signal bandwidth
- Temperature compensated logarithmic Received Signal Strength Indicator (RSSI) with a dynamic range in excess of 90dB
- Two audio outputs - muted and unmuted
- Low external component count; suitable for crystal/ceramic/LC filters
- Excellent sensitivity: 0.22µV into 50Ω matching network for 12dB SINAD (Signal to Noise and Distortion ratio) for 1kHz tone with RF at 45MHz and IF at 455kHz
- SA605 meets cellular radio specifications
- ESD hardened

ORDERING INFORMATION

DESCRIPTION	TEMPERATURE RANGE	ORDER CODE	DWG #
20-Pin Plastic Dual In-Line Package (DIP)	-40 to +85°C	SA605N	SOT146-1
20-Pin Plastic Small Outline Large (SOL) package	-40 to +85°C	SA605D	SOT163-1
20-Pin Plastic Shrink Small Outline Package (SSOP)	-40 to +85°C	SA605DK	SOT266-1

High performance low power mixer FM IF system

SA605

BLOCK DIAGRAM

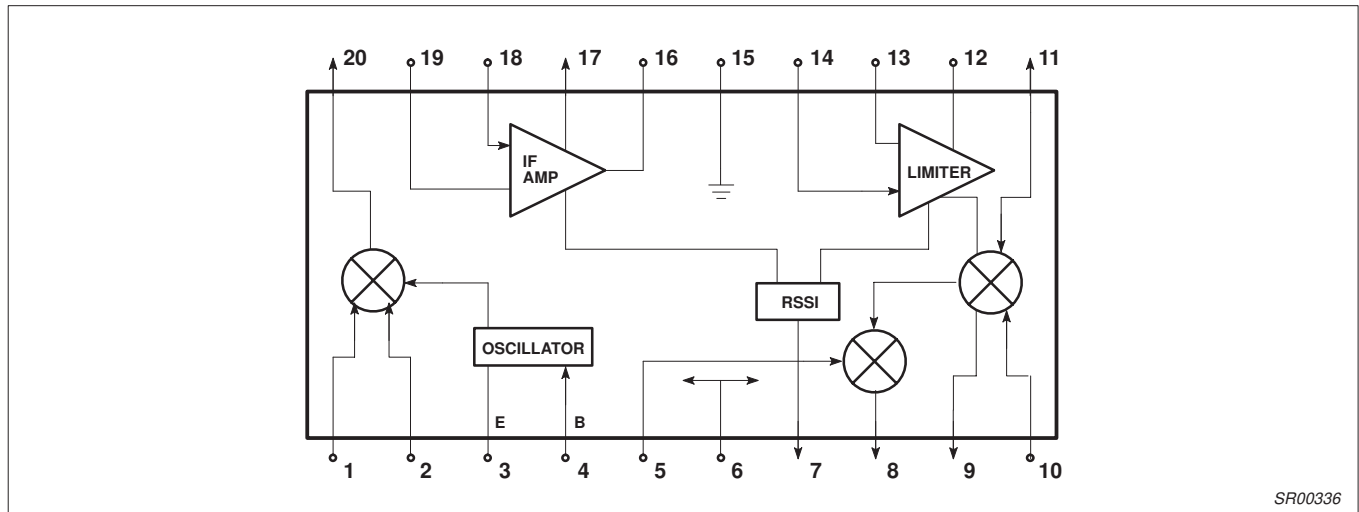

Figure 2. Block Diagram

SR00336

ABSOLUTE MAXIMUM RATINGS

SYMBOL	PARAMETER	RATING	UNITS
V_{CC}	Single supply voltage	9	V
T_{STG}	Storage temperature range	-65 to +150	°C
T_A	Operating ambient temperature range SA605	-40 to +85	°C
θ_{JA}	Thermal impedance D package N package SSOP package	90 75 117	°C/W

DC ELECTRICAL CHARACTERISTICS

$V_{CC} = +6V$, $T_A = 25^\circ C$; unless otherwise stated.

SYMBOL	PARAMETER	TEST CONDITIONS	LIMITS			UNITS
			SA605			
			MIN	TYP	MAX	
V_{CC}	Power supply voltage range		4.5		8.0	V
I_{CC}	DC current drain		4.55	5.7	6.55	mA
	Mute switch input threshold (ON)		1.7			V
	(OFF)				1.0	V

High performance low power mixer FM IF system

SA605

AC ELECTRICAL CHARACTERISTICS

$T_A = 25^\circ\text{C}$; $V_{CC} = +6\text{V}$, unless otherwise stated. RF frequency = 45MHz + 14.5dBV RF input step-up; IF frequency = 455kHz; $R_{17} = 5.1\text{k}$; RF level = -45dBm; FM modulation = 1kHz with $\pm 8\text{kHz}$ peak deviation. Audio output with C-message weighted filter and de-emphasis capacitor. Test circuit Figure 3. The parameters listed below are tested using automatic test equipment to assure consistent electrical characteristics. The limits do not represent the ultimate performance limits of the device. Use of an optimized RF layout will improve many of the listed parameters.

SYMBOL	PARAMETER	TEST CONDITIONS	LIMITS			UNITS
			SA605			
			MIN	TYP	MAX	
Mixer/Osc section (ext LO = 300mV)						
f_{IN}	Input signal frequency			500		MHz
f_{OSC}	Crystal oscillator frequency			150		MHz
	Noise figure at 45MHz			5.0		dB
	Third-order input intercept point	$f_1 = 45.0$; $f_2 = 45.06\text{MHz}$		-10		dBm
	Conversion power gain	Matched 14.5dBV step-up	10	13	15	dB
		50 Ω source		-1.7		dB
	RF input resistance	Single-ended input	3.0	4.7		k Ω
	RF input capacitance			3.5	4.0	pF
	Mixer output resistance	(Pin 20)	1.25	1.5		k Ω
IF section						
	IF amp gain	50 Ω source		39.7		dB
	Limiter gain	50 Ω source		62.5		dB
	Input limiting -3dB, $R_{17} = 5.1\text{k}$	Test at Pin 18		-113		dBm
	AM rejection	80% AM 1kHz	29	34	43	dB
	Audio level, $R_{10} = 100\text{k}$	15nF de-emphasis	80	150	260	mV _{RMS}
	Unmuted audio level, $R_{11} = 100\text{k}$	150pF de-emphasis		480		mV
	SINAD sensitivity	RF level -118dB		16		dB
THD	Total harmonic distortion		-34	-42		dB
S/N	Signal-to-noise ratio	No modulation for noise		73		dB
	IF RSSI output, $R_9 = 100\text{k}\Omega^1$	IF level = -118dBm	0	160	650	mV
		IF level = -68dBm	1.9	2.5	3.1	V
		IF level = -18dBm	4.0	4.8	5.6	V
	RSSI range	$R_9 = 100\text{k}\Omega$ Pin 16		90		dB
	RSSI accuracy	$R_9 = 100\text{k}\Omega$ Pin 16		± 1.5		dB
	IF input impedance		1.40	1.6		k Ω
	IF output impedance		0.85	1.0		k Ω
	Limiter input impedance		1.40	1.6		k Ω
	Unmuted audio output resistance			58		k Ω
	Muted audio output resistance			58		k Ω
RF/IF section (int LO)						
	Unmuted audio level	4.5V = V_{CC} , RF level = -27dBm		450		mV _{RMS}
	System RSSI output	4.5V = V_{CC} , RF level = -27dBm		4.3		V

NOTE:

- The generator source impedance is 50 Ω , but the SA605 input impedance at Pin 18 is 1500 Ω . As a result, IF level refers to the actual signal that enters the SA605 input (Pin 8) which is about 21dB less than the "available power" at the generator.

High performance low power mixer FM IF system

SA605

CIRCUIT DESCRIPTION

The SA605 is an IF signal processing system suitable for second IF or single conversion systems with input frequency as high as 1GHz. The bandwidth of the IF amplifier is about 40MHz, with 39.7dB(v) of gain from a 50Ω source. The bandwidth of the limiter is about 28MHz with about 62.5dB(v) of gain from a 50Ω source. However, the gain/bandwidth distribution is optimized for 455kHz, 1.5kΩ source applications. The overall system is well-suited to battery operation as well as high performance and high quality products of all types.

The input stage is a Gilbert cell mixer with oscillator. Typical mixer characteristics include a noise figure of 5dB, conversion gain of 13dB, and input third-order intercept of -10dBm. The oscillator will operate in excess of 1GHz in L/C tank configurations. Hartley or Colpitts circuits can be used up to 100MHz for xtal configurations. Butler oscillators are recommended for xtal configurations up to 150MHz.

The output of the mixer is internally loaded with a 1.5kΩ resistor permitting direct connection to a 455kHz ceramic filter. The input resistance of the limiting IF amplifiers is also 1.5kΩ. With most 455kHz ceramic filters and many crystal filters, no impedance matching network is necessary. To achieve optimum linearity of the log signal strength indicator, there must be a 12dB(v) insertion loss between the first and second IF stages. If the IF filter or interstage

network does not cause 12dB(v) insertion loss, a fixed or variable resistor can be added between the first IF output (Pin 16) and the interstage network.

The signal from the second limiting amplifier goes to a Gilbert cell quadrature detector. One port of the Gilbert cell is internally driven by the IF. The other output of the IF is AC-coupled to a tuned quadrature network. This signal, which now has a 90° phase relationship to the internal signal, drives the other port of the multiplier cell.

Overall, the IF section has a gain of 90dB. For operation at intermediate frequencies greater than 455kHz, special care must be given to layout, termination, and interstage loss to avoid instability.

The demodulated output of the quadrature detector is available at two pins, one continuous and one with a mute switch. Signal attenuation with the mute activated is greater than 60dB. The mute input is very high impedance and is compatible with CMOS or TTL levels.

A log signal strength completes the circuitry. The output range is greater than 90dB and is temperature compensated. This log signal strength indicator exceeds the criteria for AMPs or TACs cellular telephone.

NOTE: $\text{dB(v)} = 20\log V_{\text{OUT}}/V_{\text{IN}}$

High performance low power mixer FM IF system

SA605

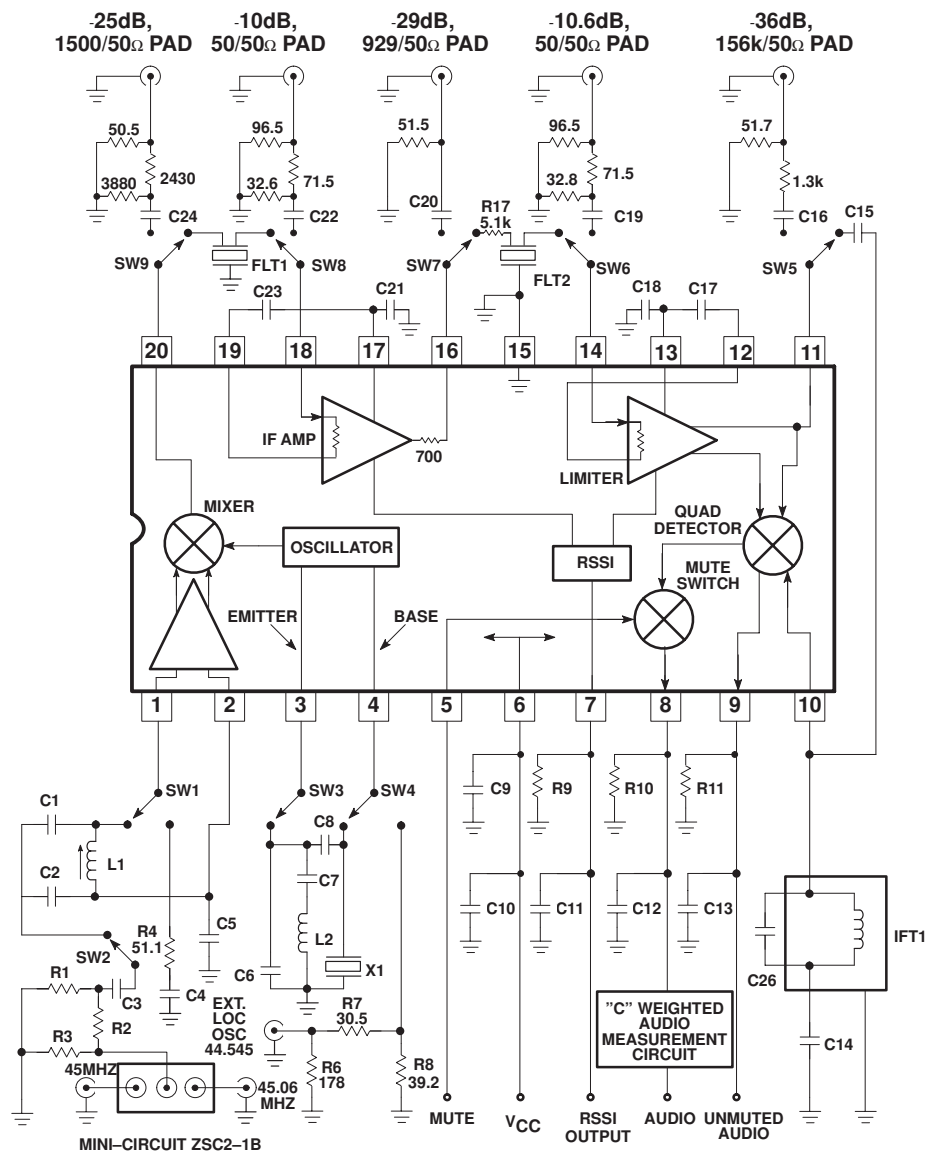

Automatic Test Circuit Component List

- | | | | |
|-----|-------------------------------|-------|---|
| C1 | 47pF NPO Ceramic | C21 | 100nF ±10% Monolithic Ceramic |
| C2 | 180pF NPO Ceramic | C23 | 100nF ±10% Monolithic Ceramic |
| C5 | 100nF ±10% Monolithic Ceramic | C25 | 100nF ±10% Monolithic Ceramic |
| C6 | 22pF NPO Ceramic | C26 | 390pF ±10% Monolithic Ceramic |
| C7 | 1nF Ceramic | Flt 1 | Ceramic Filter Murata SFG455A3 or equiv |
| C8 | 10.0pF NPO Ceramic | Flt 2 | Ceramic Filter Murata SFG455A3 or equiv |
| C9 | 100nF ±10% Monolithic Ceramic | IFT 1 | 455kHz 270μH TOKO #303LN-1129 |
| C10 | 6.8μF Tantalum (minimum) * | L1 | 300nH TOKO #5CB-1055Z |
| C11 | 100nF ±10% Monolithic Ceramic | L2 | 0.8μH TOKO 292CNS-T1038Z |
| C12 | 15nF ±10% Ceramic | X1 | 44.545MHz Crystal ICM4712701 |
| C13 | 150pF ±2% N1500 Ceramic | R9 | 100k ±1% 1/4W Metal Film |
| C14 | 100nF ±10% Monolithic Ceramic | R17 | 5.1k ±5% 1/4W Carbon Composition |
| C15 | 10pF NPO Ceramic | R10 | 100k ±1% 1/4W Metal Film (optional) |
| C17 | 100nF ±10% Monolithic Ceramic | R11 | 100k ±1% 1/4W Metal Film (optional) |
| C18 | 100nF ±10% Monolithic Ceramic | | |

* NOTE: This value can be reduced when a battery is the power source.

SR00337

Figure 3. SA605 45MHz Test Circuit (Relays as shown)

High performance low power mixer FM IF system

SA605

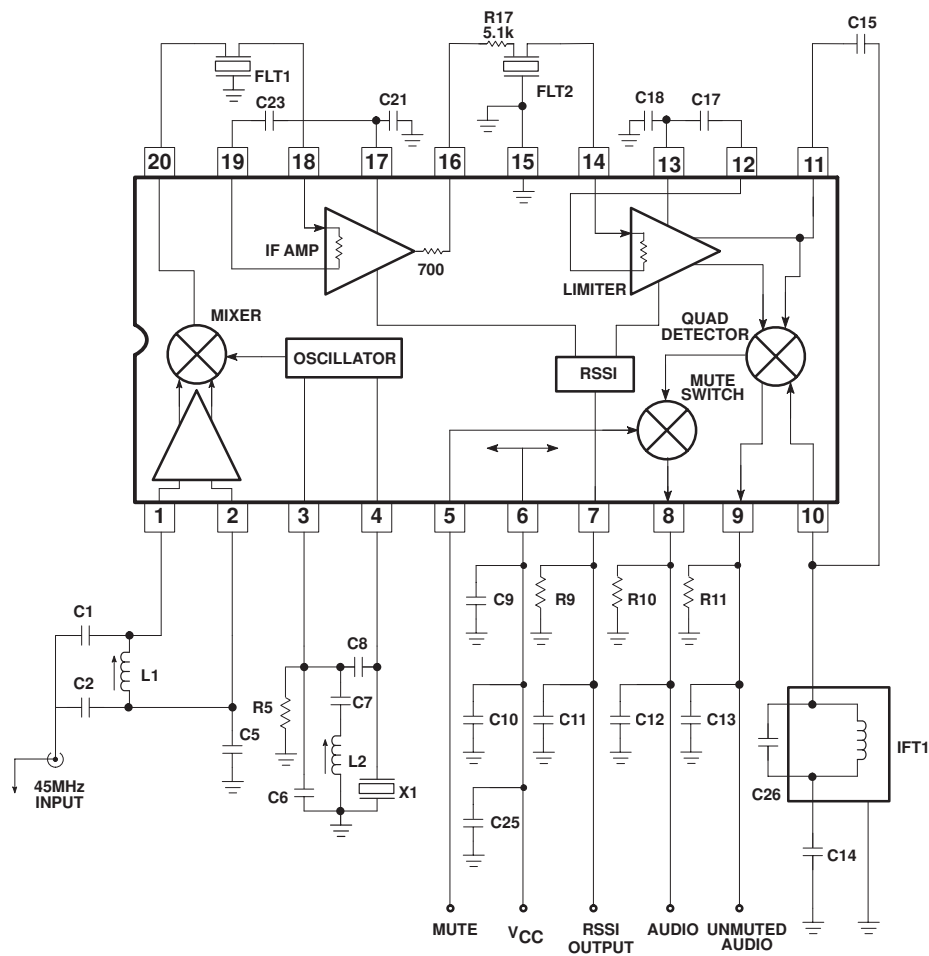

Application Component List

- | | | | |
|-----|-------------------------------|-------|---|
| C1 | 47pF NPO Ceramic | C21 | 100nF ±10% Monolithic Ceramic |
| C2 | 180pF NPO Ceramic | C23 | 100nF ±10% Monolithic Ceramic |
| C5 | 100nF ±10% Monolithic Ceramic | C25 | 100nF ±10% Monolithic Ceramic |
| C6 | 22pF NPO Ceramic | C26 | 390pF ±10% Monolithic Ceramic |
| C7 | 1nF Ceramic | Flt 1 | Ceramic Filter Murata SFG455A3 or equiv |
| C8 | 10.0pF NPO Ceramic | Flt 2 | Ceramic Filter Murata SFG455A3 or equiv |
| C9 | 100nF ±10% Monolithic Ceramic | IFT 1 | 455kHz 270µH TOKO #303LN-1129 |
| C10 | 6.8µF Tantalum (minimum) | L1 | 300nH TOKO #5CB-1055Z |
| C11 | 100nF ±10% Monolithic Ceramic | L2 | 0.8µH TOKO 292CNS-T1038Z |
| C12 | 15nF ±10% Ceramic | X1 | 44.545MHz Crystal ICM4712701 |
| C13 | 150pF ±2% N1500 Ceramic | R9 | 100k ±1% 1/4W Metal Film |
| C14 | 100nF ±10% Monolithic Ceramic | R17 | 5.1k ±5% 1/4W Carbon Composition |
| C15 | 10pF NPO Ceramic | R10 | 100k ±1% 1/4W Metal Film (optional) |
| C17 | 100nF ±10% Monolithic Ceramic | R11 | 100k ±1% 1/4W Metal Film (optional) |
| C18 | 100nF ±10% Monolithic Ceramic | | |

* NOTE: This value can be reduced when a battery is the power source.

SR00338

Figure 4. SA605 45MHz Application Circuit

High performance low power mixer FM IF system

SA605

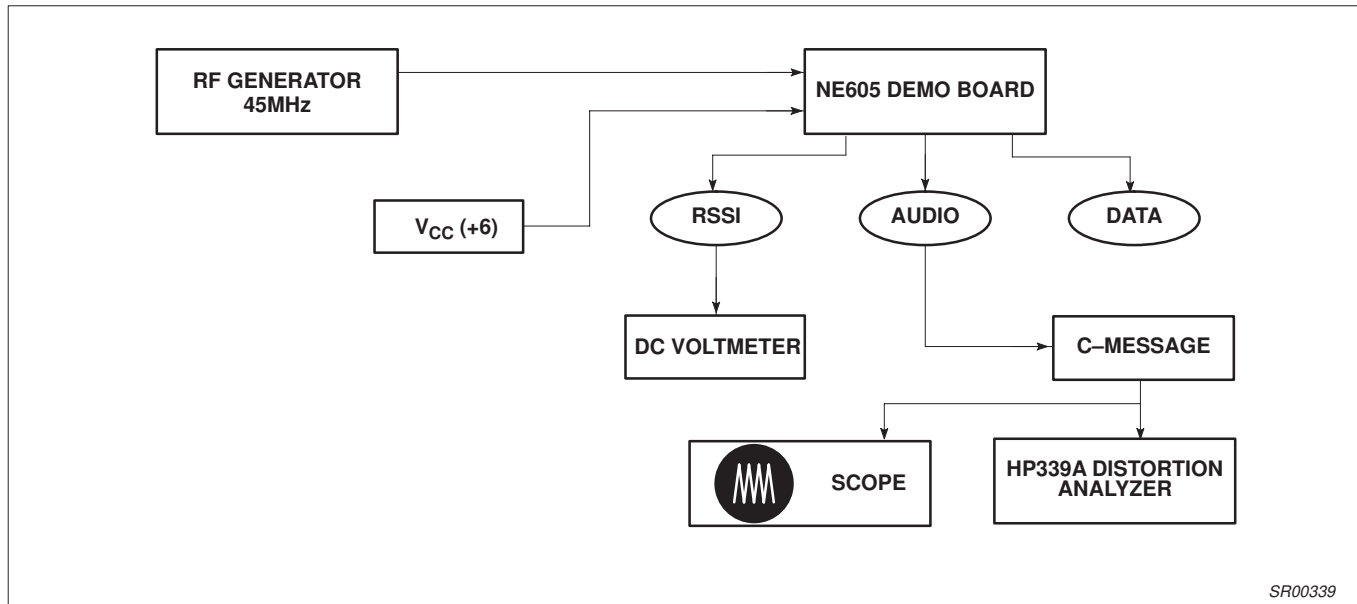

SR00339

Figure 5. SA605 Application Circuit Test Set Up

NOTES:

1. C-message: The C-message filter has a peak gain of 100 for accurate measurements. Without the gain, the measurements may be affected by the noise of the scope and HP339 analyzer.
2. Ceramic filters: The ceramic filters can be 30kHz SFG455A3s made by Murata which have 30kHz IF bandwidth (they come in blue), or 16kHz CFU455Ds, also made by Murata (they come in black). All of our specifications and testing are done with the more wideband filter.
3. RF generator: Set your RF generator at 45.000MHz, use a 1kHz modulation frequency and a 6kHz deviation if you use 16kHz filters, or 8kHz if you use 30kHz filters.
4. Sensitivity: The measured typical sensitivity for 12dB SINAD should be 0.22 μ V or -120dBm at the RF input.
5. Layout: The layout is very critical in the performance of the receiver. We highly recommend our demo board layout.
6. RSSI: The smallest RSSI voltage (i.e., when no RF input is present and the input is terminated) is a measure of the quality of the layout and design. If the lowest RSSI voltage is 250mV or higher, it means the receiver is in regenerative mode. In that case, the receiver sensitivity will be worse than expected.
7. Supply bypass and shielding: All of the inductors, the quad tank, and their shield must be grounded. A 10-15 μ F or higher value tantalum capacitor on the supply line is essential. A low frequency ESR screening test on this capacitor will ensure consistent good sensitivity in production. A 0.1 μ F bypass capacitor on the supply pin, and grounded near the 44.545MHz oscillator improves sensitivity by 2-3dB.
8. R5 can be used to bias the oscillator transistor at a higher current for operation above 45MHz. Recommended value is 22k Ω , but should not be below 10k Ω .

High performance low power mixer FM IF system

SA605

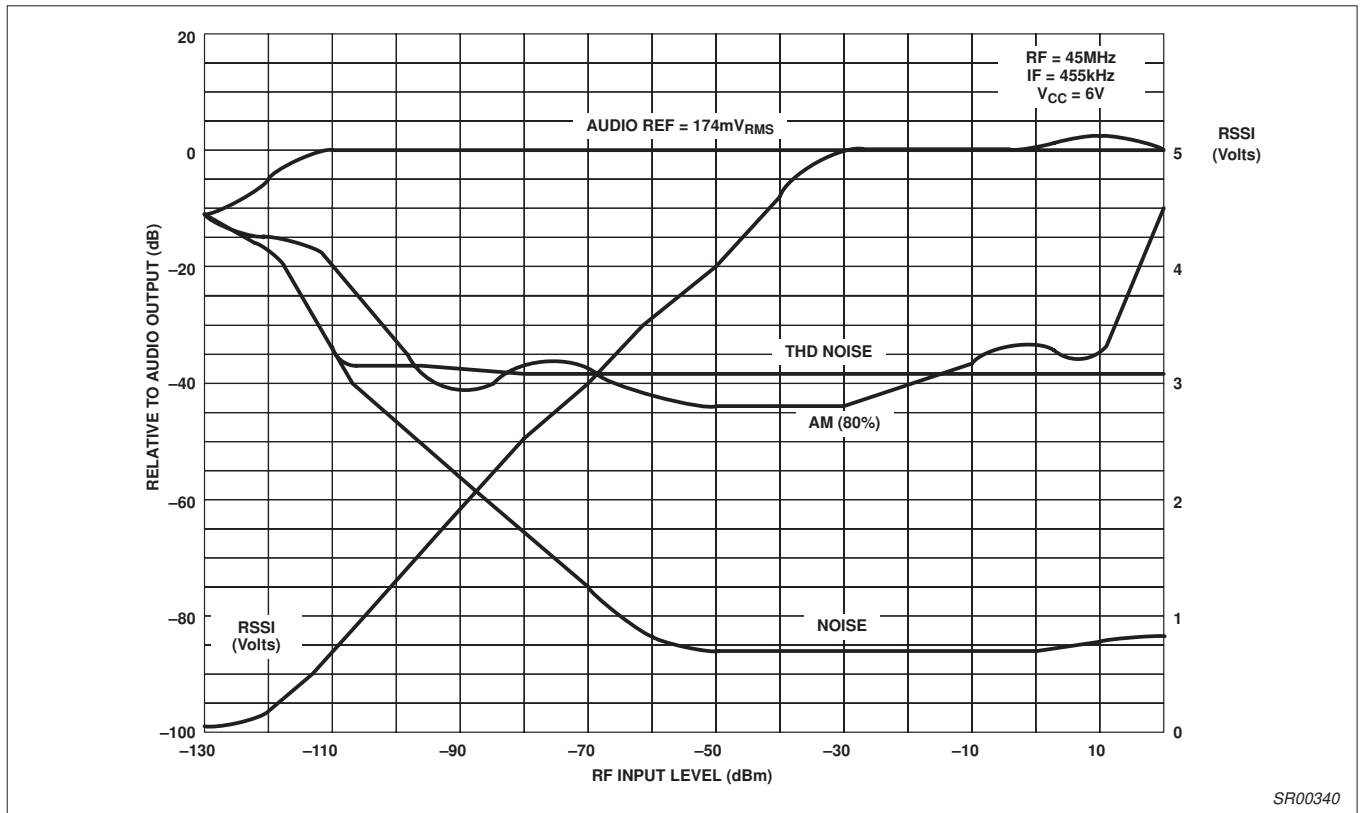

Figure 6. SA605 Application Board at 25°C

SR00340

High performance low power mixer FM IF system

SA605

DIP20: plastic dual in-line package; 20 leads (300 mil)

SOT146-1

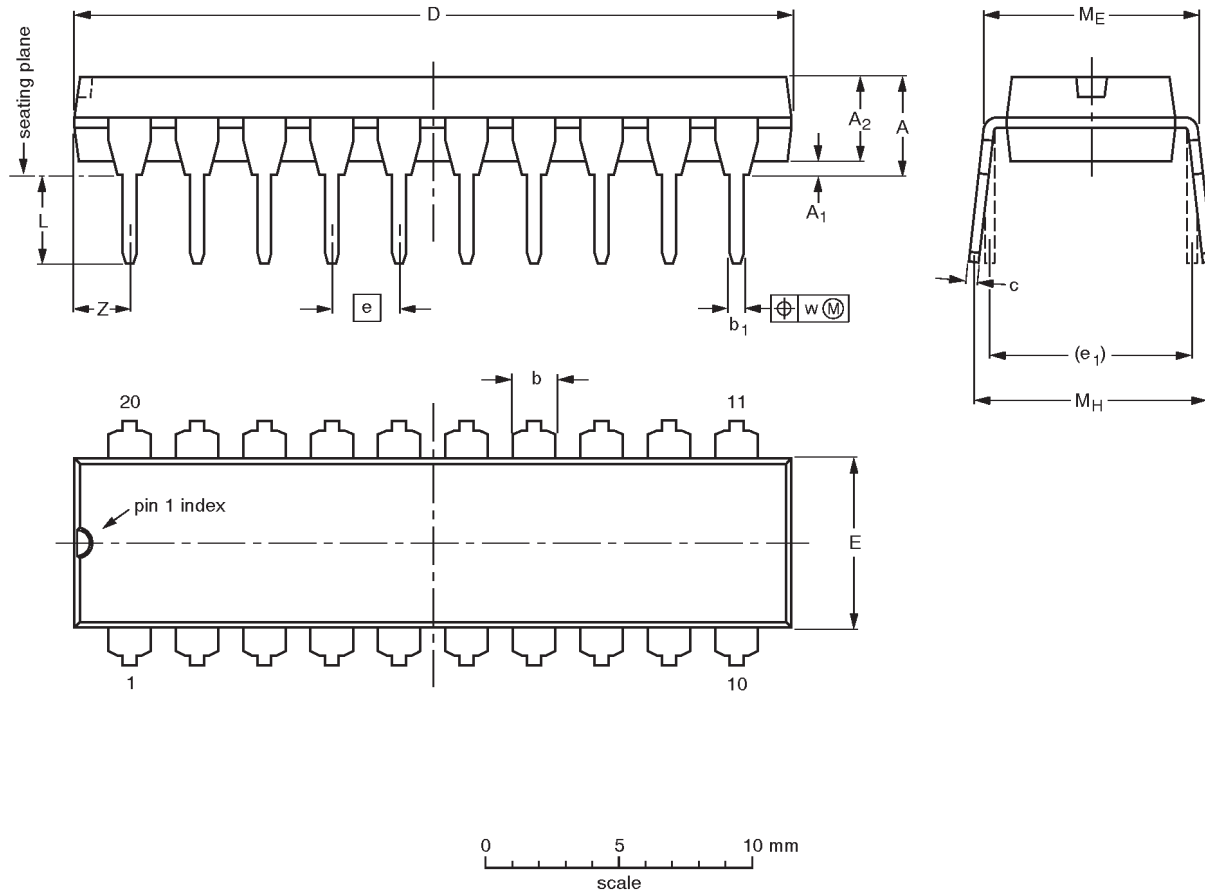

DIMENSIONS (inch dimensions are derived from the original mm dimensions)

UNIT	A max.	A ₁ min.	A ₂ max.	b	b ₁	c	D ⁽¹⁾	E ⁽¹⁾	e	e ₁	L	M _E	M _H	w	Z ⁽¹⁾ max.
mm	4.2	0.51	3.2	1.73 1.30	0.53 0.38	0.36 0.23	26.92 26.54	6.40 6.22	2.54	7.62	3.60 3.05	8.25 7.80	10.0 8.3	0.254	2.0
inches	0.17	0.020	0.13	0.068 0.051	0.021 0.015	0.014 0.009	1.060 1.045	0.25 0.24	0.10	0.30	0.14 0.12	0.32 0.31	0.39 0.33	0.01	0.078

Note

1. Plastic or metal protrusions of 0.25 mm maximum per side are not included.

OUTLINE VERSION	REFERENCES				EUROPEAN PROJECTION	ISSUE DATE
	IEC	JEDEC	EIAJ			
SOT146-1			SC603			92-11-17 95-05-24

High performance low power mixer FM IF system

SA605

SO20: plastic small outline package; 20 leads; body width 7.5 mm

SOT163-1

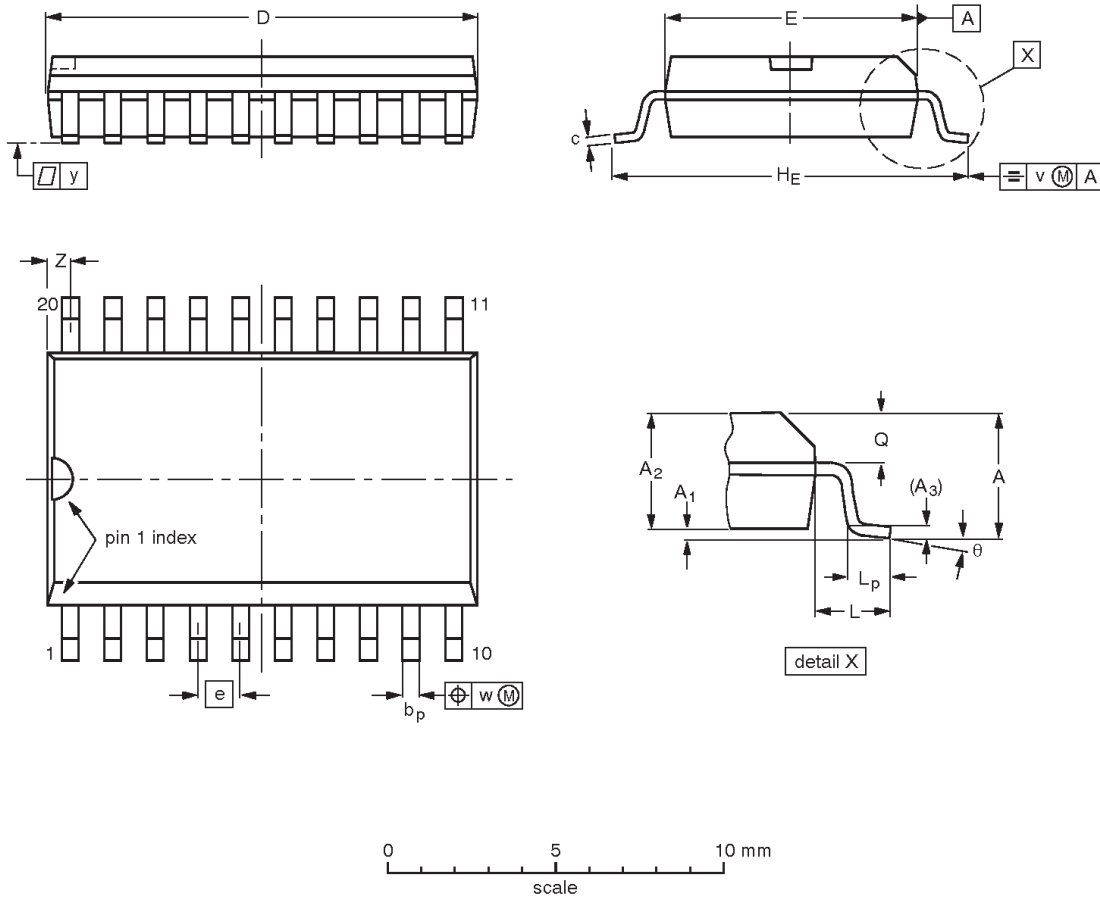

DIMENSIONS (inch dimensions are derived from the original mm dimensions)

UNIT	A max.	A ₁	A ₂	A ₃	b _p	c	D ⁽¹⁾	E ⁽¹⁾	e	H _E	L	L _p	Q	v	w	y	Z ⁽¹⁾	θ
mm	2.65	0.30 0.10	2.45 2.25	0.25	0.49 0.36	0.32 0.23	13.0 12.6	7.6 7.4	1.27	10.65 10.00	1.4	1.1 0.4	1.1 1.0	0.25	0.25	0.1	0.9 0.4	8° 0°
inches	0.10	0.012 0.004	0.096 0.089	0.01	0.019 0.014	0.013 0.009	0.51 0.49	0.30 0.29	0.050	0.42 0.39	0.055	0.043 0.016	0.043 0.039	0.01	0.01	0.004	0.035 0.016	

Note

1. Plastic or metal protrusions of 0.15 mm maximum per side are not included.

OUTLINE VERSION	REFERENCES				EUROPEAN PROJECTION	ISSUE DATE
	IEC	JEDEC	EIAJ			
SOT163-1	075E04	MS-013AC				92-11-17 95-01-24

High performance low power mixer FM IF system

SA605

SSOP20: plastic shrink small outline package; 20 leads; body width 4.4 mm

SOT266-1

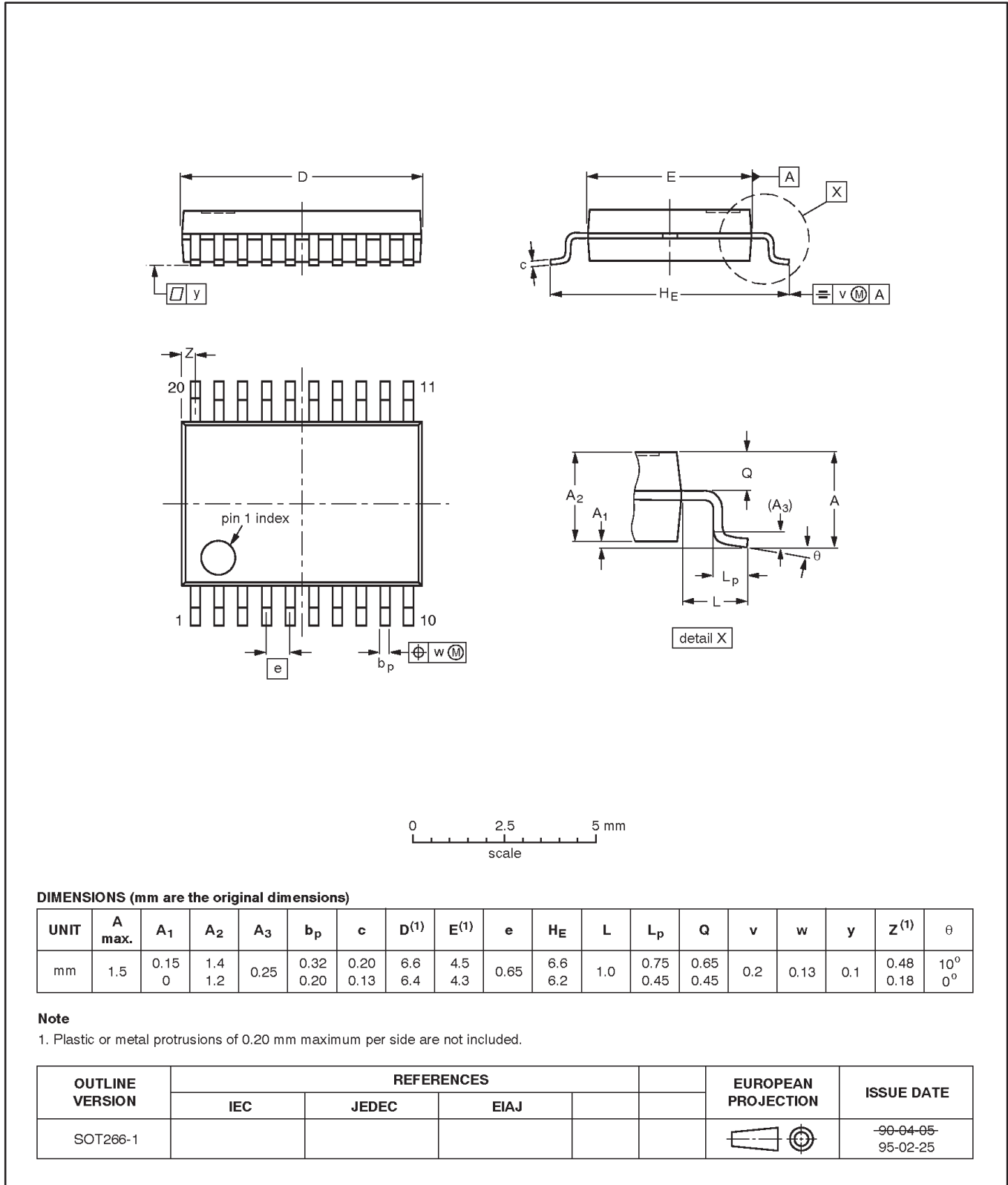

High performance low power mixer FM IF system

SA605

DEFINITIONS

Data Sheet Identification	Product Status	Definition
<i>Objective Specification</i>	Formative or in Design	This data sheet contains the design target or goal specifications for product development. Specifications may change in any manner without notice.
<i>Preliminary Specification</i>	Preproduction Product	This data sheet contains preliminary data, and supplementary data will be published at a later date. Philips Semiconductors reserves the right to make changes at any time without notice in order to improve design and supply the best possible product.
<i>Product Specification</i>	Full Production	This data sheet contains Final Specifications. Philips Semiconductors reserves the right to make changes at any time without notice, in order to improve design and supply the best possible product.

Philips Semiconductors and Philips Electronics North America Corporation reserve the right to make changes, without notice, in the products, including circuits, standard cells, and/or software, described or contained herein in order to improve design and/or performance. Philips Semiconductors assumes no responsibility or liability for the use of any of these products, conveys no license or title under any patent, copyright, or mask work right to these products, and makes no representations or warranties that these products are free from patent, copyright, or mask work right infringement, unless otherwise specified. Applications that are described herein for any of these products are for illustrative purposes only. Philips Semiconductors makes no representation or warranty that such applications will be suitable for the specified use without further testing or modification.

LIFE SUPPORT APPLICATIONS

Philips Semiconductors and Philips Electronics North America Corporation Products are not designed for use in life support appliances, devices, or systems where malfunction of a Philips Semiconductors and Philips Electronics North America Corporation Product can reasonably be expected to result in a personal injury. Philips Semiconductors and Philips Electronics North America Corporation customers using or selling Philips Semiconductors and Philips Electronics North America Corporation Products for use in such applications do so at their own risk and agree to fully indemnify Philips Semiconductors and Philips Electronics North America Corporation for any damages resulting from such improper use or sale.

Philips Semiconductors
811 East Arques Avenue
P.O. Box 3409
Sunnyvale, California 94088-3409
Telephone 800-234-7381

© Copyright Philips Electronics North America Corporation 1997
 All rights reserved. Printed in U.S.A.

Let's make things better.

Philips
Semiconductors



PHILIPS