



Chipsmall Limited consists of a professional team with an average of over 10 year of expertise in the distribution of electronic components. Based in Hongkong, we have already established firm and mutual-benefit business relationships with customers from,Europe,America and south Asia,supplying obsolete and hard-to-find components to meet their specific needs.

With the principle of "Quality Parts,Customers Priority,Honest Operation,and Considerate Service",our business mainly focus on the distribution of electronic components. Line cards we deal with include Microchip,ALPS,ROHM,Xilinx,Pulse,ON,Everlight and Freescale. Main products comprise IC,Modules,Potentiometer,IC Socket,Relay,Connector.Our parts cover such applications as commercial,industrial, and automotives areas.

We are looking forward to setting up business relationship with you and hope to provide you with the best service and solution. Let us make a better world for our industry!



Contact us

Tel: +86-755-8981 8866 Fax: +86-755-8427 6832

Email & Skype: info@chipsmall.com Web: www.chipsmall.com

Address: A1208, Overseas Decoration Building, #122 Zhenhua RD., Futian, Shenzhen, China





Car journeys become much more fun

Nexperia-based automotive audio/video system solutions



Experience home entertainment

Car entertainment for passengers has come a long way since coloring in picture books. Now people are looking for the same popular and convenient media activities they enjoy at home, in the car. Vehicles featuring video-enabled systems on top of more traditional car radios make travel a more pleasurable experience and are fast becoming the “consumer’s choice.”

This is why NXP Semiconductors gives you a simple route to bring multimedia systems to the automotive world. Complete reference solutions, based on our proven best-in-class Nexperia technology, offer you an easy, powerful and versatile way to create audio/video (A/V) applications in the car.



in the car

Movies, music and images

With the NXP Nexperia automotive A/V reference design you can entertain your customers with advanced in-car audio/video solutions. It is the perfect base for creating differentiated, feature-filled products for in-car entertainment with the fastest time-to-market. You can now let passengers appreciate high-quality entertainment from a variety of media – watching video files of their favorite films or playing live or recorded music. And those in the front and rear seats can even choose different entertainment selections at the same time.

Video content can be played from a wide range of sources. As well as the popular DVD format, possible sources also include embedded Flash and HDD storage, USB memory sticks, and SD (Secure Digital) Flash cards. You can also include TV reception in your solutions – all the main standards for in-car TV are covered – together with video playback.

The A/V reference design allows playback of audio from a variety of storage media, and offers comprehensive support of compressed audio files such as MP3, WMA and AAC.

It handles multi-channel audio such as AC3 with ease, enabling higher-end systems that create impressive, surround-sound environments.

Also, simultaneous multiple audio streams allow different combinations of audio delivery including front/rear audio and even audio streaming via Bluetooth - for example from a cell phone for MP3 playback or to headphones.



Complete hardware and software reference design

A complete reference kit includes automotive qualified low-BoM reference board based on the Nexperia media processor PNX9520 along with a comprehensive software offering that covers the following capabilities:

- Automotive qualified components
- Suitable for automotive applications (ambient temp: -40 °C to +85 °C)
- Non-automotive qualified components from NXP
- Non-automotive, non-NXP
- External board

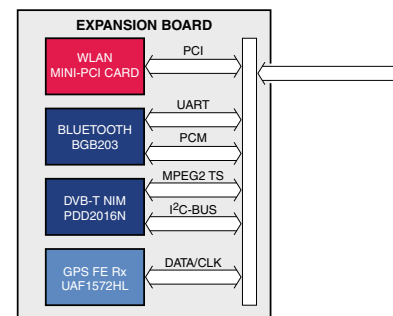
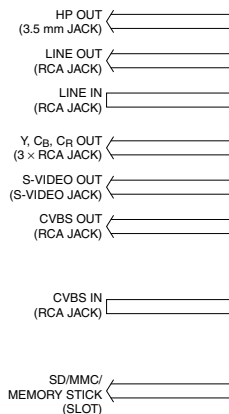

Audio/video playback

- ▶ Playback of all video standards
 - MPEG-1/2/4, DivX-3/4/5, DV, H.263, H.264, etc.
- ▶ Playback of all audio standards
 - Dolby Digital, MP3, WMA, AAC, etc.
 - Compressed audio playback rom HDD/Flash
- ▶ Support for Compact Flash and Secure Digital cards
- ▶ Capable of supporting multiple audio streams simultaneously
- ▶ Support for wireless streaming (Bluetooth, WiFi) to headphones
- ▶ CODEC software is from NXP and royalty free (excluding end-customer licenses)

Audio encoding

- ▶ Supports MP3, WMA, AAC, etc
- ▶ Capable of multi-X ripping from CD/DVD mechanism (up to 8x)

Connectivity/networking

- ▶ TCP/IP for consumer applications
- ▶ CAN for automotive applications
- ▶ MOST network support
- ▶ USB, SD
- ▶ Bluetooth, WiFi

Digital radio

- ▶ Digital Radio Mondiale
- ▶ DAB and others under investigation

Along with leading-edge video post-processing hardware IP, you'll find plenty of power from the system's advanced video hardware, graphics accelerator and audio processing capability. There are also extensive software possibilities, both from NXP and independent vendors in the Nexperia Partnership Program. This wide choice of software also plays a key role in the solution's flexibility, allowing your end-product to include all popular functionality.

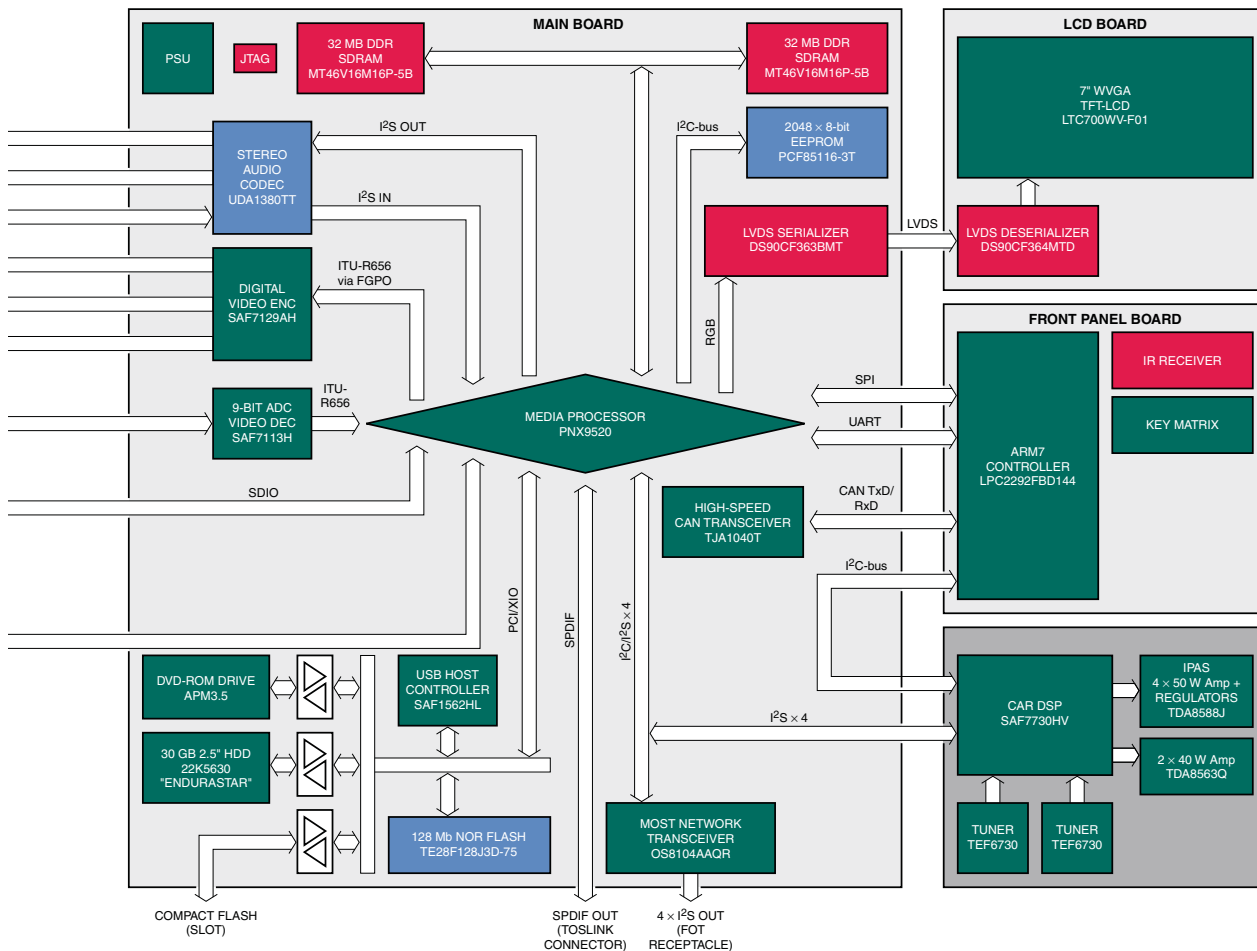

Nexperia: a new standard in automotive

In the consumer electronics domain, Nexperia stands for outstanding multimedia quality. Now we're bringing that expertise to the automotive market.

Nexperia technology gives you best-in-class audio and video performance. It enables easy integration with existing automotive designs through standard interfaces. And it offers the flexibility to support all today's standards with system upgradability to accept emerging or new developments.

For example, our car A/V reference design supports the DVB-T digital broadcasting standard for the very best in-car picture quality.

However it could easily be extended through a software update to support emerging DVB-H services for handheld devices. This flexibility comes from the power of the processing cores combined with the wide range of proven third-party application software available through the Nexperia Partnership Program.

The Nexperia car A/V reference design supports the following standards and formats:







Proven power, proven flexibility...

The Nexperia engine PNX9520

At the heart of our car A/V reference design lies the NXP Nexperia media processor PNX9520. It's a dedicated automotive solution derived from proven Nexperia technology found in mobile/consumer applications – giving it an instant 'stamp of approval' for best-in-class A/V performance.

Popular standard interfaces guarantee easy integration with existing automotive designs, while extensive software options ensure high system flexibility. The Nexperia Partner Program facilitates development of software that complements and augments our own system solutions, helping to support a wide range of opportunities for makers of innovative products.

Key features

Video processing and graphics engine

- ▶ de-interlacing with film mode detector
- ▶ frame rate conversion – PAL to 50 Hz progressive or NTSC to 60 Hz progressive
- ▶ video scaling with presets
- ▶ brightness, color and contrast adjustments
- ▶ dual video stream rendering
- ▶ separate OSD on each of the two video outputs
- ▶ advanced graphics capabilities such as alpha bending and anti-aliases scaling

Video decoding

- ▶ MPEG-1, MPEG-2 and MPEG-4 video
- ▶ DivX video
- ▶ Windows Media Video
- ▶ JPEG picture display

Audio decoding

- ▶ MPEG-1 layer 2 and 3, MPEG-2 layer 2 and MPEG-4 AAC
- ▶ AC3 (Dolby Digital)
- ▶ PCM
- ▶ Windows Media Audio
- ▶ Oggvorbis

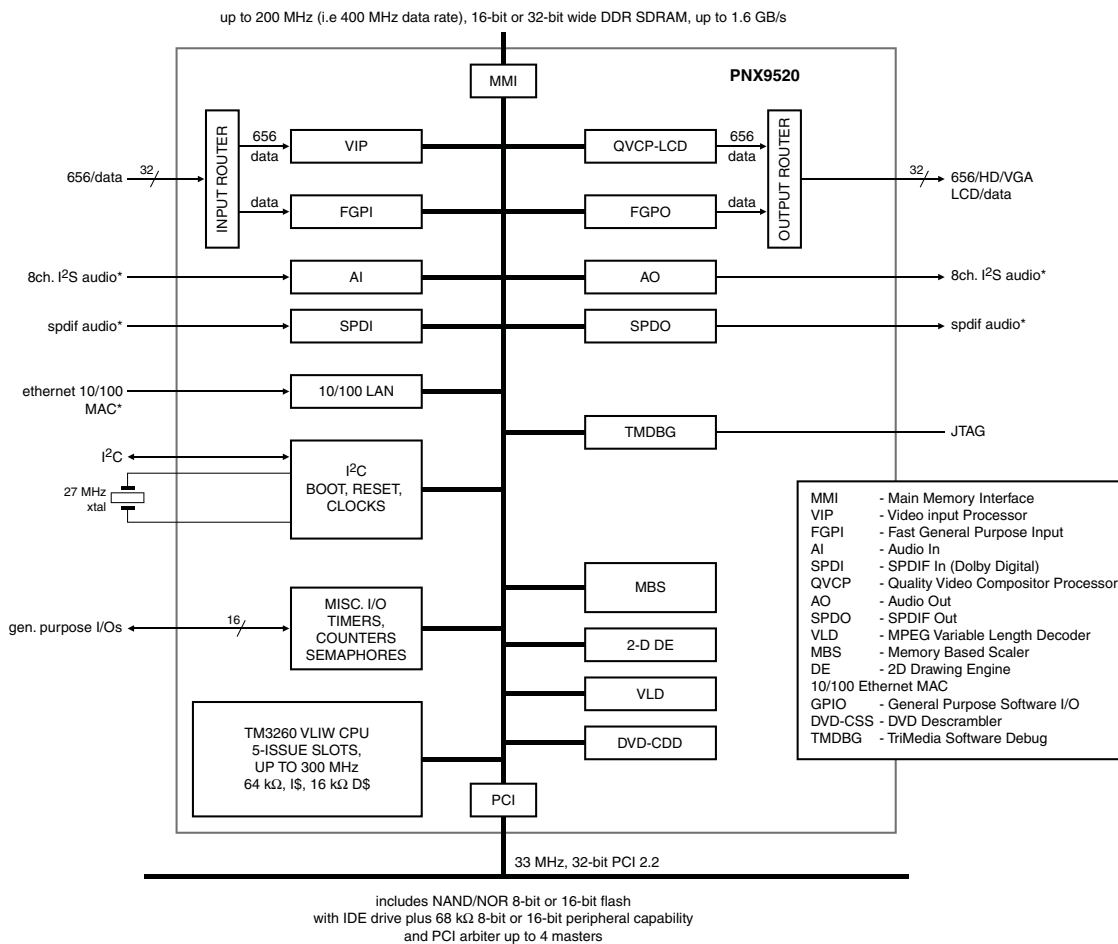

...and proven capabilities

Through the Nexperia Partner Program, third-party companies developing middleware, applications or software CODECs and those offering system design or integration services can collaborate with NXP on new Nexperia applications and devices. This ensures you have access to a complete suite of proven software across a wide range of potential applications.

Available separately from NXP, the Nexperia Development Kit (NDK) gives developers a full suite of system software tools to develop applications for the PNX9520's TriMedia CPU. It includes a compiler, debugger, audio/video drivers and example software. This comprehensive software development environment dramatically lowers cost and reduces time-to-market by enabling development of multimedia applications entirely in the C and C++ programming languages. Application libraries for the PNX9520 are available from NXP and third parties.



Application Software

Media Processing Tool Kit

MPEG1/2

DivX

WMV9

AC3

JPEG

MPEG4

H264

H261/3

AAC

MP3

Nexperia Development Kit

OS

Network

Video/
Audio
I/O drivers

Compilers

Linkers

Debuggers

Complete solutions

Codec libraries (royalty free)

Basic development tools



www.nxp.com

NXP Semiconductors is in the process of being established as a separate legal entity in various countries worldwide. This process will be finalized in the course of 2006.

© 2006 Koninklijke Philips Electronics N.V.

All rights reserved. Reproduction in whole or in part is prohibited without the prior written consent of the copyright owner. The information presented in this document does not form part of any quotation or contract, is believed to be accurate and reliable and may be changed without notice. No liability will be accepted by the publisher for any consequence of its use. Publication thereof does not convey nor imply any license under patent- or other industrial or intellectual property rights.

Date of release: September 2006
Document order number: 9397 750 15651
Printed in the Netherlands

founded by

PHILIPS