



Chipsmall Limited consists of a professional team with an average of over 10 year of expertise in the distribution of electronic components. Based in Hongkong, we have already established firm and mutual-benefit business relationships with customers from,Europe,America and south Asia,supplying obsolete and hard-to-find components to meet their specific needs.

With the principle of "Quality Parts,Customers Priority,Honest Operation,and Considerate Service",our business mainly focus on the distribution of electronic components. Line cards we deal with include Microchip,ALPS,ROHM,Xilinx,Pulse,ON,Everlight and Freescale. Main products comprise IC,Modules,Potentiometer,IC Socket,Relay,Connector.Our parts cover such applications as commercial,industrial, and automotives areas.

We are looking forward to setting up business relationship with you and hope to provide you with the best service and solution. Let us make a better world for our industry!



Contact us

Tel: +86-755-8981 8866 Fax: +86-755-8427 6832

Email & Skype: info@chipsmall.com Web: www.chipsmall.com

Address: A1208, Overseas Decoration Building, #122 Zhenhua RD., Futian, Shenzhen, China



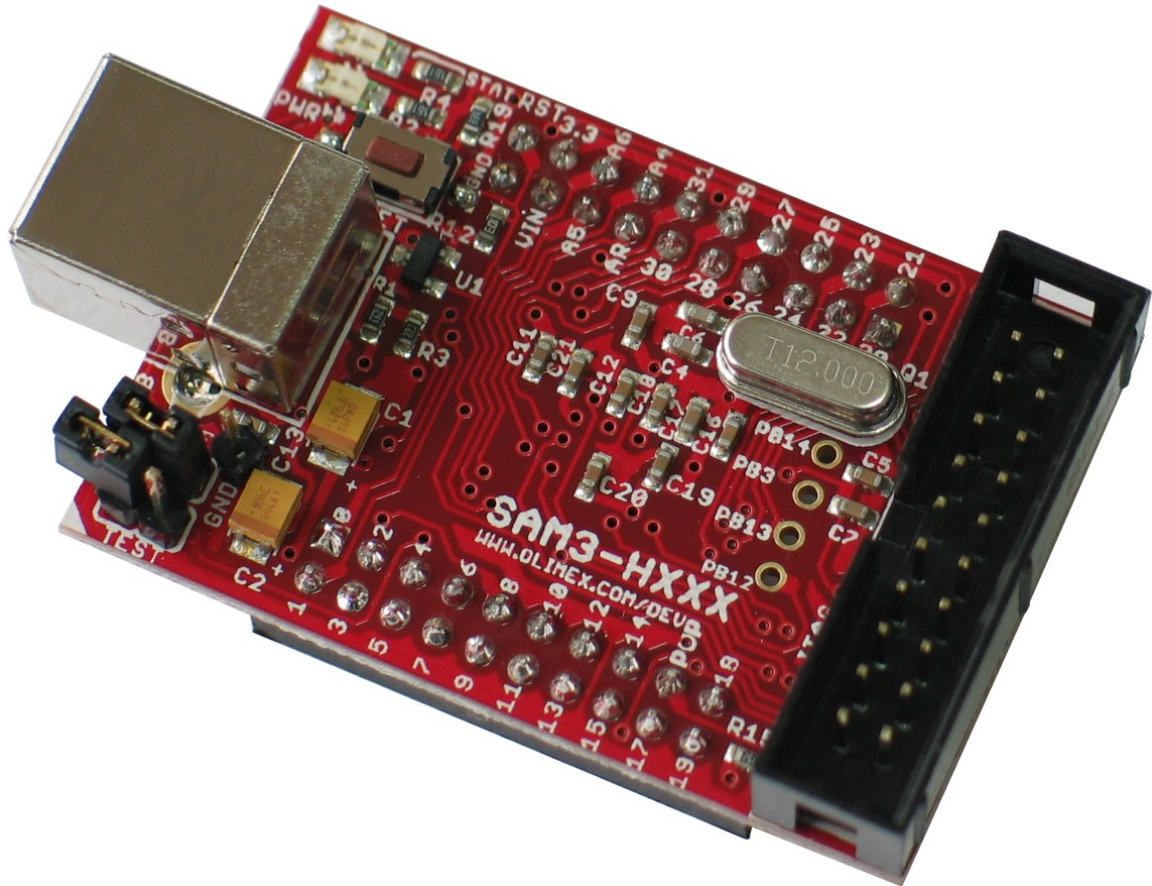

SAM3-H256 development board

Users Manual



All boards produced by Olimex are ROHS compliant

Rev. Initial, April 2011

Copyright(c) 2011, OLIMEX Ltd, All rights reserved

INTRODUCTION:

Atmel's **ATSAM3S4BA-AU** is a member of a series of Flash microcontrollers based on the high performance 32-bit ARM Cortex-M3 RISC processor. It operates at a maximum speed of 64 MHz and features a 256 Kbyte Flash and a 48 Kbyte SRAM, Full Speed USB Device port with embedded transceiver, an External Bus Interface featuring a Static Memory Controller providing connection to SRAM, PSRAM, NOR Flash and NAND Flash, 2x USARTs, 2x UARTs, 2x TWIs, 3x SPI, an I2S, as well as 1 PWM timer, 6x general-purpose 16-bit timers, an RTC, an ADC, a 12-bit DAC and an analog comparator.

SAM3-H256 has connectors for JTAG and USB, extension headers for all microcontroller's ports, reset button, power and status leds.

BOARD FEATURES:

- Microcontroller: **ATSAM3S4BA-AU**.
- standard JTAG connector with ARM 2x10 pin layout for programming/debugging with ARM-JTAG
- status LED
- on board voltage regulator 3.3V with up to 800mA current
- power supply LED
- power supply filtering capacitor
- RESET circuit
- RESET button
- 12.000 Mhz crystal on socket
- extension headers for all microcontroller's ports
- PCB: FR-4, 1.5 mm (0,062"), soldermask, silkscreen component print
- Dimensions: 50.00 x 33.75 mm (1.97 x 1.33")

ELECTROSTATIC WARNING:

The **SAM3-H256** board is shipped in protective anti-static packaging. The board must not be subject to high electrostatic potentials. General practice for working with static sensitive devices should be applied when working with this board.

BOARD USE REQUIREMENTS:

Cables: The cable you will need depends on the programmer/debugger you use. If you use [ARM-JTAG-EW](#), you will need USB A-B cable.

Hardware: Programmer/Debugger [ARM-JTAG-EW](#) or other compatible programming/debugging tool if you work with EW-ARM.

You can use also [ARM-USB-OCD](#), [ARM-USB-TINY](#), [ARM-USB-OCD-H](#), [ARM-USB-TINY-H](#).

PROCESSOR FEATURES:

SAM3-H256 board use ARM-based microcontroller **ATSAM3S4BA-AU** from Atmel Corporation with these features:

- Core
 - ARM® Cortex®-M3 revision 2.0 running at 64 MHz
 - Memory Protection Unit (MPU)
 - Thumb®-2 instruction set
- Pin-to-pin compatible with AT91SAM7S legacy products (48- and 64-pin versions)
- Memories
 - 256 Kbytes embedded Flash, 128-bit wide access, memory accelerator, single plane
 - 48 Kbytes embedded SRAM
 - 16 Kbytes ROM with embedded bootloader routines (UART, USB) and IAP routines
 - 8-bit Static Memory Controller (SMC): SRAM, PSRAM, NOR and NAND Flash support
 - Memory Protection Unit (MPU)
- System
 - Embedded voltage regulator for single supply operation
 - Power-on-Reset (POR), Brown-out Detector (BOD) and Watchdog for safe operation
 - Quartz or ceramic resonator oscillators: 3 to 20 MHz main power with Failure Detection and optional low power 32.768 kHz for RTC or device clock
 - High precision 8/12 MHz factory trimmed internal RC oscillator with 4 MHz default frequency for device startup. In-application trimming access for frequency adjustment
 - Slow Clock Internal RC oscillator as permanent low-power mode device clock
 - Two PLLs up to 130 MHz for device clock and for USB
 - Temperature Sensor
 - Up to 22 peripheral DMA (PDC) channels
- Low Power Modes
 - Sleep and Backup modes, down to 3 µA in Backup mode

- Ultra low power RTC
- Peripherals
 - USB 2.0 Device: 12 Mbps, 2668 byte FIFO, up to 8 bidirectional Endpoints. On-Chip Transceiver
 - 2 USARTs with ISO7816, IrDA®, RS-485, SPI, Manchester and Modem Mode
 - Two 2-wire UARTs
 - 2 Two Wire Interface (I2C compatible), 1 SPI, 1 Serial Synchronous Controller (I2S), 1 High Speed Multimedia Card Interface (SDIO/SD Card/MMC)
 - 3 Three-Channel 16-bit Timer/Counter with capture, waveform, compare and PWM mode. Quadrature Decoder Logic and 2-bit Gray Up/Down Counter for Stepper Motor
 - 4-channel 16-bit PWM with Complementary Output, Fault Input, 12-bit Dead Time Generator Counter for Motor Control
 - 32-bit Real-time Timer and RTC with calendar and alarm features
 - 10-channel ADC with differential input mode and programmable gain stage
 - Two 12-bit DAC outputs
 - One Analog Comparator with flexible input selection, Selectable input hysteresis
 - 32-bit Cyclic Redundancy Check Calculation Unit (CRCCU)
- I/O
 - 47 I/O lines with external interrupt capability (edge or level sensitivity), debouncing, glitch filtering and on-die Series Resistor Termination
 - Three 32-bit Parallel Input/Output Controllers, Peripheral DMA assisted Parallel Capture Mode

BLOCK DIAGRAM:

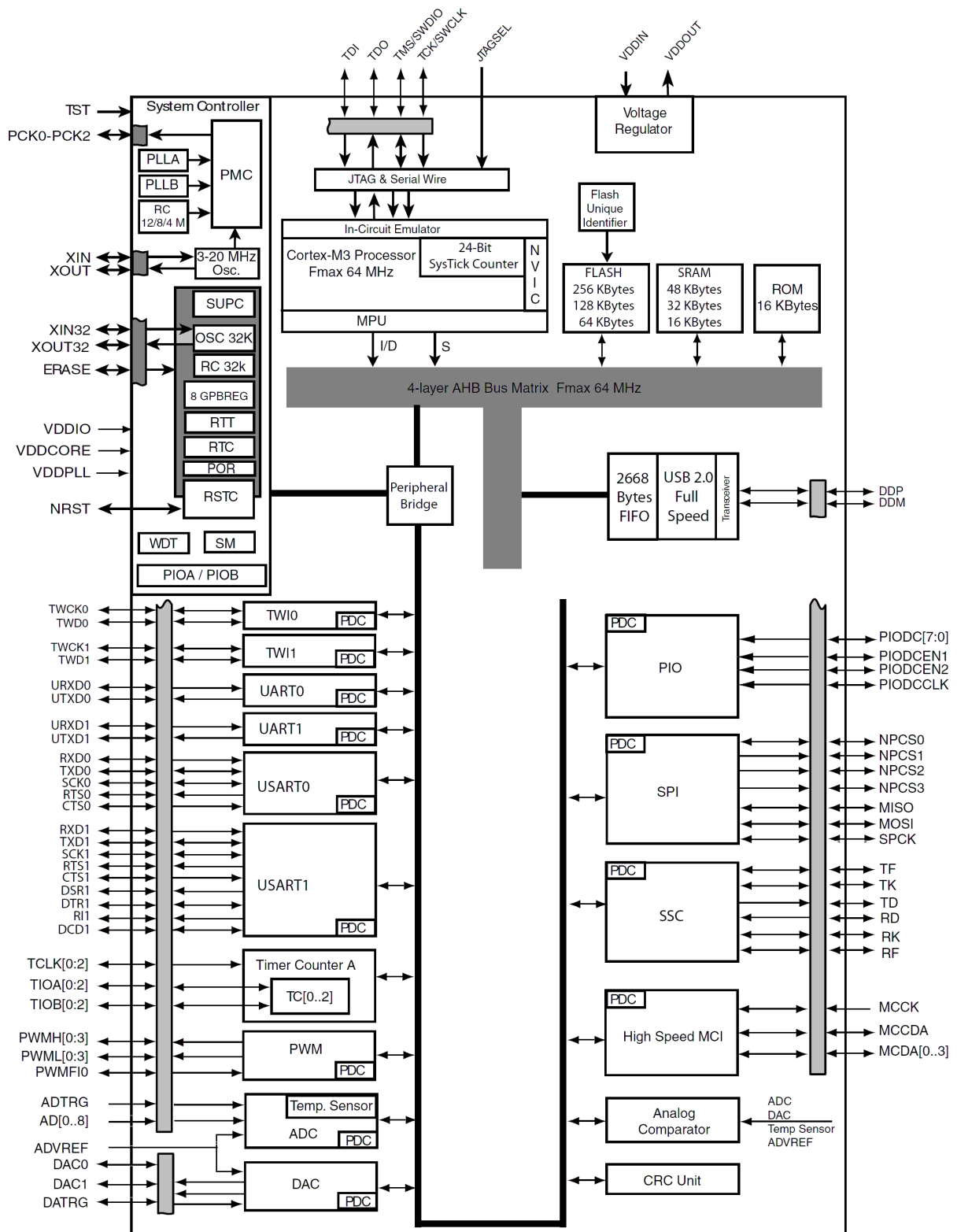

MEMORY MAP:

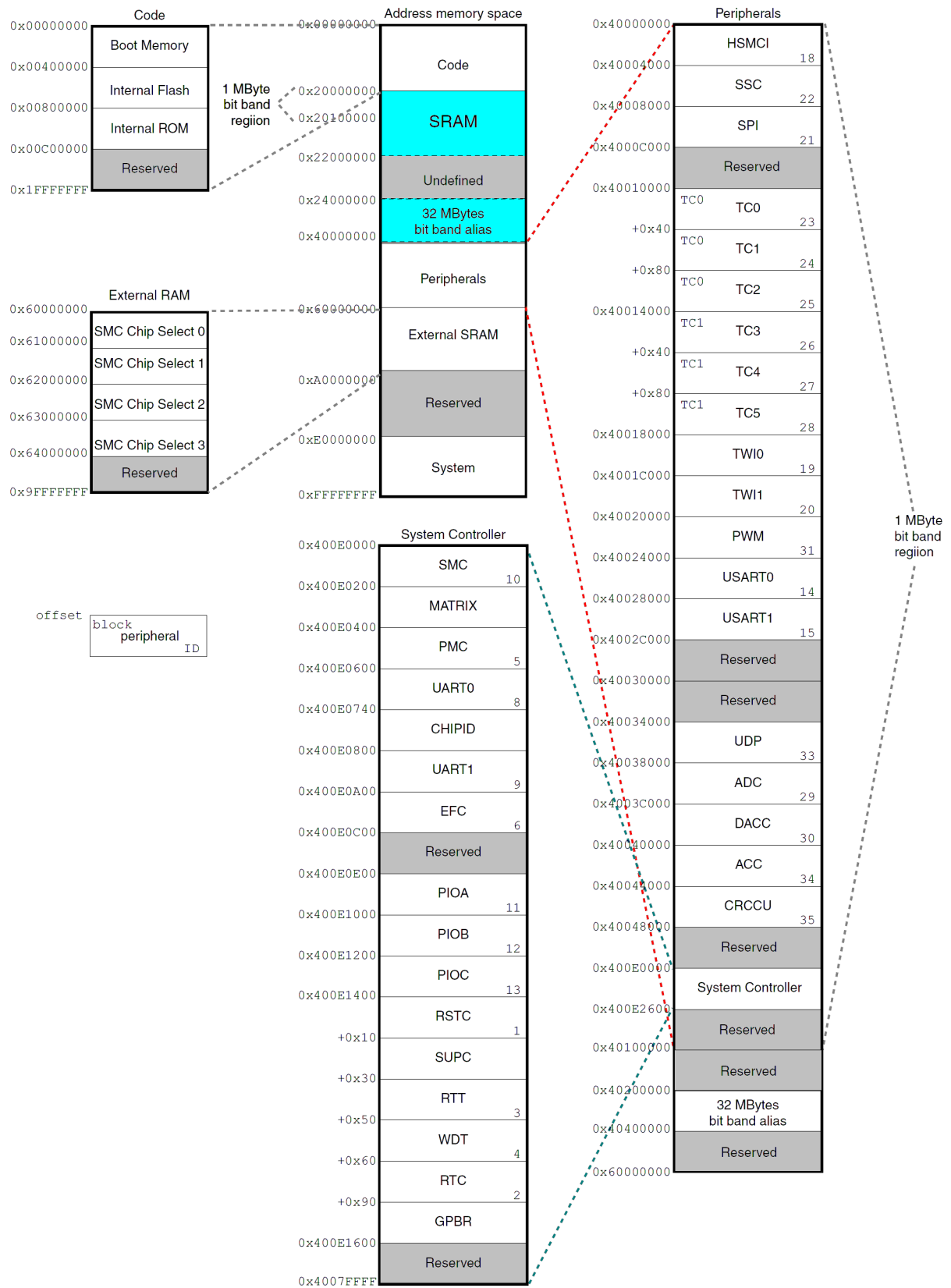

SAM3-H256

Rev. Initial
COPYRIGHT(C) 2011, OLIMEX LTD.
<http://www.olimex.com/dev>

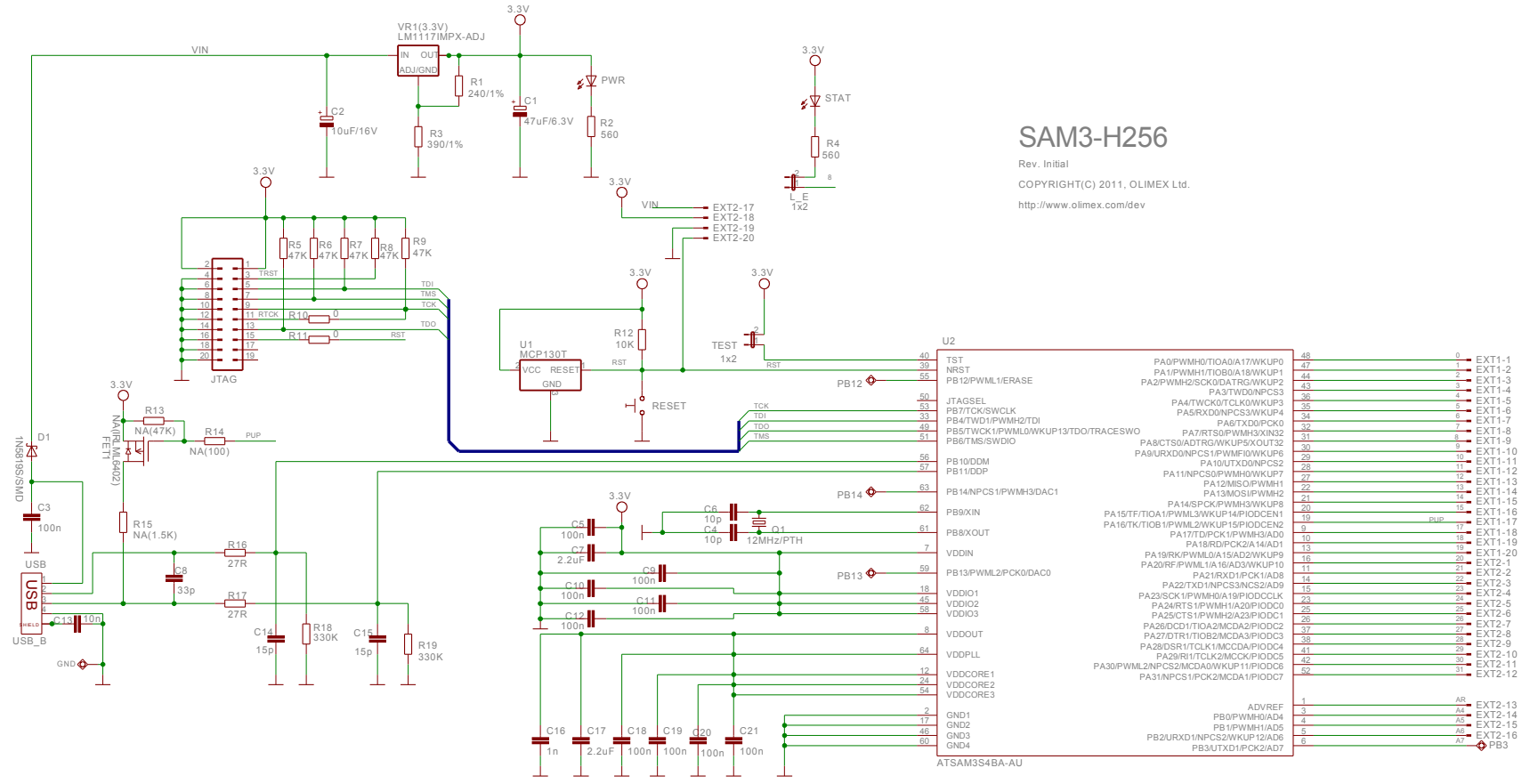

BOARD LAYOUT:

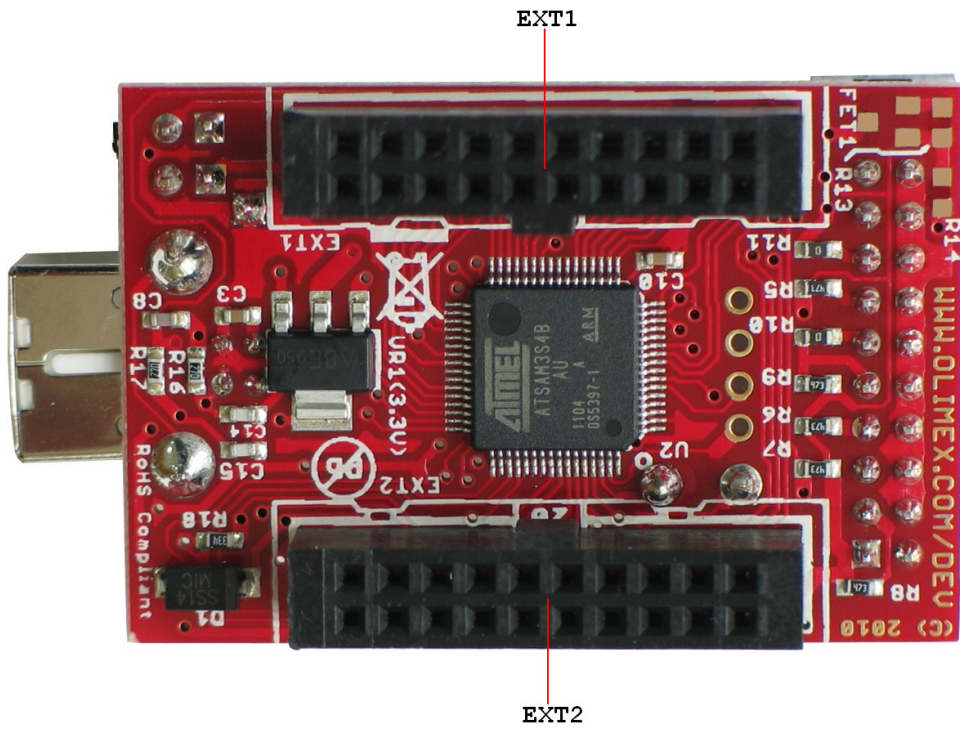
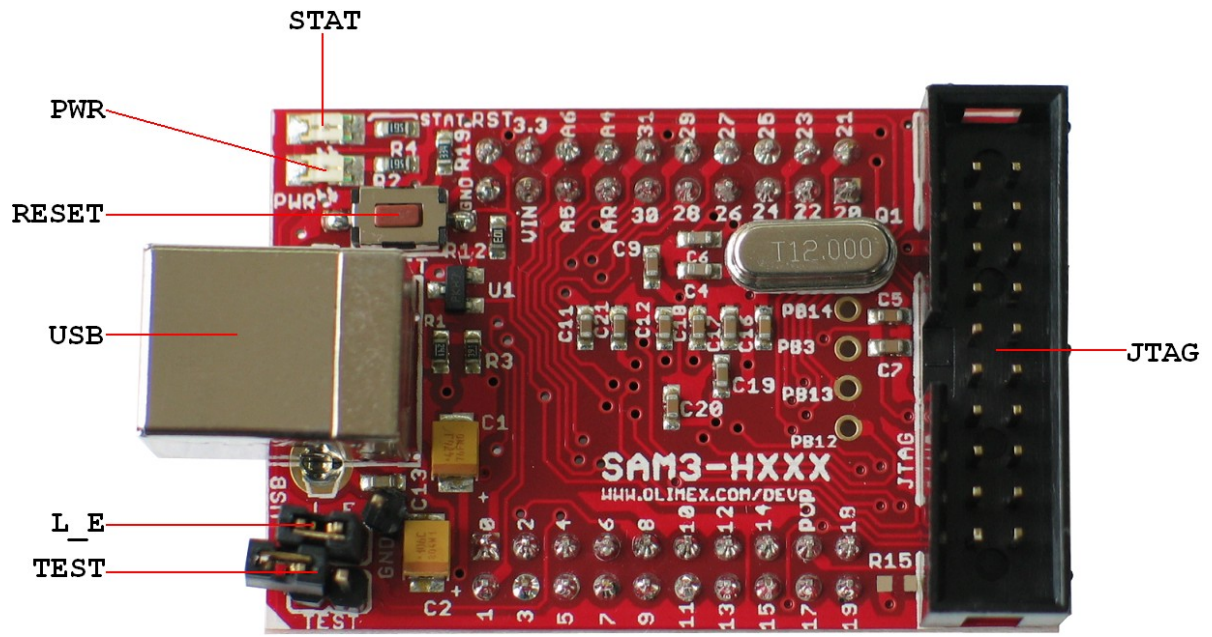

POWER SUPPLY CIRCUIT:

SAM3-H256 is typically power supplied with +5 V from USB, but it also can be power supplied with +5VDC via extension connector (signal VIN from EXT2 connector pin17).

The programmed board power consumption is about 50 mA.

RESET CIRCUIT:

SAM3-H256 reset circuit includes U1 (MCP130T), R12 (10k), JTAG connector pin 15, EXT2 pin 20, ATSAM3S4BA-AU pin 39 (NRST) and RESET button.

CLOCK CIRCUIT:

Quartz crystal **Q1** 12.000 MHz is connected to ATSAM3S4BA-AU pin 61 (PB8/XOUT) and pin 62 (PB9/XIN).

JUMPER DESCRIPTION:

L_E



This jumper, when closed, enables status led - STAT.
Default state is closed.

TEST



This jumper, when closed, connects ATSAM3S4BA-AU pin 40 (TST) to 3.3V. The TST pin is used for JTAG Boundary Scan Manufacturing Test or Fast Flash programming mode.
When TEST jumper is opened - normal mode is enabled.
Default state is opened.

Description for programming via USB port using SAM-BA software

The ATSAM3S4BA-AU can be programmed via USB using the SAM-BA™ software. Before being able to use SAM-BA, a recovery procedure, which consists of copying the SAM-BA Boot Assistant into Flash must be performed as follows:

1. Disconnect board from USB
2. Connect PB12 to 3.3V
3. Power up the board
4. Wait 10s
5. Power down the board
6. Remove the connection between PB12 and 3.3V
7. Power up the board via USB
8. If SAM-BA USB driver are installed you can use SAM-BA tool

INPUT/OUTPUT:

Status Led (green) with name **STAT** connected via jumper **L_E** to **ATSAM3S4BA-AU** pin 31 (PA8/CTS0/ADTRG/WKUP5/XOUT32).

Power-on LED (red) with name **PWR** - this LED shows that +3.3V is applied to the board.

Reset button with name **RESET** connected to **ATSAM3S4BA-AU** pin 39 (NRST).

EXTERNAL CONNECTORS DESCRIPTION:

JTAG:

The JTAG connector allows the software debugger to talk via a JTAG (Joint Test Action Group) port directly to the core. Instructions may be inserted and executed by the core thus allowing ATSAM3S4BA-AU memory to be programmed with code and executed step by step by the host software.

For more details refer to IEEE Standard 1149.1 - 1990 Standard Test Access Port and Boundary Scan Architecture and ATSAM3S4BA-AU datasheets and users manual.

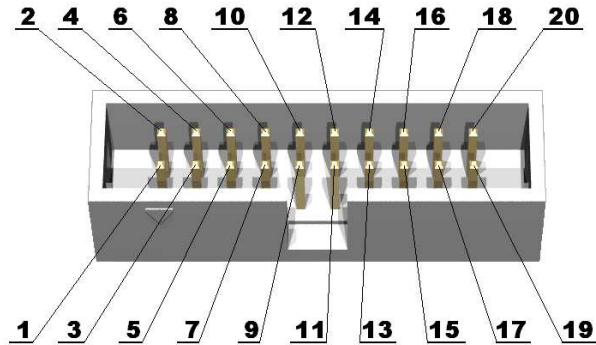

Pin #	Signal Name	Pin #	Signal Name
1	3.3V	2	3.3V
3	TRST	4	GND
5	TDI	6	GND
7	TMS	8	GND
9	TCK	10	GND
11	RTCK	12	GND
13	TDO	14	GND
15	RST	16	GND
17	NC	18	GND
19	NC	20	GND

USB:

Pin #	Signal Name
1	VIN
2	DDM
3	DDP
4	GND

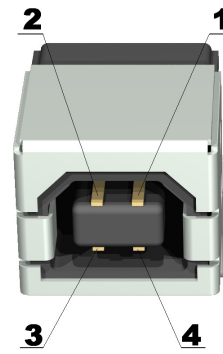

EXT1:

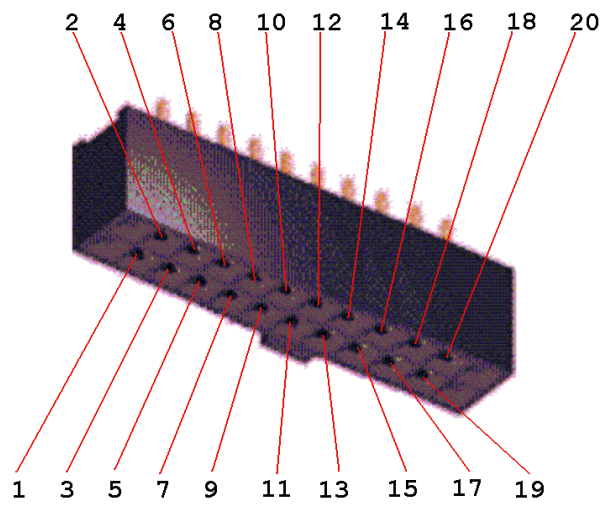

Pin #	Signal Name	Pin #	Signal Name
1	0 - (PA0)	2	1 - (PA1)
3	2 - (PA2)	4	3 - (PA3)
5	4 - (PA4)	6	5 - (PA5)
7	6 - (PA6)	8	7 - (PA7)
9	8 - (PA8)	10	9 - (PA9)
11	10 - (PA10)	12	11 - (PA11)
13	12 - (PA12)	14	13 - (PA13)
15	14 - (PA14)	16	15 - (PA15)
17	PUP - (PA16)	18	17 - (PA17)
19	18 - (PA18)	20	19 - (PA19)

EXT2:

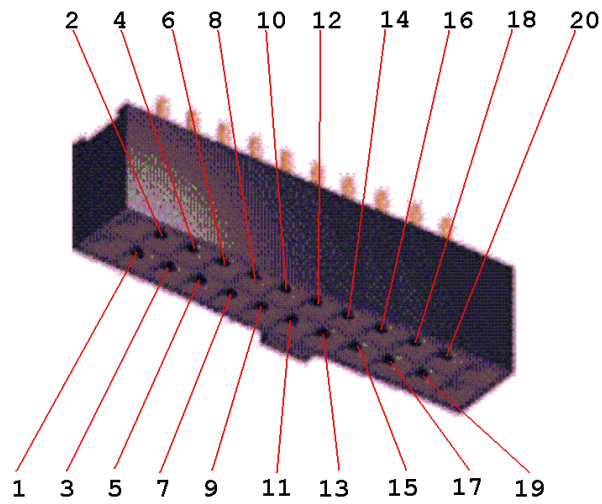

Pin #	Signal Name	Pin #	Signal Name
1	20 - (PA20)	2	21 - (PA21)
3	22 - (PA22)	4	23 - (PA23)
5	24 - (PA24)	6	25 - (PA25)
7	26 - (PA26)	8	27 - (PA27)
9	28 - (PA28)	10	29 - (PA29)
11	30 - (PA30)	12	31 - (PA31)
13	AR - (ADVREF)	14	A4 - (PB0)
15	A5 - (PB1)	16	A6 - (PB2)
17	VIN	18	VCC
19	GND	20	RST

MECHANICAL DIMENSIONS:

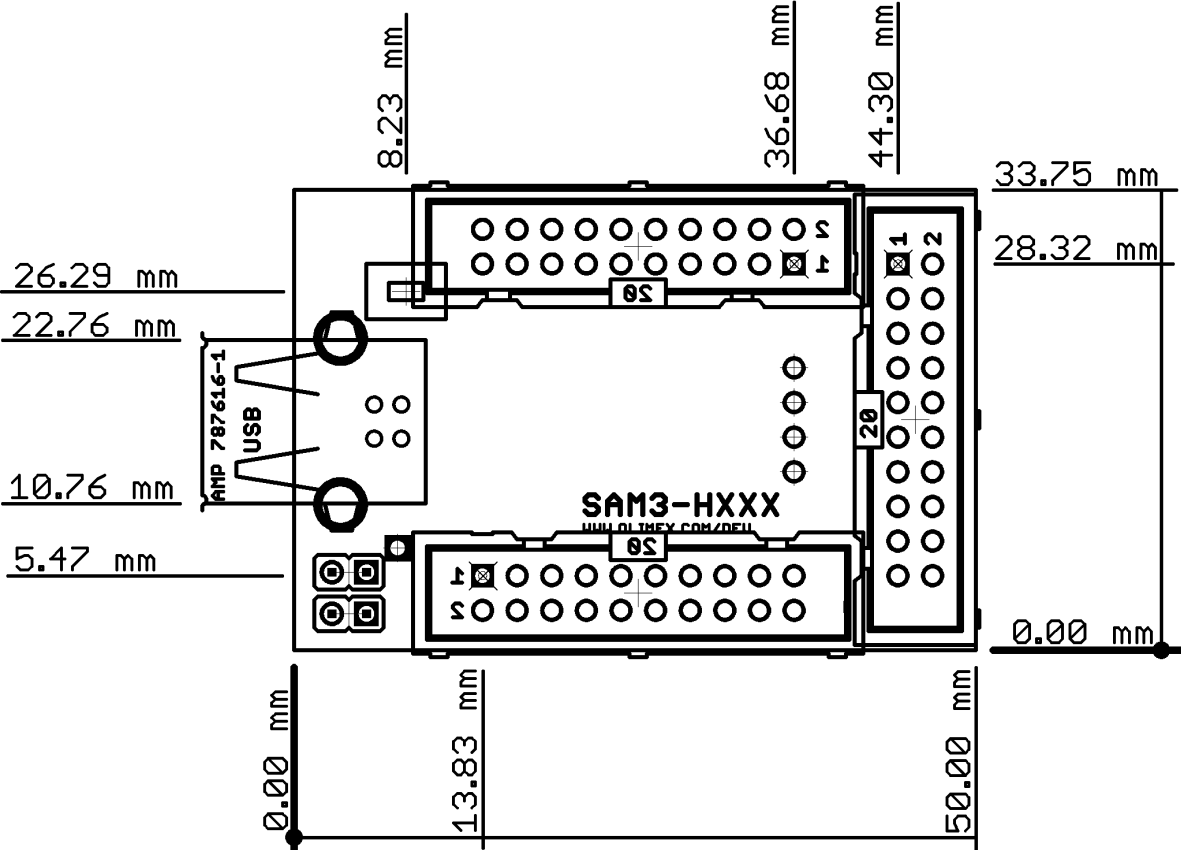

AVAILABLE DEMO SOFTWARE:

Demonstrates USB mouse and a blinking led.

You can find it at <http://www.olimex.com/dev> at the board's specific page.

ORDER CODE:

SAM3-H256 - assembled and tested board

How to order?

You can order to us directly or by any of our distributors.
Check our web www.olimex.com/dev for more info.

Revision history:

Board's Revision:	Initial, October 2010
Manual's Revision	Initial, April 2011

Disclaimer:

© 2011 Olimex Ltd. All rights reserved. Olimex®, logo and combinations thereof, are registered trademarks of Olimex Ltd. Other terms and product names may be trademarks of others.

The information in this document is provided in connection with Olimex products. No license, express or implied or otherwise, to any intellectual property right is granted by this document or in connection with the sale of Olimex products.

Neither the whole nor any part of the information contained in or the product described in this document may be adapted or reproduced in any material from except with the prior written permission of the copyright holder.

The product described in this document is subject to continuous development and improvements. All particulars of the product and its use contained in this document are given by OLIMEX in good faith. However all warranties implied or expressed including but not limited to implied warranties of merchantability or fitness for purpose are excluded.

This document is intended only to assist the reader in the use of the product. OLIMEX Ltd. shall not be liable for any loss or damage arising from the use of any information in this document or any error or omission in such information or any incorrect use of the product.