



Chipsmall Limited consists of a professional team with an average of over 10 year of expertise in the distribution of electronic components. Based in Hongkong, we have already established firm and mutual-benefit business relationships with customers from,Europe,America and south Asia,supplying obsolete and hard-to-find components to meet their specific needs.

With the principle of “Quality Parts,Customers Priority,Honest Operation,and Considerate Service”,our business mainly focus on the distribution of electronic components. Line cards we deal with include Microchip,ALPS,ROHM,Xilinx,Pulse,ON,Everlight and Freescale. Main products comprise IC,Modules,Potentiometer,IC Socket,Relay,Connector.Our parts cover such applications as commercial,industrial, and automotives areas.

We are looking forward to setting up business relationship with you and hope to provide you with the best service and solution. Let us make a better world for our industry!



Contact us

Tel: +86-755-8981 8866 Fax: +86-755-8427 6832

Email & Skype: info@chipsmall.com Web: www.chipsmall.com

Address: A1208, Overseas Decoration Building, #122 Zhenhua RD., Futian, Shenzhen, China



Trapped Single Key Bolt Interlocks

The single key bolt interlock is used to lock on or off host electrical equipment such as large isolators or grounding units and as an interlock on sliding gates or hatches where part body access only is required.

- Direct drive push/pull operation
- 316 Stainless steel construction
- Fitted with tamper resistant screws
- Virtually maintenance free
- Weatherproof stainless steel dust cap as standard
- Screws may be applied from the rear for increased tamper resistance
- Conforms to EN292, EN1088 & GS ET 19



Specifications

Ambient Temperature:	-40 to 200°C (-40 to 392°F)
Mechanical Operations:	>10 ⁶
Max. Shear Force to Key:	15.1 kN
Max. Torque to Key:	14 Nm
Relative Operating Humidity:	25% to 95%
Weight:	SBL: (0.60 kg) 1.32 lb.)
Material:	316L stainless steel
Mounting:	SBL: 2 x 3/8 in. SBL: 2 x 3/8 in.
Code Barrels:	Tested to 1,000,000 operations
Bolt:	15 mmØ
Conforms to Standards:	Relevant clauses EN292, EN1088 & GS ET 19

Specifications are subject to change without notice.

M

Applications

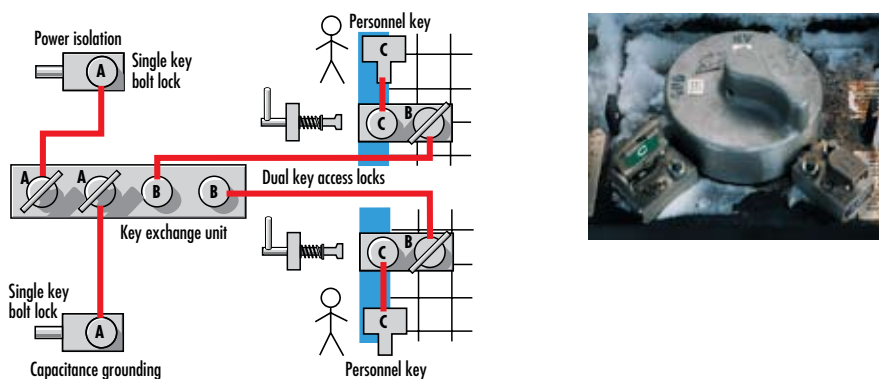

Dimensions

(mm/in.)

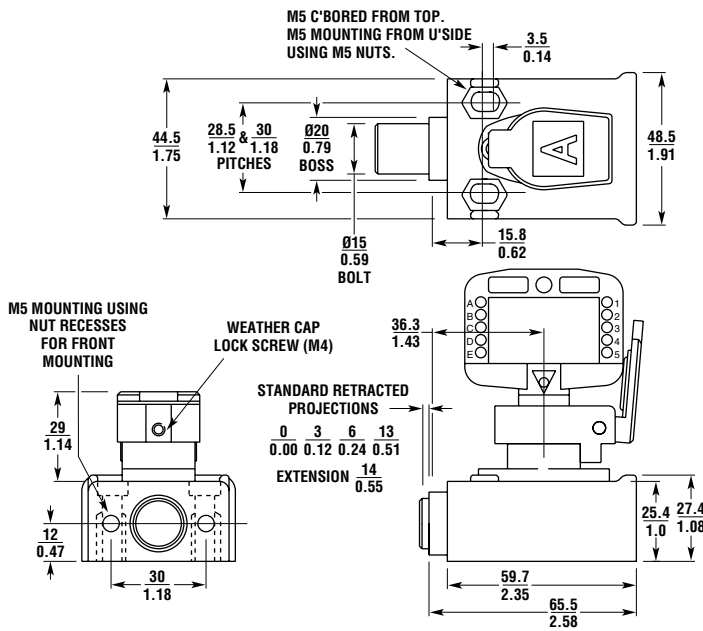

Ordering

Single Key Bolt Interlock

Type/Bolt Part No.	Projection	
	(Retracted)	(Extended)
SBL 10	0 mm (0 in.)	14 mm (0.55 in.)
SBL 11	3 mm (0.12 in.)	17 mm (0.67 in.)
SBL 12	6 mm (0.24 in.)	20 mm (0.79 in.)
SBL 13	13 mm (0.51 in.)	27 mm (1.06 in.)

Codes 'A' to 'Z' available excluding the letter 'Q'. To specify coding, add the key code of your choice from the Key Code Table to the part no. from the Ordering Table, i.e. SBL11(A) is a single key bolt interlock with primary 'A' key. **Key ordered separately.**

Key Codes

(....) = Primary key / key free
 [...] = Secondary key / key trapped

Codes						
A	Aa	Ab	Ac	Ad	Ae	Af
B	Ba	Bb	Bc	Bd	Be	Bf
C	Ca	Cb	Cc	Cd	Ce	Cf
D	Da	Db	Dc	Dd	De	Df
E	Ea	Eb	Ec	Ed	Ee	Ef
F	Fa	Fb	Fc	Fd	Fe	Ff
G	Ga	Gb	Gc	Gd	Ge	Gf
H	Ha	Hb	Hc	Hd	He	Hf
I	Ia	Ib	Ic	Id	Ie	If
J	Ja	Jb	Jc	Jd	Je	Jf
K	Ka	Kb	Kc	Kd	Ke	Kf
L	La	Lb	Lc	Ld	Le	Lf
M	Ma	Mb	Mc	Md	Me	Mf
N	Na	Nb	Nc	Nd	Ne	Nf
O	Oa	Ob	Oc	Od	Oe	Of
P	Pa	Pb	Pc	Pd	Pe	Pf
R	Ra	Rb	Rc	Rd	Re	Rf
S	Sa	Sb	Sc	Sd	Se	Sf
T	Ta	Tb	Tc	Td	Te	Tf
U	Ua	Ub	Uc	Ud	Ue	Uf
V	Va	Vb	Vc	Vd	Ve	Vf
W	Wa	Wb	Wc	Wd	We	Wf
X	Xa	Xb	Xc	Xd	Xe	Xf
Y	Ya	Yb	Yc	Yd	Ye	Yf
Z	Za	Zb	Zc	Zd	Ze	Zf

For coding details and referencing, see page M5.

To order keys, see Accessories on page M30.

OMRON AUTOMATION AND SAFETY • THE AMERICAS HEADQUARTERS • Chicago, IL USA • 847.843.7900 • 800.556.6766 • www.omron247.com

OMRON CANADA, INC. • HEAD OFFICE

Toronto, ON, Canada • 416.286.6465 • 866.986.6766 • www.omron247.com

OMRON ELECTRONICS DE MEXICO • HEAD OFFICE

México DF • 52.55.59.01.43.00 • 01-800-226-6766 • mela@omron.com

OMRON ELECTRONICS DE MEXICO • SALES OFFICE

Apodaca, N.L. • 52.81.11.56.99.20 • 01-800-226-6766 • mela@omron.com

OMRON ELETRÔNICA DO BRASIL LTDA • HEAD OFFICE

São Paulo, SP, Brasil • 55.11.2101.6300 • www.omron.com.br

OMRON ARGENTINA • SALES OFFICE

Cono Sur • 54.11.4783.5300

OMRON CHILE • SALES OFFICE

Santiago • 56.9.9917.3920

OTHER OMRON LATIN AMERICA SALES

54.11.4783.5300

OMRON EUROPE B.V. • Wegalaan 67-69, NL-2132 JD, Hoofddorp, The Netherlands. • +31 (0) 23 568 13 00 • www.industrial.omron.eu

Authorized Distributor:

Automation Control Systems

- Machine Automation Controllers (MAC) • Programmable Controllers (PLC)
- Operator interfaces (HMI) • Distributed I/O • Software

Drives & Motion Controls

- Servo & AC Drives • Motion Controllers & Encoders

Temperature & Process Controllers

- Single and Multi-loop Controllers

Sensors & Vision

- Proximity Sensors • Photoelectric Sensors • Fiber-Optic Sensors
- Amplified Photomicrosensors • Measurement Sensors
- Ultrasonic Sensors • Vision Sensors

Industrial Components

- RFID/Code Readers • Relays • Pushbuttons & Indicators
- Limit and Basic Switches • Timers • Counters • Metering Devices
- Power Supplies

Safety

- Laser Scanners • Safety Mats • Edges and Bumpers • Programmable Safety Controllers • Light Curtains • Safety Relays • Safety Interlock Switches