



Chipsmall Limited consists of a professional team with an average of over 10 year of expertise in the distribution of electronic components. Based in Hongkong, we have already established firm and mutual-benefit business relationships with customers from,Europe,America and south Asia,supplying obsolete and hard-to-find components to meet their specific needs.

With the principle of “Quality Parts,Customers Priority,Honest Operation,and Considerate Service”,our business mainly focus on the distribution of electronic components. Line cards we deal with include Microchip,ALPS,ROHM,Xilinx,Pulse,ON,Everlight and Freescale. Main products comprise IC,Modules,Potentiometer,IC Socket,Relay,Connector.Our parts cover such applications as commercial,industrial, and automotives areas.

We are looking forward to setting up business relationship with you and hope to provide you with the best service and solution. Let us make a better world for our industry!



Contact us

Tel: +86-755-8981 8866 Fax: +86-755-8427 6832

Email & Skype: info@chipsmall.com Web: www.chipsmall.com

Address: A1208, Overseas Decoration Building, #122 Zhenhua RD., Futian, Shenzhen, China



January 16, 1998

TEL:805-498-2111 FAX:805-498-3804 WEB:http://www.semtech.com

STANDARD RECOVERY, PCB MOUNTING, 1-PHASE FULL WAVE BRIDGE RECTIFIER ASSEMBLIES

QUICK REFERENCE DATA

- Low forward voltage drop
- Low reverse leakage current
- Subminiature design
- Three lead configurations
- Pcb mounting

- $V_R = 200V - 1000V$
- $I_F = 1.5A$
- $I_R = 2.0 \mu A$
- $t_{rr} = 2.0\mu S$

ABSOLUTE MAXIMUM RATINGS & CHARACTERISTICS

Device Type	Working Reverse Voltage V_{RWM}	Average Rectified Current $I_F(AV)$		1 Cycle Surge Current I_{FSM} $t_p = 8.3mS$	Repetitive Surge Current I_{FRM}	Reverse Leakage Current $I_R @ V_{RWM}$		Forward Voltage drop $V_f @ 1A/leg$ $@ 25^\circ C$	Reverse Recovery Time t_{rr}
		@ 55°C	@ 100°C	@ 25°C	@ 25°C	@ 25°C	@ 100°C		@ 25°C
		Volts	Amps	Amps	Amps	Amps	μA	μA	Volts
SBM*2	200	1.5	1.0	50	10	2.0	50	1.1	2.0
SBM*4	400	1.5	1.0	50	10	2.0	50	1.1	
SBM*6	600	1.5	1.0	50	10	2.0	50	1.1	
SBM*8	800	1.5	1.0	50	10	2.0	50	1.1	
SBM*0	1000	1.5	1.0	50	10	2.0	50	1.1	

* Add A, B, C for desired circuit configuration
(see Mechanical outline)

¹ Measured on discrete devices prior to assembly

MECHANICAL

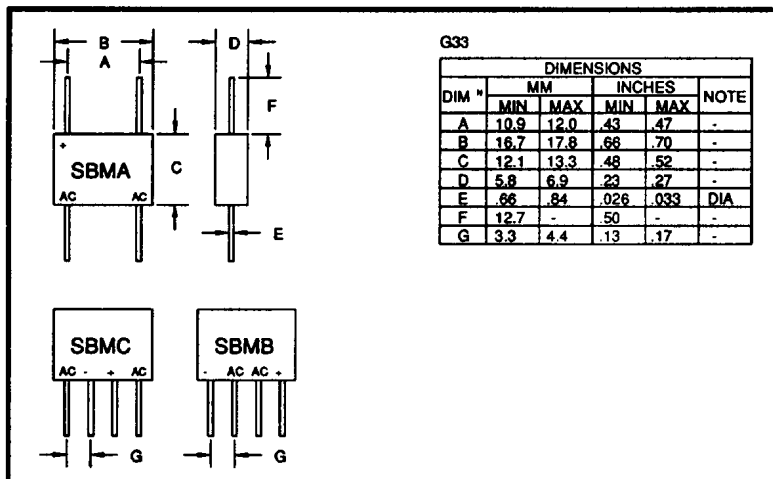

January 16, 1998

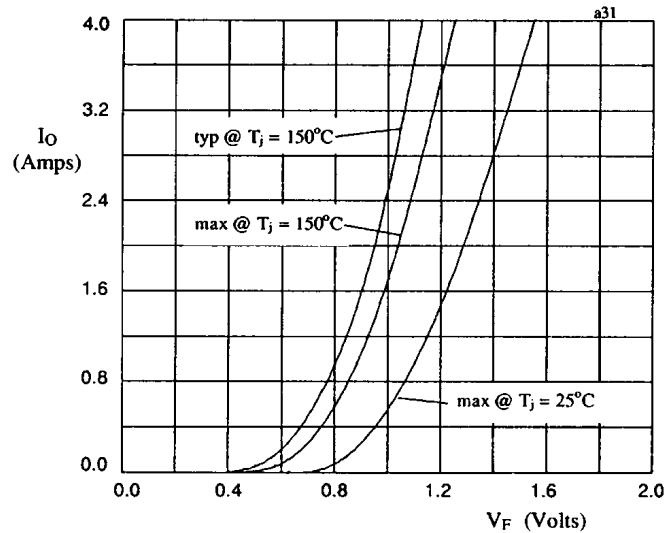

Fig 1. Forward voltage drop against output current per leg

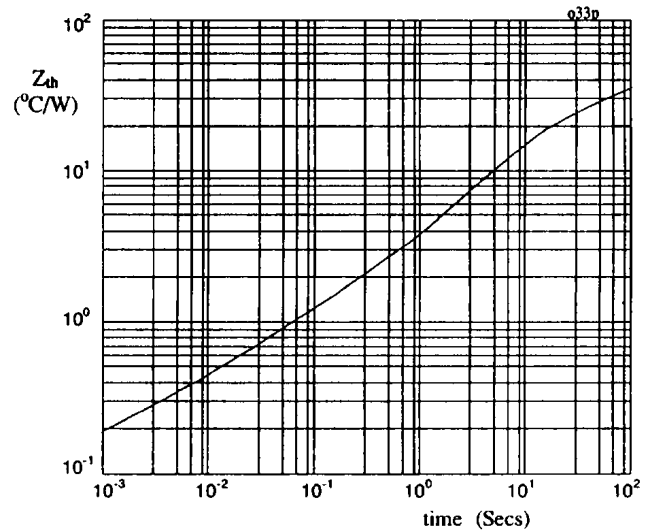

Fig 2. Transient thermal impedance characteristic per leg

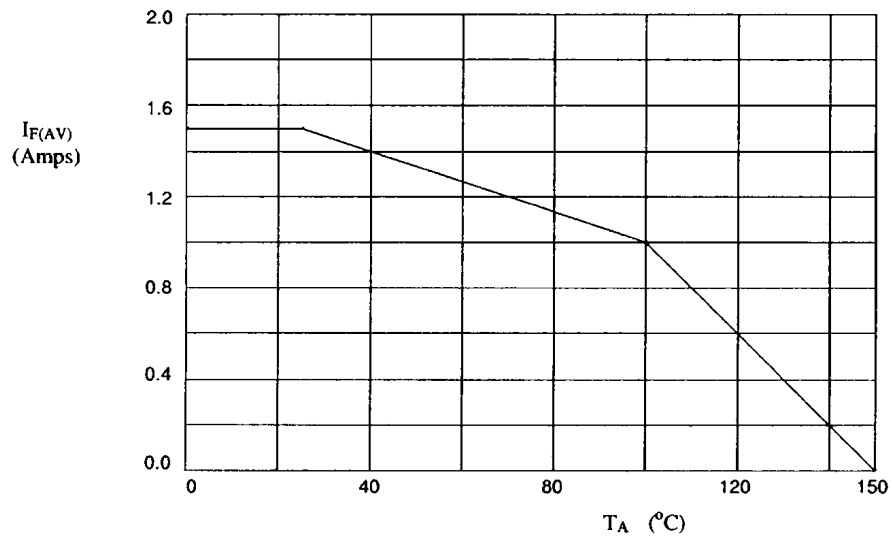

Fig 3. Maximum average forward current against ambient temperature.