



Chipsmall Limited consists of a professional team with an average of over 10 year of expertise in the distribution of electronic components. Based in Hongkong, we have already established firm and mutual-benefit business relationships with customers from,Europe,America and south Asia,supplying obsolete and hard-to-find components to meet their specific needs.

With the principle of “Quality Parts,Customers Priority,Honest Operation,and Considerate Service”,our business mainly focus on the distribution of electronic components. Line cards we deal with include Microchip,ALPS,ROHM,Xilinx,Pulse,ON,Everlight and Freescale. Main products comprise IC,Modules,Potentiometer,IC Socket,Relay,Connector.Our parts cover such applications as commercial,industrial, and automotives areas.

We are looking forward to setting up business relationship with you and hope to provide you with the best service and solution. Let us make a better world for our industry!



Contact us

Tel: +86-755-8981 8866 Fax: +86-755-8427 6832

Email & Skype: info@chipsmall.com Web: www.chipsmall.com

Address: A1208, Overseas Decoration Building, #122 Zhenhua RD., Futian, Shenzhen, China





SC-DUALCON-3

MAINS POWERED

ISOLATING SIGNAL CONVERTER



CAUTION:

This equipment is designed for connection to mains voltages and must be used in accordance with this guide. If it is not, the safety protection provided by the equipment may be impaired.

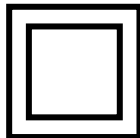

This equipment relies on double / reinforced insulation for safety and does not require a protective earth.

Whilst every effort has been taken to ensure the accuracy of this document, we accept no responsibility for damage, injury, loss or expense resulting from errors or omissions, and reserve the right of amendment without notice.

Cynergy3 Components

This document is issued by Cynergy3 Components Ltd and may not be reproduced in any way without the prior written permission of the company.

July 2017

CONTENTS

1. INTRODUCTION	3
1.1 Hardware Features	3
1.1.1 Isolation Details	3
2. UNPACKING	3
3. CONNECTIONS	4
4. CONFIGURING THE SC-DUALCON	5
4.1.1 Voltage Input:	6
4.1.2 Current Input	7
4.1.3 Millivolt (mV) Input	8
4.1.4 Potentiometer Input	9
4.1.5 Thermocouple Input	10
4.1.6 RTD Input	11
4.1.7 Output Configuration	12
5. CALIBRATING THE SC-DUALCON	13
6. INSTALLATION	14
7. TROUBLESHOOTING	15
7.1 Incorrect Reading	15
7.2 Sensor Failure	15
8. SPECIFICATIONS (@ 25°C)	16

Cynergy3 Components Ltd, Ferndown Industrial Estate,
Wimborne, Dorset, BH17 9FE, UK
Tel: 01202 897969, Fax: 01202 891918
sales@cynergy3.com
www.cynergy3.com

1. INTRODUCTION

1.1 Hardware Features

The SC-DUALCON-3 is a universal input Isolating Signal Converter. It can accept virtually every type of analogue input signal from millivolts to 40Vdc, mA, thermocouples, RTD's etc. It also produces 3 types of analogue output; voltage, mA source, or mA sink on either of 2 analogue outputs. The unit can be powered by any AC voltage between 90 and 264Vac at 50 or 60Hz. For DC voltage the SC-DUALCON-6 is available which can be powered from any supply from 16 to 36Vdc or 18 to 32Vac.

The instrument is packaged in a very compact 17.5mm wide enclosure which can be mounted on standard TS35 DIN-rail.

1.1.1 Isolation Details

The SC-DUALCON-3 has full 3 port isolation of 1000V between the Input Stage, Output Stage 1, Output Stage 2 and Power Supply. The process input and output are double insulated internally from the power supply for safety reasons. Additionally the process input and output are isolated from each other for functional reasons.

2. UNPACKING

The instrument should be carefully inspected for signs of damage which may have occurred in transit. In the unlikely case that damage has been sustained, DO NOT use the instrument, as the safety insulation may have been compromised, but please retain all packaging for our inspection and contact your supplier immediately.

The instrument comes with the following items as standard:

- 1 SC-DUALCON-3 Isolating Signal Converter
- 1 SC-DUALCON-3 User Guide

If the instrument has been factory configured the input and output details will be listed on the Serial number label on the side of the unit. If this label is blank then the unit will be set to its default configuration which is 4-20mA input and 2, 4-20mA source outputs. Please check that the details on the side label are correct, especially the power supply voltage and frequency.

If re-configuration is required please refer to Section 4 of this manual.

3. CONNECTIONS

The SC-DUALCON is housed in a compact DIN rail mounting enclosure, with 12 terminals, arranged in 4 rows of 3 terminals. Two rows are at the top of the front panel and 2 rows are at the bottom. All the sensor input terminals are on the bottom rows together with the second analogue output, and the power supply and first analogue output are on the top terminals.

The diagram below shows how to connect all the different input, output and power supply types.

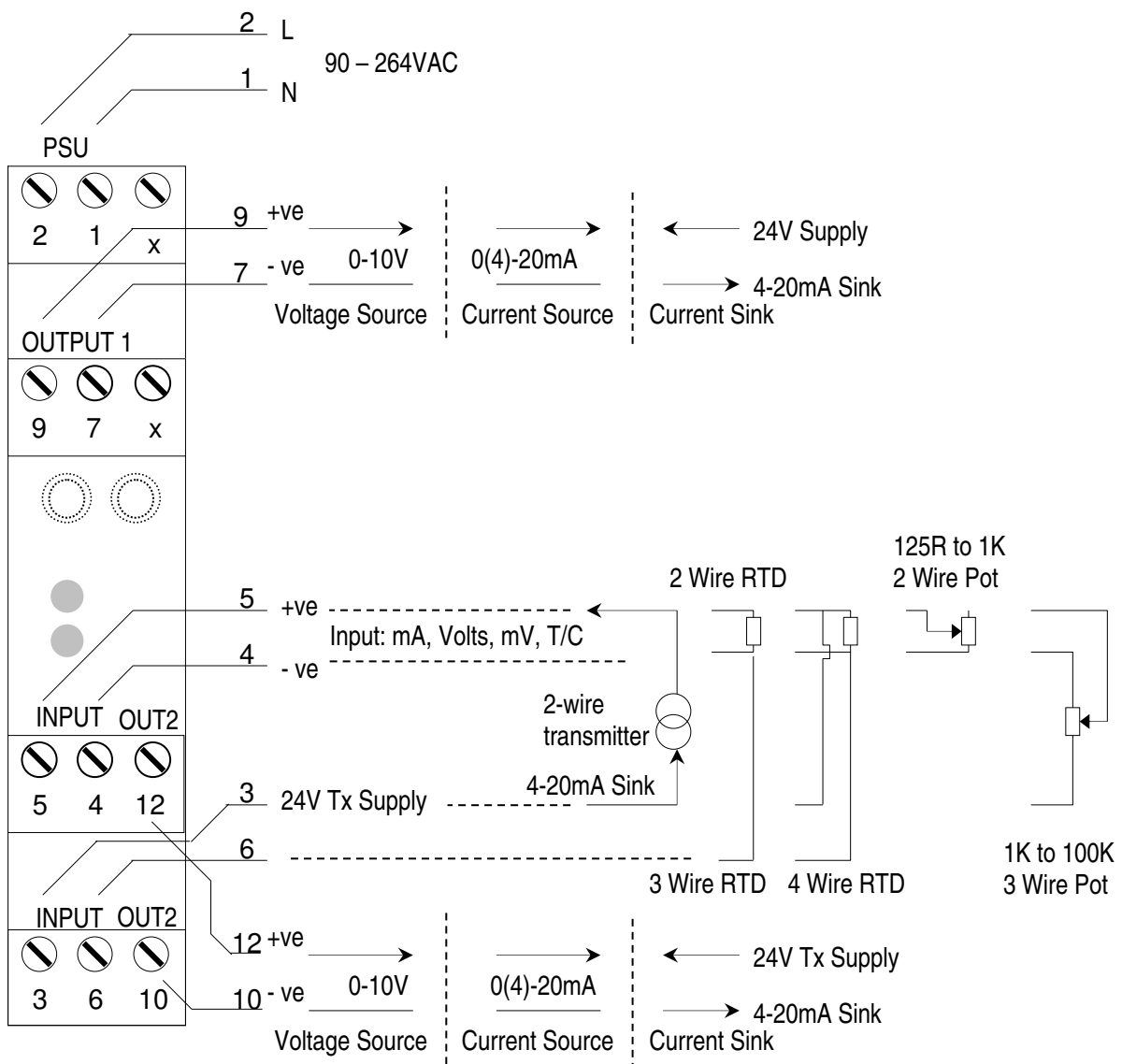

4. CONFIGURING THE SC-DUALCON



! WARNING !
DO NOT OPEN UNIT OR ADJUST SWITCHES WITH
POWER SUPPLY, INPUT OR OUTPUT CONNECTED

The SC-DUALCON is an extremely versatile device which can support many different types of input. The unit is configured by turning the power off, selecting the internal switch settings required and turning the power back on.

To open the SC-DUALCON, 2 catches just below the outer terminal blocks must be pushed in gently, one at a time. The front of the case can then be pulled and the unit will come out of the box.



Press here gently

There are 4 switch banks, S1, S2, S3 and S4, located inside the SC-DUALCON as shown below:

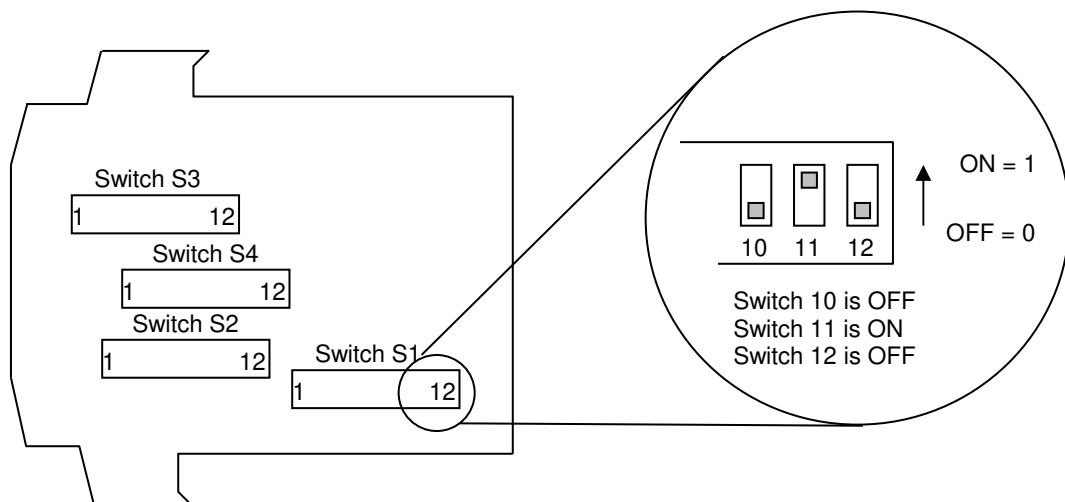

Switch S1 and S2 configure the input type and range, and switch S3 and S4 configure the output types, ranges and a few additional functions. The switch settings are explained in the next few pages. The diagrams refer to switch positions 0 and 1, with 0 being OFF and 1 being ON. This is illustrated in the picture above.

4.1.1 Voltage Input:

Select the range from the table below and set Switch S1 to the required values.

Voltage Range	Switch S1											
	1	2	3	4	5	6	7	8	9	10	11	12
0-1V	0	0	0	0	0	1	0	0	1	1	0	0
0-2V	0	0	0	1	}							0
0-4V	0	0	1	0								0
0-5V	0	1	0	0								0
0-7.5V	1	0	0	0								0
0-8V	0	0	1	1								0
0-10V	0	1	0	1								0
0-15V	1	0	0	1								0
0-20V	0	1	1	0								0
0-30V	1	0	1	0								0
0-40V	0	1	1	1								0
1-5V	0	1	0	0								0
-5 to +5V	1	1	0	0								0
-10 to +10V	1	1	0	1	0	1	0	0	1	1	0	0

Then select the required setting from the table below for switch S2

Voltage Range	Switch S2											
	1	2	3	4	5	6	7	8	9	10	11	12
0-30V & 0-40V Ranges	0	0	1	1	0	0	1	1	0	0	0	0
All other Ranges Listed Above	0	0	1	0	1	0	1	0	0	0	0	0



! WARNING !
DO NOT OPEN UNIT OR ADJUST SWITCHES WITH POWER SUPPLY, INPUT OR OUTPUT CONNECTED

Please note that PC Software is available to provide information on switch settings for your input and output requirements.

4.1.2 Current Input

Select the range from the table below and set Switch S1 to the required values.

mA Range	Switch S1											
	1	2	3	4	5	6	7	8	9	10	11	12
0-1mA	0	0	0	0	0	0	0	0	1	1	1	0
0-2mA	0	0	0	1								0
0-4mA	0	0	1	0								0
0-5mA	0	1	0	0								0
0-8mA	0	0	1	1								0
0-10mA	0	1	0	1								0
0-15mA	1	0	0	1								0
0-20mA	0	1	1	0								0
0-30mA	1	0	1	0								0
4-20mA	0	1	1	0								1
4-40mA	0	1	1	1								1
4-30mA	1	0	1	0	1							
-5 to +5mA	1	1	0	0	0	0	0	1	1	1	0	
-10 to +10mA	1	1	0	1	0	0	0	0	1	1	1	0

Then select the required setting from the table below for switch S2

mA Range	Switch S2											
	1	2	3	4	5	6	7	8	9	10	11	12
Using Internal 24V Tx Supply for 4 to 20mA	1	1	0	1	0	0	1	1	0	0	1	0
Unipolar Ranges (e.g. 0-20mA, 4-20mA)	1	1	0	0	0	0	1	1	0	0	0	0
Bipolar Ranges (e.g. -10 to +10mA)	1	1	0	0	1	0	1	0	0	0	0	0



! WARNING !
DO NOT OPEN UNIT OR ADJUST SWITCHES WITH POWER SUPPLY, INPUT OR OUTPUT CONNECTED

Please note that PC Software is available to provide information on switch settings for your input and output requirements.

4.1.3 Millivolt (mV) Input

Select the range from the table below and set Switch S1 to the required values.

mV Range	Switch S1											
	1	2	3	4	5	6	7	8	9	10	11	12
0-25mV	0	0	0	0	0	0	0	1	1	1	0	0
0-50mV	0	0	0	1								
0-100mV	0	0	1	0								
0-125mV	0	1	0	0								
0-150mV	1	0	0	0								
0-200mV	0	0	1	1								
0-250mV	0	1	0	1								
0-300mV	1	0	0	1								
0-500mV	0	1	1	0								
0-600mV	1	0	1	0								
0-1000mV	0	1	1	1								
0-1200mV	1	0	1	1								
-125 to +125mV	1	1	0	0								
-125 to +1000mV	1	1	1	1	0	0	0	1	1	1	0	0

And then select the required setting from the table below for switch S2

mV Range	Switch S2											
	1	2	3	4	5	6	7	8	9	10	11	12
All Unipolar Ranges (e.g. 0-500mV)	0	1	0	0	0	0	1	1	0	0	0	0
Bipolar Ranges (e.g. -125 to +125mV)	0	1	0	0	1	0	1	0	0	0	0	0



! WARNING !
DO NOT OPEN UNIT OR ADJUST SWITCHES WITH POWER SUPPLY, INPUT OR OUTPUT CONNECTED

Please note that PC Software is available to provide information on switch settings for your input and output requirements.

4.1.4 Potentiometer Input

Select the range from the table below and set Switch S1 to the required values.

Potentiometer Input	Switch S1											
	1	2	3	4	5	6	7	8	9	10	11	12
2 Wire 0-125R	0	0	0	0	0	0	0	1	1	1	0	1
2 Wire 0-250R	0	0	0	1								
2 Wire 0-500R	0	0	1	0								
2 Wire 0-625R	0	1	0	0								
2 Wire 0-750R	1	0	0	0								
2 Wire 0-1K	0	0	1	1	0	0	0	1	1	1	0	1
3 Wire from 0-1K to 0-100K	0	0	0	0	0	1	0	1	1	1	1	0

Then select the required setting from the table below for switch S2

Potentiometer Input	Switch S2											
	1	2	3	4	5	6	7	8	9	10	11	12
2 Wire Potentiometer	0	1	0	0	1	0	0	1	0	0	0	1
3 Wire Potentiometer	0	0	1	1	0	0	1	1	0	0	1	0



! WARNING !
DO NOT OPEN UNIT OR ADJUST SWITCHES WITH POWER SUPPLY, INPUT OR OUTPUT CONNECTED

Please note that PC Software is available to provide information on switch settings for your input and output requirements.

4.1.5 Thermocouple Input

Select the range from the table below and set Switch S1 to the required values.

Switch S1 for Thermocouple Input																				
Temperature Range in °C			Switch									T/C Type								
K	J	R	S	N	E	B	T	1	2	3	4		5	6	7	8	9	10	11	12
0 to 100	400 to 500	0 to 50	0	0	0	0	0	0	0	0	0	0	0	0	0	0	0	0	0	0
0 to 200	400 to 600	0 to 100	0	0	0	0	1	0	0	0	0	0	0	0	0	0	0	0	0	0
0 to 400	400 to 800	0 to 200	0	0	0	1	0	0	0	0	0	0	0	0	0	0	0	0	0	0
0 to 800	400 to 1200	0 to 400	0	0	0	1	1	0	0	0	0	0	0	0	0	0	0	0	0	0
0 to 125	400 to 525	-50 to 50	0	1	0	0	0	0	0	0	0	0	0	0	0	0	0	0	0	0
0 to 250	400 to 650	-50 to 100	0	1	0	0	1	0	0	0	0	0	0	0	0	0	0	0	0	0
0 to 500	400 to 900	-50 to 200	0	1	1	0	0	0	0	0	0	0	0	0	0	0	0	0	0	0
0 to 1000	400 to 1400	-50 to 400	0	1	1	1	0	0	0	0	0	0	0	0	0	0	0	0	0	0
0 to 150	400 to 550	-100 to 50	1	0	0	0	0	0	0	0	0	0	0	0	0	0	0	0	0	0
0 to 300	400 to 700	-100 to 100	1	0	0	0	1	0	0	0	0	0	0	0	0	0	0	0	0	0
0 to 600	400 to 1000	-100 to 200	1	0	1	0	0	0	0	0	0	0	0	0	0	0	0	0	0	0
0 to 1200*	400 to 1600	-100 to 400	1	0	1	1	0	0	0	0	0	0	0	0	0	0	0	0	0	0
0 to 175	400 to 575	-200 to 50	1	1	0	0	0	0	0	0	0	0	0	0	0	0	0	0	0	0
0 to 350	400 to 750	-200 to 100	1	1	0	0	1	0	0	0	0	0	0	0	0	0	0	0	0	0
0 to 700	400 to 1100	-200 to 200	1	1	1	0	0	0	0	0	0	0	0	0	0	0	0	0	0	0
0 to 1400**	400 to 1800	-200 to 400	1	1	1	1	0	0	0	0	0	0	0	0	0	0	0	0	0	0

Linearisation ON	0
Linearisation off	1

CJC ON	0
CJC off	1

Then select the required setting from the table below for switch S2

Thermocouple	Switch S2											
	1	2	3	4	5	6	7	8	9	10	11	12
All Ranges	0	1	0	0	1	1	1	0	0	0	0	0



! WARNING !
DO NOT OPEN UNIT OR ADJUST SWITCHES WITH POWER SUPPLY, INPUT OR OUTPUT CONNECTED

Please note that PC Software is available to provide information on switch settings for your input and output requirements.

4.1.6 RTD Input

Select the range from the table below and set Switch S1 to the required values.

Range in °C	Switch S1											
	1	2	3	4	5	6	7	8	9	10	11	12
0 to 100	0	0	0	0		0	0	1	0	0		
0 to 200	0	0	0	1		0	0	1	0	0		
0 to 400	0	0	1	0		0	0	1	0	0		
0 to 800	0	0	1	1		0	0	1	0	0		
-50 to 50	0	1	0	0		0	0	1	0	0		
-50 to 150	0	1	0	1		0	0	1	0	0		
-50 to 250	0	1	1	0		0	0	1	0	0		
-50 to 350	0	1	1	1		0	0	1	0	0		
-100 to 50	1	0	0	0		0	0	1	0	0		
-100 to 100	1	0	0	1		0	0	1	0	0		
-100 to 200	1	0	1	0		0	0	1	0	0		
-100 to 400	1	0	1	1		0	0	1	0	0		
-200 to 200	1	1	0	0		0	0	1	0	0		
-200 to 400	1	1	0	1		0	0	1	0	0		
-200 to 600	1	1	1	0		0	0	1	0	0		
-200 to 800	1	1	1	1		0	0	1	0	0		

RTD linearisation ON	0
RTD linearisation off	1

PT100	0
PT1000	1

RTD 2 or 4 wire	0
RTD 3 wire	1

And then select the required setting from the table below for switch S2

RTD	Switch S2											
	1	2	3	4	5	6	7	8	9	10	11	12
2 Wire RTD	0	1	0	0	1	0	0	1	0	0	0	1
3 Wire RTD	0	1	0	0	0	0	0	0	1	0	0	1
4 Wire RTD	0	1	0	0	0	0	0	1	0	1	0	0



! WARNING !
DO NOT OPEN UNIT OR ADJUST SWITCHES WITH POWER SUPPLY, INPUT OR OUTPUT CONNECTED

Please note that PC Software is available to provide information on switch settings for your input and output requirements.

4.1.7 Output Configuration

Select the range for Output 1 from the table below and set Switch S3 to the required values.

Switch S3 - Output Configuration																																																
1	2	3	4	5	6	7	8	9	10	11	12																																					
↓	<table style="width:100%; border-collapse: collapse;"> <tr><td style="width: 15px;">0</td><td>1</td><td>0</td><td>1</td><td>0</td><td>mA Source</td></tr> <tr><td>1</td><td>0</td><td>1</td><td>0</td><td>0</td><td>mA Sink</td></tr> <tr><td>0</td><td>1</td><td>0</td><td>1</td><td>1</td><td>Voltage</td></tr> </table>					0	1	0	1	0	mA Source	1	0	1	0	0	mA Sink	0	1	0	1	1	Voltage	↓	<table style="width:100%; border-collapse: collapse;"> <tr><td style="width: 15px;">0</td><td>Normal</td></tr> <tr><td>1</td><td>Inverted o/p</td></tr> </table>		0	Normal	1	Inverted o/p	↓	0	↓	1	<table style="width:100%; border-collapse: collapse;"> <tr><td style="width: 15px;">4-20mA / 2-10V</td><td>0</td><td>0</td></tr> <tr><td>0-20mA / 0-10V</td><td>0</td><td>1</td></tr> <tr><td>0-10mA / 0-5V</td><td>1</td><td>0</td></tr> <tr><td>2-10mA / 1-5V</td><td>1</td><td>1</td></tr> </table>		4-20mA / 2-10V	0	0	0-20mA / 0-10V	0	1	0-10mA / 0-5V	1	0	2-10mA / 1-5V	1	1
0	1	0	1	0	mA Source																																											
1	0	1	0	0	mA Sink																																											
0	1	0	1	1	Voltage																																											
0	Normal																																															
1	Inverted o/p																																															
4-20mA / 2-10V	0	0																																														
0-20mA / 0-10V	0	1																																														
0-10mA / 0-5V	1	0																																														
2-10mA / 1-5V	1	1																																														
<table style="width:100%; border-collapse: collapse;"> <tr><td style="width: 15px;">0</td><td>Buttons Disabled</td></tr> <tr><td>1</td><td>Buttons Enabled</td></tr> </table>		0	Buttons Disabled	1	Buttons Enabled	<table style="width:100%; border-collapse: collapse;"> <tr><td style="width: 15px;">High Burnout</td><td>0</td></tr> <tr><td>Low Burnout</td><td>1</td></tr> </table>		High Burnout	0	Low Burnout	1	Output value if fault on input signal																																				
0	Buttons Disabled																																															
1	Buttons Enabled																																															
High Burnout	0																																															
Low Burnout	1																																															
Front panel buttons can be disabled to allow tamper-proof operation of the unit																																																

Examples:

Switch S3 Examples												
	1	2	3	4	5	6	7	8	9	10	11	12
4-20mA Source	1	0	1	0	1	0	0	0	0	1	0	0
0-20mA Source	1	0	1	0	1	0	0	0	0	1	0	1
0-10V	1	0	1	0	1	1	0	0	0	1	0	1
4-20mA Sink	1	1	0	1	0	0	0	0	0	1	0	0

Repeat the process for Output 2 using the table below for switch S4:

Switch S4 - Output 2 Configuration																																														
1	2	3	4	5	6	7	8	9	10	11	12																																			
↓	<table style="width:100%; border-collapse: collapse;"> <tr><td style="width: 15px;">0</td><td>1</td><td>0</td><td>1</td><td>0</td><td>mA Source</td></tr> <tr><td>1</td><td>0</td><td>1</td><td>0</td><td>0</td><td>mA Sink</td></tr> <tr><td>0</td><td>1</td><td>0</td><td>1</td><td>1</td><td>Voltage</td></tr> </table>					0	1	0	1	0	mA Source	1	0	1	0	0	mA Sink	0	1	0	1	1	Voltage	↓	<table style="width:100%; border-collapse: collapse;"> <tr><td style="width: 15px;">0</td><td>Normal</td></tr> <tr><td>1</td><td>Inverted o/p</td></tr> </table>		0	Normal	1	Inverted o/p	↓	1	<table style="width:100%; border-collapse: collapse;"> <tr><td style="width: 15px;">4-20mA / 2-10V</td><td>0</td><td>0</td></tr> <tr><td>0-20mA / 0-10V</td><td>0</td><td>1</td></tr> <tr><td>0-10mA / 0-5V</td><td>1</td><td>0</td></tr> <tr><td>2-10mA / 1-5V</td><td>1</td><td>1</td></tr> </table>		4-20mA / 2-10V	0	0	0-20mA / 0-10V	0	1	0-10mA / 0-5V	1	0	2-10mA / 1-5V	1	1
0	1	0	1	0	mA Source																																									
1	0	1	0	0	mA Sink																																									
0	1	0	1	1	Voltage																																									
0	Normal																																													
1	Inverted o/p																																													
4-20mA / 2-10V	0	0																																												
0-20mA / 0-10V	0	1																																												
0-10mA / 0-5V	1	0																																												
2-10mA / 1-5V	1	1																																												
<table style="width:100%; border-collapse: collapse;"> <tr><td style="width: 15px;">1</td><td>Buttons Enabled</td></tr> </table>		1	Buttons Enabled	<table style="width:100%; border-collapse: collapse;"> <tr><td style="width: 15px;">High Burnout</td><td>0</td></tr> <tr><td>Low Burnout</td><td>1</td></tr> </table>		High Burnout	0	Low Burnout	1	Output value if fault on input signal																																				
1	Buttons Enabled																																													
High Burnout	0																																													
Low Burnout	1																																													



! WARNING !
DO NOT OPEN UNIT OR ADJUST SWITCHES WITH POWER SUPPLY, INPUT OR OUTPUT CONNECTED

Please note that PC Software is available to provide information on switch settings for your input and output requirements.

5. CALIBRATING THE SC-DUALCON

When the unit is shipped the SC-DUALCON will be calibrated for the input and output types and ranges noted on the side label. If this label is blank then the unit will be calibrated for 4-20mA input and 2 x 4-20mA source outputs. If the unit is re-ranged by the user it is necessary to re-calibrate the unit to obtain the maximum accuracy. The calibration is achieved by using both switches on the front panel to select the zero or span adjust mode and then using the switches as raise/lower buttons to adjust the output to the value required.

The mode the unit is in is indicated by the colour of the LED's for both channels:

Green	-	Normal Operation
Red	-	Span Adjust
Yellow	-	Zero Adjust

Setting of the zero and span points is non-interactive, so each point need only be set once. A typical calibration sequence would be as follows:

LED CH1	LED CH2	Mode	Action
Green	Green	Normal	Apply full scale input. Press and release both buttons together to enter output 1 span mode
RED	Green	Output 1 Span Adjust	Press raise / lower buttons to adjust output 1 value. Press and release both buttons together to return to normal mode
Green	Green	Normal	Apply zero scale input Press and release both buttons together to enter output 1 zero mode
YELLOW	Green	Output 1 Zero Adjust	Press raise / lower buttons to adjust output value. Press and release both buttons together to return to normal mode
Green	Green	Normal	Apply full scale input. Press and release both buttons together to enter output 2 span mode
Green	RED	Output 2 Span Adjust	Press raise / lower buttons to adjust output 2 value. Press and release both buttons together to return to normal mode
Green	Green	Normal	Apply zero scale input Press and release both buttons together to enter output 2 zero mode
Green	YELLOW	Output 2 Zero Adjust	Press raise / lower buttons to adjust output 2 value. Press and release both buttons together to return to normal mode
Green	Green	Normal	Use product

The unit is now calibrated and ready for use.

Note: The unit will retain the new settings on power down.

When the unit is used to convert a thermocouple input it is important when calibrating to ensure that the thermocouple simulator employed is switched to automatic cold junction compensation and is at the same ambient temperature as the SC-DUALCON. Note that this is not always easy to achieve, especially if the SC-DUALCON is mounted in a warm cabinet. An alternative method is to use an ice-point reference and a mV source.

6. INSTALLATION

The SC-DUALCON's input and output circuits are classed as Separated Extra Low Voltage (SELV). This means that they must not be externally connected to voltages exceeding 30V ac or 60V dc, nor do they generate voltages above these limits internally. Where a higher voltage input is required a specially designed DIVIDER unit can be used to condition the input signal prior to connection to the process input terminals.

The SC-DUALCON unit clips directly onto 'Top Hat' (TS35) symmetrical DIN rail. Ideally, mounting orientation should be vertical, with the power supply situated on the top face to minimise temperature rise. Good airflow around the unit will maximise reliability of the instrument.

The use of bootlace ferrules is recommended on wiring terminations. Do not exceed terminal torque rating of 0.4 Nm – use an appropriate screwdriver. The unit can be removed from the DIN rail by sliding a small screwdriver into the slot at the rear of the enclosure on the lower face and gently levering the metal clip, whilst lifting the unit from the rail.

Although the unit is protected by a non-resettable internal fuse, it is essential that the following provisions are made in the installation:

An anti-surge fuse with a voltage rating of 250V ac and a breaking capacity of 35A at 250V ac shall be wired in series with the supply live conductor (terminal 2). For 230V supplies T63mA should be used and for 115V supplies T125mA should be used. An appropriately marked or labelled switch or circuit breaker meeting the requirements of IEC947-1 and IEC947-3 shall be included in the supply installation in close proximity to the equipment, within easy reach of the operator. The supply neutral (terminal 1) should be connected to the mains supply neutral.

7. TROUBLESHOOTING

The SC-DUALCON has some built in self diagnostic functions. If the LED's on the front panel are flashing then the fault mode can be found by counting the number of flashes between gaps and using the table below to locate the problem.

NOTE: Even if the LED is not lit, mains voltages could still be present – ALWAYS isolate the mains supply before removing or examining the unit.

No of Flashes	Nature of Fault	Corrective Action
0 (Green On)	Unit working – no suspected fault	Check wiring and switch settings
2,3,4,5,6,8,9, 10,11,12 Green	Hardware error, extreme noise, poor supply	Switch off unit, check switch settings, and wiring, and retry. If still faulty please contact supplier
7 Green	RTD / Thermocouple burnout	Repair RTD, T/C or wiring
3 or 4 Red	Span point is too close to zero point	Change input span value and retry
3 or 4 Yellow	Zero point is too close to span point	Change input zero value and retry
No LED	Power Failure	Check supply lines and voltage

7.1 Incorrect Reading

- Check that Unit is configured for the correct Sensor
- Check that Input Scaling is as required.
- Check that Linearisation has not been set incorrectly.
- Check that Thermocouples have correct compensation cables, and polarity.
- Check that RTD is set for correct option 2, 3 or 4 Wire.
- Check that RTD leads are connected to appropriate terminal pins.

7.2 Sensor Failure

- Check that sensor wiring is correct.
- Check Thermocouple polarity.
- Check that all RTD leads are connected to correct terminals.
- Check that the SC-DUALCON is configured for correct sensor.
- Check that applied voltage is not out of range.
- Check that applied current is not out of range.
- Check that applied millivoltage is not out of range.

8. SPECIFICATIONS (@ 25°C)

Operating Temperature	0 to 55 °C (Storage: -40 to +100°C)
Operating Altitude	Sea Level to 2000m
Humidity	0-90% RH
Power Requirements AC Supply	90 to 264Vac 50 or 60Hz
VA Rating	2.6VA ±10% typ (20mA in & out) 4.7VA ±10% (maximum load)
Transmitter Power Supply	21V to 28V @ up to 24mA Dependant on supply voltage and load
Calibration accuracy	±0.05% full scale
Linearity	±0.05% full scale
Temperature Stability	50ppm / °C
Input Impedance:	
Current Input	15 ohms
Voltage Input	1 Mohm
Millivolt Input	Greater Than 10 Mohm
Thermocouple Burn Out Current:	500nA Nominal
Cold junction compensation accuracy	±0.5°C over operating range
Maximum Voltage Output	11.5 V into a minimum of 7Kohm
Maximum Current Output	23.0 mA into a maximum of 1Kohm
Time Response (90% of step change):	50ms ±10ms

Unit has full 3 port Isolation to 1kV between Power Supply, Input and Outputs.
The unit can also withstand transients of 2.5kV for 50 µsecs.

Dimensions	114.5 mm x 99mm x 17.5mm (H x D x W)
Mounting	DIN Rail TS35
Connections	Screw Clamp with pressure plate
Conductor Size	0.5 to 4.0 mm
Insulation Stripping	12 mm
Maximum Terminal Torque	0.4 Nm
Weight	Approx. 115g
EMC	BS EN61326
LVD Standards	EN61010-1
Installation Category (IEC 664)	II
Pollution Degree (EN61010-1)	2
Equipment Class (IEC 536)	II