



Chipsmall Limited consists of a professional team with an average of over 10 year of expertise in the distribution of electronic components. Based in Hongkong, we have already established firm and mutual-benefit business relationships with customers from,Europe,America and south Asia,supplying obsolete and hard-to-find components to meet their specific needs.

With the principle of “Quality Parts,Customers Priority,Honest Operation,and Considerate Service”,our business mainly focus on the distribution of electronic components. Line cards we deal with include Microchip,ALPS,ROHM,Xilinx,Pulse,ON,Everlight and Freescale. Main products comprise IC,Modules,Potentiometer,IC Socket,Relay,Connector.Our parts cover such applications as commercial,industrial, and automotives areas.

We are looking forward to setting up business relationship with you and hope to provide you with the best service and solution. Let us make a better world for our industry!



## Contact us

Tel: +86-755-8981 8866 Fax: +86-755-8427 6832

Email & Skype: info@chipsmall.com Web: www.chipsmall.com

Address: A1208, Overseas Decoration Building, #122 Zhenhua RD., Futian, Shenzhen, China



### POWER MANAGEMENT

#### Description

The SC104 is a micro power dc-dc step-up converter which converts an input voltage, in the range of 1.55V to 10V, to a constant current. The part features a range of user programmable voltages and currents including dynamic adjustment of the “constant” current. The converter is capable of generating output voltages as low as the input supply voltage and up to 38V. During shutdown, the part draws a typical 500nA standby current.

The output current is set by the external resistor R1. Dynamic adjustment of the output current can be made by the application of an analog voltage to the ADJ input, or by PWMing this pin.

The peak switch current is programmable through the external resistor  $R_{LIM}$  enabling the use of a wide range of inductors and battery technologies.

#### Features

- ◆ Adjustable output current using pulse width modulation or analog voltage input
- ◆ 38V output capability supports up to 10 white LEDs
- ◆ Wide range of input voltages 1.55V to 10V
- ◆ Low quiescent current
- ◆ 0.5 $\mu$ A standby current in shutdown
- ◆ Programmable cycle by cycle current limit
- ◆ Surface mount packaging (3x3mm 8pin MLP)
- ◆ Output voltage and over-temperature protection

#### Applications

- ◆ White LED supplies
- ◆ Color LED supplies
- ◆ Cellular phones
- ◆ PDAs
- ◆ Electronic books
- ◆ Handheld computers
- ◆ Wireless web appliances

#### Typical Application Circuit - 6 LEDs

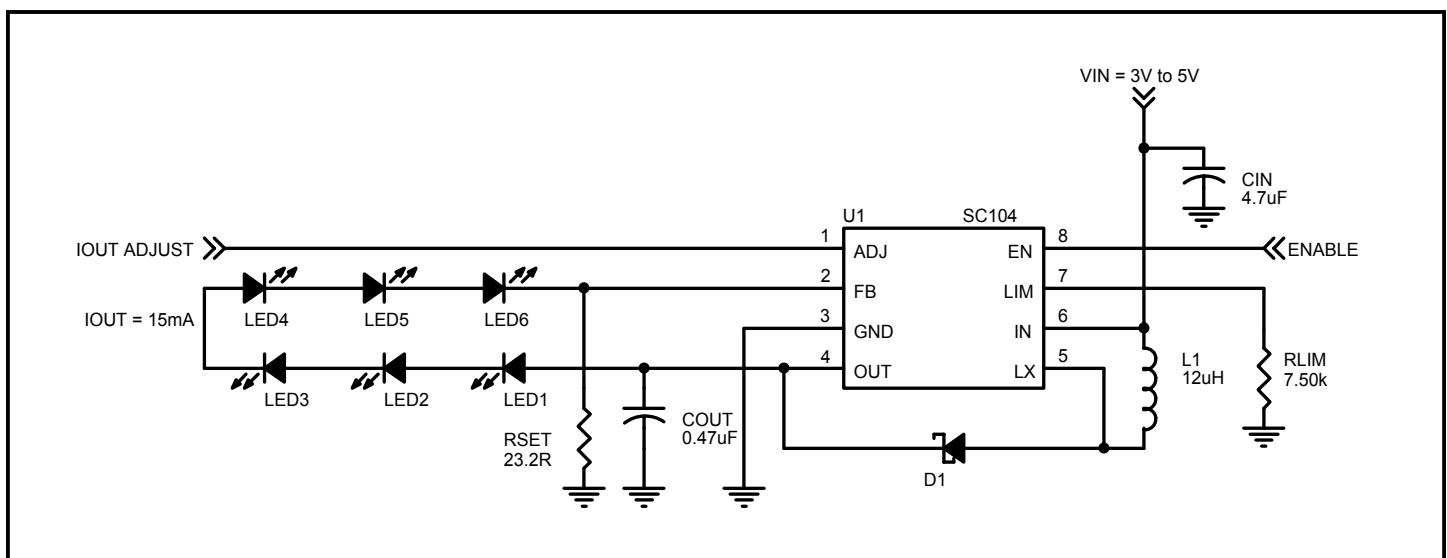

**POWER MANAGEMENT**
**Absolute Maximum Ratings**

Exceeding the specifications below may result in permanent damage to the device, or device malfunction. Operation outside of the parameters specified in the Electrical Characteristics section is not implied.

Parameter	Symbol	Maximum	Units
Input Supply Voltage	$V_{IN}$	-0.3 to 12	V
LX Pin Voltage (Power switch OFF)	$V_{LX}$	-0.3 to 55	V
FB Pin Voltage	$V_{FB}$	-0.3 to 6	V
EN Pin Voltage	$V_{EN}$	-0.3 to 6	V
LIM Pin Voltage	$V_{LIM}$	-0.3 to 6	V
ADJ Pin Voltage	$V_{ADJ}$	-0.3 to 2	V
OUT Pin Voltage	$V_{OUT}$	-0.3 to 55	V
Thermal Impedance Junction to Ambient	$\theta_{JA}$	84	°C/W
Operating Ambient Temperature Range	$T_A$	-40 to +85	°C
Operating Junction Temperature Range	$T_J$	-40 to +125	°C
Storage Temperature Range	$T_{STG}$	-65 to +150	°C
Lead Temperature SC104IMLTR (Soldering) 10s - 30s SC104IMLTRT (Soldering) 20s - 40s	$T_{LEAD}$	240 260	°C
ESD Rating (Human Body Model)	$V_{ESD}$	2	kV

**Electrical Characteristics**

Unless specified:  $V_{IN} = V_{EN} = 2V$ ,  $-40 \leq T_A \leq 85^\circ C$ , typical values are at room temperature.

Parameter	Symbol	Test Conditions	Min	Typ	Max	Units
Input Supply Voltage	$V_{IN}$	$T_A = 25^\circ C$	1.55		10	V
			1.75		10	
Shutdown Current	$I_{Q(OFF)}$	$V_{EN} = 0V$		0.5	3	$\mu A$
Feedback Voltage	$V_{FB}$		340	350	360	mV
Feedback Input Current	$I_{FB}$	$V_{FB} < 350mV$	200	700	1115	nA
Power Switch Saturation Voltage	$V_{CE(SAT)}$	$I_{LX} = 300mA$		150	250	mV
Junction Temperature at Thermal Shutdown <sup>(1)</sup>	$T_{TSD}$		140	150	160	°C
Over-Voltage Protection	$V_{OVP}$	Test current = 10 $\mu A$	36	38	44	V
Adjust Voltage	$V_{ADJ}$	$I_{ADJ} = 0A$	0.97	1.00	1.03	V
Adjust Voltage Switching Inhibit Threshold	$V_{TH(ADJ)}$				100	mV

**POWER MANAGEMENT**
**Electrical Characteristics (Cont.)**

 Unless specified:  $V_{IN} = V_{EN} = 2V$ ,  $-40 \leq T_A \leq 85^\circ C$ , typical values are at room temperature.

Parameter	Symbol	Test Conditions	Min	Typ	Max	Units
Adjust Input Current	$I_{ADJ}$	$V_{ADJ} = 0V$	6	10	20	$\mu A$
		$V_{ADJ} = 1V$	-500	0	500	nA
		$V_{ADJ} = 1.25V$	-1.3	-2.3	-3.8	$\mu A$
Maximum Switch Current	$I_{LX}$	$I_{LIM} = 150\mu A$	-920			mA
Switch Off Time	$t_{OFF}$	$V_{FB} = 300mV$	0.60	0.76	1.00	$\mu s$
		$V_{FB} = 0V$	1.00	1.25	1.60	
Switch On Time	$t_{ON}$	excludes current limited conditions	1.8	2.25	2.7	$\mu s$
Maximum Duty Cycle	$\%_{DC}$		70			%
Switch Leakage	$I_{LX}$	switch off, $V_{LX} = 5V$		-0.01	-1.0	$\mu A$
Voltage Reference for Current Limit Setting Resistor	$V_{LIM}$	$I_{LIM} = 50\mu A$	385	400	410	mV
$I_{LX}$ to $I_{LIM}$ Ratio	$I_{LX} / I_{LIM}$	$I_{LIM} = 50\mu A$	7100	8150	8800	A/A
Logic Inputs						
Enable Input Voltage	$V_{IH}$	$I_{EN} > 300nA$	1.5			V
	$V_{IL}$				0.2	
Enable Input Bias Current	$I_{IL}$	$V_{EN} = 0.3V$			0.3	$\mu A$
	$I_{IH}$	$V_{EN} = 1.3V$			0.7	

**Note:**

(1) Guaranteed by design.

**POWER MANAGEMENT**

**Pin Configuration**

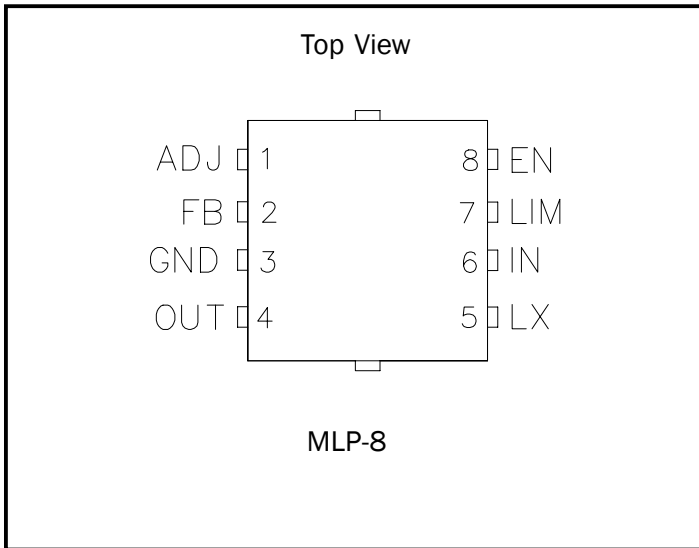

**Ordering Information**

Part Number	Package
SC104IMLTR <sup>(1)</sup>	MLP-8
SC104IMLTRT <sup>(2)</sup>	
SC104EVB	Evaluation Board

Notes:

(1) Only available in tape and reel packaging. A reel contains 3000 devices.

(2) Lead free product. This product is fully WEEE and RoHS compliant.

**Block Diagram**

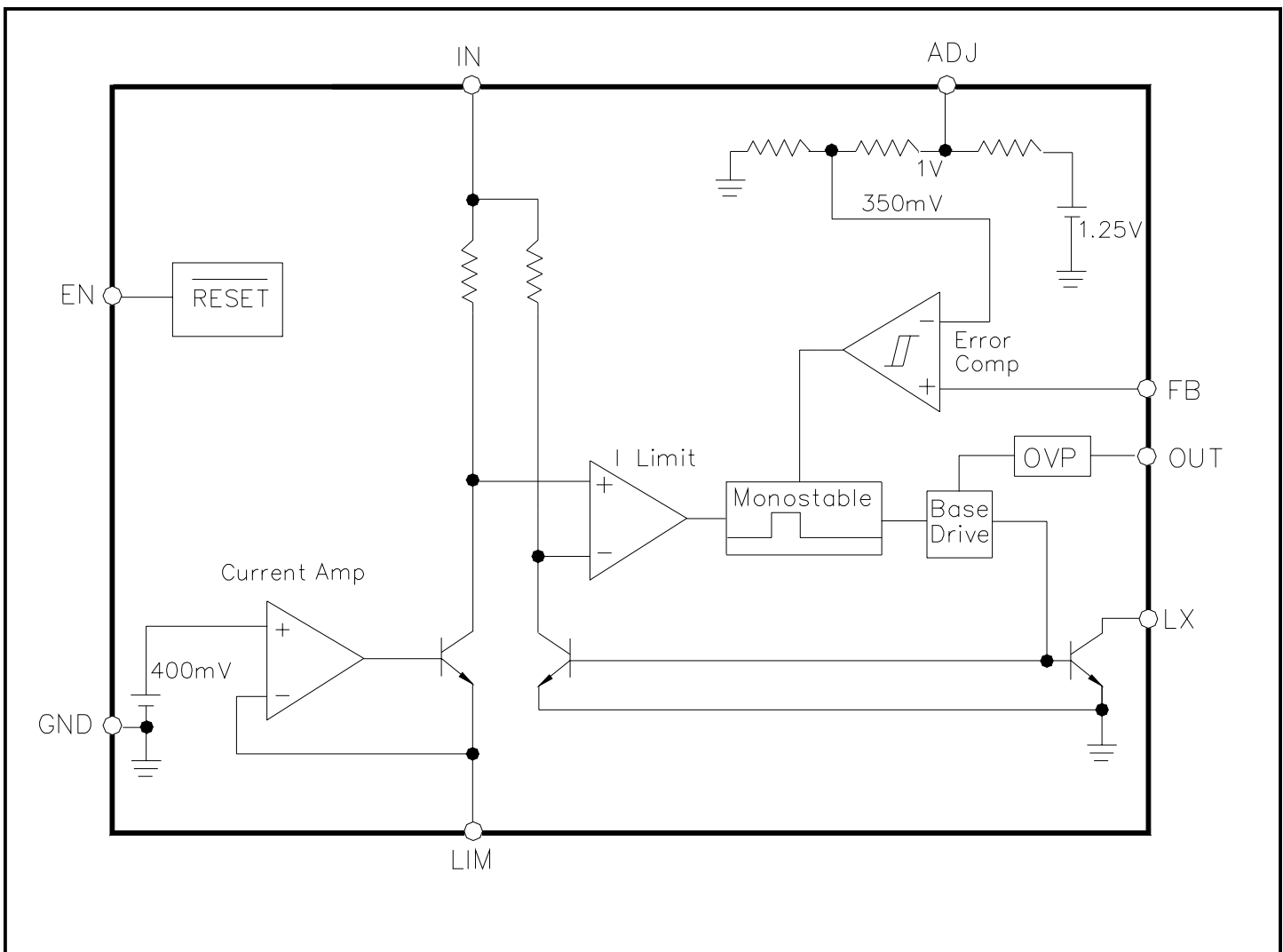

**POWER MANAGEMENT**
**Pin Descriptions**

Pin	Pin Name	Pin Function
1	ADJ	Apply a PWM or analog voltage to this pin for dynamic output current adjustment.
2	FB	Connects to the resistor in the ground leg of the series LEDs (feedback for the constant load current).
3	GND	Ground pin.
4	OUT	Connect to the boost output at the cathode of the schottky diode. This pin is the input for the over-voltage protection circuit.
5	LX	Internal switch connection. Connect the inductor and the anode of the schottky diode to this pin.
6	IN	Input supply pin. Connect to a battery or power supply.
7	LIM	Current limit set pin. A resistor ( $R_{LIM}$ ) connected from LIM to GND sets the peak inductor current limit threshold.
8	EN	Digital input for enable. Connect this pin to ground for shutdown or connect a voltage between 1.2V to 5.0V for enable. A $1M\Omega$ pull-up resistor connecting to IN is also acceptable, provided $10\mu A > I_{EN} > 300nA$ .

**Marking Information**

104

yyww

Marking for the MLP 8 Lead package:  
yyww = Date Code (Example: 0012)

**POWER MANAGEMENT**
**Applications Information**
**Component Selection - Introduction**

Referring to the 6 LED typical schematic below, there are three components that depend upon the application that need to be determined:

RSET - this resistor sets the output current for the device

RLIM - this resistor sets the peak inductor current

L - the output inductor

All the other components can be mostly generalized and are addressed below the following design steps.

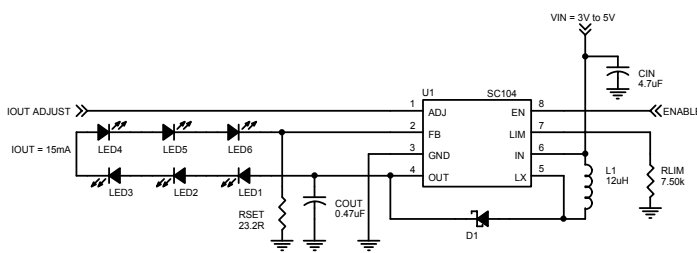
**Step 1: Continuous or Discontinuous?**

The first thing to do when designing with the SC104 is to determine whether the output inductor will be operating in continuous mode (where the inductor current does not drop to zero while the device is switching) or discontinuous mode (where the inductor current drops to zero while switching). This determination can be made simply by calculating the required duty cycle needed for the target output voltage, and comparing it to the guaranteed minimum value for the maximum duty cycle from the Electrical Characteristics on Page 3.  $\%_{DC(MIN)} = 70\%$  (or 0.7 duty). If DC is greater than 0.7 then discontinuous mode is required. The required duty cycle is calculated as follows:

$$DC = \frac{(V_{OUT} - V_{IN} + V_f)}{(V_{OUT} - V_{CE(SAT)} + V_f)}$$

Where:

$V_{OUT}$  = output voltage, the sum of the total LED (max.) forward voltage drop at the required output voltage plus the feedback voltage, 0.35V.

$V_{IN}$  = minimum input voltage

$V_f$  = Schottky diode (D1) forward voltage drop

$V_{CE(SAT)}$  = power switch saturation voltage

Using the 6 LED example above:

$$V_{OUT} = (6 * 3.475) + 0.35 = 21.2V$$

$$V_{IN} = 3V$$

$$V_f = 0.35V$$

$$V_{CE(SAT)} = 0.25V$$

thus  $DC = 0.87$

Since this value is greater than the guaranteed minimum value for maximum duty cycle, the device will be operating in discontinuous mode to provide the desired output. Note that the duty cycle does not depend upon the output current, and that unless the output to input ratio is low, the device will usually need to be in discontinuous mode, so we will cover that first (Step 1 through Step 5). Continuous mode calculations start at Step 6.

**Step 2: Calculating the Inductor for Discontinuous Mode**

Having determined that we need to be operating in discontinuous mode, we next need to calculate the maximum inductor value allowed that will permit the part to output the correct power. The maximum discontinuous inductor value,  $L_{(D)}$  is given by:

$$L_{(D)} = \frac{t_{ON(MIN)}^2 \cdot V_{IN} \cdot (V_{IN} - V_{CE(SAT)})}{2 \cdot 1.4 \cdot V_{OUT} \cdot I_{OUT} \cdot (t_{ON(MIN)} + t_{OFF(MIN)})} \cdot \frac{(V_{OUT} - V_{CE(SAT)} + V_f)}{(V_{OUT} - V_{IN} + V_f)}$$

Where:

$t_{ON(MIN)}$  = minimum switch on-time = 1.8 $\mu$ s

$I_{OUT}$  = required output current

$t_{OFF(MIN)}$  = minimum switch off-time = 0.6 $\mu$ s

Using our 6 LED example:

$$I_{OUT} = 15mA$$

$$\text{thus } L_{(D)} = 14.4\mu H$$

Selecting the next lower standard value gives us  $L_{(D)} = 12\mu H$ . Of course a lower value inductor may be used if desired, but may not necessarily be the most efficient choice.

**Step 3: Calculating the Current Limit Required with this Inductor for Discontinuous Mode**

Having determined the inductor value we are going to use, we next need to calculate the current limit required to meet the necessary output power. The discontinuous mode current limit,  $I_{LIM(D)}$ , is given by:

$$I_{LIM(D)} = \frac{(V_{IN} - V_{CE(SAT)}) \cdot t_{ON(MIN)}}{L_{(D)}}$$

**POWER MANAGEMENT**
**Applications Information (Cont.)**
**Step 3: (Cont.)**

Using our 6 LED example:

$$L_{(D)} = 12\mu\text{H}$$

$$\text{thus } I_{LIM(D)} = 412\text{mA}$$

**Step 4: Calculating the Current Limit Resistor for Discontinuous Mode**

The current limit resistor value is calculated based upon the minimum ratio of the switch current to the current out of the LIM pin. It also takes into account the fact that there is a propagation delay during which time the inductor current ramps beyond the current limit trip point. Since  $I_{LIM}$  increases as  $R_{LIM}$  decreases, this value is a maximum. The maximum current limit resistor,  $R_{LIM(D)}$ , for discontinuous mode is therefore:

$$R_{LIM(D)} = \frac{V_{LIM(MIN)} \cdot \text{Ratio}_{(MIN)}}{\left( I_{LIM(D)} - \frac{t_{plh} \cdot (V_{IN} - V_{CE(SAT)})}{L_{(D)}} \right)}$$

Where:

$V_{LIM(MIN)}$  = the minimum value of the current limit voltage reference = 385mV

$\text{Ratio}_{(MIN)}$  = the minimum value of the  $I_{LX}$  to  $I_{LIM}$  ratio = 7100 A/A

$t_{plh}$  = propagation delay from reaching the current limit trip point to the power switch turning off = 200ns

Using our 6 LED example:

$$I_{LIM(D)} = 412\text{mA}$$

$$\text{thus } R_{LIM(D)} = 7.5\text{k}\Omega$$

Selecting this value or the next lower standard value in this case gives us 7.5k $\Omega$ . Of course a lower value resistor may be used if desired, but may not necessarily be the most efficient choice.

**Step 5: Calculating the Current Set Resistor**

The current set resistor is in series with the series LED string. Thus the voltage developed across it is proportional to the current flowing through the LEDs. The device will regulate this voltage so that its average value equals the feedback voltage,  $V_{FB}$ , which is typically 350mV. Thus the current set resistor value is given by the following

equation:

$$R_{SET} = \frac{V_{FB}}{I_{OUT}}$$

Using our 6 LED example:

$$I_{OUT} = 15\text{mA}$$

$$\text{thus } R_{SET} = 23.3\Omega$$

We will select the 1% resistor value 23.2 $\Omega$ .

Note: this calculation is applicable to both continuous and discontinuous modes.

**Step 6: Calculating the Inductor for Continuous Mode**

Having determined that we need to be operating in continuous mode, we next need to calculate the maximum inductor value allowed that will permit the part to output the correct power. The maximum continuous inductor value,  $L_{(C)}$  is given by:

$$L_{(C)} = \frac{2 \cdot V_{IN} \cdot t_{OFF(MIN)} \cdot (V_{OUT} + V_f - V_{IN})}{1.4 \cdot V_{OUT} \cdot I_{OUT}}$$

Where:

$I_{OUT}$  = required output current

$t_{OFF(MIN)}$  = minimum switch off-time = 0.6 $\mu\text{s}$

Selecting the next lower standard value gives us a safe value for this inductor.

**Step 7: Calculating the Current Limit Required with this Inductor for Continuous Mode**

Having determined the inductor value we are going to use, we next need to calculate the current limit required to meet the necessary output power. The continuous mode current limit,  $I_{LIM(C)}$ , is given by:

$$I_{LIM(C)} = \frac{(V_{OUT} + V_f - V_{IN}) \cdot t_{OFF(MIN)}}{0.4 \cdot L_{(C)}}$$

**Step 8: Calculating the Current Limit Resistor for Continuous Mode**

The current limit resistor value is calculated based upon the minimum ratio of the switch current to the current out of the LIM pin. It also takes into account the fact that there is a propagation delay during which time the



**POWER MANAGEMENT**
**Applications Information (Cont.)**
**Step 8: (Cont.)**

inductor current ramps beyond the current limit trip point. Since  $I_{LIM}$  increases as  $R_{LIM}$  decreases, this value is a maximum. The maximum current limit resistor,  $R_{LIM(C)}$ , for continuous mode is therefore:

$$R_{LIM(C)} = \frac{V_{LIM(MIN)} \cdot \text{Ratio}_{(MIN)}}{\left( I_{LIM(C)} - \frac{t_{plh} \cdot (V_{IN} - V_{CE(SAT)})}{L_{(C)}} \right)}$$

Where:

$V_{LIM(MIN)}$  = the minimum value of the current limit voltage reference = 385mV

$\text{Ratio}_{(MIN)}$  = the minimum value of the  $I_{LX}$  to  $I_{LIM}$  ratio = 7100 A/A

$t_{plh}$  = propagation delay from reaching the current limit trip point to the power switch turning off = 200ns

Selecting the calculated value or the next lower standard value is recommended.

**Component Selection - General**

Capacitor Selection: the SC104 has been designed to be used with ceramic input and output capacitors. The input to the device should be bypassed using a 4.7µF ceramic capacitor rated for the maximum input voltage. The output capacitor should be a ceramic capacitor in the range of 0.22µF to 1µF. Care should be taken that the voltage rating of this capacitor meets the output voltage requirements, and if the part is going to be run open circuit during assembly testing using the OVP feature, then the capacitor should be rated 50V.

Schottky diode: any schottky diode rated for the average and peak currents being seen in the circuit will suffice. However a higher current rated schottky diode will result in lower forward voltage drops and hence higher efficiency. The selection of the schottky will depend upon the optimum choice between efficiency, board space, and cost.

Inductor: similarly, any inductor rated for the average and peak currents required by the design and capable of operating at the fixed off-time of 760ns will suffice, but inductors with lower series resistance will result in lower losses. The selection of the inductor will depend upon the optimum choice between efficiency, board space, component height, and cost. Toko D62LCB and D63LCB series work very well.

**LED Dimming**

Dimming the LEDs (i.e. reducing the output current from the set level to reduce brightness) can be achieved a couple of ways:

- 1) PWMing the ADJ pin using an open drain or open collector (with no pull-up). Using a PWM signal at this pin will reduce the output current by alternating between OFF (ADJ < 100mV) and switching normally. The lower the duty cycle, the lower the output current. A PWM frequency of 1kHz maximum is recommended.
- 2) analog voltage applied to the ADJ pin: apply a DC voltage between 0V to 0.1V (OFF) and 1V (full current) to the ADJ pin. This pin should not be pulled above 1V under normal operation, and should never exceed the absolute maximum rating. Using a DC voltage will result in the modulation frequency of the inductor current ramp reducing and care must be taken to ensure that this does not become audible in sensitive applications.

**POWER MANAGEMENT**

**Typical Characteristics**

**Shutdown Current vs. Junction Temperature vs. Input Voltage**

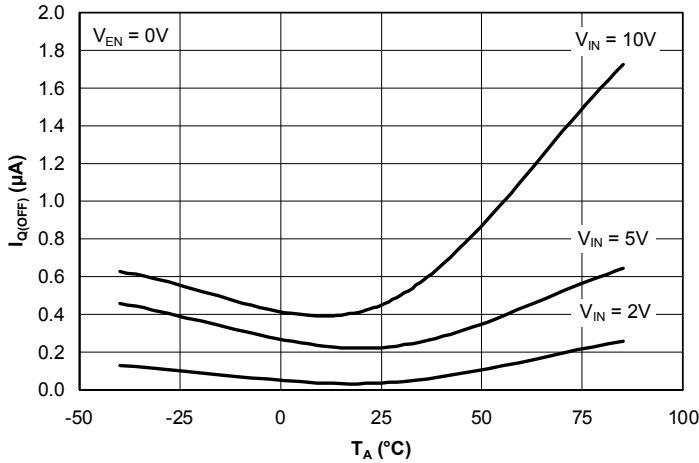

**Average Feedback Voltage vs. Junction Temperature vs. Input Voltage**

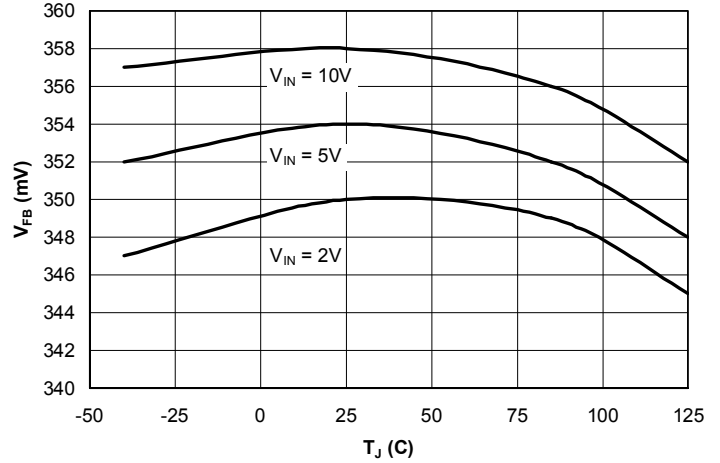

**Power Switch Saturation Voltage vs. Junction Temperature**

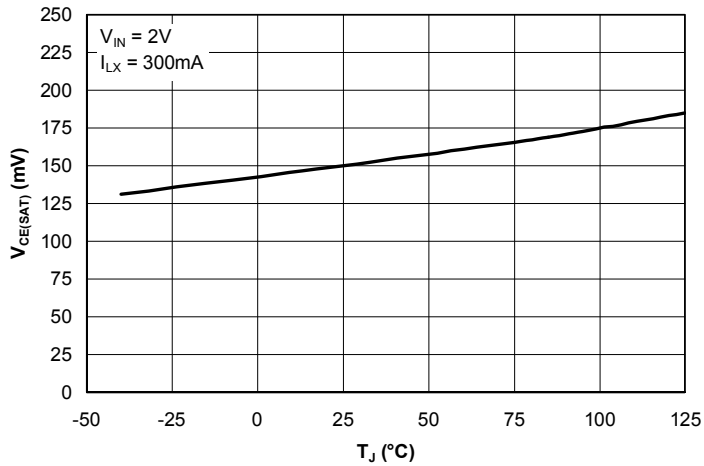

**Current Limit Reference Voltage vs. Junction Temperature**

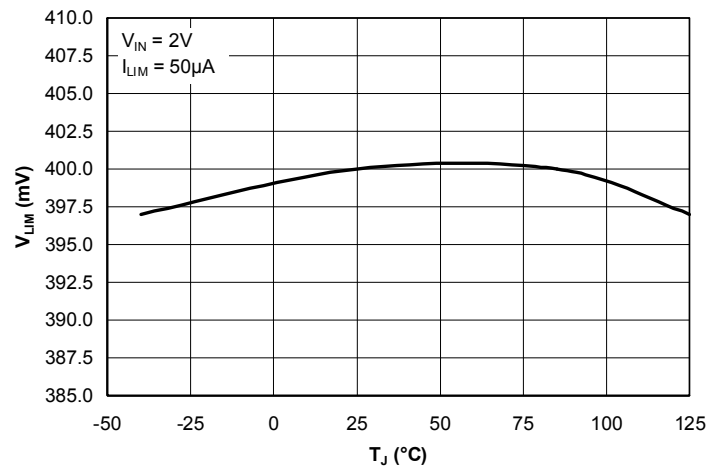

**I<sub>LX</sub> to I<sub>LIM</sub> Ratio vs. Junction Temperature**

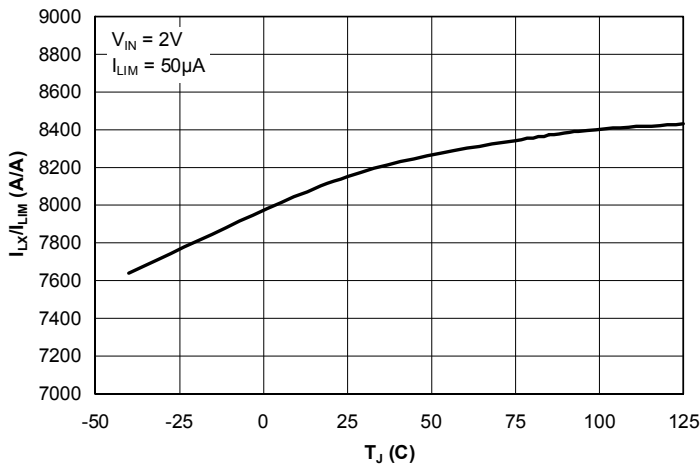

POWER MANAGEMENT

Typical Application Circuit - 3 LEDs

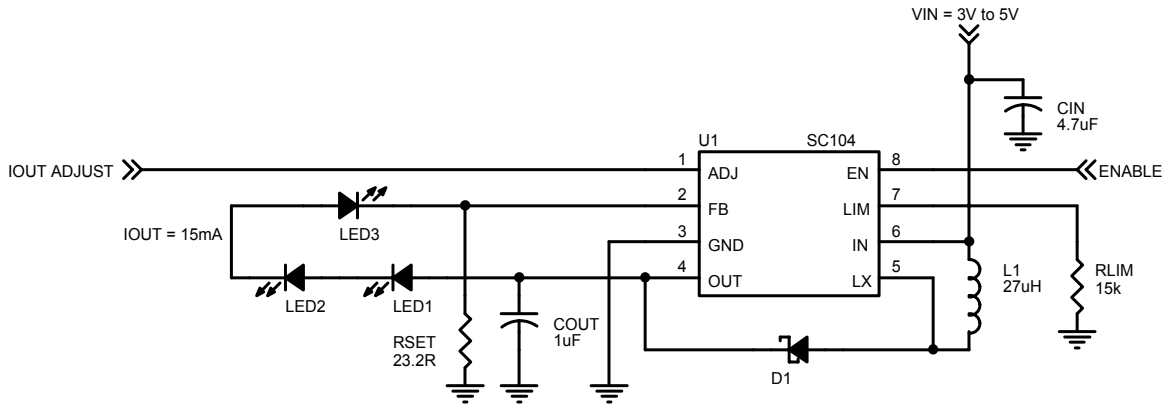

Typical Application Circuit - 10 LEDs

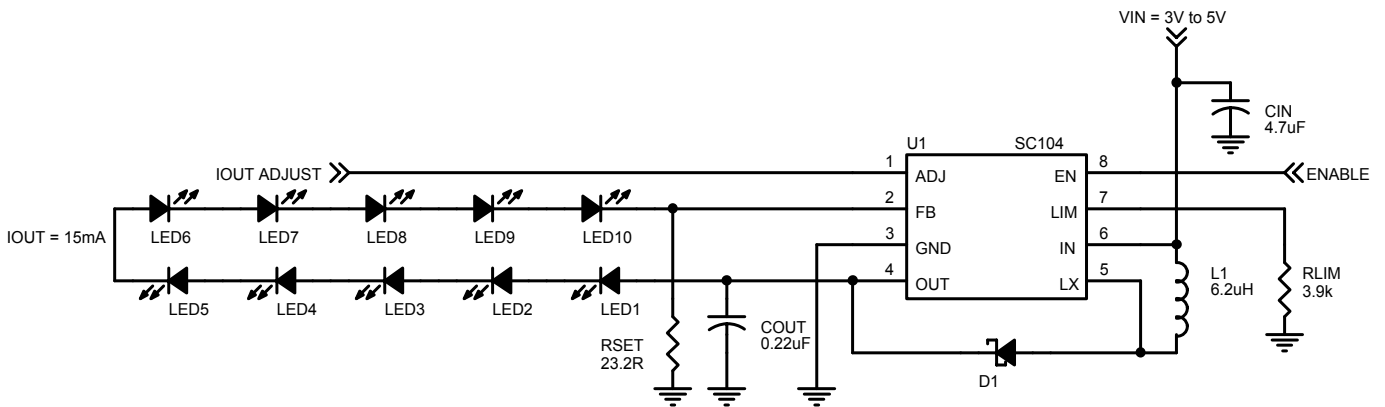

POWER MANAGEMENT

Outline Drawing - MLP-8

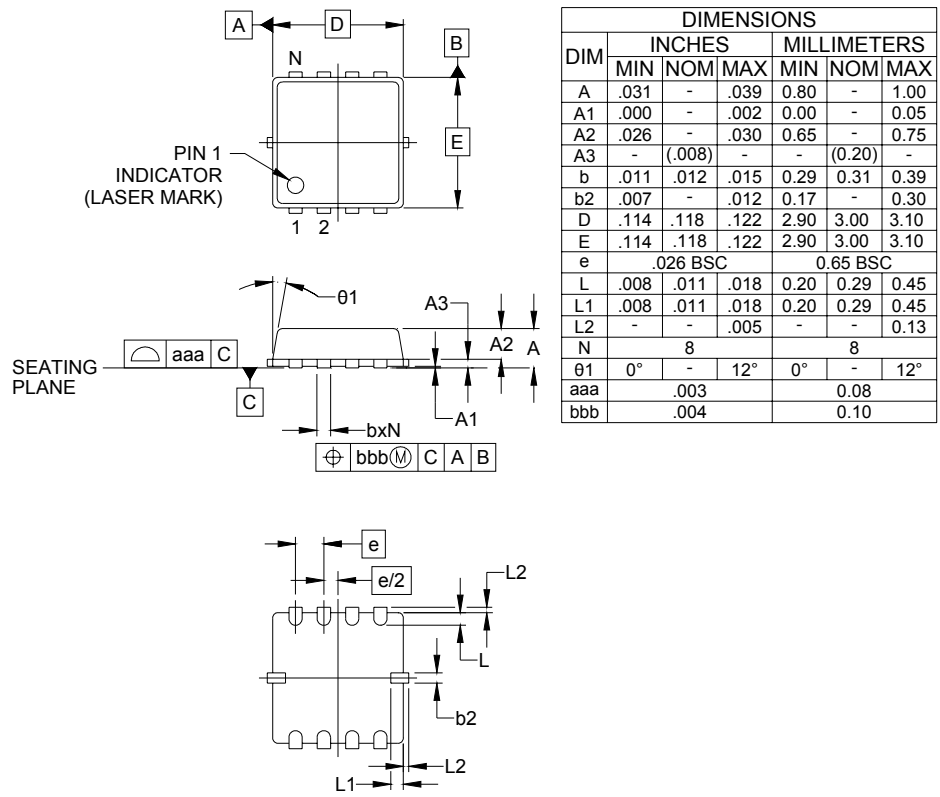

DIM	INCHES			MILLIMETERS		
	MIN	NOM	MAX	MIN	NOM	MAX
A	.031	-	.039	0.80	-	1.00
A1	.000	-	.002	0.00	-	0.05
A2	.026	-	.030	0.65	-	0.75
A3	-	(.008)	-	-	(0.20)	-
b	.011	.012	.015	0.29	0.31	0.39
b2	.007	-	.012	0.17	-	0.30
D	.114	.118	.122	2.90	3.00	3.10
E	.114	.118	.122	2.90	3.00	3.10
e	.026 BSC			0.65 BSC		
L	.008	.011	.018	0.20	0.29	0.45
L1	.008	.011	.018	0.20	0.29	0.45
L2	-	-	.005	-	-	0.13
N	8			8		
$\theta 1$	0°	-	12°	0°	-	12°
aaa	.003			0.08		
bbb	.004			0.10		

- NOTES:
1. CONTROLLING DIMENSIONS ARE IN MILLIMETERS (ANGLES IN DEGREES).
  2. DIMENSIONS "D" AND "E" DO NOT INCLUDE MOLD FLASH, PROTRUSIONS OR GATE BURRS.

**POWER MANAGEMENT**

**Land Pattern - MLP-8**

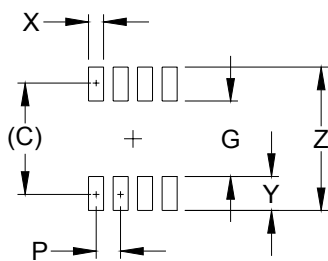

DIMENSIONS		
DIM	INCHES	MILLIMETERS
C	(.114)	(2.90)
G	.079	2.00
P	.026	0.65
X	.015	0.38
Y	.035	0.90
Z	.150	3.80

NOTES:

1. THIS LAND PATTERN IS FOR REFERENCE PURPOSES ONLY. CONSULT YOUR MANUFACTURING GROUP TO ENSURE YOUR COMPANY'S MANUFACTURING GUIDELINES ARE MET.

**Contact Information**

Semtech Corporation  
 Power Management Products Division  
 200 Flynn Road, Camarillo, CA 93012  
 Phone: (805) 498-2111 FAX (805)498-3804

Visit us at: [www.semtech.com](http://www.semtech.com)