



Chipsmall Limited consists of a professional team with an average of over 10 year of expertise in the distribution of electronic components. Based in Hongkong, we have already established firm and mutual-benefit business relationships with customers from,Europe,America and south Asia,supplying obsolete and hard-to-find components to meet their specific needs.

With the principle of “Quality Parts,Customers Priority,Honest Operation,and Considerate Service”,our business mainly focus on the distribution of electronic components. Line cards we deal with include Microchip,ALPS,ROHM,Xilinx,Pulse,ON,Everlight and Freescale. Main products comprise IC,Modules,Potentiometer,IC Socket,Relay,Connector.Our parts cover such applications as commercial,industrial, and automotives areas.

We are looking forward to setting up business relationship with you and hope to provide you with the best service and solution. Let us make a better world for our industry!



## Contact us

Tel: +86-755-8981 8866 Fax: +86-755-8427 6832

Email & Skype: info@chipsmall.com Web: www.chipsmall.com

Address: A1208, Overseas Decoration Building, #122 Zhenhua RD., Futian, Shenzhen, China



## POWER MANAGEMENT

### Description

The SC1110 is a low-cost, full featured, synchronous voltage-mode controller designed to generate termination voltage in double data rate (DDR) memory systems and other applications where wide data bus need to be actively terminated. Synchronous control of the MOSFET half bridge allows power flowing bi-directionally. The termination voltage can be tightly regulated to track the chipset voltage, i.e. to be exactly 50% of that at all times.

The SC1110 is ideal for low cost implementation of termination voltage supplies. SC1110 features include temperature compensated voltage reference, triangle wave oscillator and current sense comparator circuitry, and allows the use of inexpensive N-channel power MOSFETs.

The SC1110 operates at a fixed 250kHz, providing an optimum compromise between efficiency, transient performance, external component size, and cost.

### Features

- ◆ Generates termination voltages for active termination schemes
- ◆ 1% set point accuracy
- ◆ For  $\pm 7A$  output current, transient regulation is better than  $\pm 80mV$
- ◆  $V_{REFIN}$  pin available for external 50% resistive divider to allow termination voltage track of the chip set voltage
- ◆ Buffered  $V_{REFOUT}$  for system usage
- ◆  $R_{DS(ON)}$  sensing for over current protection in hiccup mode
- ◆ Soft start and logic input enabling
- ◆ 250kHz switching for best transient and efficiency performance
- ◆ Gate drive capable for 0.5A sourcing and sinking

### Applications

- ◆ For DDR memory systems
- ◆ For active termination schemes in high speed logic systems

### Typical Application Circuit

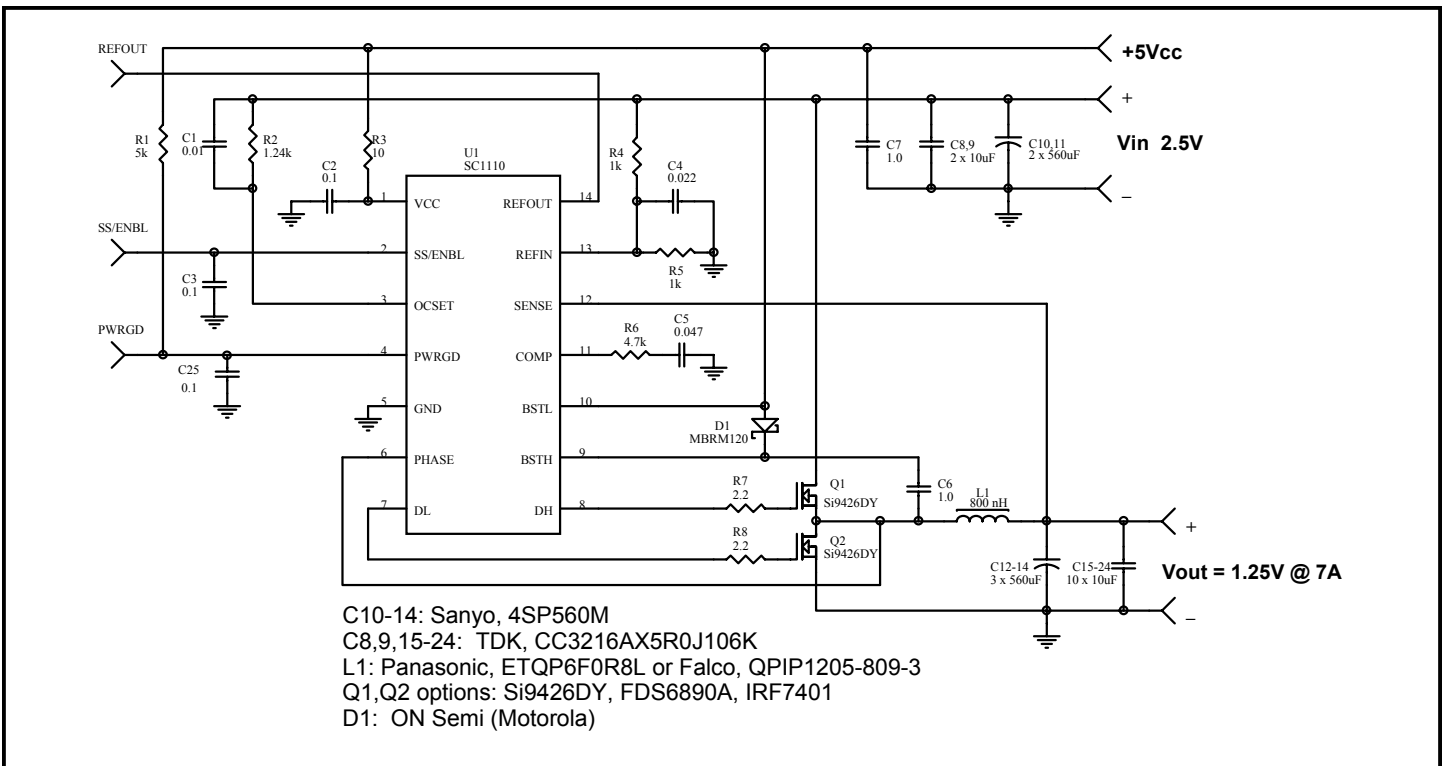

**POWER MANAGEMENT**
**Absolute Maximum Ratings**

Exceeding the specifications below may result in permanent damage to the device, or device malfunction. Operation outside of the parameters specified in the Electrical Characteristics section is not implied.

| Parameter                              | Symbol            | Maximum     | Units |
|--|-------------------|-------------|-------|
| V <sub>CC</sub> , BSTL to GND          | V <sub>IN</sub>   | -0.5 to 14  | V     |
| PGND to GND                            |                   | +0.5        | V     |
| PHASE to GND                           |                   | -0.3 to 18  | V     |
| BSTH to PHASE                          |                   | 14          | V     |
| Thermal Impedance Junction to Case     | θ <sub>JC</sub>   | 45          | °C/W  |
| Thermal Resistance Junction to Ambient | θ <sub>JA</sub>   | 115         | °C/W  |
| Operating Temperature Range            | T <sub>A</sub>    | 0 to 70     | °C    |
| Storage Temperature Range              | T <sub>STG</sub>  | -65 to +150 | °C    |
| Lead Temperature (Soldering) 10 Sec.   | T <sub>LEAD</sub> | 300         | °C    |
| ESD Rating (Human Body Model)          | V <sub>ESD</sub>  | 2           | kV    |

**Electrical Characteristics**

Unless specified: V<sub>CC</sub> = 4.75V to 12.6V; GND = PGND = 0V; FB = V<sub>O</sub>; V<sub>BSTL</sub> = 12V; V<sub>BSTH-PHASE</sub> = 12V; T<sub>J</sub> = 25°C

| Parameter                    | Conditions  | Min | Typ  | Max  | Units |
|------------------------------|---|-----|------|------|-------|
| <b>Power Supply</b>          |   |     |      |      |       |
| Supply Voltage               | V <sub>CC</sub>   | 4.4 |      | 12.6 | V     |
| Supply Current               |   |     | 8    | 12   | mA    |
| Line Regulation              | V <sub>O</sub> = 2.5V ± 0.5V, V <sub>O</sub> = V <sub>N</sub> /2 @ 0A |     | 0.5  |      | %     |
| <b>Under Voltage Lockout</b> |   |     |      |      |       |
| Turn-On Threshold            |   |     | 4.15 |      | V     |
| Turn-Off Threshold           |   |     | 3.95 |      | V     |
| <b>Error Amplifier</b>       |   |     |      |      |       |
| Transconductance             |   |     | 2    |      | mS    |
| Open Loop DC Gain            |   |     | 50   |      | dB    |
| Bandwidth - 3dB              | (Unity gain crossover 70MHz)  |     | 500  |      | kHz   |
| COMP Source Capability       |   |     | ±250 |      | µA    |
| Input Bias                   |   |     | 2    | 5    | µA    |
| <b>Oscillator</b>            |   |     |      |      |       |
| Oscillator Frequency         |   | 225 | 250  | 275  | kHz   |
| Oscillator Max Duty Cycle    |   | 90  | 95   |      | %     |
| Ramp Height                  |   |     | 1    |      | V     |

**POWER MANAGEMENT**
**Electrical Characteristics (Cont.)**

 Unless specified:  $V_{CC} = 4.75V$  to  $12.6V$ ;  $GND = PGND = 0V$ ;  $FB = V_O$ ;  $V_{BSTL} = 12V$ ;  $V_{BSTH-PHASE} = 12V$ ;  $T_J = 25^\circ C$ 

| Parameter                   | Conditions   | Min  | Typ  | Max  | Units   |
|-----------------------------|--|------|------|------|---------|
| <b>Timing</b>               |  |      |      |      |         |
| Minimum Off-Time            |  |      | 200  |      | ns      |
| Dead Time                   | Guaranteed by characterization                           | 80   |      |      | ns      |
| <b>MOSFET Drivers</b>       |  |      |      |      |         |
| Peak DH Sink/Source Current | BSTH - DH = 4.5V, DH - PHASE = 3.0V<br>DH - PHASE = 1.5V | 0.5  |      |      | A       |
|                             |  | 0.1  |      |      |         |
| Peak DL Sink/Source Current | BSTL - DL = 4.5V, DL - GND = 3.0V<br>DL - GND = 1.5V     | 0.5  |      |      | A       |
|                             |  | 0.1  |      |      |         |
| <b>Protection</b>           |  |      |      |      |         |
| Overcurrent Set Isource     | $V_{OCSET} = 2.2V$                                       | 180  | 200  | 220  | $\mu A$ |
| <b>Soft Start</b>           |  |      |      |      |         |
| Charge Current              | $V_{SS} = 1.5V$  | 8    | 10   | 12   | $\mu A$ |
| Discharge Current           | $V_{SS} = 1.5V$  | 1    | 2    | 3    | $\mu A$ |
| <b>Power Good</b>           |  |      |      |      |         |
| Upper Threshold             |  |      | 112  |      | %       |
| Lower Threshold             |  |      | 88   |      | %       |
| PWRGD Voltage Low           | $I_{PWRGD} = 2mA$  |      |      | 0.5  | V       |
| <b>Reference</b>            |  |      |      |      |         |
| REFOUT Source Current       |  |      | 3    |      | mA      |
| Offset                      | $REF_{IN} = 1.25V$                                       | -5   |      | 5    | mV      |
| <b>Enable</b>               |  |      |      |      |         |
| Threshold                   |  | 0.55 | 0.60 | 0.65 | V       |

**POWER MANAGEMENT**

**Timing Diagrams**

**SIMULATION WAVEFORMS**

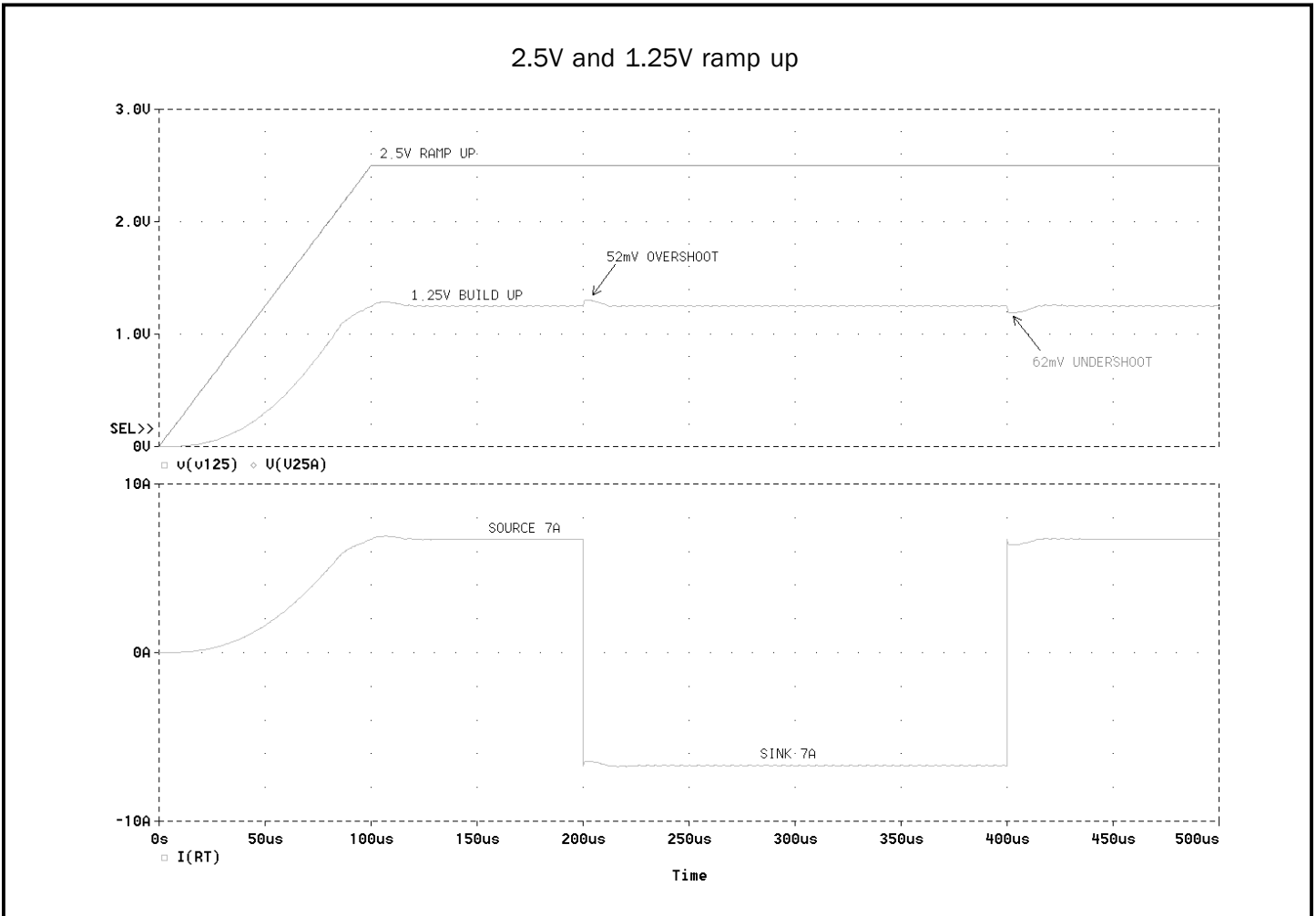

Output current of the VTT supply

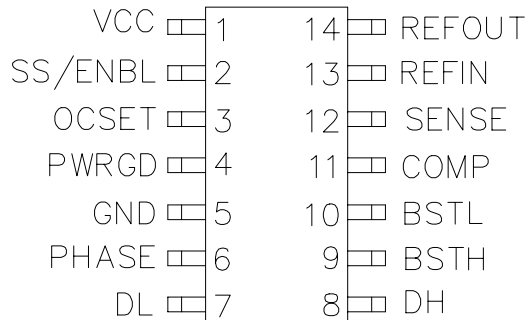
**POWER MANAGEMENT**
**Pin Configuration**

(14 Pin SOIC or TSSOP)

**Ordering Information**

| Device <sup>(1)</sup> | Package <sup>(1)(2)</sup> | Temp Range (T <sub>J</sub> ) |
|-----------------------|---------------------------|------------------------------|
| SC1110CSTRT           | SO-14                     | 0° to 125°C                  |
| SC1110TSTRT           | TSSOP-14                  |                              |

**Notes:**

(1) Only available in tape and reel packaging. A reel contains 2500 devices.

(2) Lead free product.

**Pin Descriptions**

| Pin # | Pin Name | Pin Function                           |
|-------|----------|--|
| 1     | VCC      | Chip Supply Voltage.                   |
| 2     | SS/ENBL  | Soft start/Enable.                     |
| 3     | OCSET    | Current limit set point.               |
| 4     | PWRGD    | Logic high indicates correct output.   |
| 5     | GND      | Ground.                                |
| 6     | PHASE    | Phase node connection between MOSFETs. |
| 7     | DL       | Low side driver output.                |
| 8     | DH       | High side driver output.               |
| 9     | BSTH     | High side driver supply.               |
| 10    | BSTL     | Low side driver supply.                |
| 11    | COMP     | Error amplifier output, compensation.  |
| 12    | SENSE    | Error amplifier negative input.        |
| 13    | REFIN    | Error amplifier positive input.        |
| 14    | REFOUT   | Buffered reference voltage.            |

**NOTE:**

(1) All logic level inputs and outputs are open collector TTL compatible.

**POWER MANAGEMENT**

**Block Diagram**

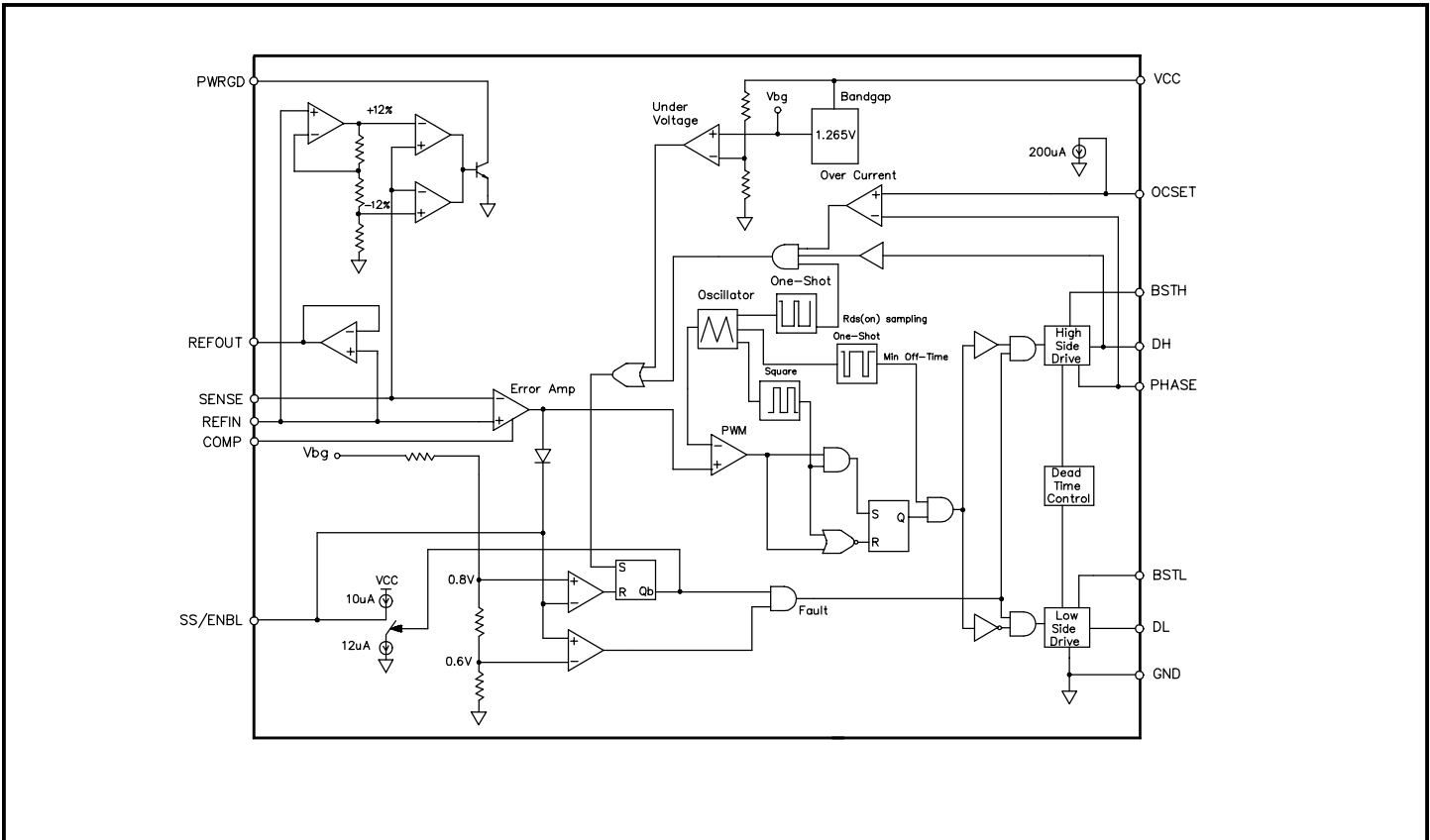

**Applications Information**

**THEORY OF OPERATION**

**Synchronous Buck Converter**

$V_{\text{TERMINATION}}$  power is provided by a synchronous, voltage-mode pulse width modulated (PWM) controller. This section has all the features required to build a high efficiency synchronous buck converter for termination of power application.

The output voltage of the synchronous converter is set and controlled by the output of the error amplifier. The external resistive divider generates reference voltage for the error amplifier from the chipset voltage which is usually 2.5V. The inverting input of the error amplifier receives its voltage from the SENSE pin.

The internal oscillator uses an on-chip capacitor and trimmed precision current sources to set the oscillation frequency to 250kHz. The triangular output of the oscillator sets the reference voltage at the inverting input of the PWM comparator. The non-inverting input of the comparator receives it's input voltage from the error ampli-

fier. When the oscillator output voltage drops below the error amplifier output voltage, the comparator output goes high. This pulls DL low, turning off the low-side FET, and DH is pulled high, turning on the high-side FET (once the cross-current control allows it). When the oscillator voltage rises back above the error amplifier output voltage, the comparator output goes low. This pulls DH low, turning off the high-side FET, and DL is pulled high, turning on the low-side FET (once the cross-current control allows it).

As SENSE increases, the output voltage of the error amplifier decreases. This causes a reduction in the on-time of the high-side MOSFET connected to DH, hence lowering the output voltage.

**Under Voltage Lockout**

The under voltage lockout circuit of the SC1110 assures that both the high-side MOSFET driver outputs remain in the off state whenever the supply voltage drops below set parameters. Lockout occurs if  $V_{\text{CC}}$  falls below 4.1V. Normal operation resumes once  $V_{\text{CC}}$  rises above 4.2V.

**POWER MANAGEMENT****Applications Information****Soft Start**

Initially, SS/ENABLE sources 10 $\mu$ A of current to charge an external capacitor. The outputs of the error amplifiers are clamped to a voltage proportional to the voltage on SS/ENABLE. This limits the on-time of the high-side MOSFETs, thus leading to a controlled ramp-up of the output voltages.

**R<sub>DS(ON)</sub> Current Limiting**

The current limit threshold is set by connecting an external resistor from the V<sub>CC</sub> supply to OCSET. The voltage drop across this resistor is due to the 200 $\mu$ A internal sink sets the voltage at the pin. This voltage is compared to the voltage at the PHASE node. This comparison is made only when the high-side drive is high to avoid false current limit triggering due to uncontributing measurements from the MOSFET's off-voltage. When the voltage at PHASE is less than the voltage at OCSET, an overcurrent condition occurs and the soft start cycle is initiated. The

synchronous switcher turns off and SS/ENABLE starts to sink 2 $\mu$ A. When SS/ENABLE reaches 0.8V, it then starts to source 10 $\mu$ A and a new cycle begins.

**Hiccup Mode**

During power up, the SS/ENABLE pin is internally pulled low until V<sub>CC</sub> reaches the undervoltage lockout level of 4.2V. Once V<sub>CC</sub> has reached 4.2V, the SS/ENABLE pin is released and begins to source 10 $\mu$ A of current to the external soft-start capacitor. As the soft-start voltage rises, the output of the internal error amplifier is clamped to this voltage. When the error signal reaches the level of the internal triangular oscillator, which swings from 1V to 2V at a fixed frequency of 250 kHz, switching occurs. As the error signal crosses over the oscillator signal, the duty cycle of the PWM signal continues to increase until the output comes into regulation. If an over-current condition has not occurred the soft-start voltage will continue to rise and level off at about 2.2V.



**POWER MANAGEMENT**

**Typical Characteristics**

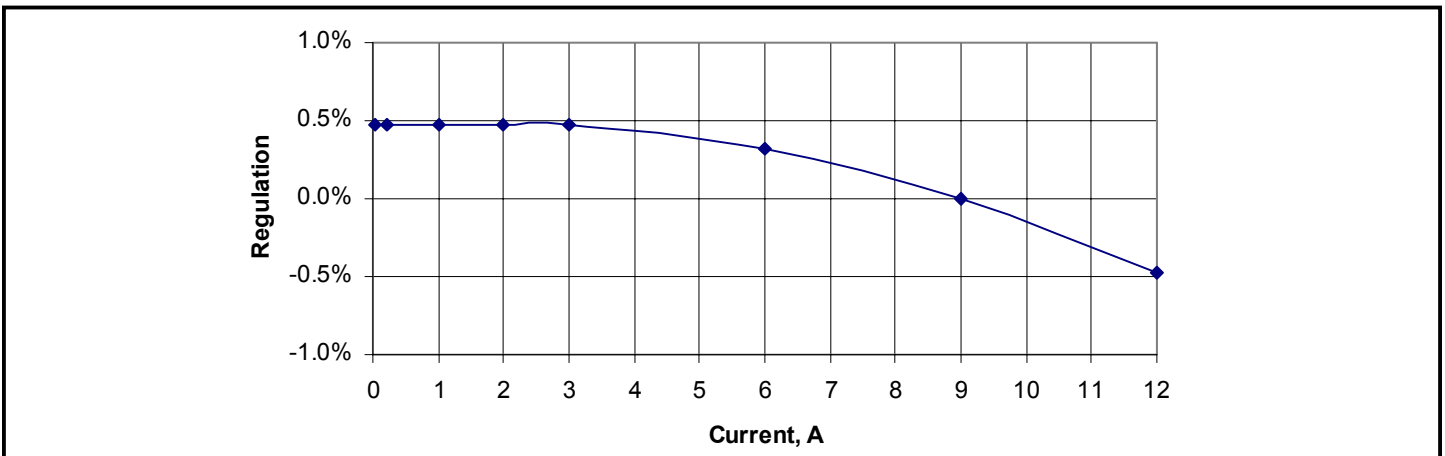
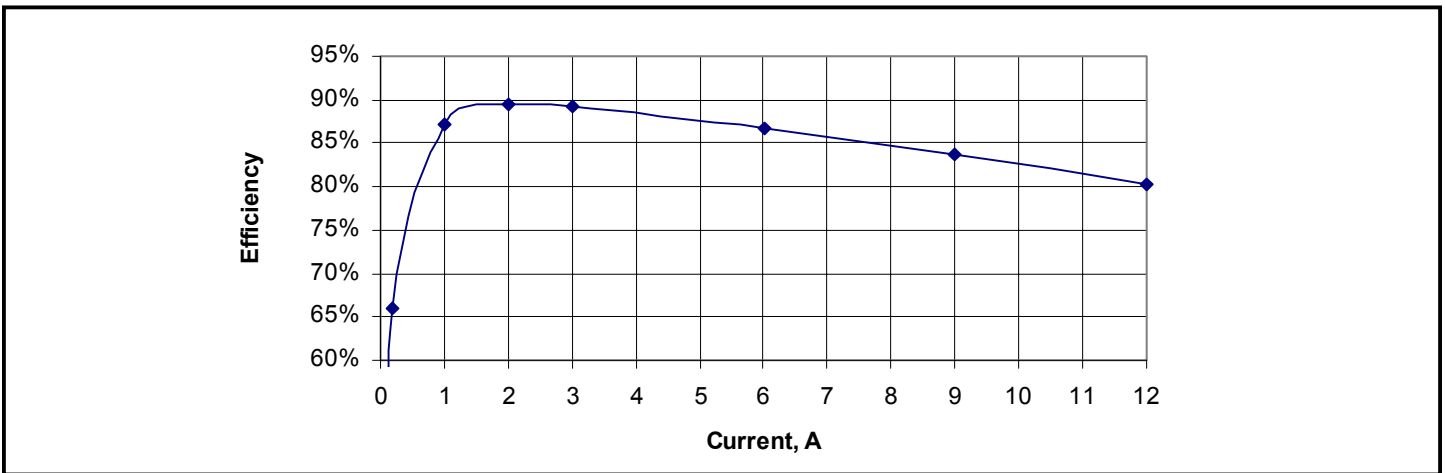
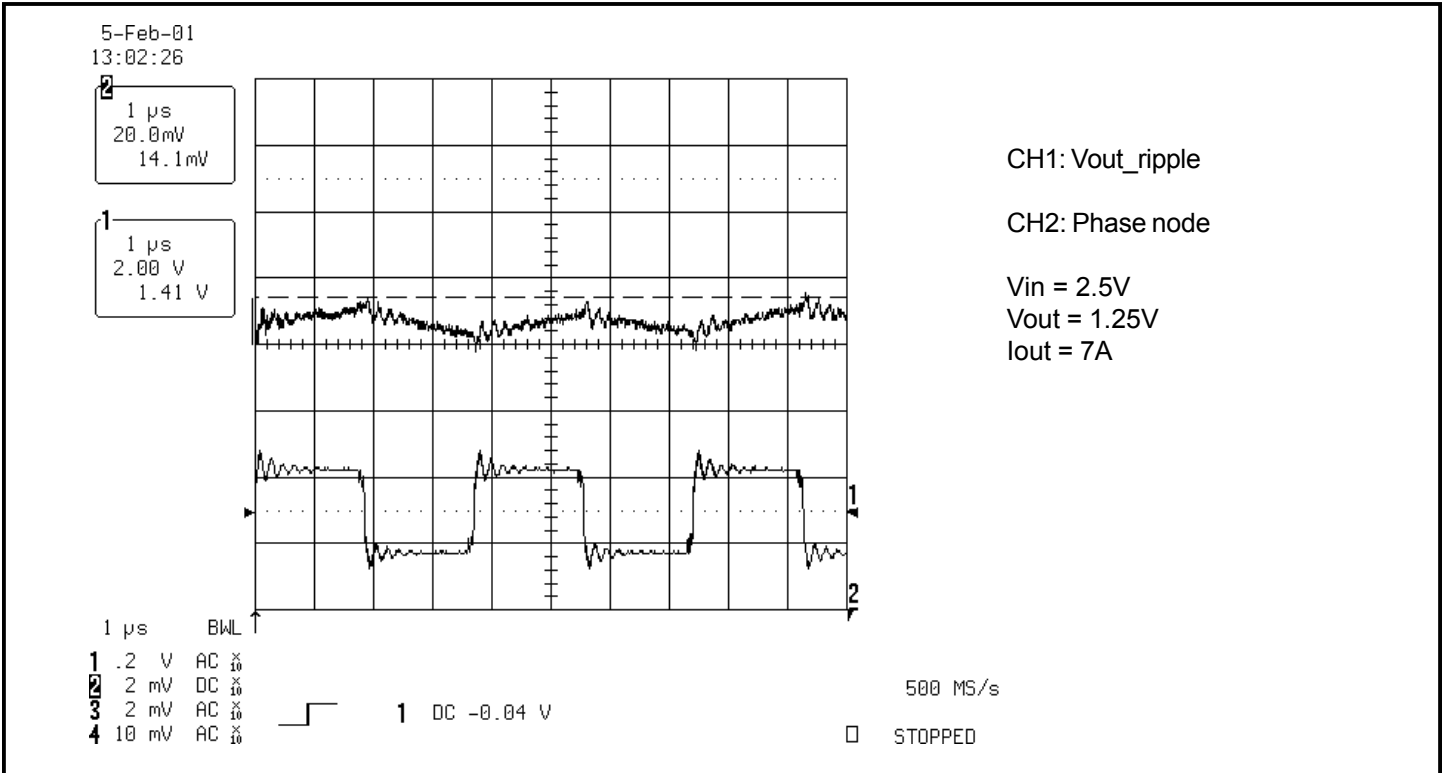

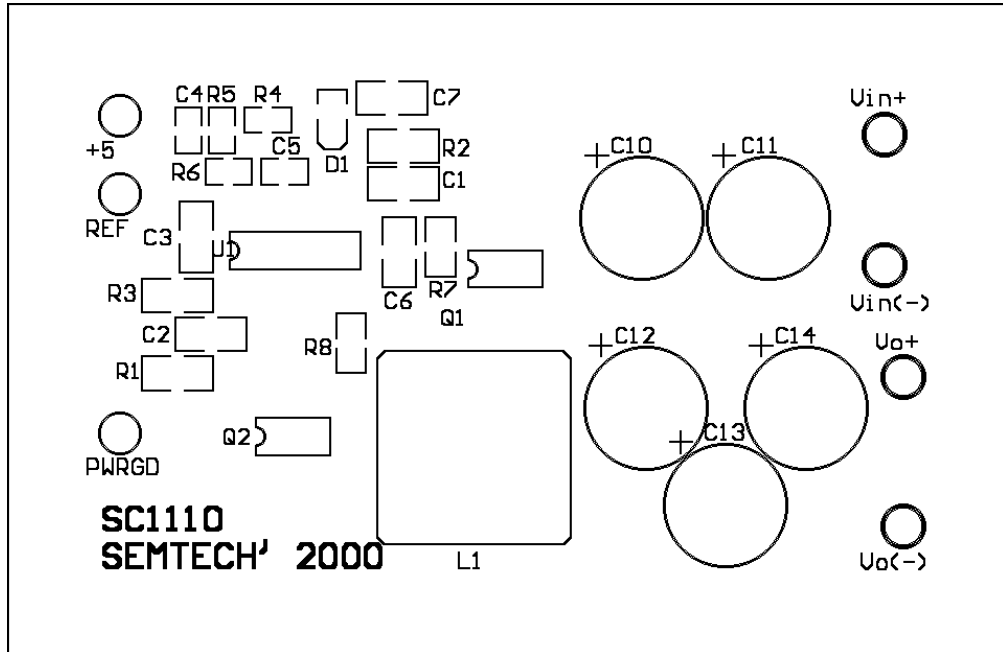
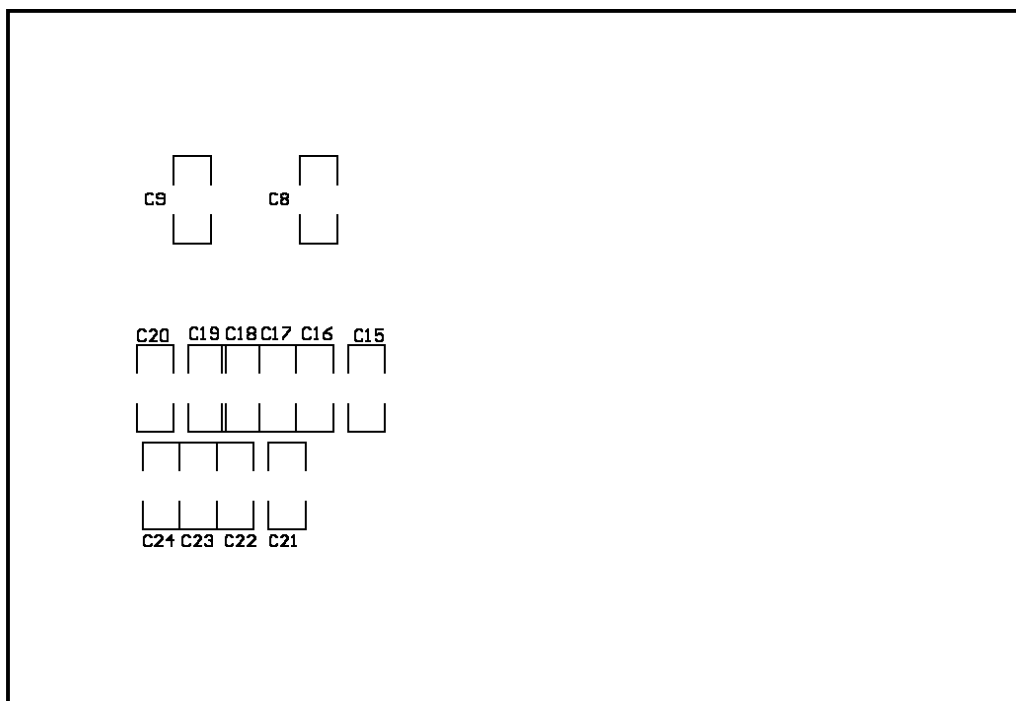
**Top View**

**Bottom View**

**POWER MANAGEMENT**

**Evaluation Board (Cont.)**

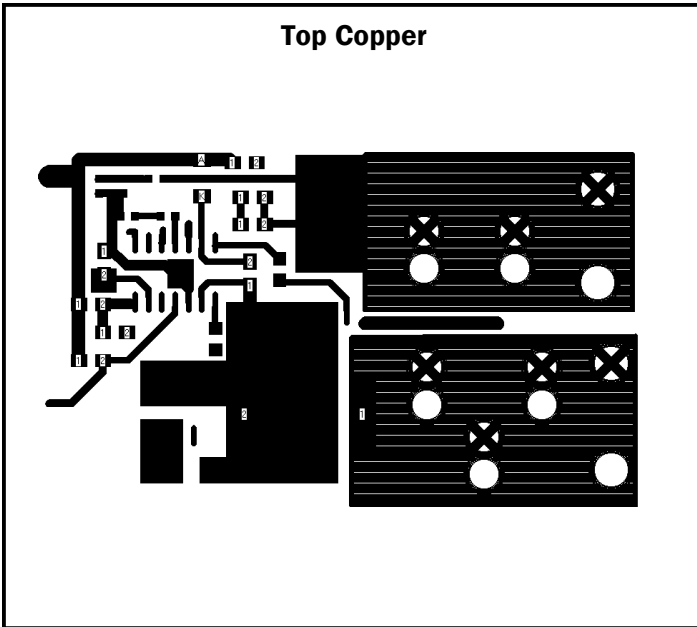
**Top Copper**



**Bottom Copper**

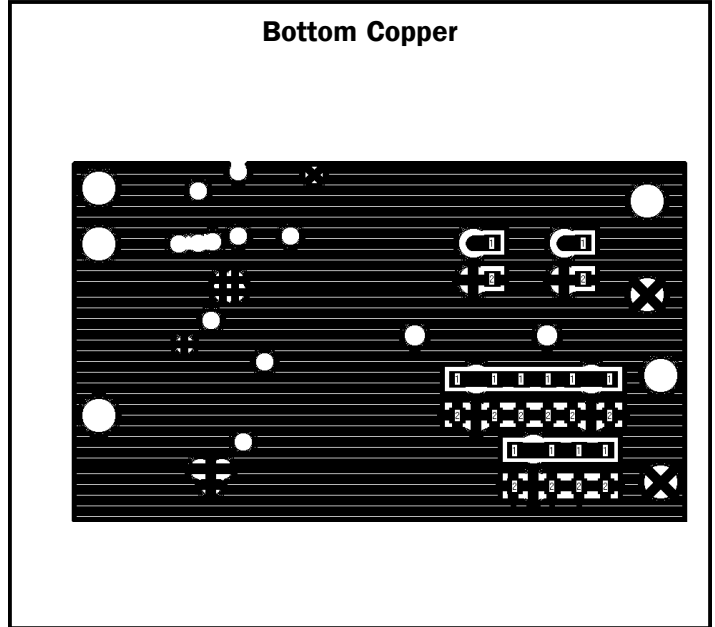

**Midlayer 1**

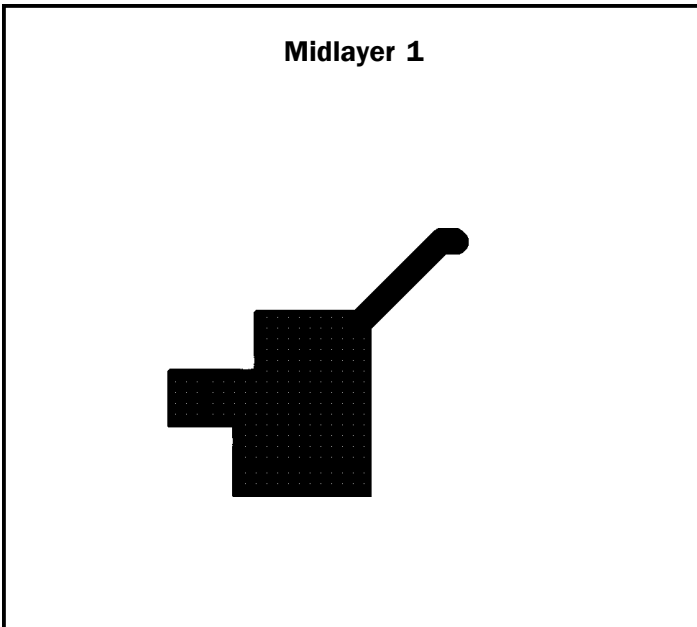

**Midlayer 2**

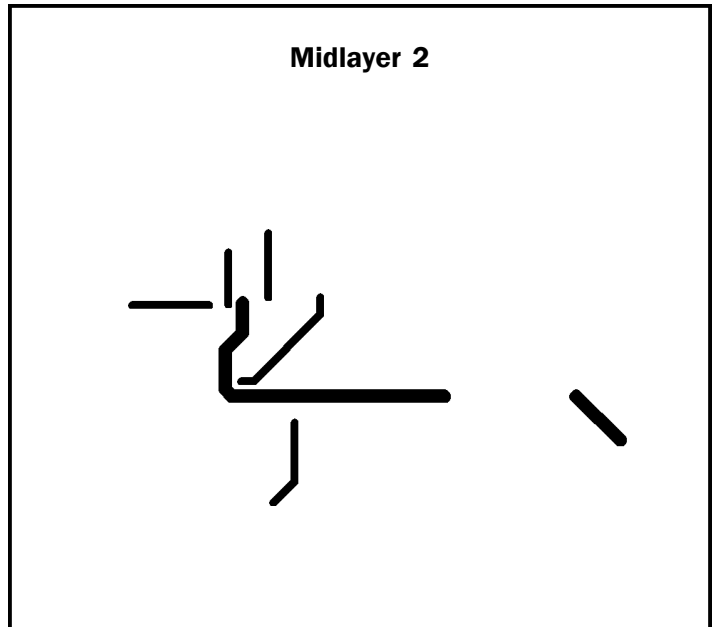

**POWER MANAGEMENT**

**Outline Drawing - SO-14**

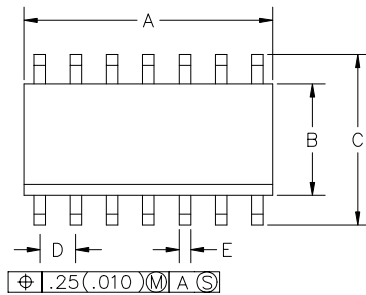

| DIM <sup>N</sup> | INCHES |      | MM   |      | NOTE |
|------------------|--------|------|------|------|------|
|                  | MIN    | MAX  | MIN  | MAX  |      |
| A                | .337   | .344 | 8.55 | 8.75 | 2    |
| B                | .150   | .158 | 3.80 | 4.00 | 3    |
| C                | .228   | .244 | 5.80 | 6.20 |      |
| D                | .050   | BSC  | 1.27 | BSC  |      |
| E                | .013   | .020 | 0.33 | 0.51 |      |
| F                | .004   | .010 | 0.10 | 0.25 |      |
| H                | .053   | .069 | 1.35 | 1.75 |      |
| J                | .010   | .020 | 0.25 | 0.50 |      |
| K                | .007   | .010 | .19  | .25  |      |
| M                | .016   | .050 | 0.40 | 1.27 |      |

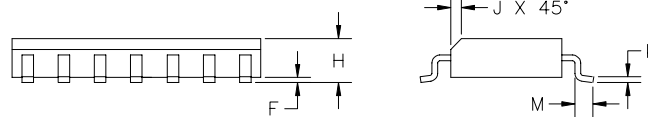

- ③ DIMENSION "B" DOES NOT INCLUDE INTER-LEAD FLASH OR PROTRUSIONS. INTER-LEAD FLASH AND PROTRUSIONS SHALL NOT EXCEED .25 mm (.010") PER SIDE.
- ④ DIMENSION "A" DOES NOT INCLUDE MOLD FLASH, PROTRUSIONS OR GATE BURRS. MOLD FLASH, PROTRUSIONS AND GATE BURRS SHALL NOT EXCEED .15 mm (.010") PER SIDE.
- ① CONTROLLING DIMENSION : MILLIMETER

**Land Pattern - SO-14**

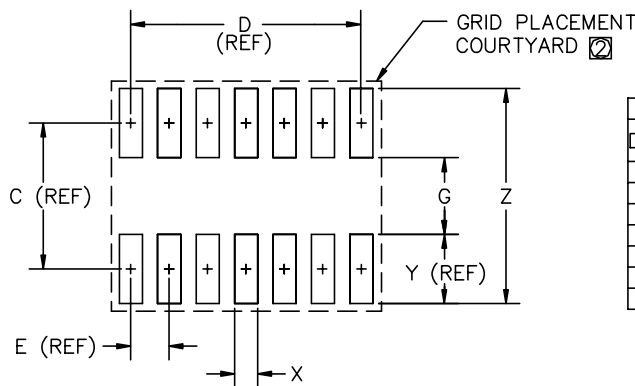

| DIM <sup>N</sup> | INCHES |     | MM   |      | NOTE |
|------------------|--------|-----|------|------|------|
|                  | MIN    | MAX | MIN  | MAX  |      |
| C                | -      | .19 | -    | 5.00 | -    |
| D                | -      | .30 | -    | 7.62 | -    |
| E                | -      | .05 | -    | 1.27 | -    |
| G                | .10    | .11 | 2.60 | 2.80 | -    |
| X                | .02    | .03 | .60  | .80  | -    |
| Y                | -      | .09 | -    | 2.40 | -    |
| Z                | -      | .29 | 7.20 | 7.40 | -    |

- ② GRID PLACEMENT COURTYARD IS 20x16 ELEMENTS (10mm X 8mm) IN ACCORDANCE WITH THE INTERNATIONAL GRID DETAILED IN IEC PUBLICATION 97.
- ① CONTROLLING DIMENSION: MILLIMETERS

**POWER MANAGEMENT**

**Outline Drawing - TSSOP-14**

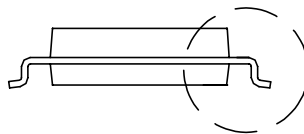
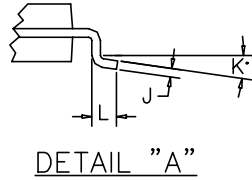
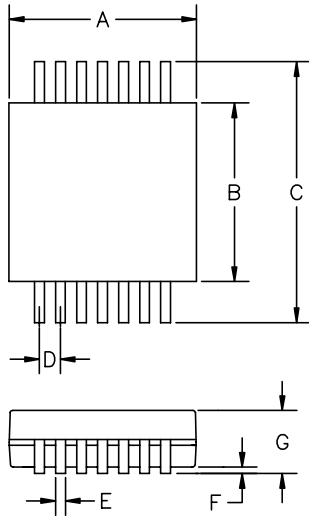

SEE DETAIL A

| DIM <sup>N</sup> | INCHES   |      | MM       |      | NOTE |
|------------------|----------|------|----------|------|------|
|                  | MIN      | MAX  | MIN      | MAX  |      |
| A                | .193     | .201 | 4.90     | 5.10 | ②    |
| B                | .169     | .177 | 4.30     | 4.50 | ②    |
| C                | .252 BSC |      | 6.40 BSC |      | —    |
| D                | .026 BSC |      | .65 BSC  |      | —    |
| E                | .007     | .012 | .19      | .30  | —    |
| F                | .002     | .006 | .05      | .15  | —    |
| G                | .047     |      | 1.20     |      | —    |
| J                | .004     | .008 | .09      | .20  | —    |
| K                | 0°       | 8°   | 0°       | 8°   | —    |
| L                | .018     | .030 | .45      | .75  | —    |

JEDEC MO-153AB1

② DIMENSIONS A AND B DO NOT INCLUDE MOLD PROTRUSIONS.

① CONTROLLING DIMENSIONS: MILLIMETERS.

**Land Pattern - TSSOP-14**

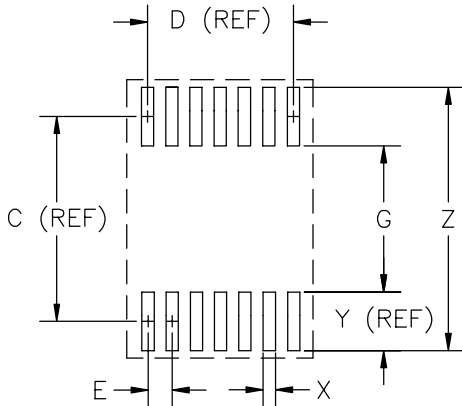

| DIM <sup>N</sup> | INCHES |      | MM    |       | NOTE |
|------------------|--------|------|-------|-------|------|
|                  | MIN    | MAX  | MIN   | MAX   |      |
| C                | —      | .218 | —     | 5.53  | REF  |
| D                | —      | .156 | —     | 3.96  | REF  |
| E                | —      | .026 | —     | 0.65  | BSC  |
| G                | .155   | —    | 3.947 | —     | —    |
| X                | —      | .013 | —     | 0.323 | REF  |
| Y                | —      | .062 | —     | 1.583 | —    |
| Z                | —      | .280 | —     | 7.113 | —    |

② GRID PLACEMENT COURTYARD IS 10 X 15 ELEMENTS (5mm X 7.5mm) IN ACCORDANCE WITH THE INTERNATIONAL GRID DETAILED IN THE IEC PUBLICATION 97.

① CONTROLLING DIMENSIONS: MILLIMETERS.

**Contact Information**

Semtech Corporation  
 Power Management Products Division  
 200 Flynn Road, Camarillo, CA 93012  
 Phone: (805)498-2111 FAX (805)498-3804