



Chipsmall Limited consists of a professional team with an average of over 10 year of expertise in the distribution of electronic components. Based in Hongkong, we have already established firm and mutual-benefit business relationships with customers from,Europe,America and south Asia,supplying obsolete and hard-to-find components to meet their specific needs.

With the principle of “Quality Parts,Customers Priority,Honest Operation,and Considerate Service”,our business mainly focus on the distribution of electronic components. Line cards we deal with include Microchip,ALPS,ROHM,Xilinx,Pulse,ON,Everlight and Freescale. Main products comprise IC,Modules,Potentiometer,IC Socket,Relay,Connector.Our parts cover such applications as commercial,industrial, and automotives areas.

We are looking forward to setting up business relationship with you and hope to provide you with the best service and solution. Let us make a better world for our industry!



Contact us

Tel: +86-755-8981 8866 Fax: +86-755-8427 6832

Email & Skype: info@chipsmall.com Web: www.chipsmall.com

Address: A1208, Overseas Decoration Building, #122 Zhenhua RD., Futian, Shenzhen, China



POWER MANAGEMENT

Description

The SC2603A is a versatile, low-cost, voltage-mode PWM controller designed for DC/DC power supply applications. A simple, fixed-voltage boost regulator can be implemented using the SC2603A with a minimum of external components. The small device footprint allows for compact circuit design.

SC2603A features include a temperature compensated voltage reference, triangle wave oscillator, current limit comparator, frequency shift over-current protection, and an internally compensated error amplifier. Pulse by pulse current limiting is implemented by sensing the differential voltage across an external resistor, or an appropriately sized PC board trace.

The SC2603A operates at a fixed frequency of 200kHz, providing an optimum compromise between efficiency, external component size, and cost.

Features

- ◆ Low cost / small size
- ◆ Input voltage range: 5V to 30V
- ◆ 200kHz switching frequency
- ◆ Up to 95% efficiency
- ◆ 1% reference voltage accuracy
- ◆ Typical 800mA PWM gate drive capability
- ◆ Internal compensation
- ◆ Over current protection
- ◆ SOT23-6 package is fully WEEE and RoHS compliant

Applications

- ◆ Portable Devices
- ◆ Flat Panel TV
- ◆ TV Set Top Box
- ◆ Auxiliary Supplies
- ◆ Peripheral Card Supplies
- ◆ Industrial Power Supply
- ◆ High Density DC/DC Conversion

Typical Application Circuit

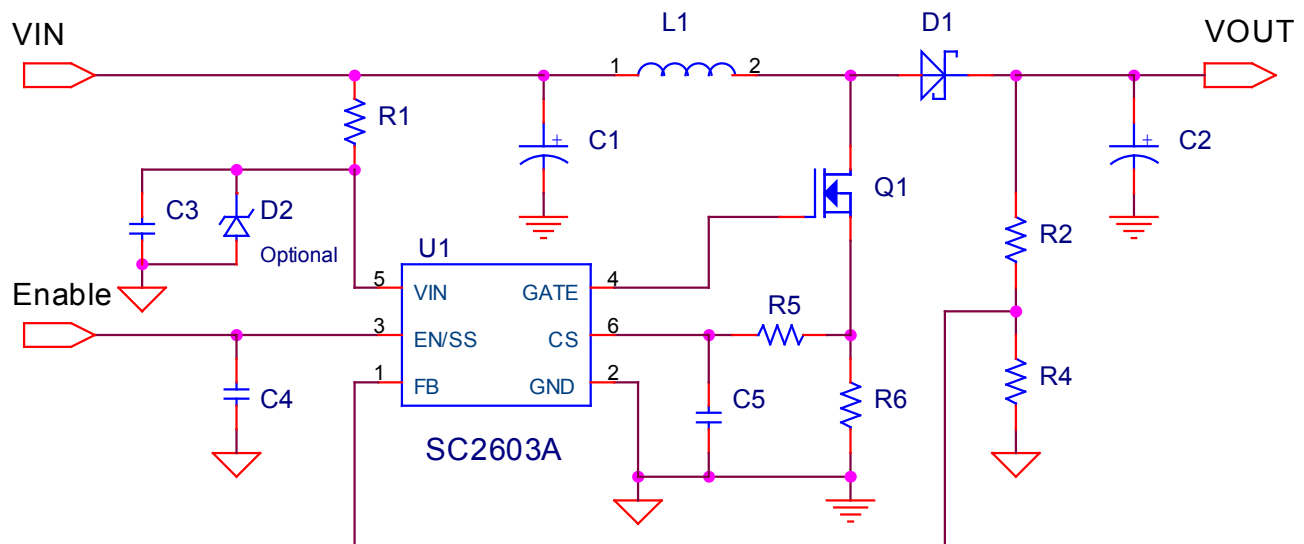

Figure 1: 12V to 25V/1A Boost Converter

POWER MANAGEMENT
Absolute Maximum Rating

Exceeding the specifications below may result in permanent damage to the device, or device malfunction. Operation outside of the parameters specified in the Electrical Characteristics section is not implied. Exposure to Absolute Maximum rated conditions for extended periods of time may affect device reliability.

Parameter	Symbol	Maximum	Units
Input Voltage	V_{IN} to GND	-0.3 to 20	V
GATE Pin Voltage	V_{GATE}	-0.3 to 20	V
EN/SS Pin Voltage	$V_{EN/SS}$	-0.3 to 7	V
FB Pin Voltage	V_{FB}	-0.3 to 7	V
Thermal Resistance Junction to Ambient ⁽¹⁾	θ_{JA}	165	°C/W
Thermal Resistance Junction to Case	θ_{JC}	102	°C/W
Maximum Junction Temperature	T_J	150	°C
Storage Temperature Range	T_{STG}	-45 to +150	°C
Lead Temperature (Soldering)10 sec	T_{LEAD}	300	°C
ESD Rating (Human Body Model)	ESD	2	kV

Note:

(1) Mounting pad has to be larger than one square inch on two sided printed circuit board with minimum 1 ounce copper

Electrical Characteristics

Unless specified: $V_{IN} = 12V$, $V_o = 25V$; $T_A = T_J = -40^\circ C$ to $125^\circ C$

Parameter	Symbols	Conditions	Min	Typ	Max	Units
General						
V_{IN} Supply Voltage	V_{IN}		4.5		16	V
V_{IN} UVLO Threshold	V_{UVLO}	V_{IN} ramping up		4.2	4.5	V
V_{IN} UVLO Hysteresis	V_{HYS}			400		mV
V_{IN} Supply Current		Current into V_{IN} pin during switching		6.0	9.0	mA
V_{IN} Shutdown Current		EN/SS=Low		5.0	6.0	mA
Error Amplifier						
Reference Voltage	V_{FB}		1.225	1.250	1.275	V
Feedback Bias Current	I_{FB}	$V_{IN} = 12V$, $V_{FB} = V_{EN/SS}$		2.0	8.0	μA
Error Amplifier Gain ⁽¹⁾				105		V/V
Oscillator						
Oscillator Frequency		$T_A = 25^\circ C$	190	200	210	kHz
Oscillator Frequency Shift		$V_{FB} < V_{REF} / 2$		50		kHz
Maximum Duty Cycle			90	95		%
Internal Ramp Peak	V_{R_PEAK}			1.4		V
Internal Ramp Valley	V_{R_VALLEY}			0.4		V

POWER MANAGEMENT

Electrical Characteristics (Cont.)

Parameter	Symbols	Conditions	Min	Typ	Max	Units
Regulation						
Load Regulation		$I_o = 0.1A$ to 1A		0.3	0.5	%
Line Regulation		$V_{IN} = 5V$ to 15V, $I_o = 0.1A$		0.5	1.0	%
PWM Gate Drive						
GATE Source Current		$V_{IN} = 12V$, $C_{GATE} = 10nF$	0.5	0.8	1.1	A
GATE Sink Current		$V_{IN} = 12V$, $C_{GATE} = 10nF$	0.5	0.8	1.1	A
Enable and Soft Start						
Soft Start Charge Current	I_{SS}			60		μA
Enable/Soft Start Threshold		Pull down below this level to disable PWM Switch gate	0.09	0.12		V
Switch Current Limit						
Current Limit Threshold		CS	65	73	80	mV

Note:

(1) Guaranteed by design

POWER MANAGEMENT

Pin Configurations

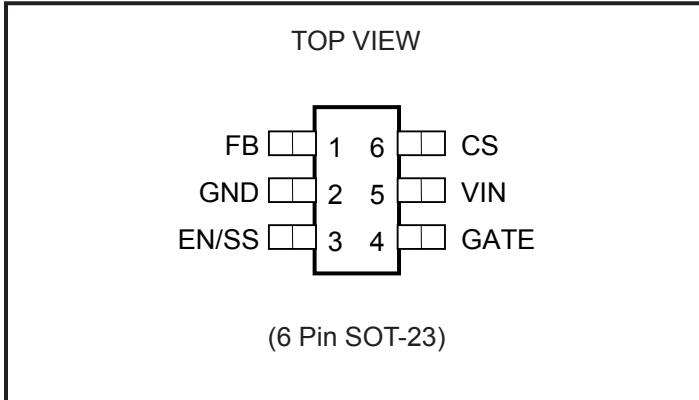

Ordering Information

Part Number	Package
SC2603ASKTRT ^(1,2)	SOT23-6
SC2603AEVB	Evaluation Board

Notes:

- (1) Only available in tape and reel packaging. A reel contains 3000 devices.
- (2) Lead free product. This product is fully WEEE and RoHS compliant.

Pin Descriptions

Pin	Pin Name	Pin Function
1	FB	Error amplifier inverted input
2	GND	Device ground
3	EN/SS	Enable / Soft Start Pin
4	GATE	PWM gate driver output
5	VIN	Device input voltage
6	CS	Current Sense input

Block Diagram

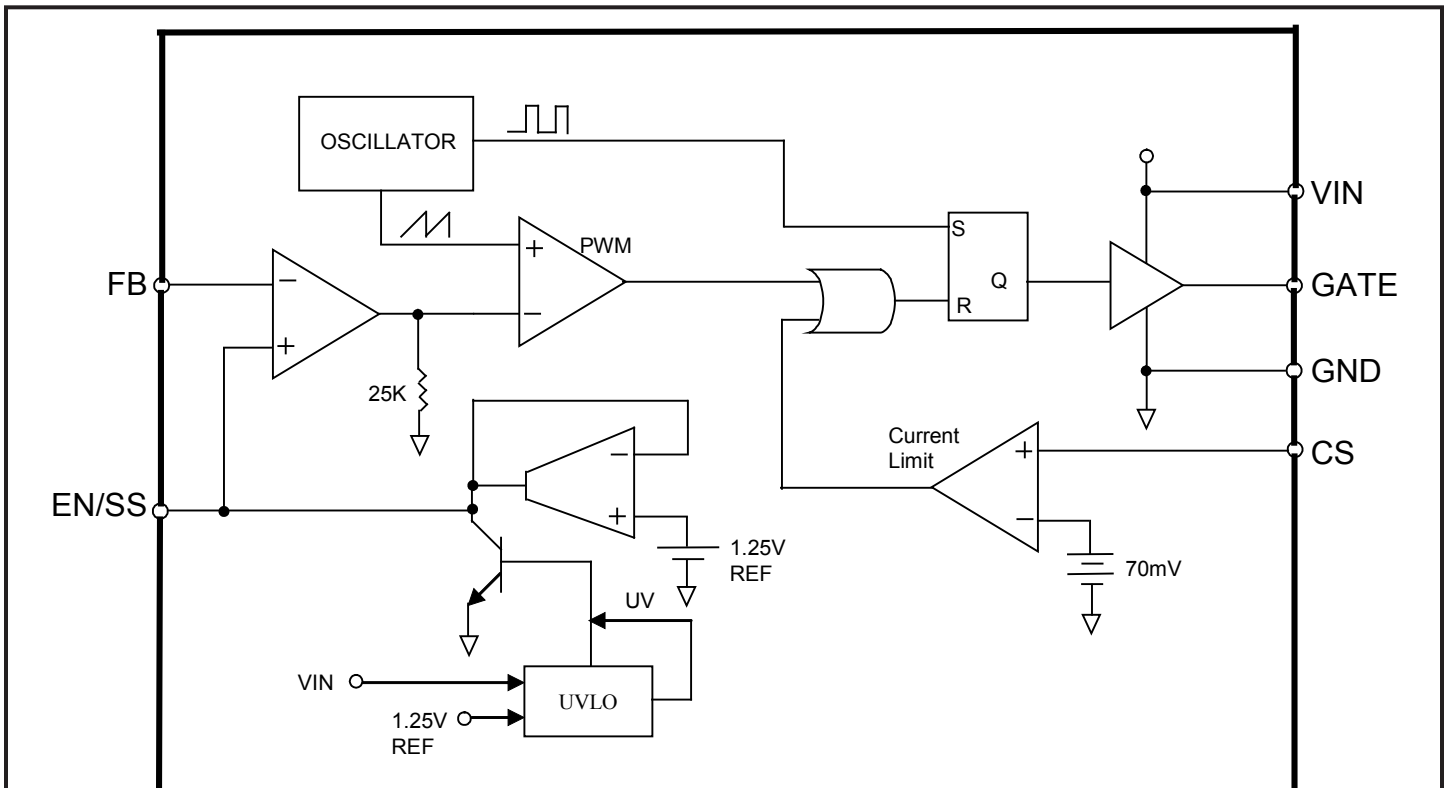

Figure 2: SC2603A Function Diagram

POWER MANAGEMENT
Applications Information
Theory of Operation

The SC2603A is a versatile, low-cost, voltage-mode PWM controller designed for DC/DC power supply applications. In normal condition, the SC2603A operates at a fixed 200kHz. One exception is that when the FB pin voltage drops to one half, the frequency will be shifted to one fourth of 200kHz.

SC2603A features include a temperature compensated voltage reference, triangle wave oscillator, current limit comparator, frequency shift over-current protection, and an internally compensated error amplifier. Pulse by pulse current limiting is implemented by sensing the differential voltage across an external resistor, or an appropriately sized PC board trace.

Setting the Output Voltage

As shown in Fig.1, an external resistive divider R2 and R4 with its center tap tied to the FB pin sets the output voltage.

$$R_2 = R_4 \left(\frac{V_{OUT}}{1.25V} - 1 \right)$$

Soft-Start

Soft-start prevents a DC-DC converter from drawing excessive current from the power source during start up. If the soft-start time is made sufficiently long, then the output will enter regulation without overshoot. An external capacitor is connected from the EN/SS pin to the ground. After the part's input voltage surpasses the UVLO, the EN/SS pin is allowed to charge its capacitor with 60µA. When 100mV is reached at the EN/SS pin, the internal comp node is at 0.4V. The SC2603A will start switching, and the converter output comes into regulation. Because the FB pin voltage follows EN/SS pin voltage, finally, the EN/SS pin voltage will be clamped at 1.25V same as the reference voltage.

Under Voltage Lockout

The under voltage lockout circuit of the SC2603A assures that the Gate output remains in the off state whenever the supply voltage drops below set parameters. Lockout occurs if VIN falls below 3.8V. Normal operation resumes once Vin rises above 4.2V.

Maximum Duty Cycle

The maximum duty cycle, D_{MAX} defines the upper limit of power conversion ratio

$$\frac{V_{OUT}}{V_{IN}} = \frac{1}{1 - D_{MAX}}$$

Clamping Diode D2 at VIN Pin

Since the VIN pin of the SC2603A is rated at 20V, when the supply voltage is higher than 16V, a Zener diode D2 is required to limit the SC2603A supply voltage, as shown in Fig.1. The clamping voltage of D2 has to be not higher than 15V.

Over Current Protection (OCP)

The over-current protection is implemented by a sensing resistor and an internal current-limit comparator with a threshold of 70mV. In each switching cycle, if the switching current through the sensing resistor causing the voltage at the CS pin reaches 70mV, the SC2603A will immediately turn the gate pulse off to limit the current through the power switch.

The figure below shows the current waveforms run into over-current protection. At t1, the input current I_{in} begins to increase as the load I_{out} builds up until it hits the OCP threshold at t2. At t2, V_{out} begins to drop as I_{out} starts increasing toward t3 while V_{in} and I_{in} remain the same. At t3, there two events are happening. 1) V_{out} is at half of its regulating voltage. At this point, the internal oscillator runs into frequency shift mode and shifts the frequency to one fourth of the operating frequency. 2) The diode starts conducting current without limit causing V_{in} to fall due to supply current limit. Finally, V_{in} and V_{out} both drops to zero and I_{in} becomes the input supply current limit.

A RC filter at the CS pin is necessary to filter out noise to ensure accurate sensing.

The value of the sensing resistor can be calculated by the following equation:

$$R_s = 70mV / I_{peak}$$

POWER MANAGEMENT

Applications Information (Cont.)

where I_{peak} is the input peak current through the power MOSFET.

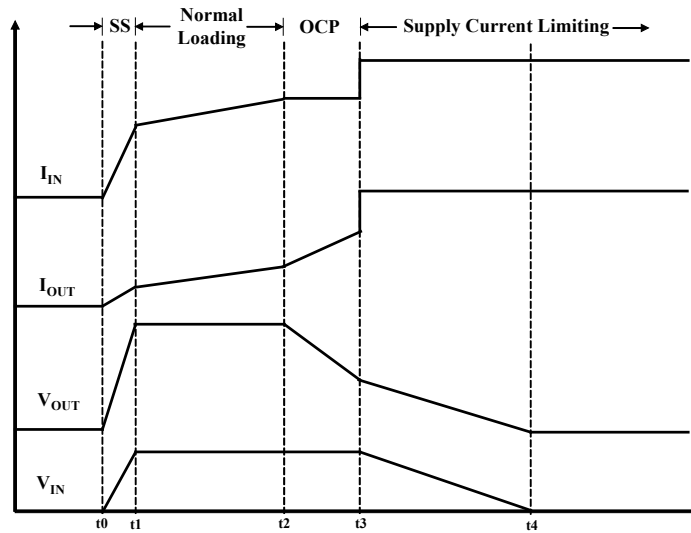

Figure 3. Current Waveforms

Layout Guidelines

Careful attentions to layout requirements are necessary for successful implementation of the SC2603A PWM controller. High currents switching at 200kHz are present in the application and their effect on ground plane voltage differentials must be understood and minimized.

1) The high power parts of the circuit should be laid out first. A ground plane should be used. The number and position of ground plane interruptions should be such as to not unnecessarily compromise ground plane integrity. Isolated or semi-isolated areas of the ground plane may be deliberately introduced to constrain ground currents to particular areas, for example the input capacitor and bottom Schottky ground.

2) The loop formed by the output Capacitor(s) (C_{out}), the FET (Q1), the current sensing resistor, and the Schottky (D1) must be kept as small as possible, as shown on the layout diagram in Fig.4. This loop contains all the high current, fast transition switching. Connections should be as wide and as short as possible to minimize loop inductance. Minimizing this loop area will reduce EMI, lower ground injection currents, resulting in electrically “cleaner” grounds for the rest of the system and minimize source ringing, resulting

in more reliable gate switching signals.

3) The connection between the junction of Q1, D1 and the output capacitor should be a wide trace or copper region. It should be as short as practical. Since this connection has fast voltage transitions, keeping this connection short will minimize EMI.

4) The Output Capacitor(s) (C_{out}) should be located as close to the load as possible, fast transient load currents are supplied by C_{out} only, and connections between C_{out} and the load must be short, wide copper areas to minimize inductance and resistance.

5) The SC2603A is best placed over an isolated ground plane area. The soft-start capacitor, the V_{in} decoupling capacitor, and the current sensing filter capacitor should also connected to this ground pad area. This isolated ground area should be connected to the main ground by a trace that runs from the GND pin to the ground side of the output capacitor. If this is not possible, the GND pin may be connected to the ground path between the Output Capacitor and the C_{in} , Q1, D1 loop. Under no circumstances should GND be returned to a ground inside the C_{in} , Q1, D1 loop.

6) Input voltage of the SC2603A should be supplied from the power rail through a 2.2~10Ω resistor, the V_{in} pin should be decoupled directly to GND by a 0.1μF~1μF ceramic capacitor, trace lengths should be as short as possible.

7) An RC low pass filter is required to filter out leading edge current spikes on the current sensing resistor. The filter capacitor needs to be very close to the CS and GND to reduce noise pickup.

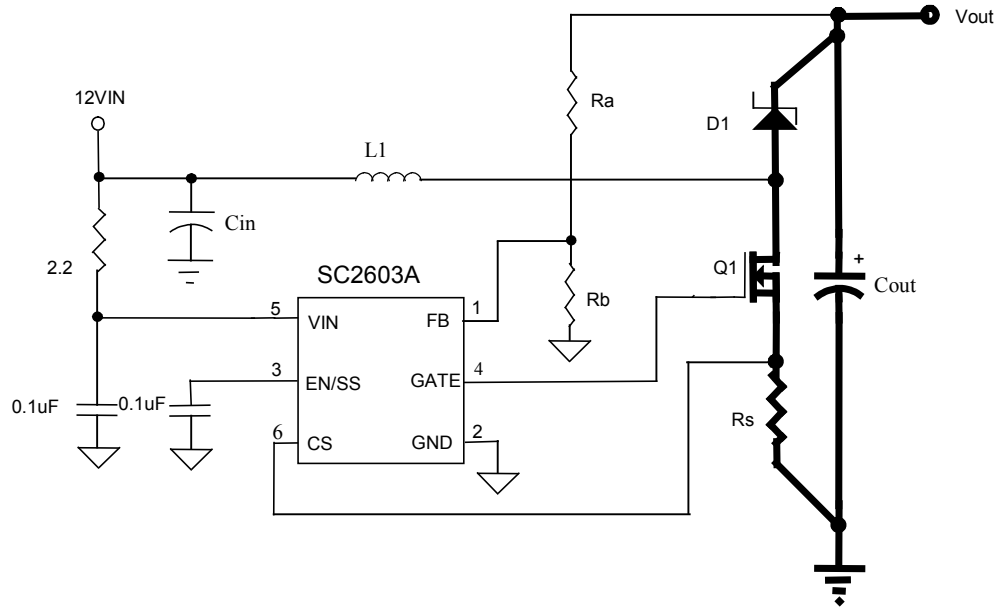
POWER MANAGEMENT
Applications Information (Cont.)
Layout diagram for the SC2603A

Note: Heavy lines indicate the critical loop carrying high pulsating current.
The inductance of the loop needs to be minimized.

Figure 4: SC2603A Layout Diagram

POWER MANAGEMENT

Applications Information (Cont.)

Typical application schematic with 12V input and 24V/1A output

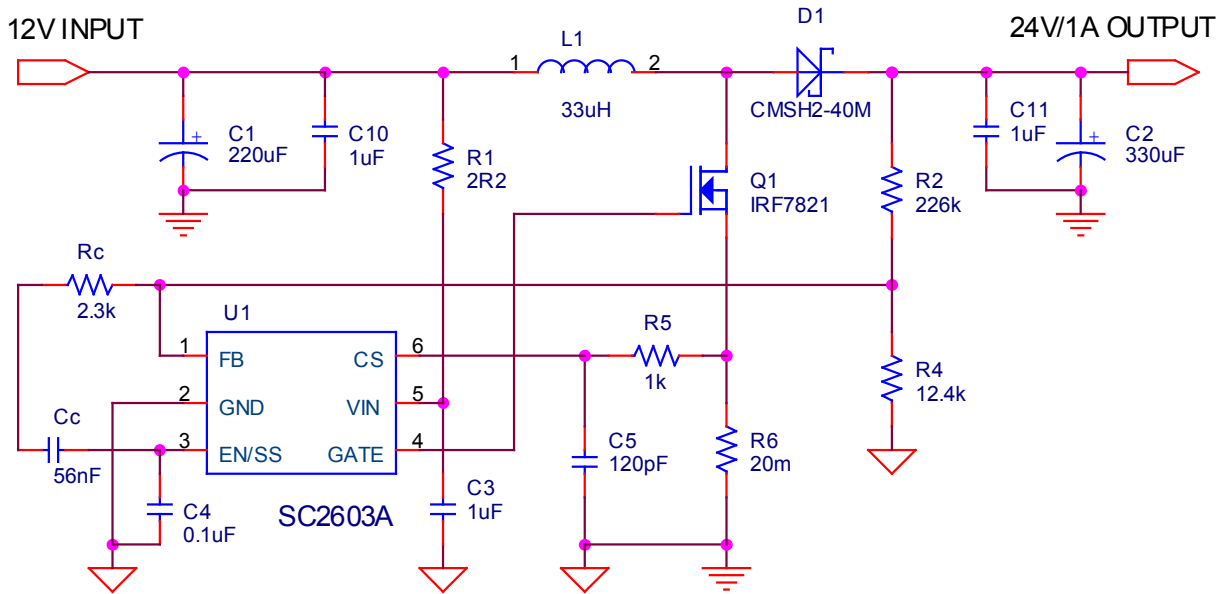

Bill of materials

Item	Quantity	Reference	Part	Vendor
1	1	C1	220uF/16V	Panasonic
2	1	C2	330uF/35V	Nichicon, VR
3	2	C3,C10	1uF/16V	Vishay
4	1	C4	0.1uF	Vishay
5	1	C5	120pF	Vishay
6	1	C11	1uF/50V	Vishay
7	1	Cc	56nF	Vishay
8	1	D1	CMSH2-40M	Central Semi
9	1	L1	33uH/5.1A (HC8-330)	Coiltronics
10	1	Q1	IRF7821	IR
11	1	R1	2R2	Vishay
12	1	R2	226k	Vishay
13	1	R4	12.4k	Vishay
14	1	R5	1k	Vishay
15	1	R6	20m	Vishay
16	1	Rc	2.3k	Vishay
17	1	U1	SC2603A	Semtech

POWER MANAGEMENT

Outline Drawing - SOT23-6

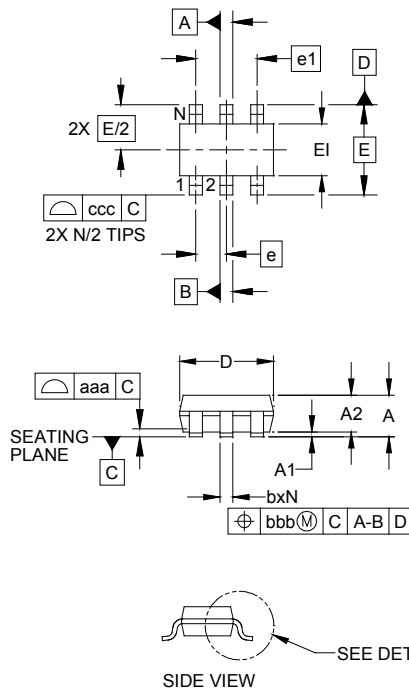

DIM	DIMENSIONS					
	INCHES			MILLIMETERS		
	MIN	NOM	MAX	MIN	NOM	MAX
A	.035	-	.057	0.90	-	1.45
A1	.000	-	.006	0.00	-	0.15
A2	.035	.045	.051	.90	1.15	1.30
b	.010	-	.020	0.25	-	0.50
c	.003	-	.009	0.08	-	0.22
D	.110	.114	.122	2.80	2.90	3.10
E1	.060	.063	.069	1.50	1.60	1.75
E	.110 BSC			2.80 BSC		
e	.037 BSC			0.95 BSC		
e1	.075 BSC			1.90 BSC		
L	.012	.018	.024	0.30	0.45	0.60
L1	(.024)			(0.60)		
N	6			6		
θ1	0°	-	10°	0°	-	10°
aaa	.004			0.10		
bbb	.008			0.20		
ccc	.008			0.20		

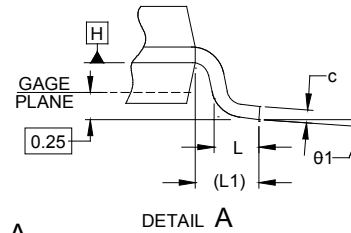

- NOTES:
1. CONTROLLING DIMENSIONS ARE IN MILLIMETERS (ANGLES IN DEGREES).
 2. DATUMS **-A-** AND **-B-** TO BE DETERMINED AT DATUM PLANE **-H-**
 3. DIMENSIONS "E1" AND "D" DO NOT INCLUDE MOLD FLASH, PROTRUSIONS OR GATE BURRS.

Land Pattern - SOT23-6

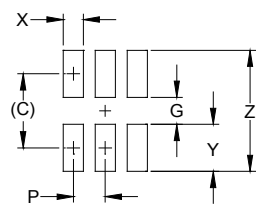

DIM	DIMENSIONS	
	INCHES	MILLIMETERS
C	(.098)	(2.50)
G	.055	1.40
P	.037	0.95
X	.024	0.60
Y	.043	1.10
Z	.141	3.60

- NOTES:
1. THIS LAND PATTERN IS FOR REFERENCE PURPOSES ONLY. CONSULT YOUR MANUFACTURING GROUP TO ENSURE YOUR COMPANY'S MANUFACTURING GUIDELINES ARE MET.

Contact Information

Semtech Corporation
 Power Management Products Division
 200 Flynn Road, Camarillo, CA 93012
 Phone: (805)498-2111 FAX (805)498-3804